

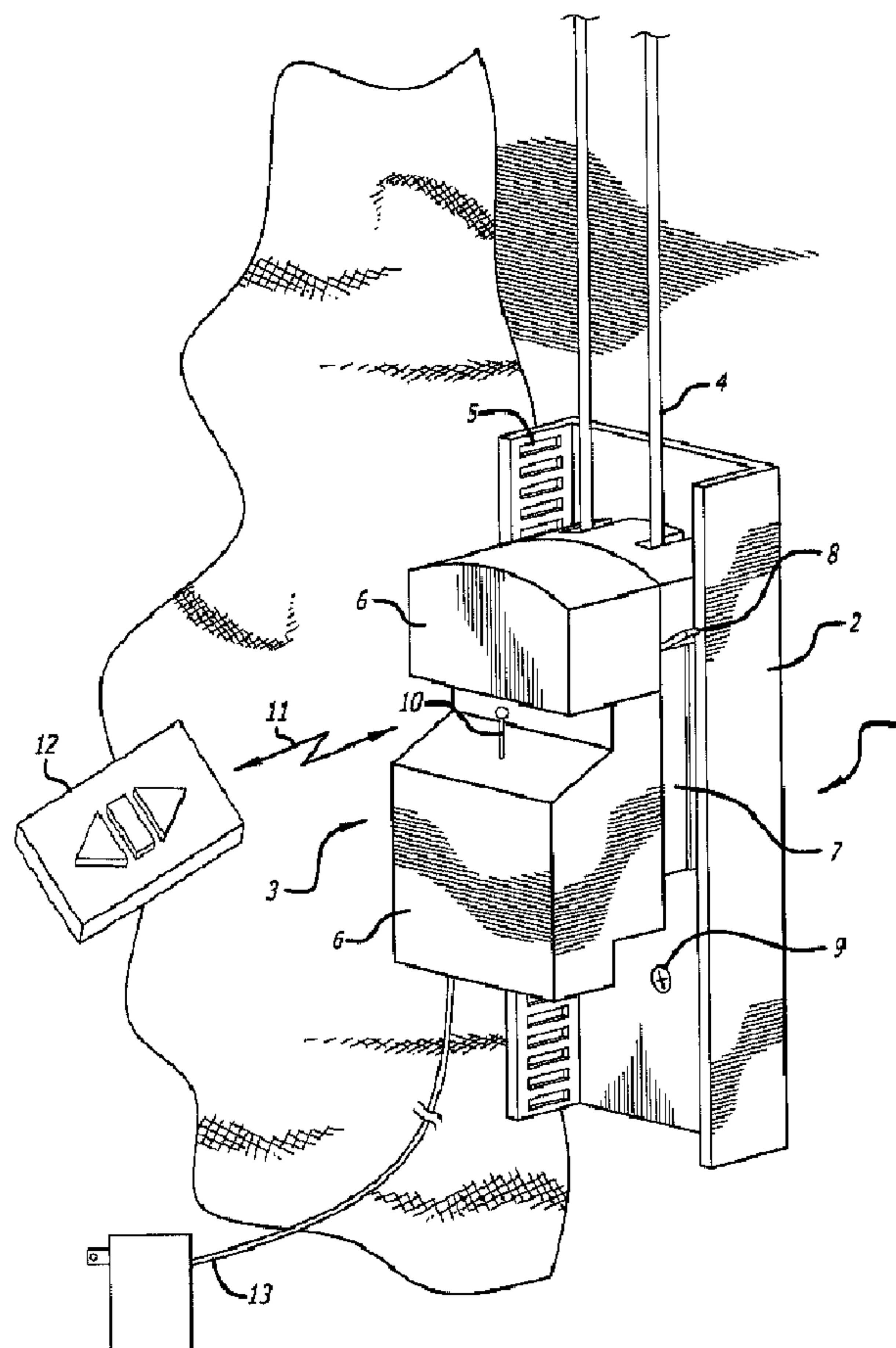

(22) Date de dépôt/Filing Date: 2013/06/25
(41) Mise à la disp. pub./Open to Public Insp.: 2014/01/03
(30) Priorité/Priority: 2012/07/03 (IR13915014000302684)

(51) Cl.Int./Int.Cl. *A47H 5/02* (2006.01)
(71) Demandeur/Applicant:
RASTEGAR, HOSSEIN, US
(72) Inventeur/Inventor:
RASTEGAR, HOSSEIN, US
(74) Agent: HEENAN BLAIKIE LLP

(54) Titre : DISPOSITIF DE DEPLACEMENT DE RIDEAU ELECTRONIQUE
(54) Title: ELECTRONIC CURTAIN MOVING DEVICE



(57) Abrégé/Abstract:

Provided is an electronic curtain moving device. Thus device can comprise: a pulley operably connected to a motor, the pulley having a groove through which a cord of a curtain travels, wherein the pulley can move in clockwise and counter-clockwise



(57) **Abrégé(suite)/Abstract(continued):**

directions; a head capable of movement from a first and a second position; Wherein movement of the pulley in the clockwise direction makes the head move to the first position and make contact with the cord, and movement of the pulley in the counter-clockwise direction makes the head move to the second position and make contact with the cord at a different location than contact at the first position

Abstract

Provided is an electronic curtain moving device. Thus device can comprise: a pulley operably connected to a motor, the pulley having a groove through which a cord of a curtain travels, wherein the pulley can move in clockwise and counter-clockwise directions; a head capable of movement from a first and a second position; Wherein movement of the pulley in the clockwise direction makes the head move to the first position and make contact with the cord, and movement of the pulley in the counter-clockwise direction makes the head move to the second position and make contact with the cord at a different location than contact at the first position

ELECTRONIC CURTAIN MOVING DEVICE

Cross-Reference

[001] The present application claims the benefit of Iranian Patent Application No. 13915014000302684 filed on July 3, 2012, and issued on August 22, 2012, under Registration No. 76439, whose content is incorporated herein by reference in its entirety.

Background Section of the Invention

[002] There is generally a need for moving curtains automatically without manual effort. Curtains for example can be heavy, inaccessible and also can be inconvenient to open and close manually.

[003] The art proposes several devices to automatically move curtains. These devices have multiple drawbacks.

[004] First, most of these devices are expensive and need special rods and meant to be installed by a professional with special tools. They also need costly periodical service and maintenance. Second, most of these devices rely on physical means (such as limit switches) to limit the range of travel for the device. A user has to constantly adjust these physical means since limit switches will not be in the correct position in order to operate correctly after a while. In case of obstacle in the traveling course of the curtain rod, these devices cannot stop operation, which will damage curtain, curtain rod and the device itself. Third, the art lacks a device that can adjust itself automatically overtime as the cord of the curtain loses its length integrity and stretches with each day passing, resulting in loss of tight grip needed between cord and pulley for consistence operation.

[005] Fourth, the devices of the art can be noisy, lack intelligence, rely on materials for the cord of a curtain that are expensive, and prone to break, and be difficult to install and operate.

[006] There is a need in the art for a device for electronically and intelligently moving a curtain without the drawbacks present in the art.

Summary Section of the Invention

[007] In one embodiment, provided is an electronic device for movement of a curtain comprising: a. a pulley operably connected to a motor, the pulley having a groove through which a cord of a curtain travels, wherein the pulley can move in clockwise and counter-

clockwise directions; b. a head capable of movement from a first and a second position; wherein movement of the pulley in the clockwise direction makes the head move to the first position and make contact with the cord, and movement of the pulley in the counter-clockwise direction makes the head move to the second position and make contact with the cord at a different location than contacting at the first position. The head is operably connected to a motor separate from the motor of the pulley. The pulley has a V shaped groove for placement of the cord and the groove of the pulley has a textured plastic coating that creates a non-uniform surface. The weight of the device is supported by the cord, allowing the device to move downward in the event that the cord stretches overtime, providing a tight connection between the pulley and the cord all the time. The device is placed in a rail system attached to the wall that limits the movement of the device in lateral and upward direction. The device comprises first and second sections which pivotally attached to each other, wherein the first section pivots clockwise and counter-clockwise in relation to the second section in direction of movement of the pulley to allow for contacting between the head and the cord. The device determines the position of beginning and ending of the curtain rod based on the amperage that the main motor which is attached to the pulley uses. The device can terminate operation of pulling the cord when the main motor amperage exceeds a predetermined level. The device upon termination of the operation can allow free movement of the main motor which is attached to the pulley, this free movement resulting in release of tension existing in the cord. The predetermined level of amperage, which is used by the main motor, indicates full open or full closed positions of the curtain. This predetermined level of amperage can also indicate an obstacle in the traveling course of the curtain. The device can measure amperage of the main motor a plurality of times every second. The device can self-program its action based on prior use. The device can open or close the curtain randomly to provide an impression that a person is opening or closing the curtain. The device can close the curtain in direct sun light. The device can be remotely controlled. The device can automatically pull the cord to fully open or fully close the curtain based on pre-set time of day.

[008] In one embodiment, provided is a method for operating or closing a curtain comprising using the device as described above.

[009] In one embodiment, provided is an electronic device for movement of a curtain comprising a pulley operably connected to a motor, the pulley having a groove through which a

cord of a curtain travels, wherein the pulley can move in clockwise and counter-clockwise directions; wherein weight of the device rests on the cord.

[0010] In one embodiment, provided is an electronic and mechanical device for movement of a curtain comprising: a. An operation compartment comprising: i. A pulley operably connected to a first motor, the pulley having a groove through which a cord of a curtain travels, wherein the pulley can move in clockwise and counter-clockwise directions; ii. A head operably connected to a second motor capable of movement from a first and a second position laterally; wherein movement of the pulley in the clockwise direction makes the head move to the first position and make contact with the cord, and movement of the pulley in the counter-clockwise direction makes the head move to the second position and make contact with the cord at a different location than contacting at the first position; b. A control compartment comprising mechanical and electronic hardware for making the head and the pulley work; c. A rail system, in which the operation compartment is placed, this rail system limits lateral or upward movement of the operation compartment; wherein the weight of the device rests on the cord; wherein the first motor has a shaft that creates a pivot point, allowing the control compartment to pivot in relation to the operation compartment, direction of the pivot determined by direction of rotation of the pulley.

Brief Description of the Figures

[0011] Figure 1A is an illustration of the electronic curtain moving device in a rail system.

[0012] Figure 1B is an illustration of the electronic curtain moving device in a pivoted position.

[0013] Figure 2 is an illustration of the electronic curtain moving device outside of the rail system, with the operation compartment illustrated in detail.

[0014] Figure 3 is a side view of the electronic curtain moving device.

[0015] Figure 4 is an illustration of the electronic curtain moving device outside of the rail system, with the operation compartment illustrated in detail.

[0016] Figure 5 is an illustration of the electronic curtain moving device inside of the rail system, with the operation compartment illustrated in detail.

[0017] Figure 6 is an illustration of the electronic curtain moving device inside of the rail system, with the pulley moving in counter-clockwise direction.

[0018] Figure 7 is an illustration of the electronic curtain moving device inside of the rail system, with the pulley moving in a clockwise direction.

[0019] Figure 8 is an illustration of the electronic map of the electronic curtain moving device.

[0020] Figure 9 is a flow chart illustrating a program for controlling the movement of curtain and acting based on amperage of the motor.

[0021] Figure 10 is a flow chart illustrating a program for randomly opening and closing a curtain.

[0022] Figure 11 is a flow chart illustrating a program for simulating a pattern of behavior.

Detailed Description of the Invention

[0023] The present invention provides an electronic curtain moving device (ECMD 1) which is cost effective to manufacture, can be used with any cord driven curtain rod , and can be installed by anyone without any special skills and literally is a DIY(do it yourself) device. The ECMD 1 automatically adjusts itself to the length of the curtain rod and intelligently recognizes the start position and end position of the curtain rod each time it operates, making the ECMD 1 effective and easy to use and requiring no maintenance at all. The device also can be installed in less than five minutes without any special tools.

[0024] ECMD 1 can be installed on windows of various lengths: ECMD 1 can be installed on any window of any length and is capable of moving home, hospital, hotel and office curtains of any weight and length.

[0025] ECMD 1 is capable of this identification for curtains of various lengths, and can "open" or "shut" or "stop" a curtain at any point along the curtain rod. ECMD 1 can work with any cord driven curtain rods. There is no need to replace or obtain a special curtain rod.

[0026] ECMD 1 is made in one embodiment to rest on the cord 4 itself, and as cord 4 stretches, ECMD 1 maintains the necessary tension. ECMD 1 does not require any type of limit switches (other physical means to keep the device functional), which are installed on the curtain rod for recognizing the start position and end position of the curtain rod. In one embodiment, ECMD 1 is made with head 15 that has its own motor and transmission, and touches cord 4 on either side of the head 15 depending on the direction of the movement of the pulley 14.

[0027] ECMD 1 can control home, hospital, office and hotel (or other places where the need exists) curtain rods of any size and weight with any working systems (leftward opening,

rightward opening, center opening) There is no need for the presence of the user in the place and his/her manual labor for controlling curtain rods. Rather by a momentary pressing of the triple commands switches on the wall or by issuing commands through the remote control unit 12 or by control systems command in the absence of the user, curtains are controlled by ECMD 1 automatically and intelligently, opening or shutting or stopping at their course, where the user intends.

[0028] Figure 1A illustrates the ECMD 1. The operation compartment 7 can sit in a rail system 2. The rail system 2 is attached to the wall with screws 9. The rail system 2 has a plurality of holes 5 for the blades 8 to move in and out. The device which is put in the rail system 2 is a one piece device that has two main compartments. Control compartment 6 and operation compartment 7 are pivotally attached to the each other. Control compartment 6 contains all the components that do not physically contact the cord 4, including head motor 16 and main motor 17, transmission 18 and electronic equipment 19. Cord 4 can be made of any material that can wrap around the pulley 14 and be moved by the pulley 14. Metallic, natural and synthetic non-metallic material can be used. In one embodiment, a non-metallic synthetic material such as polyester is used. The material has flexibility and be somewhat stretchable without tearing. This material is suitable for holding the weight of ECMD 1. Control Compartment 6 has an antenna 10 or other receivers for receiving information from remote control 12. Control Compartment 6 has an electronic connection 13 to a source of power. Operation compartment 7 includes blades 8.

[0029] Figure 1B is the same figure as figure 1A except that the device is in use and control compartment 6 has pivoted 30 degrees to the right in relation to operation compartment 7. If the device is used to pull the cord 4 in the opposite direction, the device would also pivot 30 degrees in the opposite direction. When the V shaped pulley 14 of the main motor 17 starts to pull, the force transfer thread resists against the pull generated at the beginning of the movement, resulting in pivoting of the device. The device can be designed with various degrees of pivoting, such as about 10 to about 40 degrees.

[0030] Figure 2 illustrates the details of the operation compartment 7. The pulley 14 and the head 15 are inside the operation compartment 7. Head 15 prevents the cord 4 from coiling around the V shaped pulley 14 which would have locked the main motor 17. The head's 15 function is to swiftly take out that part of the force transfer cord 4 released from the V shaped

pulley 14 from inside the operation compartment 7 so to prevent that part of the slackened cord 4 released by the V shaped pulley 14 from recoiling around that pulley 14 due to friction with the inner wall of said pulley 14, and impeding its movement and locking it. Cord 4 wraps around groove 49 of pulley 14. The cord 4 passes on both sides of head 15. Blades 8 are attached to the operation compartment 7. Control compartment 6 is pivotally attached to the operation compartment 7. Operation compartment 7 is placed in the rail system 2, which is attached to the wall through screws 9. The interaction of blades 8 and holes 5 limit upward movement (Upward Auto Lock System) of the operation compartment 7. To remove the operation compartment 7 from the rail system 2, blades 8 can be unlocked. Rail system 2 also limits lateral movement of the operation compartment 7.

[0031] Figure 3 illustrates a side view of the device. The control compartment 6 houses the head motor 16 (which includes a transmission that is not illustrated). The control compartment 6 also houses the electronic control unit 19, and antenna 10 capable of receiving electronic communication 11 from the remote control 12. The control compartment 6 houses the transmission 18 that operably connects the pulley 14 with the main motor 17. The main motor 17 is shown in figure 2 is extending away from the control compartment 6 and attached to the transmission 18 which is located in the control compartment 6.

[0032] Operation compartment 7 is shown with pulley 14 and head 15. Operation compartment 7 is placed inside the rail system 2. The pulley 14 has a V shaped groove 49 and coating 20 for increasing friction on the pulley 14. The coating 20 is made of an Ultra-high-molecular-weight polyethylene (UHMWPE, UHMW). The coating 20 provides a durable abrasion resistant, textured and non-skid finish. The cord 4 wraps around pulley 14. There are two connections between the operation compartment 7 and control compartment 6. One connection is shaft 21, which connects transmission 18 and pulley 14. Shaft 21 is the point where the device pivots. The shaft 21 has three functions: a) Connecting the control compartment 6 to the operation compartment 7; b) Transferring force from the transmission 18 in the control compartment 6 to the V shaped pulley 14, which is installed in the operation compartment 7; c) Rotating the control compartment 6 around (its own axis) shaft 21, 30 degrees left and right in relation to the operation compartment 7 at the start of the motion of the main motor 17 (due to the curtain rod movement control thread resisting at the beginning of the pull).

[0033] The second connection is shaft 50, connecting head motor 16 to head 15. An opening (cut in the housing) 51 in the operation compartment 7 allows shaft 50 to move laterally, to allow for pivoting of the control compartment 6 in relation to the operation compartment 7.

[0034] Figure 4 illustrates operation compartment 7 before it is placed in the rail system 2. Cord 4 has wrapped around pulley 14, and travels on each side of head 15. Blades 8 limit upward movement of the operation compartment 7 by fitting into the holes 5. Rail system 2 is attached to the wall through screws 9.

[0035] Figure 5 is the same illustration as figure 4 except that the operation compartment 7 is now placed in the rail system 2. Blades 8 interact with the rail system 2, and allow only for downward movement of the operation compartment 7. The walls of the rail system 2 also limit lateral movement of the operation compartment 7. Operation compartment 7 which is put in the rail system 2, is now supported by cord 4, otherwise ECMD 1 would fall down.

[0036] Figure 6 is the same illustration as figure 5 except that the ECMD 1 is now operating. The pulley 14 is pulling cord 4 in counter-clockwise fashion. The force generated by the pulley 14 at the start point of operation has made the head 15 move to the right side and contact cord 4. Figure 7 is the same illustration as figure 6 except that the pulley 14 is travelling in clockwise fashion, and has made the head 15 move to the left side. Control compartment 6 (not shown in these figures) would pivot left and right in each of these figures.

[0037] Figure 8 illustrates an electronic map of ECMD 1. Various components are in electronic communication with CPU 31. A user may interact with the ECMD 1 with various remote controls 19. These controls can include wired controls 26 such as a personal computer 27 (P.C.). Wired controls 26 are ideal for places with a plurality of rooms, such as hotels. There can also be wireless controls 11, wherein a remote control 12 or a wall mounted timer 25 can be used. The ECMD 1 includes a memory 29 (such as a flash memory), power source 13, power control 46, command switches 47, head motor 16 and main motor 17, voice command 20, present simulation 30, light sensor 48, and display 22.

[0038] Electronic components can include a) An amperage electronic control system for automatically and intelligently stopping the curtain at the start position or end position, b) A remote control system which is equipped with rolling code and also three different radio channels for issuing the triple commands: open, shut, and stop.. This remote control system is capable of modulating commands on "new passwords" in each transmission by using its rolling

code system, c) An "RS-485" Telecommunication System for establishing a united network of devices which could also be controlled by a P.C. (personal computer). This system is applicable in hotels, hospitals, residential complexes or offices, d) A triple-command of "open", "shut" and "stop" system on the Control compartment 6, e) An input portal for connecting to the intelligent control systems such as various sensors and receiving their commands, f) An input portal for connecting to the cable of triple-command wall switches, g) An input portal for connecting to the telecommunication system "RS-485", h) An eightfold deep switch for giving address to each ECMD 1 in binary codes and exclusive manner, i) An input portal for 24V, 3 Ampere feed , j) A triple power control key for exerting three power statuses of the main motor 17 for light, medium and heavy weight curtains, k) A key for determining motors' rotation for leading the correct direction of rotation when the loop of the curtain rod movement control thread is being installed inside the V shaped pulley's groove 49, l) A reset key for resetting all electronic systems of the ECMD 1, m) A "learning" key of the remote control for the remote module, n) An activation key for the intelligent learning system; comprehending and exerting of the user's action on the control compartment 6.

[0039] Figure 9 is a flow chart illustrating how the device is programmed to function. When the amperage hits a predetermined level 34, the main motor 17 and head motor 16 are stopped to put the curtain in a proper position (fully opened or fully closed). The motor amperage measurement section 32 that is in the electronic communication with the CPU 31 constantly measures motor amperage 33 and compares the measured amperage to a predetermined level 34. If the measured amperage is less than the predetermined level 35, the operation 37 (pulling of curtain cord) is continued. If the measured amperage exceeds to predetermined level 36, either the ending or beginning points of the curtain rod or an obstacle 38, the operation of the main motor 17 and head motor 16 is terminated 39 to put the curtain in fully opened position or fully closed position or to stop the curtain immediately to prevent the main motor 17 and head motor 16 and also curtain and curtain rod from damage in case of obstacle 38. In one embodiment, when the amperage of main motor 17 increases and passes from 900 M AMP, the amperage electronic control system comes into play and reduces the input voltage to the main motor 17 and head motor 16 from 24V to 0V. This operation can take place in less than one second so that as soon as the curtain reaches the beginning position or end position of the curtain rod, the related system

turns the head motor 16 and main motor 17 off, and stop the curtain. The amperage electronic control system of CPU 31 can monitor the motor's amperage, 10 times per second.

[0040] Depending on the amperage of main motor 17 uses, ECMD 1 determines whether an the curtain has hit an obstacle or is at an end or start position. . When end of the curtain rod is obtained, ECMD 1 resets its internal memory (if there is an inconsistency) and marks the position as the end of the curtain rod.

[0041] Figure 10 illustrates programming the ECMD1 to randomly open and close 42 during daytime 40. The commands are randomly generated 41 by CPU31. This computer implemented program simulates that a person is home and therefore keeps away burglars. ECMD 1 can be also connected to the home alarm system, so that when the alarm is set and the user leaves home, this system is automatically implemented.

[0042] Figure 11 illustrates programming the ECMD 1 to simulate a user's pattern. The ECMD 1 first determines a pattern of behavior 43. For example, the pattern of behavior is the time a user opens or closes a curtain. The ECMD 1 then simulates the pattern of behavior 44. The ECMD 1 is equipped with a new electronic system called "The intelligent system of learning and comprehending user behavior". When the user activates this system, it monitors the user's behavior in controlling the curtain rod during the first 24 hours and learns this behavior. It observes all commands issued by the user to the ECMD 1 and their times, preserving them in its memory. At the end of the first 24 hours, the system begins to control the curtain rod based on the information it has received from the user during the first 24 hours, so that it issues said commands at their specific times to the electronic control system of the ECMD 1. For instance, if the user has issued the "open" command at 7 AM during the first 24 hours, each day at the same time the "open" command will be automatically issued to the electronic control system of the ECMD 1 so that the curtain will be opened at that specific time automatically. This system is capable of receiving and preserving one hundred "open", "shut" and "stop" commands during the first 24 hours and in the following days, it will issue the same commands at their specific time to the ECMD 1. In case the user does not need this system to control the curtain, it can be deactivated by the related button on the control compartment 6.

[0043] Also provided is a method of using the device described herein.

What is claimed is:

1. An electronic device for movement of a curtain comprising:
 - a. a pulley operably connected to a motor, the pulley having a groove through which a cord of a curtain travels, wherein the pulley can move in clockwise and counter-clockwise directions;
 - b. a head capable of movement from a first and a second position; Wherein movement of the pulley in the clockwise direction makes the head move to the first position and make contact with the cord, and movement of the pulley in the counter-clockwise direction makes the head move to the second position and make contact with the cord at a different location than contact at the first position.
2. The device of claim 1, wherein the head is operably connected to a motor separate from the motor of the pulley.
3. The device of claim 1 or 2, wherein the pulley has a V shaped groove for placement of the cord and the groove of the pulley has a textured plastic coating that creates a non-uniform surface.
4. The device of claim 1, 2, or 3, wherein weight of the device is supported by the cord, allowing the device to move downward in the event that the cord stretches overtime, providing a tight connection between the pulley and the cord all the time.
5. The device of claim 4, wherein device is placed in a rail system attached to the wall that limits the movement of the device in lateral and upward direction.
6. The device of claim 1, 2, 3, 4, or 5, wherein device comprises a first and second section pivotally attached to each other, wherein the first section pivots clockwise and counterclockwise in direction of movement of the pulley to allow for contact between the head and the cord.
7. The device of claim 1, 2, 3, 4, 5, or 6, wherein the device determines the position of beginning and ending of the curtain rod based on amperage that the pulley motor uses.
8. The device of claim 7, wherein the device terminates operation of pulling the cord when the motor amperage exceeds a predetermined level.
9. The device of claim 8, wherein the device upon termination of the operation allows free movement of the pulley, the free movement resulting in release of tension existing in the cord.
10. The device of claim 8 or 9, wherein the predetermined level indicates a full open or full closed position.

11. The device of claim 8, 9, or 10, wherein the predetermined level indicates an obstacle.
12. The device of claim 1, 2, 3, 4, 5, 6, 7, 8, 9, 10, or 11, wherein the device measures amperage of the motor a plurality of times every second.
13. The device of claim 1, 2, 3, 4, 5, 6, 7, 8, 9, 10, 11, or 12, wherein the device self-programs its action based on prior use.
14. The device of claim 1, 2, 3, 4, 5, 6, 7, 8, 9, 10, 11, 12, or 13, wherein the device can open and close the curtain randomly to provide an impression that a person is opening and closing the curtain.
15. The device of claim 1, 2, 3, 4, 5, 6, 7, 8, 9, 10, 11, 12, 13, or 14, wherein the device can close the curtain in direct sun light.
16. The device of claim 1, 2, 3, 4, 5, 6, 7, 8, 9, 10, 11, 12, 13, 14, or 15, wherein the device can be remotely controlled.
17. The device of claim 1, 2, 3, 4, 5, 6, 7, 8, 9, 10, 11, 12, 13, 14, 15, or 16, wherein the device automatically pulls the cord to fully open or fully close the curtain based on pre-set time of day.
18. An electronic device for movement of a curtain comprising a pulley operably connected to a motor, the pulley having a groove through which a cord of a curtain travels, wherein the pulley can move in clockwise and counter-clockwise directions; wherein weight of the device rests on the cord.
19. An electronic device for movement of a curtain comprising:
 - a) An operation compartment comprising
 - i) A pulley operably connected to a first motor, the pulley having a groove through which a cord of a curtain travels, wherein the pulley can move in clockwise and counter-clockwise directions;
 - ii) A head operably connected to a second motor capable of movement from a first and a second position; wherein movement of the pulley in the clockwise direction makes the head move to the first position and make contact with the cord, and movement of the pulley in the counter-clockwise direction makes the head move to the second position and make contact with the cord at a different location than contact at the first position;
 - b) A control compartment comprising mechanical and electronic hardware for making the head and the pulley work;

wherein the operation compartment is placed in a rail system that limits lateral or upward movement of the operation compartment;

wherein the weight of the device rests on the cord;

wherein the first motor has a shaft that creates a pivot point, allowing the control compartment to pivot in relation to the operation compartment, direction of the pivot determined by direction of rotation of the pulley.

20. The method of using the device of any one of claims 1-19.

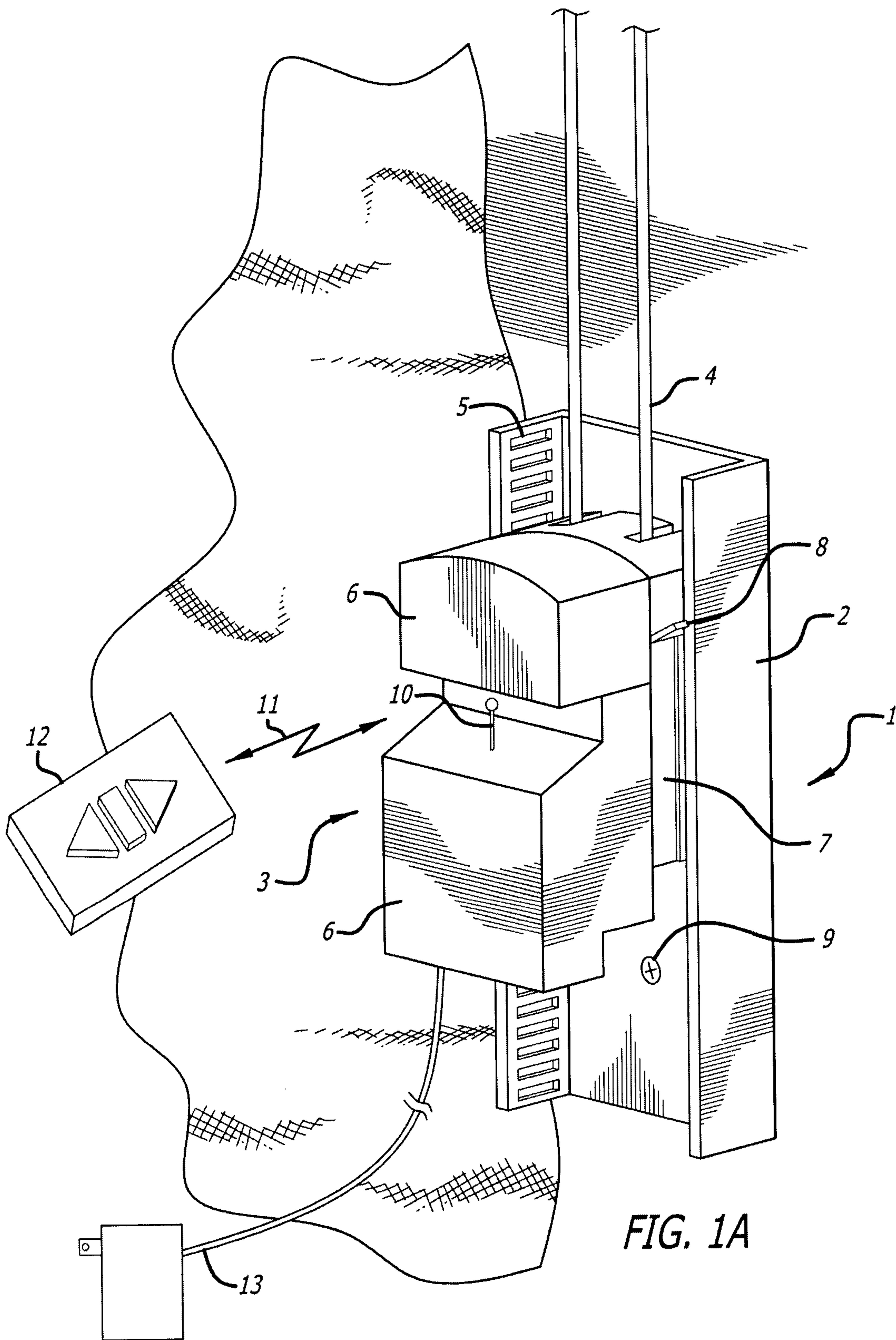

FIG. 1A

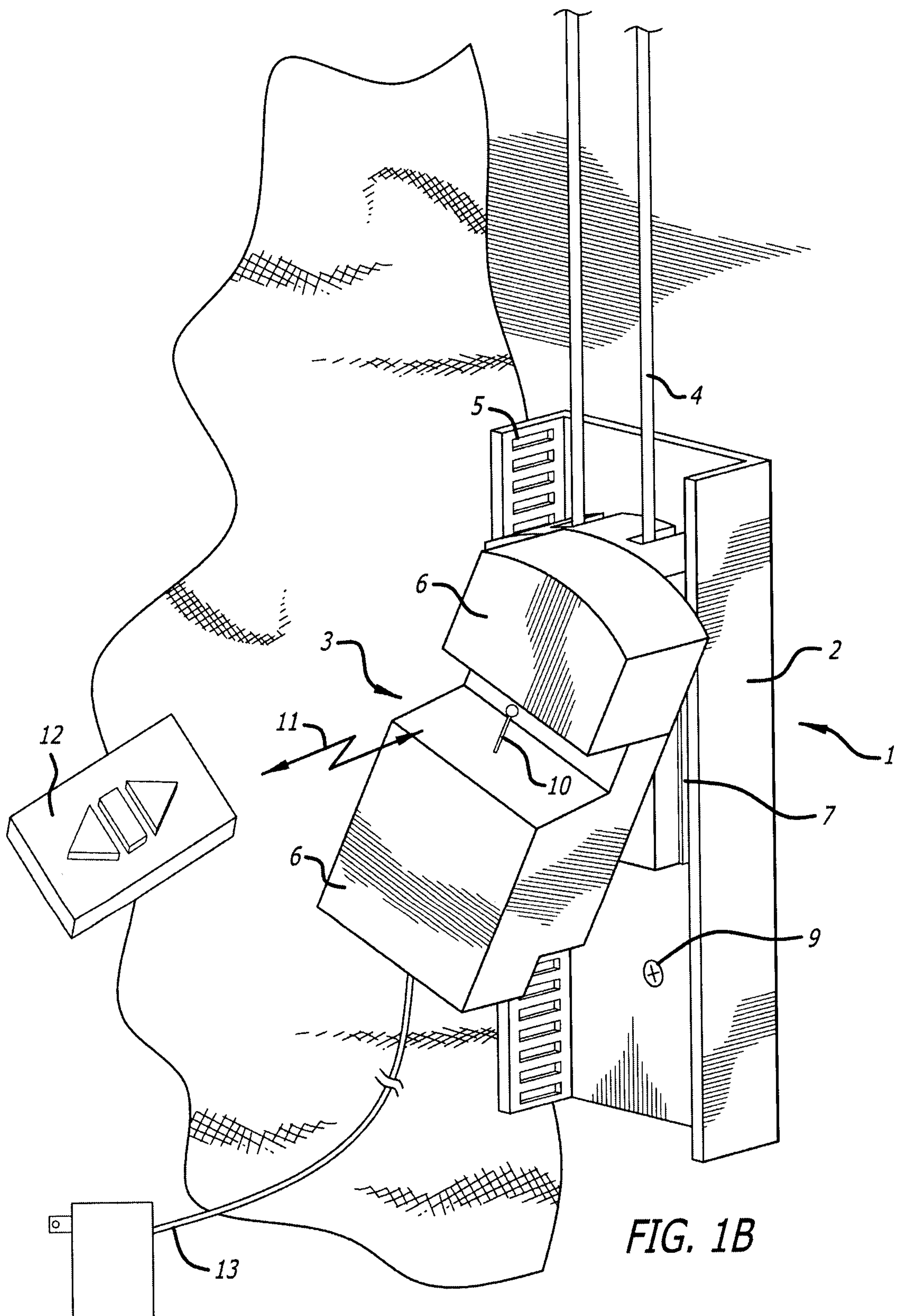

FIG. 1B

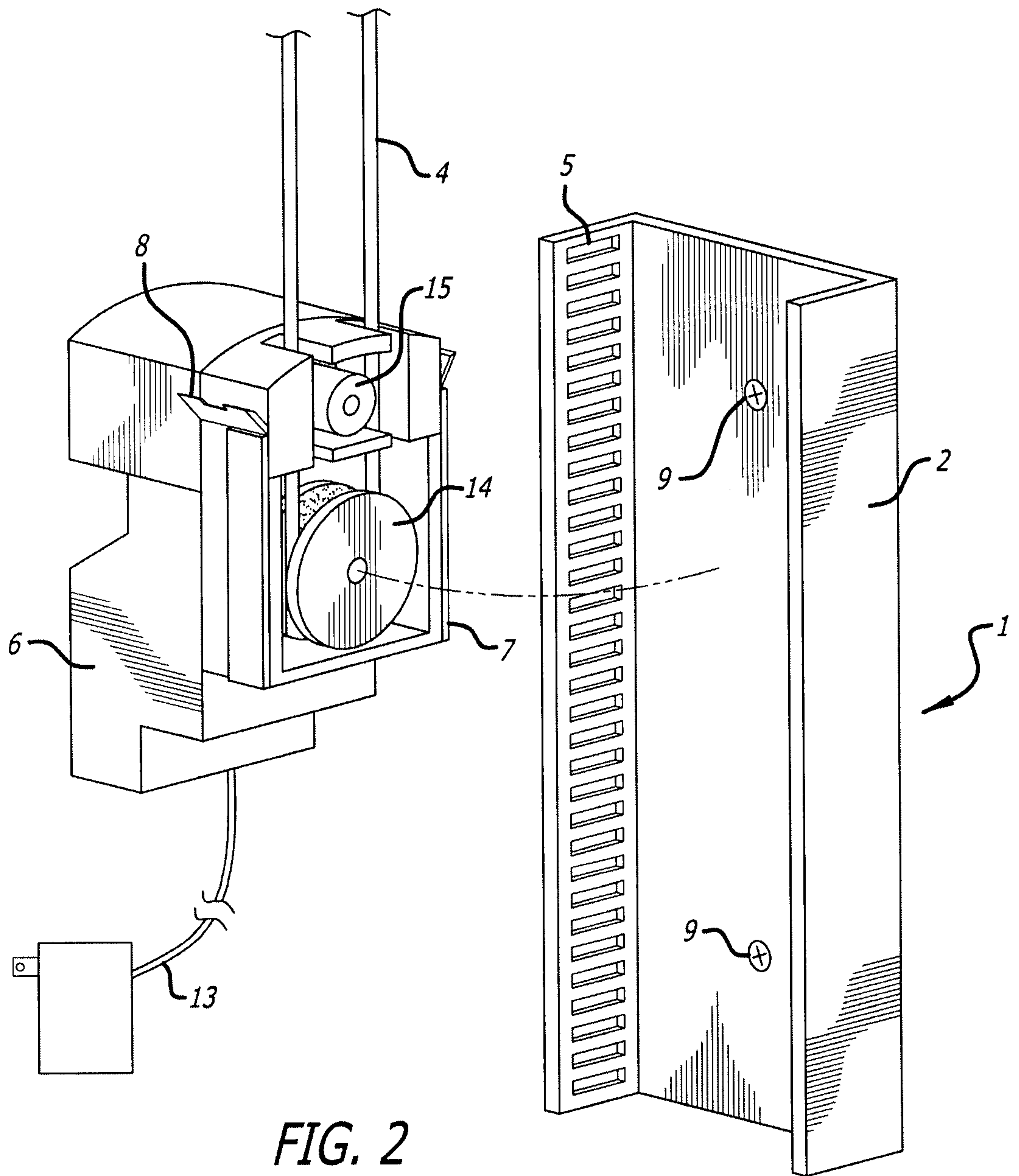
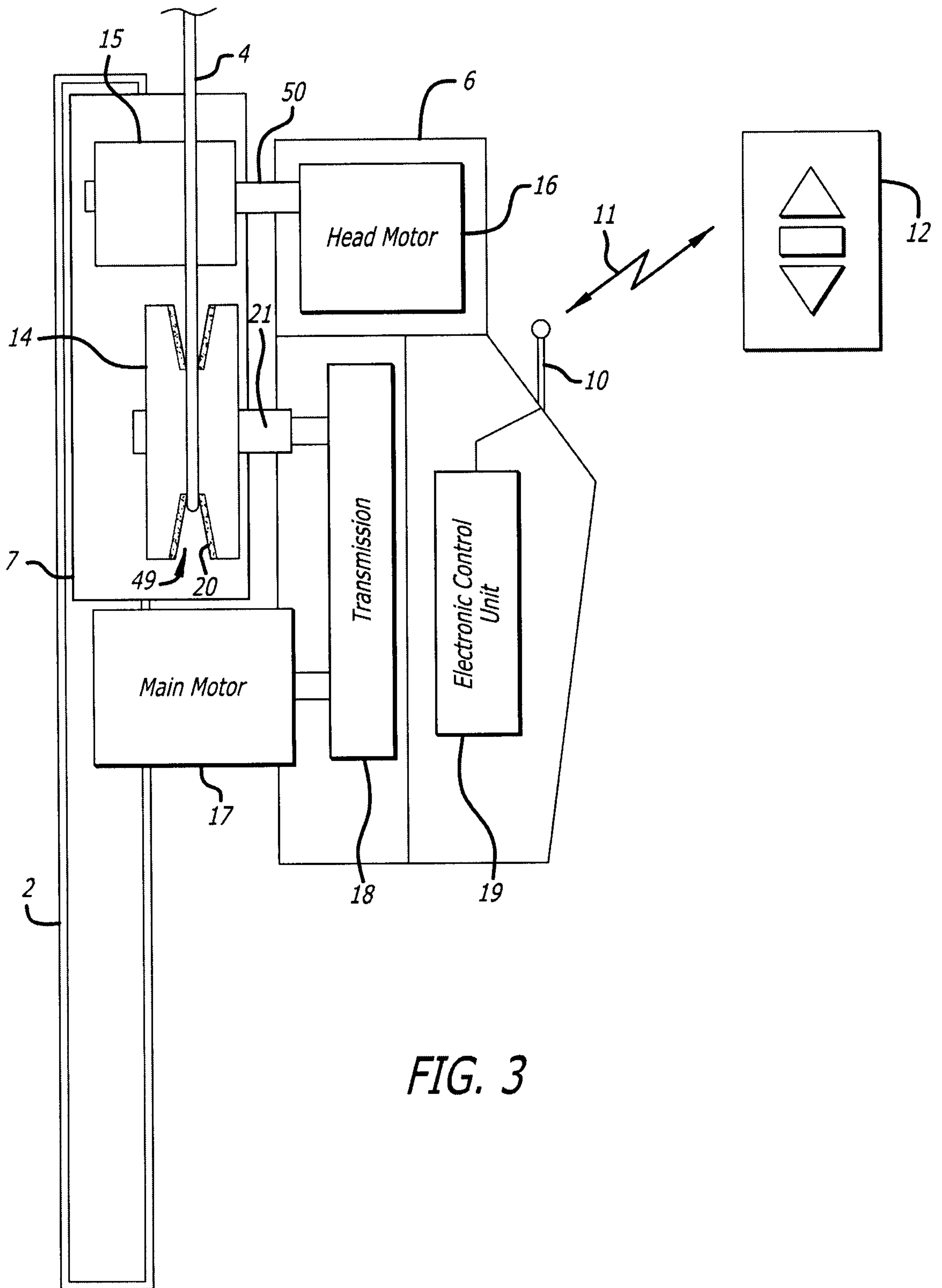

FIG. 2



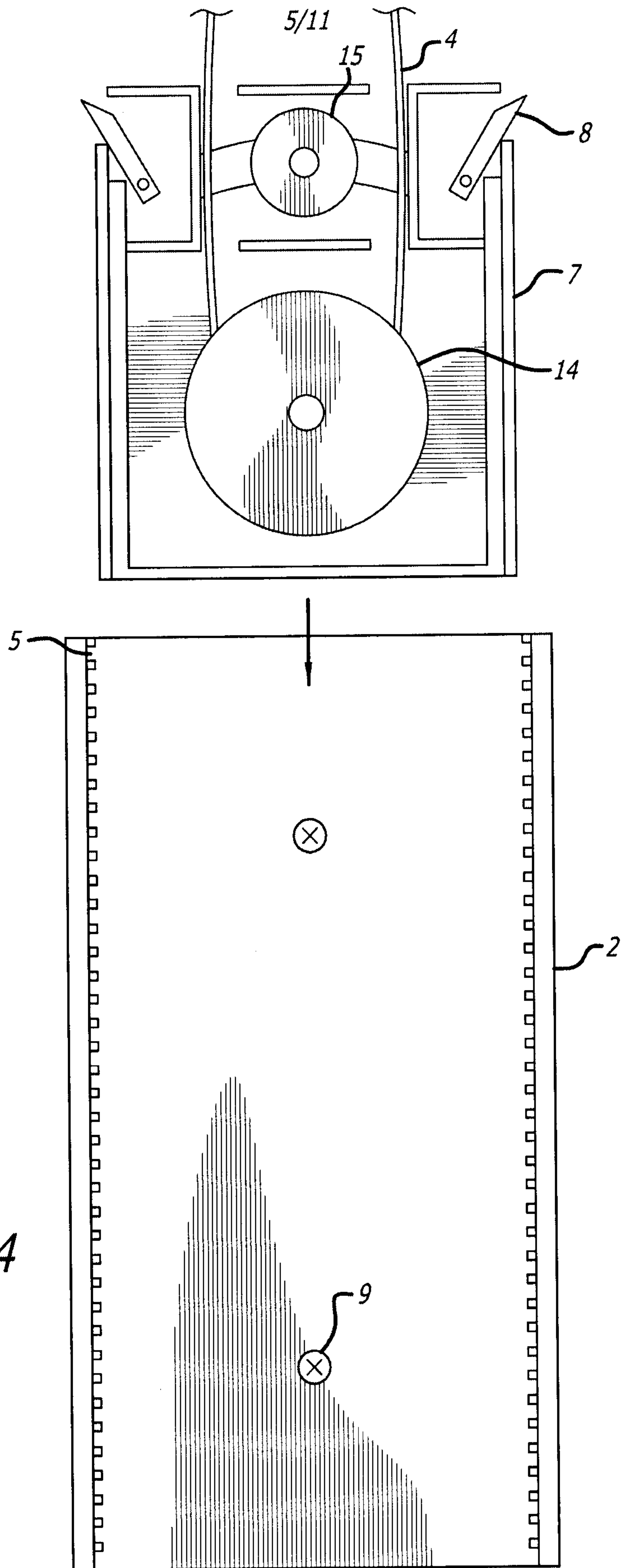

FIG. 4

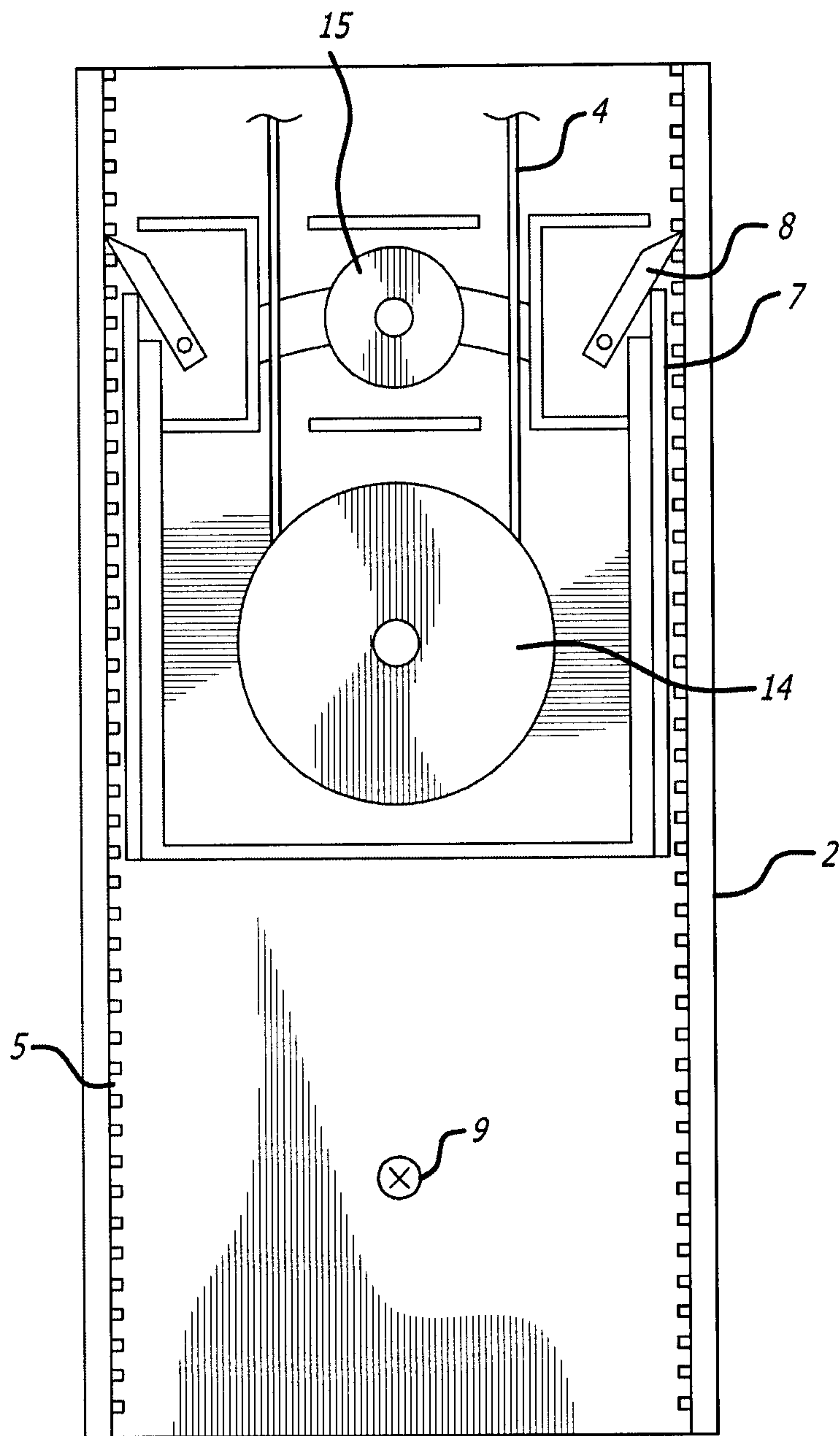

FIG. 5

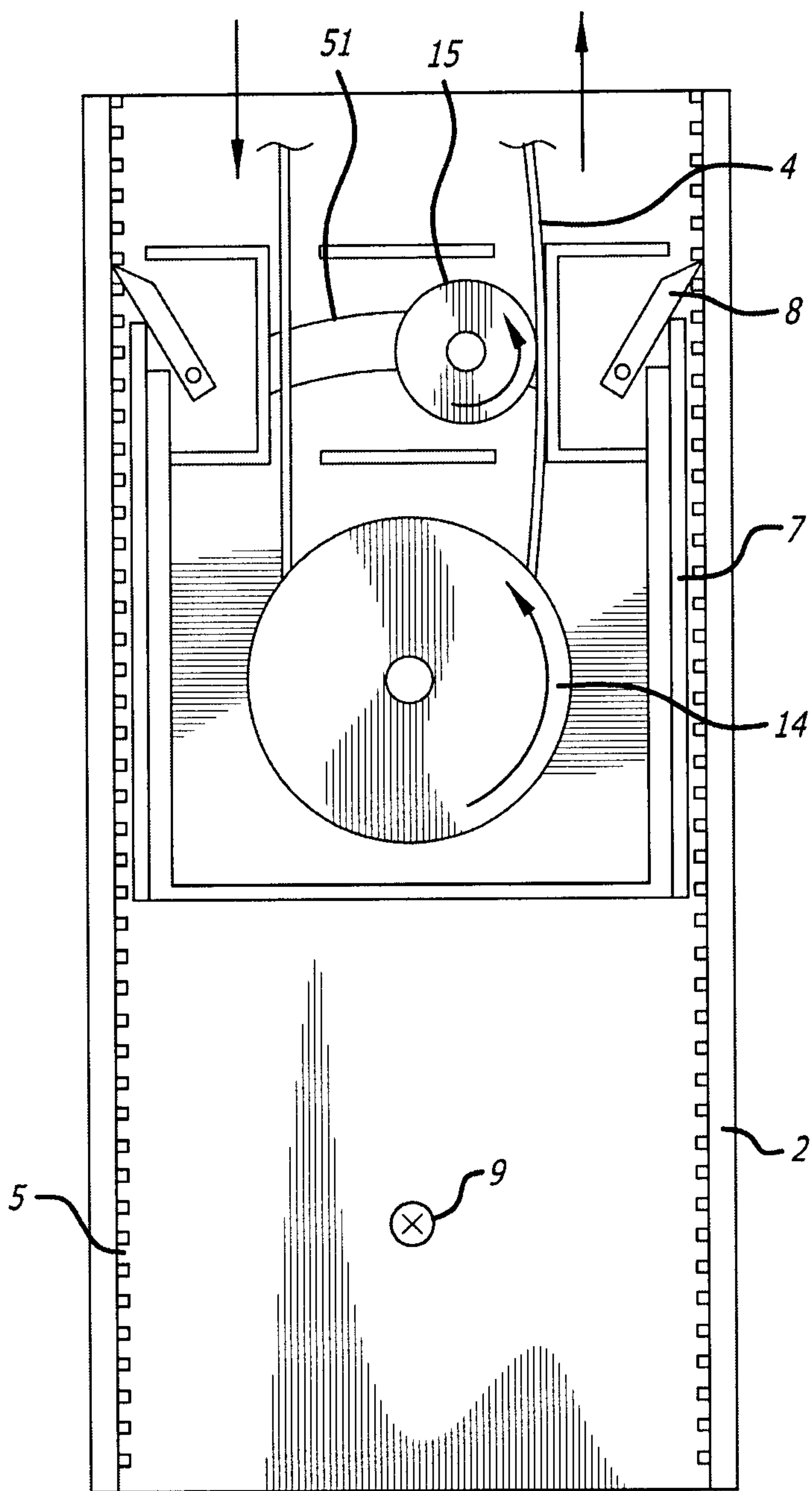

FIG. 6

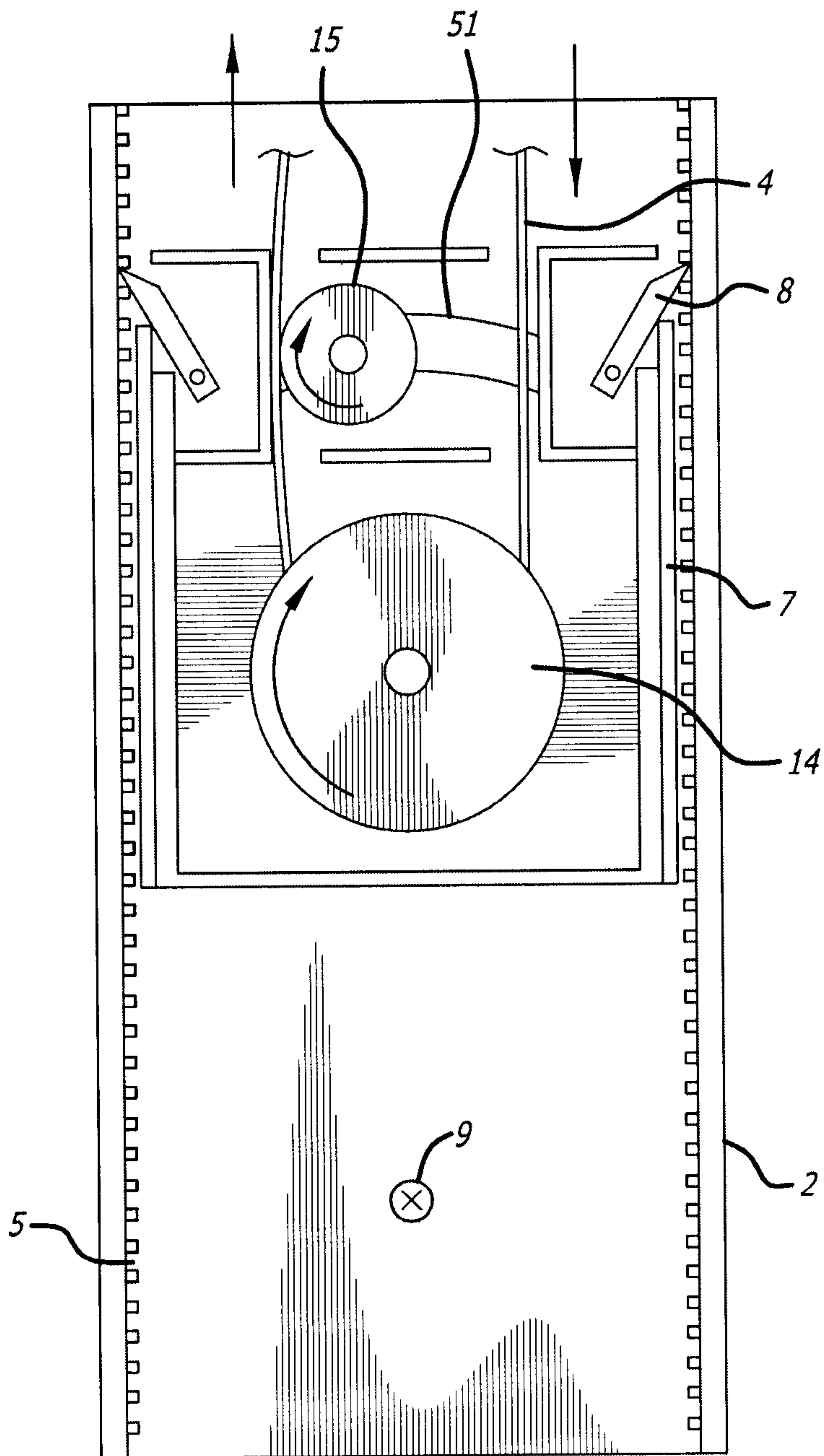

FIG. 7

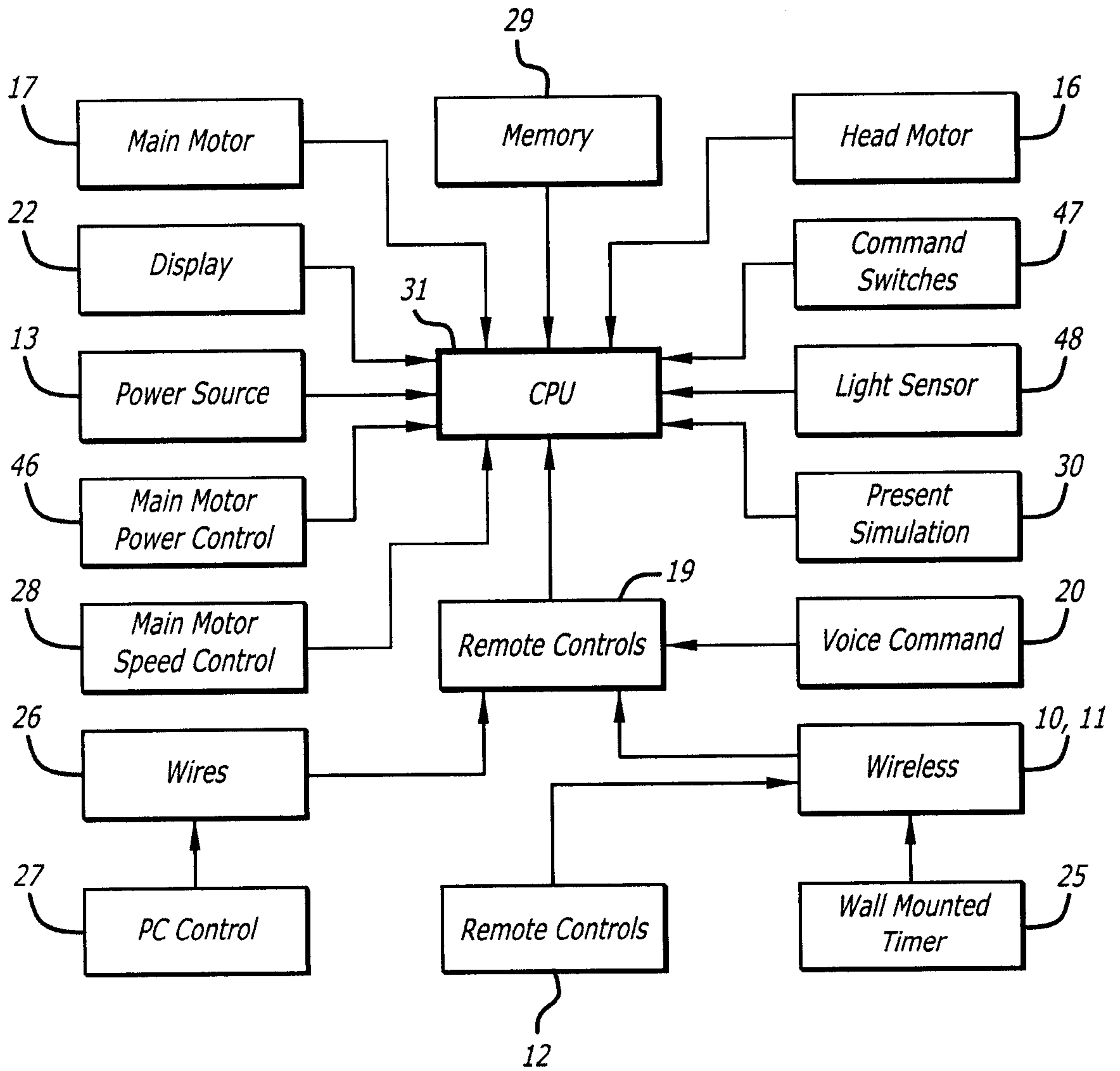
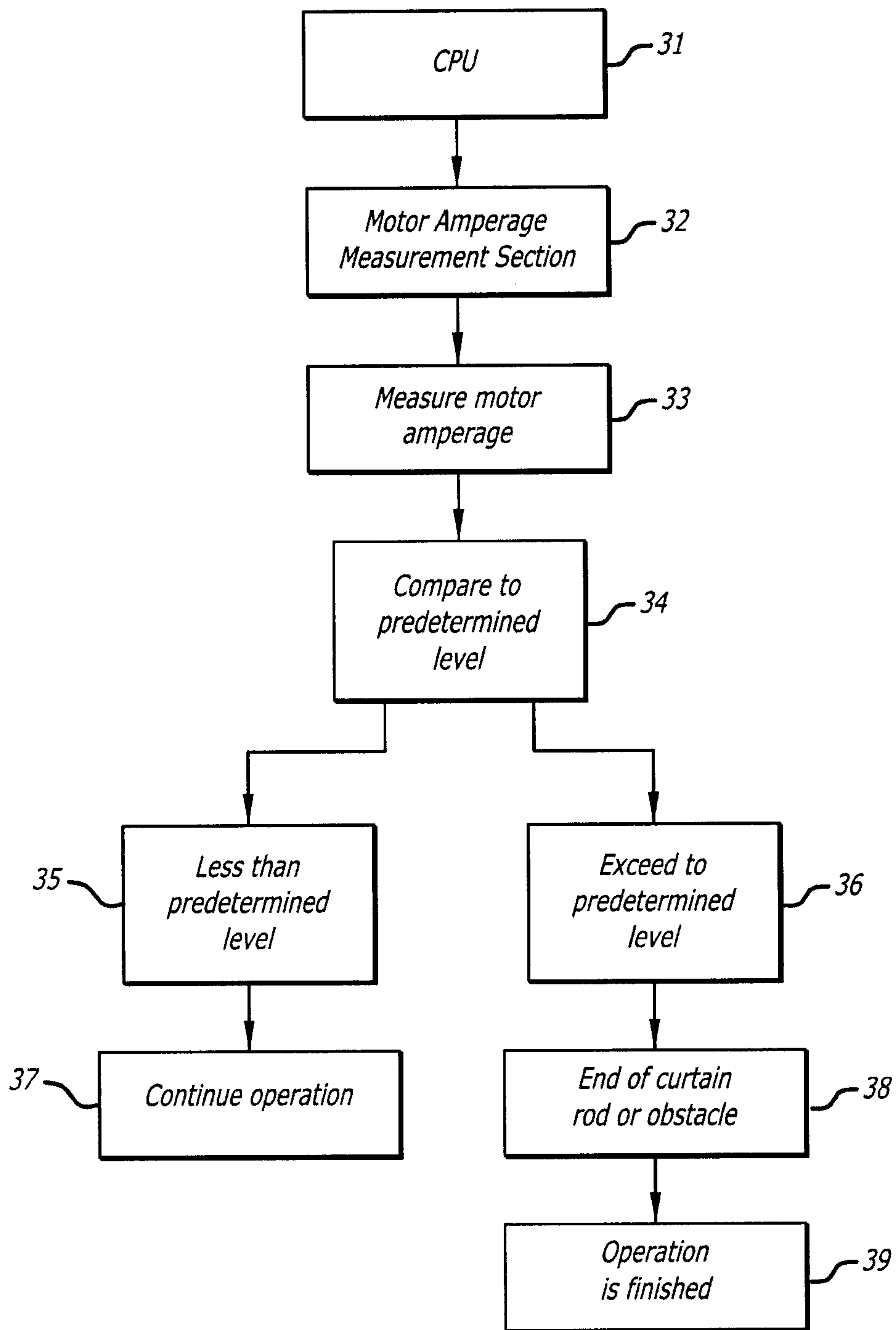

FIG. 8

FIG. 9



11/11

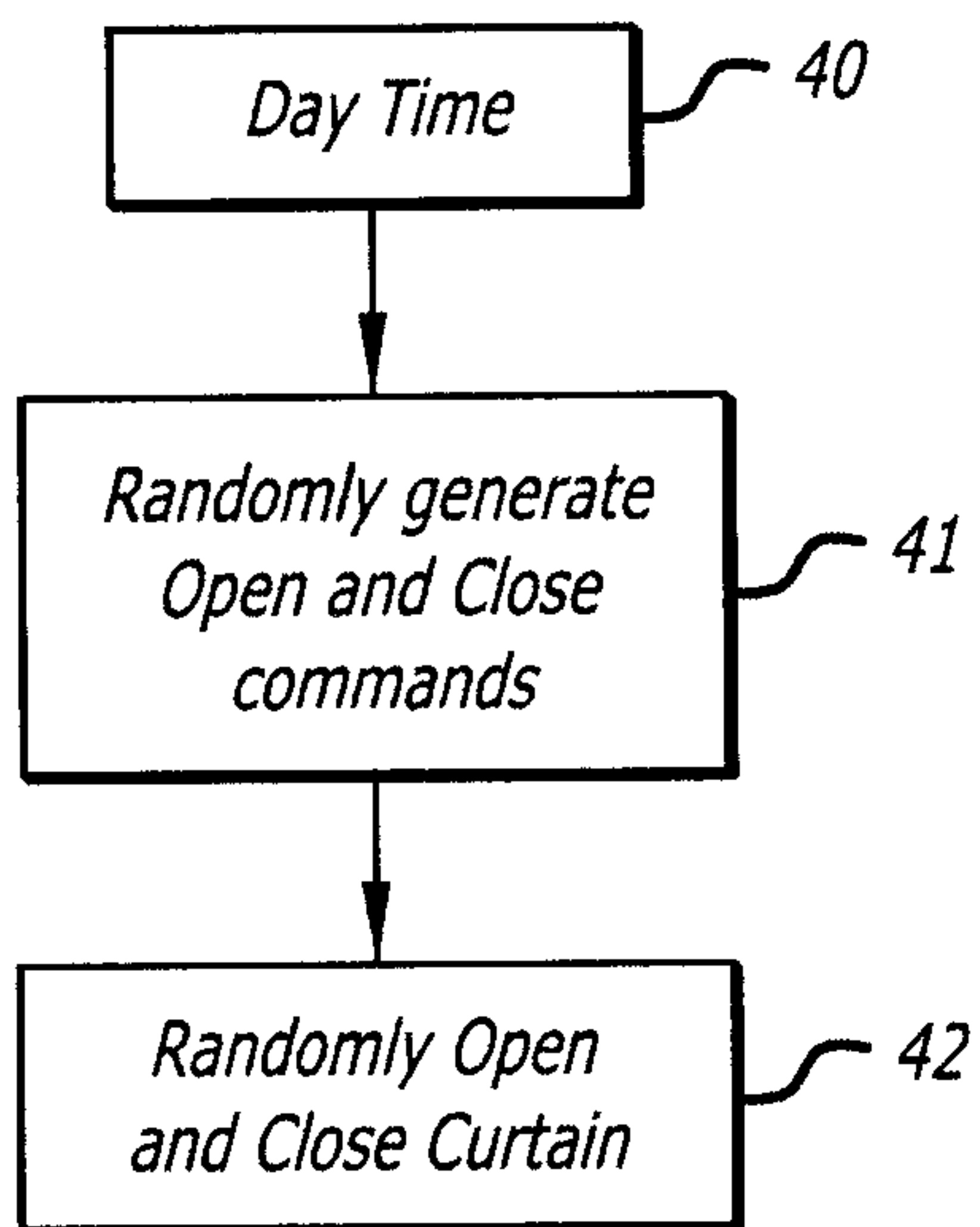

FIG. 10

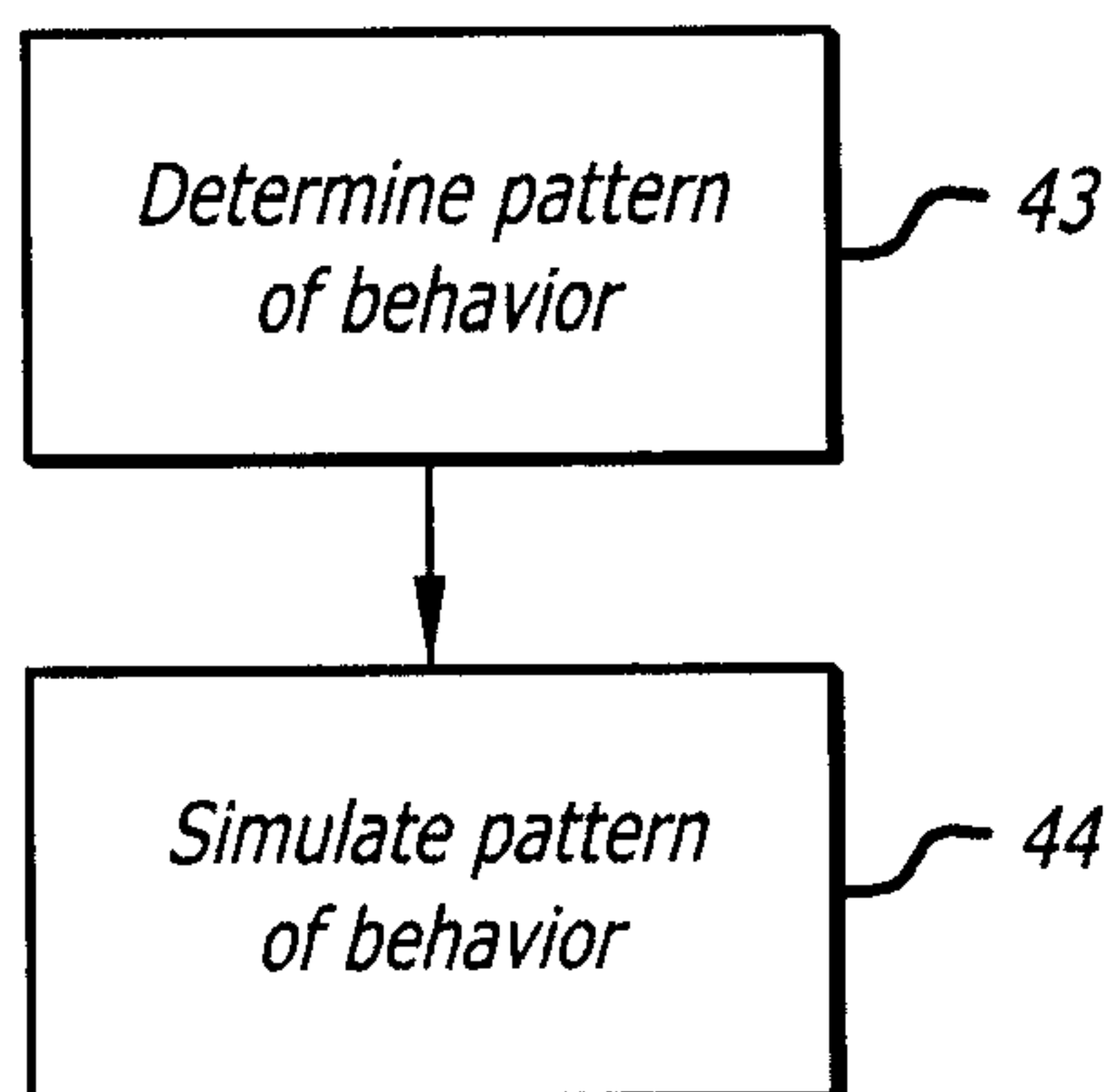

FIG. 11

