

(19) World Intellectual Property Organization
International Bureau



(43) International Publication Date
5 April 2001 (05.04.2001)

PCT

(10) International Publication Number
WO 01/24584 A1

- (51) International Patent Classification⁷: H05B 33/08
- (21) International Application Number: PCT/US00/26731
- (22) International Filing Date:
29 September 2000 (29.09.2000)
- (25) Filing Language: English
- (26) Publication Language: English
- (30) Priority Data:
60/156,672 29 September 1999 (29.09.1999) US
- (71) Applicant: COLOR KINETICS, INC. [US/US]; 50 Milk Street, Boston, MA 02109 (US).
- (72) Inventors: MORGAN, Frederick, M.; 157 Butler Road, Quincy, MA 02169 (US). LYS, Ihor, A.; Apartment #6, 5 Hull Street, Boston, MA 02133 (US).
- (74) Agents: PHAM, Chinh, H. et al.; Foley, Hoag & Eliot, LLP, One Post Office Square, Boston, MA 02109 (US).
- (81) Designated States (*national*): AU, CA, JP.
- (84) Designated States (*regional*): European patent (AT, BE, CH, CY, DE, DK, ES, FI, FR, GB, GR, IE, IT, LU, MC, NL, PT, SE).
- Published:**
— With international search report.
— Before the expiration of the time limit for amending the claims and to be republished in the event of receipt of amendments.
- For two-letter codes and other abbreviations, refer to the "Guidance Notes on Codes and Abbreviations" appearing at the beginning of each regular issue of the PCT Gazette.*

(54) Title: SYSTEMS AND METHODS FOR CALIBRATING LIGHT OUTPUT BY LIGHT-EMITTING DIODES

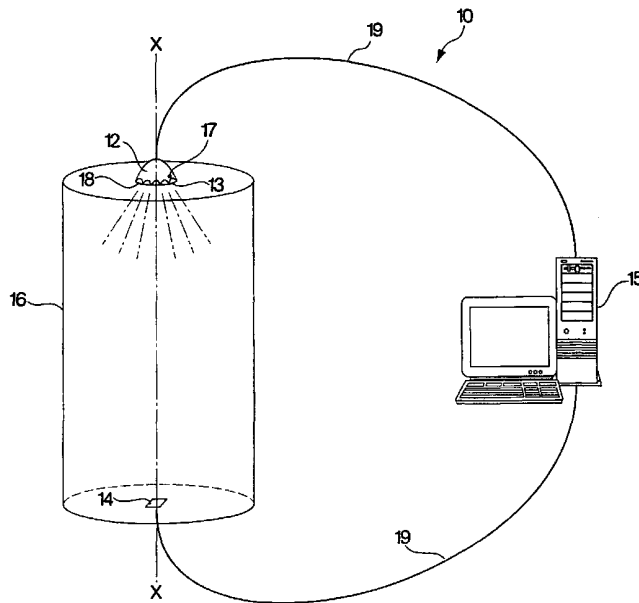

(57) Abstract: A system and method for calibrating light output from an LED is provided. The system includes a support on which an LED is positioned, a photosensor to measure the light output from the LED, and means for calibrating and adjusting the light output of the LED. Calibration is accomplished by measuring the light output from the LED, comparing such output against a reference value, and adjusting the measured output against the reference value.



WO 01/24584 A1

SYSTEMS AND METHODS FOR CALIBRATING LIGHT OUTPUT BY LIGHT-EMITTING DIODES

5 Technical Field

The present invention relates generally to light-emitting diodes, and more particularly, to systems and methods for calibrating illumination output generated by light-emitting diodes.

10 Background Art

Light-emitting diodes (LEDs), when disposed on a circuit, accept electrical impulses from the circuit and convert the impulses into light signals. LEDs are typically energy efficient and can have a long lifetime.

Various types of LED exists, including air gap LEDs, GaAs light-emitting diodes,
15 polymer LEDs, and semi-conductor LEDs, among others. Although most LEDs in current use are red, LEDs may take any color. In addition, when several LEDs, each of a commonly used primary color -- red, blue or green -- are combined in different proportions, the combination can generate almost any color in the visible spectrum in response to changing electrical signals. Alternatively, a single LED may be designed to
20 include dies, each with a primary color (i.e., red, blue, and green), which can be combined to generate almost any colors.

Traditionally, LEDs have been poor in their ability to generate sufficient light output for illumination. Accordingly, LEDs have been used in low light environments, such as a flashing light on a modem or other computer components, or as a digital display
25 of a wristwatch. However, over the past several years, the ability of the LEDs to generate sufficiently high intensity light output has increased substantially. Thus, LEDs have recently been used in arrays for flashlights, traffic lights, scoreboards and similar displays, and as television displays.

Despite this new development, the manufacturing of high-intensity LEDs, is still
30 a challenging process. In particular, it has been difficult to precisely predict the performance of an LED-based product in terms of total light output and quality of the output. Specifically, as an LED increases in output intensity, the quality of the output decreases.

In general, during manufacturing, the LEDs are tested for total light output and subsequently classified into "bins". Depending on the manufacturer, however, this classification can happen either after the semiconductor wafer has been sliced into individual dies or after the die is packaged into the LED plastic housing. In either case, 5 for each LED, a light output determination is made of both wavelength (the color of light) and intensity of the output. The LEDs are then sorted and sold based on the bin-type for which they have been classified.

It should be noted that even with bin sorting, there remain substantial and perceptible differences in the light output amongst LEDs. This difference, as a result, can 10 lead to perceptible differences in light output between otherwise identical LED-based products. Moreover, if "additive mixing" is employed, wherein a few LEDs of different colors are mixed to produce other colors, should the color in one or more of these LEDs be off, then the results of the additive mixture will also be off.

Furthermore, the light output from the LEDs may change over time as a result of a 15 variety of factors, and can also contribute to perceptible differences in light output. For instance, the LEDs may degrade or shift in color output over time, as part of a normal deterioration of the LEDs. In addition, long term exposure of the LEDs to high heat, or requiring the LEDs to maintain high intensity light output over an extended period of time, such that the LEDs produce too much heat, or if the heat can not be removed 20 sufficiently quickly away from the LEDs, such effects can accelerate the deterioration of the LEDs and lead to permanent changes in the LEDs.

Accordingly, it is desirable to provide a system which can calibrate and adjust the light output of each LED, so that uniformity in light output by the LED can be achieved, during manufacturing, and subsequently maintained during the lifetime of the LED, either 25 alone or in combination.

Summary of the Invention

The present invention, in accordance with one embodiment, provides a method for calibrating light output by a light-emitting diode (LED). The method includes generating 30 light output through the LED. Subsequently, measurement of the light output generated by the LED is obtained. Thereafter, the light output measurement is compared to a reference value designated for an LED of the type similar in classification (i.e., from the

same bin) to the LED being calibrated. Once the comparison is made, if there are any differences between the light output measurement and the reference value, the light output of the LED being calibrated is adjusted against the reference value. A calibration value is thereafter formulated from the adjustment of the output measurement against the
5 reference value. Subsequently, the calibration value may be stored in a manner which permits access by the calibrated LED, so that upon a subsequent generation of light output, the calibration value may be accessed to permit the calibrated LED to generate a light output that approximates an output accorded to the reference value. The light output, may be calibrated to adjust the intensity of the output, as well as the color of the
10 output by the LED. It should be noted that the calibration protocol of the present invention may be implemented in an environment where there is an existence or absence of ambient light.

In another embodiment, the present invention provides a system for calibrating light output by an LED. The system, in one embodiment, includes a support to which an
15 LED to be calibrated may be positioned thereon. The system further includes a photosensor, placed in a manner which permits receipt of light output by the LED, for obtaining an output measurement from the light output. The system further includes a processor in communication with the photosensor and for formulating a calibration value from an adjustment of the output measurement against a reference value. The processor
20 may also be in communication with the LED for transmitting thereto a resulting value from the calibration. A memory mechanism may be provided in association with the LED on which the resulting value from the calibration may be stored for subsequent accessed during light output generation by the LED.

The present invention also provides a calibration device for calibrating light output
25 from an LED. The device includes a support to which an LED to be calibrated may be positioned thereon, and a photosensor adjacent to the support for obtaining an output measurement generated by the LED. The device further includes a communication mechanism through which an output measurement from the photosensor may be communicated to a processor for formulation of a calibration value, and through which
30 the calibration value may subsequently be communicated to the LED and stored on a memory device coupled to the LED. The device, in one embodiment, may be a handheld device, and may include a display to provide to a user status of the light output of the

LED being calibrated. The device may also include an interface to permit the user to vary light output parameters for the LED; and a memory mechanism for storing the output measurement from the photosensor, which output measurement can subsequently be communicated to an off-site processor for calibration processing. In an alternate
5 embodiment, the device includes a calibration processor for therein for prompt and efficient calibration.

In accordance with another embodiment, a calibration device is provided for calibrating light output from an LED, while permitting the LED to remain within its illumination device (i.e., the LED does not have to be removed from the light fixture for
10 calibration). The calibration device includes a housing, an activation unit for inducing light output from an LED to be calibrated, and a photosensor at one end of the housing for obtaining an output measurement from the light output generated by the LED. The calibration device also includes a communication mechanism in the housing through which output measurement from the photosensor can be communicated to a processor for
15 formulation of a calibration value, and through which the calibration value may subsequently be received by the device and subsequently communicated to the LED in the illumination device. The device, in one embodiment, may be a handheld device, and may include a display to provide to a user status of the light output of the LED being calibrated, an interface to permit the user to vary light output parameters for the LED.
20 The device may also include a memory mechanism for storing the output measurement from the photosensor, which output measurement can subsequently be communicated to an off-site processor for calibration processing. In an alternate embodiment, the device includes a calibration processor.

The present invention further provides an illumination device having a housing, an
25 LED illumination source within the housing, and a photosensor adjacent to the LED illumination source to obtain an output measurement generated by the LED illumination source. The device also includes a processor within the housing and in communication with the photosensor for calibrating the output measurement from the photosensor against a reference value. The processor is also in communication with the LED for transmitting
30 thereto a resulting calibration value from the processor. The device further includes a memory mechanism coupled to the LED illumination source and on which the resulting calibration value from the processor may be stored. The device may also include a

display on which parameters regarding light output from the LED illumination source may be provided to inform a user of the status of the light output, and an interface to permit the user to vary the light output parameters.

5 Brief Description of the Drawings

The various advantages of the present invention will become apparent to one skilled in the art by reading the following specification and appended claims and by referencing the following drawings in which:

Fig. 1 illustrates, in accordance with an embodiment of the present invention, a
10 system for calibrating light output from a light-emitting diode.

Fig. 2 illustrates schematically calibration of light output in accordance with an embodiment of the invention.

Figs. 3A-B illustrate representative color peaks generated from an LED before calibration and after calibration.

15 Fig. 4 illustrates, in accordance with an embodiment of the present invention, a device for calibrating light output from a light-emitting diode.

Fig. 5 illustrates, in accordance with another embodiment of the invention, a device for calibrating light output from a light-emitting diode.

20 Fig. 6 illustrates, in accordance with one embodiment of the invention, an illumination device capable of calibrating the light output of its light-emitting diodes.

Detailed Description of Specific Embodiments

Referring now to the drawings, in Fig. 1, there is shown a system 10 for calibrating light output from a light-emitting diode (LED). The system 10, in one
25 embodiment, includes a support 12, on which an LED 13 or multiple LEDs 13 to be calibrated may be positioned. The support 12 may also accommodate a module (not shown) with multiple LEDs 13 therein, similar to those modules used in connection with various LED illumination devices. Such a module is disclosed in U.S. Patent No. 6,016,038, which is hereby incorporated herein by reference.

30 The system 10 also includes a photosensor 14 for measuring the photometric output (i.e., light output) the LED 13. For the ease of discussion, reference will be made to a single LED 13, with the understanding that the system 10 is capable of calibrating

multiple LEDs. The photosensor 14, may be placed in any location relative to the LED 13, so long as the photosensor 14 can receive the output by the LED 13. Accordingly, the photosensor 14 may, for instance, be adjacent to the LED 13, or in substantial alignment with the LED 13, as illustrated in Fig. 1. An example of a photosensor which may be
5 used in connection with the system 10 for obtaining an output measurement from the LED 13 is a photosensor manufactured by Ocean Optics Device, which can measure the color output, as well as intensity of the output.

In addition to a photometric sensor, other types of sensors may be used to measure the light output of the LED 13. Examples of sensors which may be used include, but not
10 limited to, a photometer, spectrophotometer, spectroradiometer, spectrum analyzer, spectrometer, CCD, photodiode, photocell, and thermocouple.

A processor 15 may be provided in communication with the photosensor 14 to calibrate and adjust the output measurement received from the photosensor 14 against a reference value for intensity and/or color for such an LED. (A detailed description of the
15 calibration process will be described hereinafter below.) The processor 15 may also be in communication with the LED 13, so as to transmit to the LED 13 a calibration value (obtained from the calibration and adjustment of the output measurement against the reference value) for adjusting the ultimate output by the LED 13, whether such
20 adjustment is with respect to intensity or color. It should be appreciated that the calibration value, when taken into account during periods of light output by the LED 13, subsequent to the calibration, permits the light output from the LED 13 to approximate an output accorded to the reference value.

As LEDs are highly responsive to changing electrical signals, i.e., changes in the LED color and intensity state may be quite rapid in response to changing electrical
25 signals, the processor 15 may be controlled by, for example, a computer program, to send the appropriate electrical signals to the LED 13 being calibrated. The signals from the processor 15 sent to the LED 13 may also be digital in nature, so that calibration of the LED 13 may be as precise as possible. As shown in Fig. 1, the processor 15 may be part of computer. However, it should be appreciated that the processor 15 may be part of any
30 device capable of providing the processor with appropriate signals.

The system 10 further includes a memory mechanism 16 in association with the LEDs 13, and on which the calibration value for use in adjusting the light output by the

LEDs 13 is stored. Memory mechanism 17 may be any commercially available memory mechanism having data storing capability. In one embodiment of the invention, the memory mechanism 17 is physically coupled to the LEDs 13, so that once the calibration value has been stored thereon, the memory mechanism 17 can be removed from the
5 support 12 along with the LEDs 13. Upon subsequent generation of light output from the LED 13 in, for example, an illumination device, the calibration value on the memory mechanism 17 can be accessed to affect the output generated from the LED 13. In other words, the calibration value permits the light output from the LED to approximate light output accorded to a reference value for that type of LED.

10 Still referring to Fig. 1, the system 10, in accordance with one embodiment of the present invention, includes a housing 16 extending from the support 12 to the photosensor 14. The housing 16, in one embodiment, may be an enclosed structure configured to encompass the support 12 and the photosensor 14, so as to block ambient light from interfering with measurement of the LED light output by the photosensor 14 during
15 calibration. The housing 16 may also be provided with an opening 18 through which the LED 13 can access within the housing and be positioned on the support 12.

As shown in Fig. 1, communication between the processor 15 and either of the LED 13 or the photosensor 14 can be implemented by a cable 19. Alternatively, a wire, network, or a combination thereof may be employed in place of cable 19. It should be
20 appreciated that communication between the processor 15 and either of the LED 13 or the photosensor 14 can be by wireless means, including but not limited to, radio frequency (RF), infrared (IR), microwave, electromagnetic transmission, acoustic, Bluetooth, home RF, or other wireless means.

The system 10 can be used to calibrate light output, such as light intensity, from an
25 individual LED or multiple LEDs. Alternatively, the system 10 can be used to calibrate the color illumination of an LED having multiple color dies, or multiple LEDs, each of different color. The need to calibrate the color illumination can be important, especially when color mixing is involved, where the cumulative output of the individual die in one LED, or of multiple color LEDs can be affected by any perceptible differences between
30 the dies or LEDs of the same color. For example, when Red, Green and Blue dies are used in one LED or when groups of Red, Green and Blue LEDs are used to generate a range of color within a color spectrum, including white light, even after appropriate

circuit implementations, if there are any malfunctioning dies or LEDs, those malfunctioning dies or LEDs can generate very different light intensity and color outputs, thereby affecting the overall light output. These differences can often be seen in older LEDs (i.e., after the LEDs have been in use for some time), and can sometimes be observed in new LEDs, even in those newly manufactured. Accordingly, it is useful to calibrate newly manufactured LEDs or recalibrate used LEDs, so that a desired light output can be achieved.

Calibration may be accomplished, in an embodiment, through the use of photosensor 14. As shown in Fig. 1, the photosensor 14 and LED 13 can be positioned within the housing 16 along axis X and facing towards one another. Although the photosensor 14 and the LED 13 can be in alignment, it should be appreciated that their position relative to one another can be in any arrangement, so long as the photosensor 14 is capable of receiving the light output from the LED 13 in a uniform manner.

Referring now to Fig. 2, a process for calibrating light output is shown therein. Once the LED 13 is in position for calibration, as indicated in item 21, the LED 13 may be caused to generate a light output 22. If multiple LEDs 13 are being calibrated, each LED in the group may be caused to generate light output in sequential fashion. As each LED 13 generates its light output, for example, red, green or blue, the photosensor 14 records, in step 23, a peak measurement from the light output, and assigns, in step 24, as a spectral response, a relative value for the peak measurement. As shown in Fig. 3A, the peak value for the light output can vary widely. In step 25, the peak value for each individual output may be compared to a reference value (e.g., within a table of reference value) that had previously been established as representative for an LED of that type. If there are any differences between the peak value and the established reference value, the peak value for that individual output is adjusted, in step 26, by scaling that individual output to the reference value. The adjustment of the light output in this manner can result in the higher peaks being reduced (i.e., scaled) to match the value of the lower peaks, see Fig. 3B, to provide a uniform light output. It should be noted that several iterations (i.e., adjustments) may be needed to get an adjusted peak value that closely resemble the reference value. Moreover, in a situation wherein calibration of a plurality of LEDs 13 is required, once calibration for one LED is completed, calibration for the next LED can be initiated.

In adjusting the output, a calibration value may be formulated. The calibration value for the light output of each LED 13 may then be stored, in step 27. This calibration value, once stored, can replace previous calibration settings, if any, and can be employed in all future/subsequent generation of light output by the LED 13. Storage of the
5 calibration value can be accomplished by providing the LED 13 with a memory chip 16 (see Fig. 1). In this manner, when commands are sent to the LED 13 for generating a light output, the stored calibration value for that particular LED may be accessed from the memory chip and used to permit the LED 13 to generate a light output which approximates a light output accorded to the reference value.

10 As indicated previously, the system 10 of the present invention may be used to adjust differences in the color output by an LED 13 when compared against a reference output. In addition, the system 10 may also be used to adjust the intensity of the light output by an LED.

The system 10 can further be used to check and/or diagnose a variety of other
15 potential problems by analyzing the light output of the LED. For example, the system 10 can check to see whether the light output intensity of an LED is not in compliance with the reference output value. If such is the determination, the finding can indicate a circuit problem, missing LEDs, or LEDs incorrectly placed during the assembly process.

The system 10 may also be used to determine if there has been any LED placement
20 errors during the LED board assembly. In particular, a discrepancy between a measured color value and referenced color value may indicate that one or more of the LEDs may have been placed improperly, e.g., a green LED in a red location or some other incorrect combination, during assembly.

If a substantial hue difference is detected, such may indicate that a particular
25 run/batch of LEDs may have been improperly made, resulting in off-color LEDs.

The information obtained when employing the system 10 can also be used to identify problematic trends in the LED manufacturing process. For instance, the information may be used to determine whether the overall output by the LEDs is changing (i.e., deteriorating over time) for each batch of LEDs produced by comparing the initial
30 information logged on the computer running the calibration software against the information from the latest batch.

As a note, should photosensor 14 or any of the listed sensors become unavailable, the system 10 is designed so that human eyes may be employed in the calibration, where a user could employ the processor 15 to calibrate the light output from the LED according to his subjective settings.

5 Looking now at Fig. 4, Fig. 4 illustrates, in accordance with an embodiment of the present invention, a device 40 for calibrating light output from a light-emitting diode. The device 40. The device 40 includes a support 41, to which an LED 42, for instance, newly manufactured, or from an illumination device (not shown), may be positioned thereon for calibration. The device 40 also includes a photosensor 43 adjacent to the support 41 for
10 obtaining an output measurement generated by the LED. The photosensor 43 may be placed in any location relative to the LED 42, so long as the photosensor 14 can receive the output by the LED 42. Accordingly, the location of the photosensor 14 may be adjustable within the device 40, so that for example, the photosensor 14 may be moved adjacent to the LED 42, or into substantial alignment with the LED 42.

15 The device 40 further includes a communication mechanism, such as port 44. The port 44 may be designed to be in coupling communication with the photosensor 43, so that an output measurement from the photosensor 43 may be communicated to a processor 45 for formulation of a calibration value. The port 44 may also be designed to be in coupling communication with the LED 42, so that data, such as the calibration
20 value, from the processor 45 may be received and relayed to the LED 42. Communication between the processor 45 and the port 44 may be by conventional cables 46, or by wires, network or a combination thereof. Alternatively, communication between the processor 45 and the port 44 may be by wireless means 47. Such wireless means include, but are not limited to, RF, IR, microwave, electromagnetic transmission,
25 acoustic, Bluetooth, home RF, or other wireless means.

 In employing wireless communication means, the port 44 may be provided with a transmitter 48, coupled to the photosensor 43, and a receiver 49, coupled to the LED 42. Alternatively, the port 44 may be provided with a transceiver (not shown). The transmitter 48 and receiver 49 used in connection with the present invention are those
30 commercially available, and of the type for receiving the signals provided herein.

 It should be appreciated that the calibration value received from the processor 45 through the port 44 may be forwarded to the LED 42, and subsequently stored on a

memory mechanism 491 in association with the LED 42. The memory mechanism 491, in one embodiment, may be physically coupled to the LED 42. The calibration value, as noted earlier, may be used in adjusting the light output of the LED, so that the light output approximates an output accorded to a reference value against which the calibration value
5 was formulated.

The device 40, in one embodiment, may be a handheld device, and may include a display 492, on which parameters regarding light output from the LED 42 may be provided to inform a user of the status of the light output from the LED 42. The display 492 may provide information such as flux, candle power, energy, luminescence, color,
10 CCT, CRI, x-coordinate, y-coordinate, or any other measurable parameter. The device 40 may also be provided with an interface 493 to permit the user to vary light output and/or parameters for the LED. In an alternate embodiment, instead of providing the device 40 with display 492 and user interface 493, information regarding the light output may be communicated through the port 44 to a unit having processing and display capability,
15 such as a computer 45, to permit display and adjustment of the light output and the parameters from the LED 42. Communication of the information through the port 44 can be by conventional cables or by wireless means, as provided above.

The device 40 may also include a memory mechanism 494, separate from the memory mechanism 491 coupled to the LED 42. The memory mechanism 494 may be
20 used for storing the output measurement from the photosensor 43 and other light output parameters, all of which can subsequently be communicated to an off-site processor 45 for calibration processing. In an alternate embodiment, the device 40 may incorporate the processor 45 within the device 40 to permit, for example, calibration to be carried out in a timely and efficient manner, without the need to communicate with an off-site processor.
25 Once the calibration is completed, the process stops and the LED 42 may be removed and returned to its illumination device.

In Fig. 5, another calibration device 50 is provided, in accordance with an embodiment of the present invention. The device 50 is similar to the device 40, illustrated in Fig. 4, except that the device 50 can be configured to calibrate the light
30 output of an LED 52, without having to remove the LED 52 from the illumination device within which the LED 52 sits.

The calibration device 50, as shown in Fig. 5, includes a housing 51 and a photosensor 53 at one end of the housing 51 for obtaining an output measurement from the light output generated by the LED 52. The photosensor 53 may be affixed at one end of the housing 51, or may be adjustable to alter its position within the housing 51. As the
5 LED 52 will remain within the illumination device and will not be positioned on the device 50 during calibration, the calibration device 50 may be provided with an activation unit 54 for inducing light output from the LED 52. To activate the LED 52 to generate a light output, the activation unit 54 may send a signal directed at the LED 52. To this end, the illumination device or the LED 52 itself may be designed with the ability to receive
10 the signal from the activation unit 54. The signal from the activation unit 54 can be sent by conventional cable or wirelessly. In the wireless embodiment, the device 50 may include a transmitter 55 coupled to the activation unit 54 to transmit the signal. Correspondingly, the illumination device can be provided with a receiver (not shown) coupled to the LED 52 to receive the signal transmitted from the activation unit 54.

15 The calibration device 50 may also include a communication mechanism, such as a port 56, in the housing 51, similar to port 44 in device 40. In particular, the port 56 may be designed to be in coupling communication with the photosensor 53, so that an output measurement from the photosensor 53 may be communicated to a processor 57 for formulation of a calibration value. The port 56 may also be designed so that data, such as
20 the calibration value, from the processor 57 may be received by the device 50, and subsequently relayed to the LED 52. The port 56 may employ conventional cables for communication or may employ wireless means, such as a transmitter or receiver, as described above. In one embodiment, the transmitter in connection with the port 56 and transmitter 55, used to transmit activation signals to the LED 52, may be a single
25 transmitter.

The device 50, in one embodiment, may include a display 58, on which parameters regarding light output from the LED 52 may be provided to inform a user of the status of the light output from the LED 52. The device 50 may also be provided with an interface
59 to permit the user to vary light output and/or parameters for the LED. The device 50
30 may also include a memory mechanism 591. The memory mechanism 591 may be used for storing the output measurement from the photosensor 53, as well as other light output parameters, all of which can subsequently be communicated to an off-site processor 55

for calibration processing. In an alternate embodiment, the device 50 may incorporate the processor 57 within the device 50 to permit, for example, calibration to be carried out in a timely and efficient manner, without the need to communicate with an off-site processor.

Looking now at Fig. 6, the present invention further provides an illumination
5 device 60 which may be capable of self calibration. The device 60 may be similar to the module in U.S. Patent No. 6,016,038, and includes a housing 61, and an LED illumination source 62 within the housing 61. A photosensor 63 may be positioned adjacent to the LED illumination source 62 to obtain an output measurement generated by the LED illumination source 62. The position of the photosensor 63 relative to the LED
10 illumination source 62, in one embodiment, permits the photosensor 63 to uniformly records the light output from the source 62.

The device 60 may also include a processor 64 within the housing 61 and in communication with the photosensor 63 for calibrating the output measurement from the photosensor 63 against a reference value. The processor 64 may also in communication
15 with the LED illumination source 62 for transmitting thereto a resulting calibration value from the processor 64. This calibration value may be used to affect the light output of the source 62, such that the output approximates an output accorded to the reference value. In one embodiment, the calibration process may be part of a feedback loop where the processor 64 monitors the light output from the source 62 via the photosensor 63 and
20 automatically communicates the calibration value to the illumination source 62 to permit the light output to compensation for any changes.

The device 60 further includes a memory mechanism 68 coupled to the LED illumination source 62 and on which the resulting calibration value from the processor 64 may be stored. In one embodiment, the device 60 may include a display 65 on which
25 parameters regarding light output from the LED illumination source 62 may be provided to inform a user of the status of the light output. The device 60 may further include an interface 66 to permit the user to vary the light output parameters.

By providing the device 60 with the above components, the device 60 may be activated to self-calibrate periodically. For instance, parameters regarding the
30 illumination source 62 may be reviewed on the display 65. Should the illumination source 62 require calibration, the interface 66 may be accessed and the calibration process initiated. Once the calibration is completed, and the illumination source 62 can now

generate a light output that approximates, for example, a light output defined by the user by way of the interface 65, the calibration ceases. In an embodiment of the invention, the device 60 may be designed to have the processor 64 initiate calibration, for instance, on a periodic basis, within certain predefined intervals, or in response to a particular condition, so that the light output from the illumination source 62 may be kept at a desired predefined level. Again, once calibration permits the illumination source 62 to achieve the desired light output level, the calibration ceases.

The systems, methods and devices provided in connection with the present invention may be used to calibrate an LED light source for a number of reasons, including but not limited to, intensity, color (hue or saturation), specific spectral properties, ambient conditions, internal temperature conditions, external ambient conditions or failure feedback (such as when one or more LEDs fails to operate).

While the invention has been described in connection with the specific embodiments thereof, it will be understood that it is capable of further modification. For example, the calibration value, although discussed as capable of being stored in a memory mechanism associated with the LED or in a memory mechanism on a calibrating device, can also be stored in the housing of an illumination device, or in a stand-alone device such as a computer. The calibration value can additionally be used as a reference value against which other calibration values may be adjusted against. As a reference value, the calibration value, like other reference values used in the present invention, may be formatted within a table. In addition, reference value against which the output measurement may be adjusted can be any defined value, for example, a value obtained from the measurement of environmental lighting. Specifically, the photosensor may be used to take a reading of ambient light in a room. Such a reading and its associated value may be stored as a reference value. Subsequently, during calibration, the LED output may be adjusted to approximate the ambient light condition within the room.

Moreover, the calibration procedure, in accordance with an embodiment of the invention, may be accomplished through a network of lighting devices. In particular, the calibration value may be used to adjust the illumination properties of a new device so that it may be similar to the illumination properties of other devices in the network. As an example, a new lighting unit within a network can receive signals from the other devices to which may initiate a calibration process in the new lighting unit. Information

contained in the signals such as, but not limited to, age of the illumination devices within the network, the manufacturing date of the illumination devices, the illumination conditions of such devices, or combinations of parameters (such as age, manufacturing date, and previous calibration data), may cause the new lighting unit in the network to
5 initiate a calibration procedure. In particular, as the older illumination devices in the network may be of a different quality, for example, they have lower light output, or they may have aged and deteriorated. By permitting the new lighting unit to calibrate, the new lighting unit would match the older illumination devices in the network.

The network of lighting units described may communicate through any
10 communications method, such as but not limited to, wire, cable, network, RF, IR, microwave, acoustic, or electromagnetic communication. The units in the network may communicate other instructions along with the calibration information, or the units may only communicate the calibration information. In addition, there may be instances where the lighting units may be used in a networked fashion to allow coordinated lighting
15 effects. The calibration information could be communicated using this network or a network specifically for calibration information. Moreover, the LEDs within the lighting units may also be used to communicate the calibration information to the other lighting units, for instance, by pulsing in a particular pattern.

Furthermore, this application is intended to cover any variations, uses, or
20 adaptations of the invention, including such departures from the present disclosure as come within known or customary practice in the art to which the invention pertains, and as fall within the scope of the appended claims.

What is claimed is:

1. A system for calibrating light output by a light-emitting diode (LED), the system comprising:
 - 5 a support to which an LED to be calibrated may be positioned thereon;
 - a photosensor adjacent to the support for obtaining an output measurement generated by the LED;
 - a processor in communication with the photosensor and the LED, the processor configured to formulate a calibration value from an adjustment of the output measurement
10 against a reference value, such that during a subsequent generation of light output, the calibration value permits the subsequent light output to approximate an output accorded to the reference value; and
 - a memory mechanism in association with the LED, and on which the resulting value from the calibration may be stored.
- 15 2. A system as set forth in claim 1, wherein the support is can accommodate a fixture having multiple LEDs thereon.
3. A system as set forth in claim 1, further including an enclosed member
20 configured to encompass the support, the memory mechanism, and the photosensor, so as to block ambient light from therebetween and permit only measurement of the output from the LED.
4. A system as set forth in claim 3, wherein communication between the
25 processor and either of the LED or the photosensor can be implemented by one of a cable, wire, network, or a combination thereof.
5. A system as set forth in claim 3, wherein communication between the processor and either of the LED or the photosensor is by wireless means.

6. A system as set forth in claim 5, wherein the wireless means includes one of radio frequency (RF), infrared (IR), microwave, electromagnetic transmission, acoustic, Bluetooth, home RF or other wireless means.

5 7. A calibration device comprising:
a support to which an LED to be calibrated may be positioned thereon;
a photosensor adjacent to the support for obtaining an output measurement from the light output generated by the LED; and
a communication mechanism through which an output measurement from the
10 photosensor is communicated to a processor, which processor formulates a calibration value from an adjustment of the output measurement against a reference value, and through which the calibration value from the processor is communicated to the LED;
wherein the LED includes a memory mechanism on which the calibration value communicated from the processor may be stored.

15

8. A device as set forth in claim 7, wherein communication between the communication mechanism and the processor can be implemented by one of a cable, wire, network, or a combination thereof.

20 9. A device as set forth in claim 7, wherein the communication mechanism includes a transmitter and a receiver.

10. A device as set forth in claim 9, wherein communication between the processor and either of the transmitter and receiver is by wireless means.

25

11. A device as set forth in claim 10, wherein the wireless means includes one of radio frequency (RF), infrared (IR), microwave, electromagnetic transmission, acoustic, Bluetooth, home RF, or other wireless means.

30 12. A device as set forth in claim 7, further including a display on which parameters regarding light output from the LED may be provided to inform a user of status of the light output.

13. A device as set forth in claim 7, further including an interface to permit a user to vary light output parameters.

14. A device as set forth in claim 7, further including a second memory
5 mechanism for storing the output measurement from the photosensor, which output measurement can subsequently be communicated to the processor.

15. A device as set forth in claim 7, further including a processor for
formulating a calibration value from an adjustment of the output measurement against the
10 reference value, such that during a subsequent generation of light output, the calibration value permits the subsequent light output to approximate an output accorded to the reference value.

16. A calibration device comprising:
15 a housing;
an activation unit for inducing light output from an LED to be calibrated;
a photosensor at one end of the housing for obtaining an output measurement from the light output generated by the LED; and
a communication mechanism in the housing through which output measurement
20 from the photosensor is communicated to a processor, which processor formulates a calibration value from an adjustment of the output measurement against a reference value, and through which the calibration value from the processor can be received by the device and subsequently communicated to the LED.

25 17. A device as set forth in claim 16, wherein communication between the communication mechanism and either of the processor and LED can be implemented by one of a cable, wire, network, or a combination thereof.

18. A device as set forth in claim 16, wherein the communication mechanism
30 includes a transmitter and a receiver.

19. A device as set forth in claim 18, wherein communication between the processor and either of the transmitter and receiver is by wireless means.

20. A device as set forth in claim 19, wherein the wireless means includes one
5 of radio frequency (RF), infrared (IR), microwave, electromagnetic transmission, acoustic, Bluetooth, home RF, or other wireless means.

21. A device as set forth in claim 16, further including, on the housing, a display on which parameters regarding light output from the LED may be provided to
10 inform a user of status of the light output.

22. A device as set forth in claim 16, further including, on the housing, an interface to permit a user to vary light output parameters.

15 23. A device as set forth in claim 16, further including a memory mechanism for storing the output measurement from the photosensor, which output measurement can subsequently be communicated to the processor.

24. A device as set forth in claim 16, further including a processor for
20 formulating a calibration value from an adjustment of the output measurement against the reference value, such that during a subsequent generation of light output, the calibration value permits the subsequent light output to approximate an output accorded to the reference value.

25 25. An illumination device comprising:
a housing;
an LED illumination source positioned within the housing;
a photosensor adjacent to the illumination source for obtaining an output
measurement generated by the LED;

a processor within the housing and in communication with the photosensor for calibrating the output measurement received from the photosensor against a reference value, and with the LED for transmitting thereto a resulting calibration value from the processor; and

5 a memory mechanism coupled to the LED illumination source and on which the resulting calibration value from the processor may be stored.

26. A device as set forth in claim 25, further including a display on which parameters regarding light output from the LED may be provided to inform a user of
10 status of the light output.

27. A device as set forth in claim 25, further including an interface to permit a user to vary light output parameters.

15 28. A device as set forth in claim 25, further including a calibration activation mechanism to initiate calibration of the device.

29. A device as set forth in claim 25, wherein the LED illumination source includes a plurality of LEDs.
20

30. A method for calibrating light output by a light-emitting diode (LED), the method comprising:

- a) generating light output from the LED;
- b) obtaining an output measurement for the light output generated by the
25 LED;
- c) comparing the output measurement to a reference value;
- d) formulating a calibration value from an adjustment of the output measurement against the reference value, such that during a subsequent generation of light output, the calibration value permits the subsequent light output to approximate an
30 output accorded to the reference value.

31. A method as set forth in claim 30, further including storing the calibration value, such that upon the subsequent generation of light output, the stored calibration value may be accessed to permit the subsequent light output to approximate an output accorded to the reference value.

5

32. A method as set forth in claim 30, wherein the step of generating includes permitting the LED to emit light in an environment where there is an absence of ambient light.

10 33. A method as set forth in claim 30, wherein the step of comparing includes assigning a relative value to the output measurement, such that the relative value may be used in adjusting the output measurement.

15 34. A method as set forth in claim 30, wherein the step of formulating includes scaling the light output, such that the relative value approximates the reference value to permit generation of uniform light output by the LED.

35. A method as set forth in claim 30, wherein the step of formulating permits adjustment of intensity output by the LED.

20

36. A method as set forth in claim 30, wherein the step of formulating permits adjustment of color output by the LED.

25 37. A method as set forth in claim 36, wherein the calibration of color output by the LED can be used to provide a desired overall hue or whiteness in a multiple LED environment.

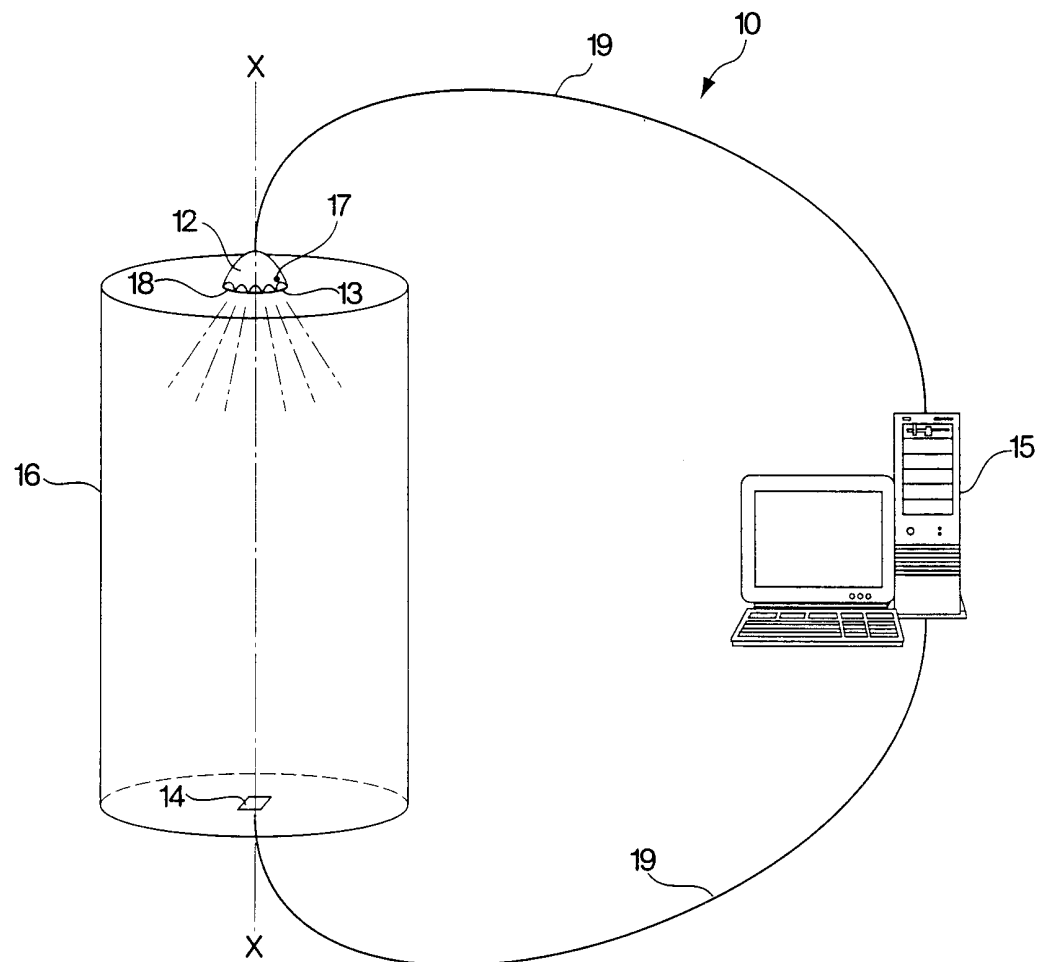

Fig. 1

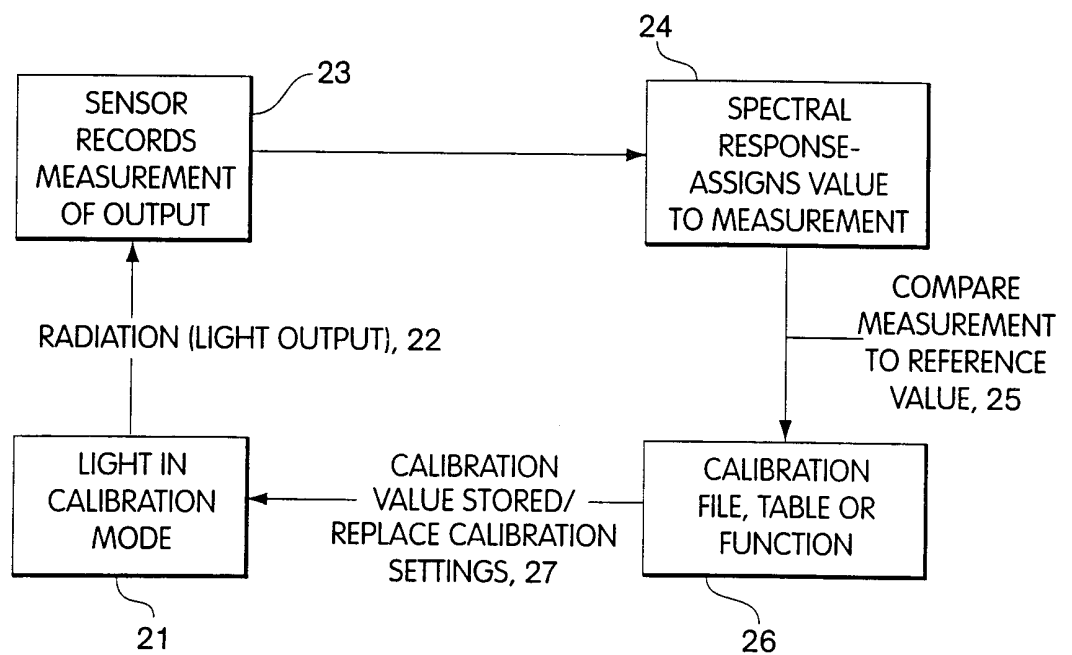
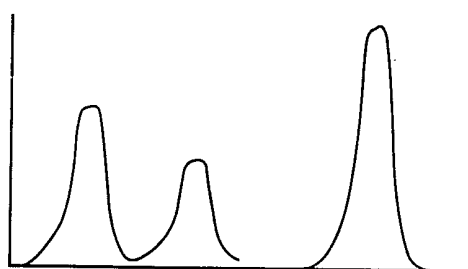
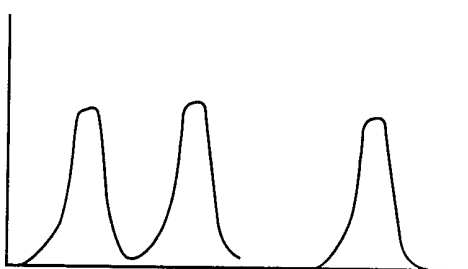

Fig. 2



BEFORE CALIBRATION COLOR
PEAKS CAN RANGE WIDELY

Fig. 3A



AFTER CALIBRATION COLOR PEAKS
CAN BE SCALED APPROPRIATELY

Fig. 3B

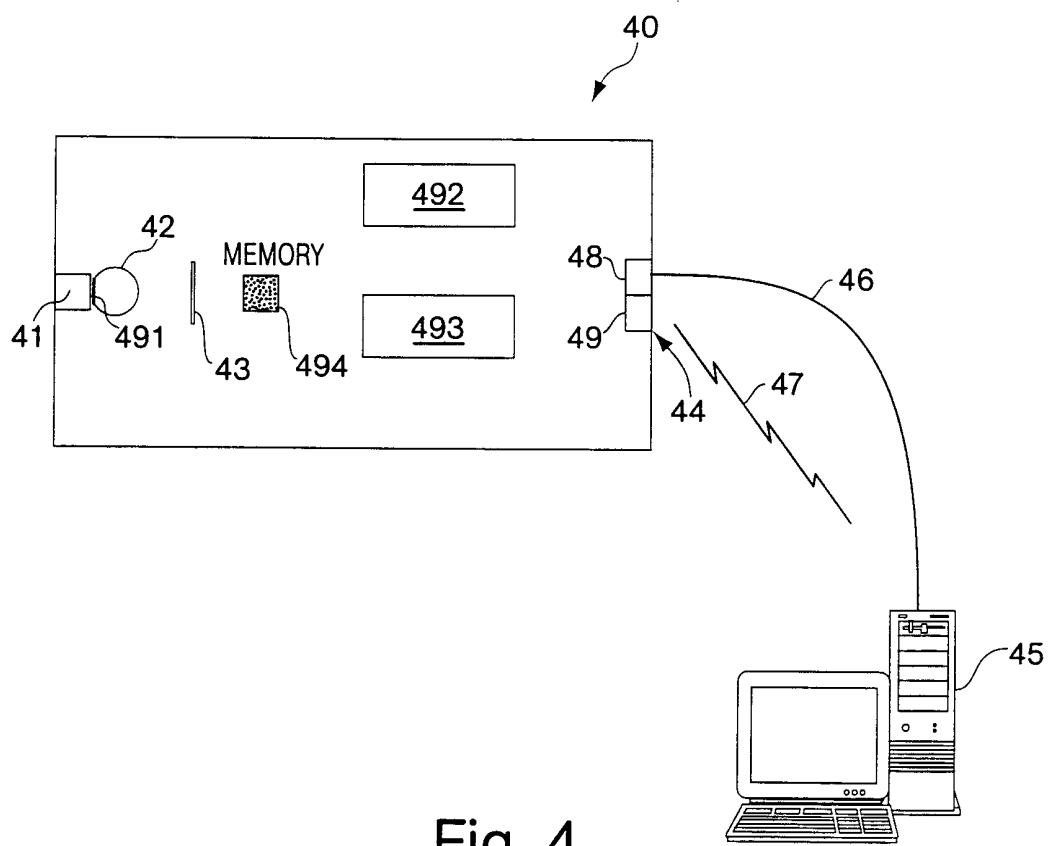

Fig. 4

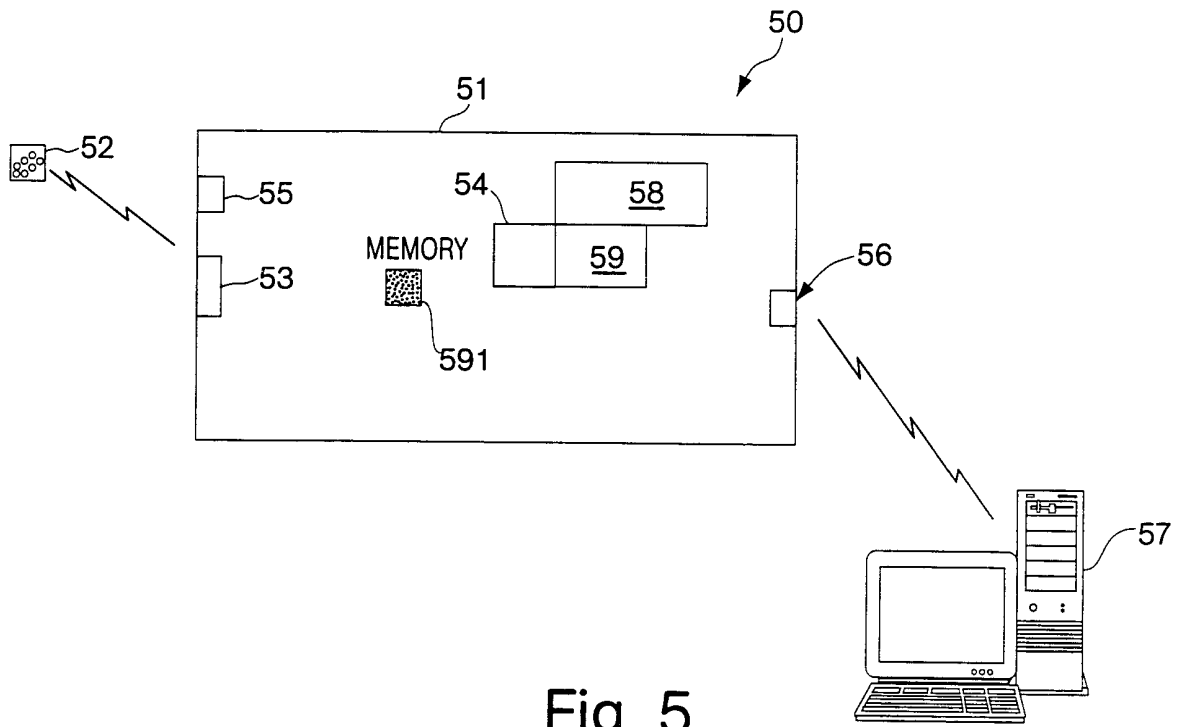

Fig. 5

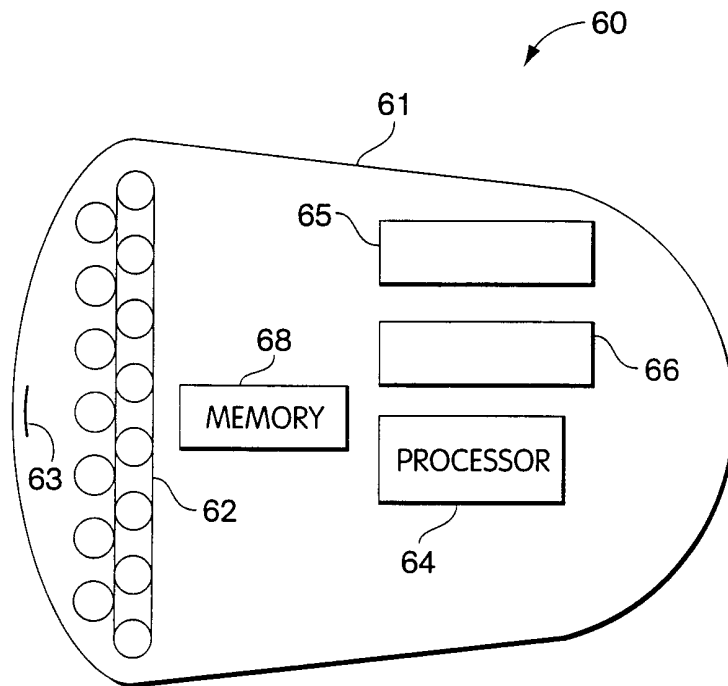

Fig. 6

INTERNATIONAL SEARCH REPORT

Int: ional Application No
PCT/US 00/26731

A. CLASSIFICATION OF SUBJECT MATTER
IPC 7 H05B33/08

According to International Patent Classification (IPC) or to both national classification and IPC

B. FIELDS SEARCHED

Minimum documentation searched (classification system followed by classification symbols)
IPC 7 H05B

Documentation searched other than minimum documentation to the extent that such documents are included in the fields searched

Electronic data base consulted during the international search (name of data base and, where practical, search terms used)

EPO-Internal, WPI Data, PAJ

C. DOCUMENTS CONSIDERED TO BE RELEVANT

| Category ° | Citation of document, with indication, where appropriate, of the relevant passages | Relevant to claim No. |
|------------|---|---|
| X | US 5 073 029 A (MAGNOTTI JR RALPH A ET AL) 17 December 1991 (1991-12-17) | 1-4, 7-9, 12, 13, 15-17, 21-27, 29-35 |
| Y | column 5, line 66 -column 12, line 15; figures 1-5 | 5, 6, 9-11, 14, 18-20, 28, 36, 37 |
| X | --- EP 0 497 431 A (SHARP KK) 5 August 1992 (1992-08-05) abstract; figure 8 --- | 1, 7, 16, 25, 30 |
| | -/-- | |

Further documents are listed in the continuation of box C.

Patent family members are listed in annex.

° Special categories of cited documents :

- *A* document defining the general state of the art which is not considered to be of particular relevance
- *E* earlier document but published on or after the international filing date
- *L* document which may throw doubts on priority claim(s) or which is cited to establish the publication date of another citation or other special reason (as specified)
- *O* document referring to an oral disclosure, use, exhibition or other means
- *P* document published prior to the international filing date but later than the priority date claimed

- *T* later document published after the international filing date or priority date and not in conflict with the application but cited to understand the principle or theory underlying the invention
- *X* document of particular relevance; the claimed invention cannot be considered novel or cannot be considered to involve an inventive step when the document is taken alone
- *Y* document of particular relevance; the claimed invention cannot be considered to involve an inventive step when the document is combined with one or more other such documents, such combination being obvious to a person skilled in the art.
- *&* document member of the same patent family

| | |
|--|---|
| Date of the actual completion of the international search <p style="text-align: center;">7 February 2001</p> | Date of mailing of the international search report <p style="text-align: center;">14/02/2001</p> |
| Name and mailing address of the ISA European Patent Office, P.B. 5818 Patentlaan 2 NL - 2280 HV Rijswijk Tel. (+31-70) 340-2040, Tx. 31 651 epo nl, Fax: (+31-70) 340-3016 | Authorized officer <p style="text-align: center;">Albertsson, E</p> |

INTERNATIONAL SEARCH REPORT

International Application No
PCT/US 00/26731

| C.(Continuation) DOCUMENTS CONSIDERED TO BE RELEVANT | | |
|--|---|---------------------------|
| Category ° | Citation of document, with indication, where appropriate, of the relevant passages | Relevant to claim No. |
| Y | GB 2 327 487 A (CHEN MEI YUN) 27 January 1999 (1999-01-27) page 7, line 2 -page 21, line 25; figures 1-7 ---- | 5,6, 9-11,14, 18-20 |
| Y | US 5 690 486 A (ZIGELBAUM SHELDON D) 25 November 1997 (1997-11-25) column 2, line 61 -column 5, line 25; figures 1-4 ---- | 28,36,37 |
| A | US 4 700 708 A (NEW JR WILLIAM ET AL) 20 October 1987 (1987-10-20) ---- | |
| A | US 5 956 158 A (PINZARRONE JOSEPH ET AL) 21 September 1999 (1999-09-21) ---- | |
| A | EP 0 413 441 A (DE LA RUE SYST) 20 February 1991 (1991-02-20) ---- | |
| A | US 5 859 658 A (HAMMOND THOMAS J) 12 January 1999 (1999-01-12) ---- | |
| A | EP 0 599 494 A (CANON INFORMATION SYST INC) 1 June 1994 (1994-06-01) ----- | |

INTERNATIONAL SEARCH REPORT

International Application No
PCT/US 00/26731

| Patent document cited in search report | Publication date | Patent family member(s) | Publication date |
|--|------------------|-------------------------|------------------|
| US 5073029 A | 17-12-1991 | AU 7313791 A | 03-09-1991 |
| | | EP 0515526 A | 02-12-1992 |
| | | JP 5504624 T | 15-07-1993 |
| | | WO 9112515 A | 22-08-1991 |
| EP 0497431 A | 05-08-1992 | JP 1302788 A | 06-12-1989 |
| | | JP 6007614 B | 26-01-1994 |
| | | JP 63254781 A | 21-10-1988 |
| | | JP 63254780 A | 21-10-1988 |
| | | JP 63254779 A | 21-10-1988 |
| | | JP 63254778 A | 21-10-1988 |
| | | EP 0497432 A | 05-08-1992 |
| | | DE 3854094 D | 03-08-1995 |
| | | DE 3854094 T | 25-01-1996 |
| | | DE 3854202 D | 24-08-1995 |
| | | DE 3854202 T | 25-01-1996 |
| | | DE 3879250 A | 22-04-1993 |
| | | DE 3879250 T | 24-06-1993 |
| | | EP 0287360 A | 19-10-1988 |
| US 4912714 A | 27-03-1990 | | |
| GB 2327487 A | 27-01-1999 | GB 2317675 A | 01-04-1998 |
| | | DE 19642801 A | 12-06-1997 |
| US 5690486 A | 25-11-1997 | NONE | |
| US 4700708 A | 20-10-1987 | US 4770179 A | 13-09-1988 |
| | | AT 51134 T | 15-04-1990 |
| | | AT 87809 T | 15-04-1993 |
| | | DE 3381344 D | 26-04-1990 |
| | | DE 3382674 A | 13-05-1993 |
| | | DE 3382674 T | 08-07-1993 |
| | | EP 0104772 A | 04-04-1984 |
| | | EP 0329196 A | 23-08-1989 |
| | | HK 161195 A | 20-10-1995 |
| | | JP 1831256 C | 15-03-1994 |
| | | JP 4250140 A | 07-09-1992 |
| | | JP 5047208 B | 16-07-1993 |
| | | JP 1790905 C | 29-09-1993 |
| | | JP 3055129 B | 22-08-1991 |
| JP 59064031 A | 11-04-1984 | | |
| US 4621643 A | 11-11-1986 | | |
| US 5956158 A | 21-09-1999 | AU 7099698 A | 22-10-1998 |
| | | CN 1256838 T | 14-06-2000 |
| | | EP 1013075 A | 28-06-2000 |
| | | WO 9844721 A | 08-10-1998 |
| EP 0413441 A | 20-02-1991 | US 5083063 A | 21-01-1992 |
| US 5859658 A | 12-01-1999 | JP 9123518 A | 13-05-1997 |
| EP 0599494 A | 01-06-1994 | US 5521708 A | 28-05-1996 |
| | | DE 69323045 D | 25-02-1999 |
| | | DE 69323045 T | 01-07-1999 |
| | | EP 0781983 A | 02-07-1997 |
| | | JP 6213727 A | 05-08-1994 |