

G. A. AMBLER.
DUPLIX NAILING MACHINE.

No. 525,066.

Patented Aug. 28, 1894.

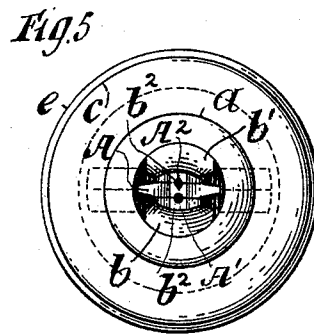
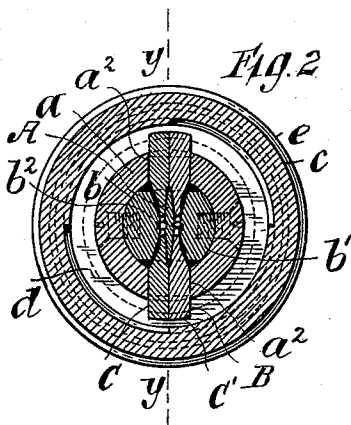
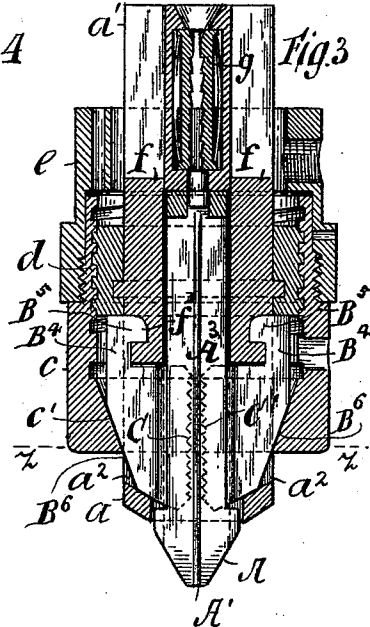
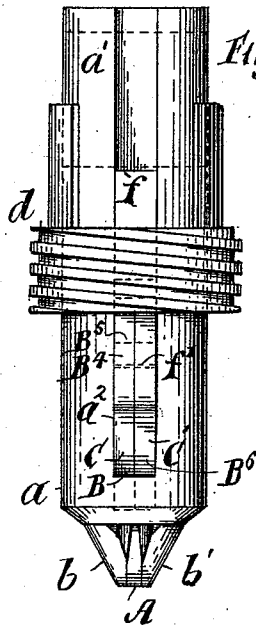
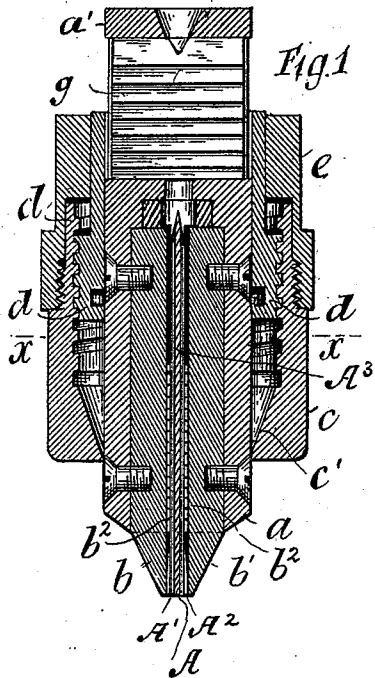

Witnesses

Geo. Wadman
E. Gatterer.

Inventor

George A. Ambler
Per Edw. E. Quincy
Atty.

G. A. AMBLER.
DUPLIX NAILING MACHINE.

No. 525,066.

Patented Aug. 28, 1894.

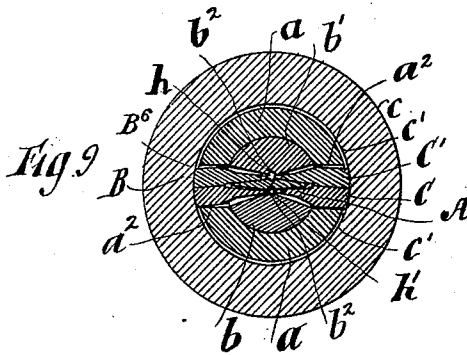
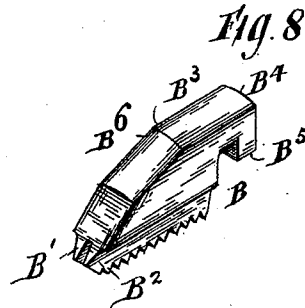
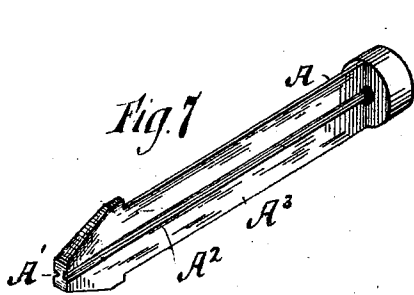
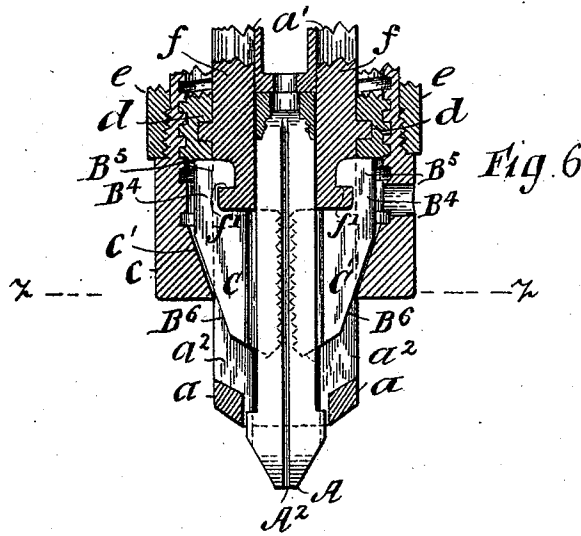

Witnesses
 Geo. Wadman
 E. Gatterer.

Inventor
 George A. Ambler
 Per Edu. E. Linnity
 Atty.

UNITED STATES PATENT OFFICE.

GEORGE A. AMBLER, OF NEWARK, NEW JERSEY, ASSIGNOR TO THE WIRE GRIP FASTENING COMPANY, OF CHICAGO, ILLINOIS.

DUPLEX NAILING-MACHINE.

SPECIFICATION forming part of Letters Patent No. 525,066, dated August 28, 1894.

Application filed December 4, 1893. Serial No. 492,724. (No model.)

To all whom it may concern:

Be it known that I, GEORGE A. AMBLER, of Newark, New Jersey, have invented certain Improvements in Duplex Nailing-Machines, of which the following is a specification.

This invention relates to the type of appliances for slugging the heels and taps and for uniting the soles and uppers of boots and shoes by means of fastenings composed of wire which is fed from a coil and forced into the stock to be united and is then cut off. Such appliances as heretofore constructed are adapted to insert only one such fastening at each actuation. By the present improvement 15 two such fastenings are simultaneously inserted, either in a continuous row or in two parallel rows, according as the stock is presented and fed.

The accompanying drawings, illustrating the so-called "working head" of a slugging machine converted into a duplex nailing device by the incorporation into it of the present improvements, are as follows:—

Figure 1 is a central longitudinal section. Fig. 2 is a transverse section taken through the plane indicated by the dotted line $x-x$ on Fig. 1. Fig. 3 is a longitudinal section taken through the plane indicated by the dotted line $y-y$ on Fig. 2. Fig. 4 is an elevation of the spindle, showing the screw threaded sleeve for controlling the position of the gripping sleeve. Fig. 5 is a lower end view. Fig. 6 is a longitudinal section of the lower portion of the head taken through the plane indicated by the line $y-y$ on Fig. 2, showing the grippers released from compression by the gripping sleeve. Fig. 7 is an isometrical perspective of the tongue which is interposed between the throat pieces. Fig. 8 is an isometrical perspective of one of the double grippers. Fig. 9 is a transverse section taken through the plane indicated by the line $z-z$ on Fig. 3, illustrating the mode of operation of double grippers, each composed of separate 45 pieces.

The drawings represent the principal portion of the so-called working head of the machine heretofore used for slugging the heels and taps and for uniting the soles and uppers of boots and shoes. The parts of the structure represented in the drawings, which are

old, are the hollow spindle, a ; the longitudinally slotted spindle extension a' ; the throat pieces, $b b'$, contained within the spindle; the gripping sleeve, c , which is commonly called the "slug grip ring;" the threaded sleeve, d , commonly called the "slug thread ring;" the sleeve, e , commonly called the "tappet ring;" the gripper carriers, f, f' , and the upper spring grippers, g , for preventing any upward movement of the wire during the return or upward movement of the grip ring. Each of the throat pieces is provided with the central longitudinal groove, b^2 . These two grooves have heretofore been employed as the guides for a single wire during the actuation of the device.

The present invention relates to the embodiment in the structure shown in the drawings of the features by which that structure is converted into a duplex nailing or fastening device, the said new features being as follows, viz: First, the tongue, A , which is interposed between the throat pieces, $b b'$, and which is provided upon its opposite sides with the central longitudinal grooves, A' and A^2 , to enable it to serve in conjunction with corresponding grooves, $b^2 b^2$, in the throat pieces to suitably guide the two separate wires h and h' , while they are being forced out of the spindle extension into the work. The lower end of the tongue, A , is thickened sufficiently to enable it to fill the space between the lower ends of the throat pieces $b b'$. The shank, A^2 , of the tongue is of less thickness and is chamfered on the opposite sides of its central longitudinal portion. The throat pieces, $b b'$, as heretofore constructed, have had their grooves shallow enough to leave portions of the wire upon its opposite sides exposed sufficiently to permit the employment of a pair of wire grippers, one on one side and the other on the other side of the wire, for the purpose of gripping the wire and forcing it forward into the work. These grippers have heretofore been commonly called "slug grippers," and have been composed of a steel blade having a serrated edge for engaging the wire, the said blade being formed integrally with a thicker back, adapted to make a sliding fit with the opposite side walls of either of the longitudinal slots, a^2 , in the spindle extension; the back of the grippers being longer than the serrated

blade and being provided with an inwardly projecting tongue adapting it for engagement with the instrumentality by which the grippers are moved longitudinally.

- 5 The second feature of the present invention consists in the employment of a double gripper, B, in place of each single gripper heretofore employed. The double gripper may consist of two parallel serrated blades, B' B², integral with the thick back, B³, the extension, B⁴, of which is provided with the usual tongue, B⁵, adapted to be seated in the usual cavities, f' f', formed in the exteriors of the gripper carriers, f, f. The double gripper, however, 15 instead of being formed of one piece, may be composed of two single grippers, C C', placed side by side, as indicated in Fig. 9. There is a slight advantage in making the double gripper in two parts, by reason of the fact that if 20 one set of grippers encounters a section of wire which is of slightly less than its normal thickness, while the other set is encountering a section of wire of full thickness, the effect of the compression of the hollow conical surface, c', of the slug grip ring, c, upon the inclined ends, B⁶ of that pair of the grippers engaging the thicker wire will be to force those grippers sidewise and thus drive the other pair of grippers engaging the smaller wire laterally against the conical surface c', with the necessarily resultant effect that the other pair of grippers will thereby be forced farther inward and made to firmly engage the section of wire which is of less than its normal thickness. 30
- 35 It will be perceived that the presence of two separate pairs of guiding grooves permits the device to be employed for simultaneously fas-

tening wires differing from each other in size or in the shapes of their cross sections, as, for example, one wire may be circular in cross section, while the other has in cross section the shape of a parallelogram.

What is claimed as the invention is—

1. In a working head for a duplex nailing machine the combination as herein described 45 of the spindle, spindle extension, two longitudinally grooved throat pieces and gripping and actuating devices, with a tongue interposed between said throat pieces and having upon its sides longitudinal grooves corresponding with the grooves in said throat pieces, as and for the purpose set forth. 50

2. In the working head of a duplex nailing machine the slug grip ring, tappet ring, spindle, spindle extension, two throat pieces provided with longitudinal grooves, a tongue interposed between said throat pieces and also provided with longitudinal grooves, in combination with double grippers for gripping two wires seated in said grooves and at each 60 actuation of said working head simultaneously forcing said wires into the stock to be united.

3. In a duplex nailing machine the combination of the throat pieces b and b', each provided with a longitudinal groove, b², with the tongue A, provided upon its opposite sides with the longitudinal grooves A' A², as and for the purpose set forth. 65

GEO. A. AMBLER.

Witnesses:

A. M. JONES,
E. GATTERER.