

INTERNATIONAL APPLICATION PUBLISHED UNDER THE PATENT COOPERATION TREATY (PCT)

(51) International Patent Classification ⁴ : F16K 15/20	A1	(11) International Publication Number: WO 87/ 05374 (43) International Publication Date: 11 September 1987 (11.09.87)
--	----	--

(21) International Application Number: PCT/IT87/00018 (22) International Filing Date: 3 March 1987 (03.03.87) (31) Priority Application Number: 21126 B/86 (32) Priority Date: 4 March 1986 (04.03.86) (33) Priority Country: IT	(81) Designated States: AT, AT (European patent), AU, BB, BE (European patent), BG, BJ (OAPI patent), BR, CF (OAPI patent), CG (OAPI patent), CH, CH (European patent), CM (OAPI patent), DE, DE (European patent), DK, FI, FR (European patent), GA (OAPI patent), GB, GB (European patent), HU, IT (European patent), JP, KP, KR, LK, LU, LU (European patent), MC, MG, ML (OAPI patent), MR (OAPI patent), MW, NL, NL (European patent), NO, RO, SD, SE, SE (European patent), SN (OAPI patent), SU, TD (OAPI patent), TG (OAPI patent), US.
--	---

(71) SECTION 34(4)(a) DIRECTION SEE FOLIO 8a
 NAME DIRECTED Bridge Products, Inc
2215 Sanders Road Northbrook Illinois, U.S.A.

rt.
 the limit for amending the
 in the event of the receipt

(74) Agent: DR. ING. A. RACHELI & C.; Viale San Michele del Carso, 4, I-20144 Milan (IT).

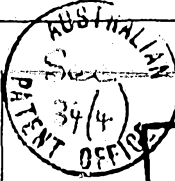

OCT 1987

This document contains the amendments made under Section 49 and is correct for printing.



(54) Title: IMPROVEMENTS IN VALVES AND IN THEIR AUTOMATIC ASSEMBLY

(57) Abstract

The proposed valve comprises valve body (10) which defines a through passageway (16) and a constriction (11) at an intermediate portion of the passageway (16), and a valve pin (20) slidably disposed in the passageway and carrying a sealing member (40) positioned to bear against a sealing surface (15) defined by the constriction (11) to seal the passageway (16), wherein the valve pin (20) defines a flange (23) adjacent the sealing member (40), said flange (23) having an external diameter (A) slightly larger than the minimum diameter (B) of the passageway (16) at the constriction (11) such that the flange (23) is sized to pass through the constriction (11) without destruction of the pin (20) or the valve body (10). The improvement foresees: means for defining a step (14) in the valve body (10) around the passageway (16) at the constriction adjacent to the sealing surface (15); and means for defining a shelf (23a) on the flange (23) shaped and positioned to engage the step (14) to prevent the pin (20) from being expelled out of the passageway (16).

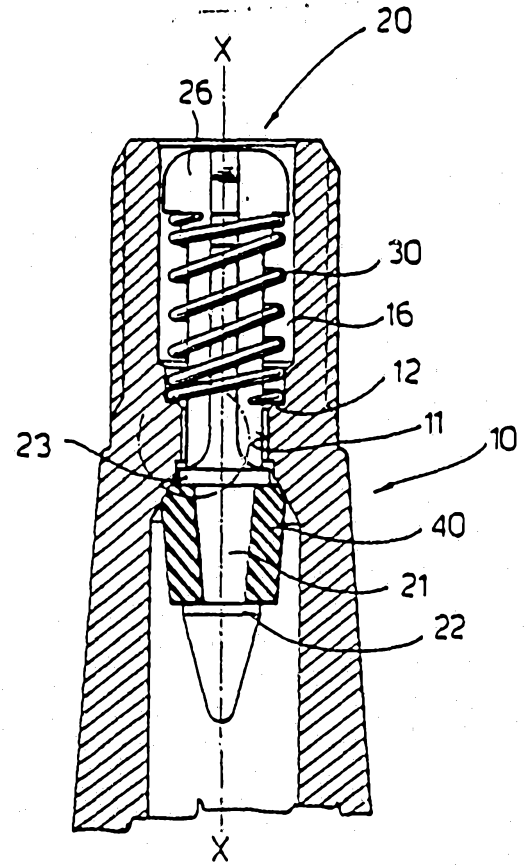

"IMPROVEMENTS IN VALVES AND IN THEIR AUTOMATIC ASSEMBLY"

This invention relates to valves of the type comprising a valve body which defines a through passageway and a constriction at an intermediate portion of the passageway, and a valve pin slideably disposed in the passageway and carrying a sealing member positioned to bear against a sealing surface defined by the constriction to seal the passageway, wherein the valve pin defines a flange adjacent the sealing member, said flange having an external diameter larger than the minimum diameter of the passageway at the constriction such that the flange is sized to pass through the constriction without destruction of the pin or valve body assembly. FR-A-2.340.493 describes a valve of the type comprising a valve body which defines an outside part, an inside part, a through passageway and a construction at an intermediate portion of the passageway, and a valve pin slideably disposed in the passageway and carrying a sealing member positioned to bear against a sealing surface defined by the constriction to seal the passageway, wherein at least one of the valve body and the valve pin is formed of a resilient material, and wherein the valve pin defines a flange (23) having an external diameter slightly larger than the minimum diameter of the passageway at the constriction such that the flange is sized such that temporary deformation of at least one of the valve body and the valve pin allows the flange to pass through the constriction without destruction of the pin or the valve body.

A high resistance to internal pressure, higher than that of the so far used valves, is necessary to meet the manufacturer's request of always higher working pressures.

Accordingly, there is disclosed herein a valve of the type comprising a valve body which defines a through passageway, a constriction at an intermediate position of the passageway, an inside part on one side of the constriction and an outside part on the outer side of the constriction, and a valve pin slideably disposed in the passageway and carrying a sealing member positioned to bear against a sealing surface provided in the inside part which is subjected to internal pressure to seal the passageway, wherein at least one of the valve body and the valve pin is formed of a resilient material, and wherein the valve pin defines a flange having an external diameter slightly larger than a minimum diameter of the passageway at the constriction sized such that temporary deformation of at least one of the valve body and the valve pin allows the flange to pass through the

KLN/18631



constriction without destruction of the pin or the valve body, comprising means for defining a step in the valve body around the passageway adjacent to the constriction wherein said means for defining said step is positioned on the same side of the constriction as the sealing surface; and means for defining a shelf on the flange shaped and positioned to engage the ~~step~~^{step} to prevent the pin from being expelled out of the constriction towards the outside part.

The valve body may also define a flared conic surface around the passageway on the side of the constriction opposite the step. Said flared conic surface may be inclined at an angle in the range of 27°-33° with respect to the axis; in particular the angle may be 30°.

The flared conic surface may also define an external diameter which is at least 5% greater than the external diameter of the flange.

The separation between the shelf and the step may be within the range of 0.2mm-1mm when the pressure differential across the sealing surface is zero.

Preferably at least one of the pin and the valve body is formed of a plastic material, such as acetyl co-polymer preferably having at least one of the following characteristics: to be black, shock resistant, not subject to oxidation, waterproof, not subject to photodegradation, and UV resistant.

The external diameter of the flange may be about 5%-9% greater than the minimum diameter of the passageway at the constriction .

The pin may also have a pointed internal end.

The sealing member may have at rest a shape of a cylindrical tube; in this case its internal diameter may be about 25% of its length. Moreover the pin may have a seat to receive the sealing member which has a frusto-conical shape.

The valve may also comprise a spring positioned around the valve pin to bear on the valve body to bias the flange towards the step and the sealing member as in the sealing surface.

All these characteristics improve the valve's performance and lower the costs at the same time.

KLN/18631



There is further disclosed herein a method for the assembly of a valve, having a valve body with a passageway, a constriction, an inside part on one side of the constriction and an outside part on the other side of the constriction, and a valve pin with a flange and carrying a sealing member wherein at least one of the valve body or the valve pin is resilient, the method comprising the following steps:

- a) the valve body is vertically arranged with its outside part upwards;
- b) a spring, if desired, is inserted in the body; the spring falls because of its weight and stops just above the constriction of the valve body when a shoulder is provided;
- c) the pin is inserted; during this operation the pointed end provided at the inside part of the pin guides the latter inside the passageway centering it;
- d) the insertion is continued temporarily deforming the valve body and forcing the flange through the constriction of the body;
- e) the pin is released and remains in position inside the valve body, a shelf defined by the flange of the pin abutting against a step defined by the valve body adjacent to the constriction thus preventing the expulsion of the pin;
- f) the sealing member is inserted from below while the pin is lowered, its insertion being facilitated by the pointed end of the pin.

The valve's field of use is greatly widened by the existence of the step and the shelf, the pin's bursting pressure being about 60% higher than that of a similar valve without step and shelf. Also the visible performance of the pin is greatly improved by the presence of the step and shelf; in fact in the known constriction the pin moves with respect to the body at higher pressures.

A preferred form of the present invention will now be described by way of example with reference to the accompanying drawings, wherein:

Fig. 1 is a view of the sectioned valve;

Fig. 2 is an enlarged view of the detail indicated in the outlined circle of Fig 1;

Figs. 3 to 7 show subsequent steps of the assembly.

As it is visible from Fig. 1, the valve comprises a limited number of parts: a body 10 defining a passageway 16, a pin 20, a sealing member 40 and, if desired, a spring 30.

KLN/18631



A constriction 11 is provided inside said valve body 10 substantially dividing said body in two: an outside part (shown above) and an inside part (shown below). The outside part provides a seat for spring 30 that leans against a shoulder 12; a flared conic surface 3 is provided in body 10 between shoulder 12 and constriction 11. The conic surface 13 is inclined with respect to valve axis X-X at an angle of between 27° and 33°; in particular the angle may be 30°.

The inside part of the constriction 11 is provided with a step 14. Starting from the step 14 and going towards the valve's inside a further conic surface 15 is provided against which the top part of the sealing member 40 leans. This surface will be called sealing surface 15.

The sealing member 40 at rest is a cylindrical tube having an internal diameter 41 (Fig. 6) which is about 25% of its length 42.

The pin 20 suitably shaped is housed in body 10. Said pin is provided with a head 26 to create a further abutment for spring 30. Pin 20 is also provided with a flange 23 forming a shelf 23a which faces step 14

KLN/18631



and abuts against it at the highest pressures. Deeper inside with respect to flange 23 pin 20 is provided with a truncated cone seat 21 for receiving the sealing member 40, and pointed end 22 forming a further abutment 24 for keeping sealing member 40 in place.

5 The flange 23's external diameter A (Fig. 2) is preferably about 5% to 9% bigger than the minimum diameter B of the body's constriction 11.

The separation D existing at rest with no pressure differential across the sealing surface 15 is preferably within the range of 0.2mm-1mm.

Moreover at rest the maximum external diameter C of the flared conic surface 13 is preferably at least 5% greater than the external diameter A of the flange 23.

For the valve's assembly the following steps are foreseen:

- a) valve body 10 is kept standing (Fig. 3);
- b) spring 30 is inserted in the passageway 16 (Fig. 4);
- c) pin 20 is inserted in the valve body inside spring 30 (Fig. 5);
- d) pin 20 is given a sharp knock so that flange 23 goes beyond

constriction 11;

e) pin 20 is released and remains inserted because shelf 23a abuts against step 14 (Fig. 6);

f) sealing member 40 is mounted from the bottom, while pin 20 is lowered (Fig. 7); sealing member 40 is seated on cone seat 21.

Pointed end 24 is particularly useful during the assembly for guiding pin 20 in body 10 and for facilitating the introduction of sealing member 40.

When pin 20 is positioned, the abutment existing between step 14 and shelf 23a avoids the expulsion due to the action of spring 30 when the sealing member 40 is not present.



The claims defining the invention are as follows:

1. A valve of the type comprising a valve body which defines a through passageway, a constriction at an intermediate position of the passageway, an inside part on one side of the constriction and an outside part on the outer side of the constriction, and a valve pin slideably disposed in the passageway and carrying a sealing member positioned to bear against a sealing surface provided in the inside part which is subjected to internal pressure to seal the passageway, wherein at least one of the valve body and the valve pin is formed of a resilient material, and wherein the valve pin defines a flange having an external diameter slightly larger than a minimum diameter of the passageway at the constriction sized such that temporary deformation of at least one of the valve body and the valve pin allows the flange to pass through the constriction without destruction of the pin or the valve body, comprising means for defining a step in the valve body around the passageway adjacent to the constriction wherein said means for defining said step is positioned on the same side of the constriction as the sealing surface; and means for defining a shelf on the flange shaped and positioned to engage the ~~step~~^{step} to prevent the pin from being expelled out of the constriction towards the outside part.

2. The valve of claim 1 wherein the passageway defines an axis, the step defines a first annular pin restraining surface oriented transverse to the axis and the shelf defines a second annular pin restraining surface oriented transverse to the axis and positioned to bear against the first pin restraining surface to prevent the pin from being expelled out of the passageway.

3. The valve of claim 1 wherein the valve body defines a flared conic surface around the passageway on the side of the constriction opposite the step.

4. The valve of claim 3 wherein the flared conic surface is inclined at an angle in the range of 27° - 33° with respect to the axis.

5. The valve of claim 4 wherein the angle is 30° .

6. The valve of claim 3 wherein the flared conic surface defines an external diameter which is at least 5% greater than the external diameter of the flange.

7. The valve of claim 1 wherein a separation between the shelf and the step is within a range of 0.2mm - 1mm when the pressure differential across the sealing surface is zero.

_KLN/18631



8. The valve of claim 1 wherein at least one of the pin and the valve body is formed of a plastic material.

9. The valve of claim 8 wherein the plastic material is an acetyl co-polymer preferably having at least one of the following characteristics: to be black, shock resistant, not subject to oxidation, waterproof, not subject to photodegradation, and UV resistant.

10. The valve of claim 1 wherein the external diameter of the flange is 5% - 9% greater than the minimum diameter of the passageway at the constriction.

11. The valve of claim 1 wherein the pin has a pointed internal end.

12. The valve of claim 1 wherein the sealing member has at rest a shape of a cylindrical tube.

13. The valve of claim 12 wherein the sealing member has an internal diameter which is about 35% of its length.

14. The valve of claim 12 wherein the pin has a seat to receive the sealing member which has a frusto-conical shape.

15. The valve of claim 1 further comprising a spring positioned around the valve pin to bear in the valve body to bias the flange towards the step and the sealing member against the sealing surface.

16. The valve of claim 1 wherein the sealing member is positioned and configured to remain in contact with the sealing surface when the shelf engages the step.

17. A valve substantially as hereinbefore described with reference to the accompanying drawings.

18. A method for the assembly of a valve, having a valve body with a passageway, a constriction, an inside part on one side of the constriction and an outside part on the other side of the constriction, and a valve pin with a flange and carrying a sealing member wherein at least one of the valve body or the valve pin is resilient, the method comprising the following steps:

a) the valve body is vertically arranged with its outside part upwards;

b) a spring is inserted in the body; the spring falls because of its weight and stops just above the constriction of the valve body when a shoulder is provided;

c) the pin is inserted from above; during this operation a pointed end provided at an inside part of the pin guides the latter inside the passageway centering it;

KLN/18631



d) the insertion is continued temporarily deforming the valve body and forcing the flange through the constriction of the body;

e) the pin is released and remains in position inside the valve body, a shelf defined by the flange of the pin abutting against a step defined by the valve body adjacent to the constriction on the inside part of the valve body on the same side of the constriction as the sealing surface thus preventing the expulsion of the pin;

f) the sealing member is inserted from below while the pin is lowered, its insertion being facilitated by the pointed end of the pin.

DATED this SEVENTH day of MARCH 1990
Bridgeport Brass S.p.A

Patent Attorneys for the Applicant
SPRUSON & FERGUSON

KLN/18631



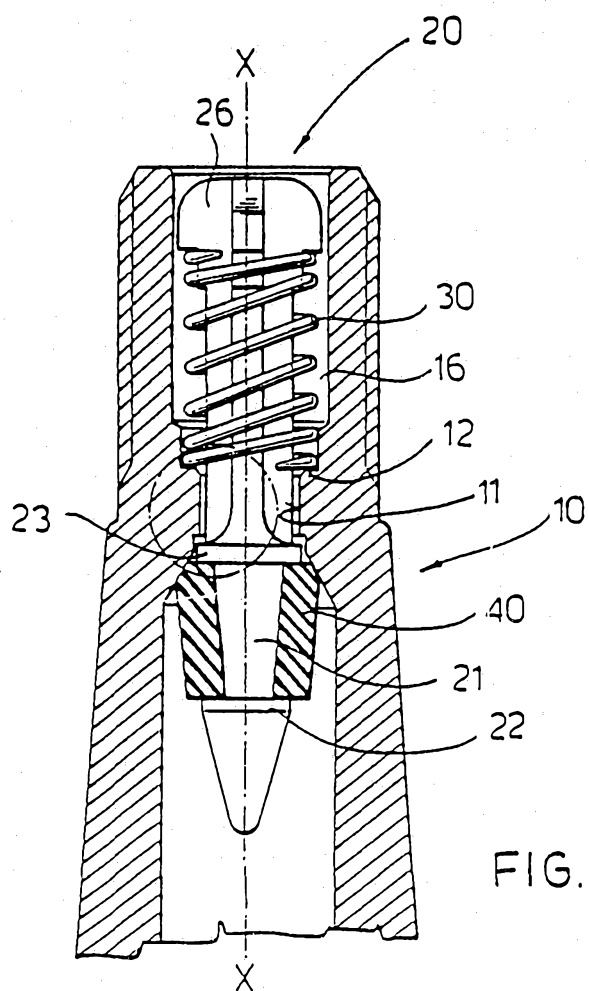

FIG. 1

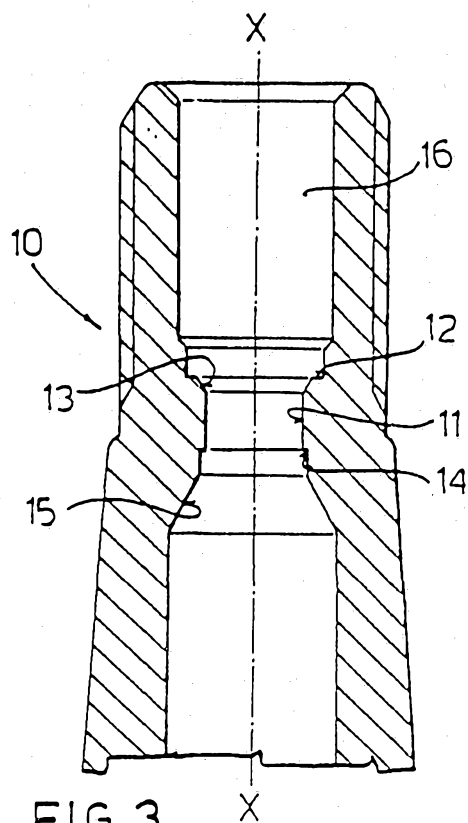

FIG. 3

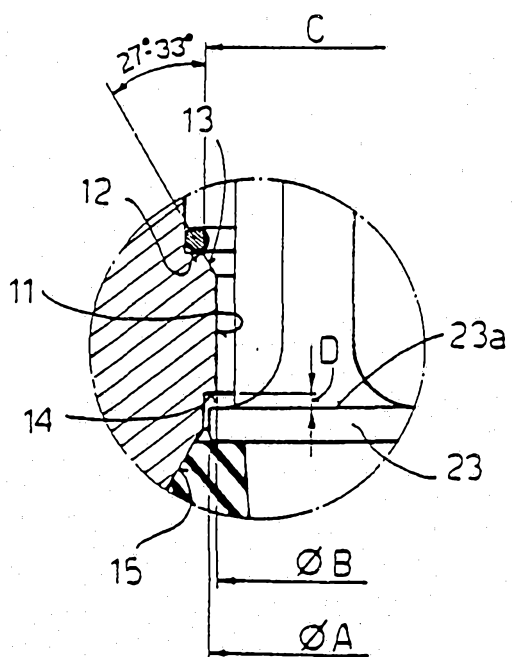

FIG. 2

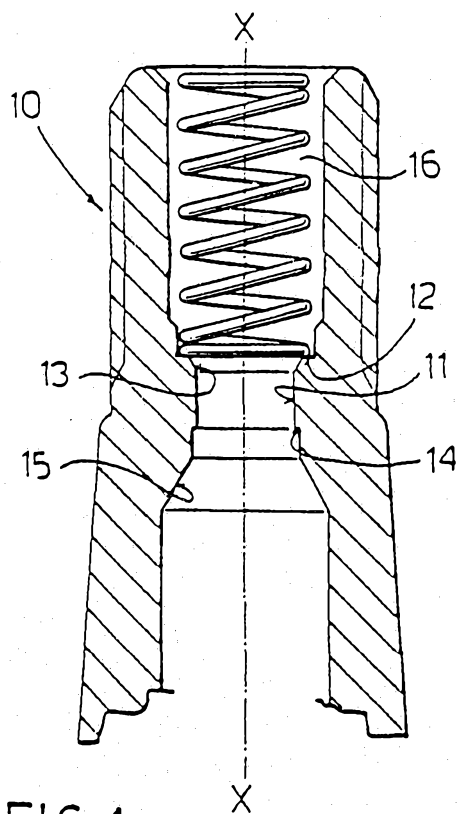

FIG. 4

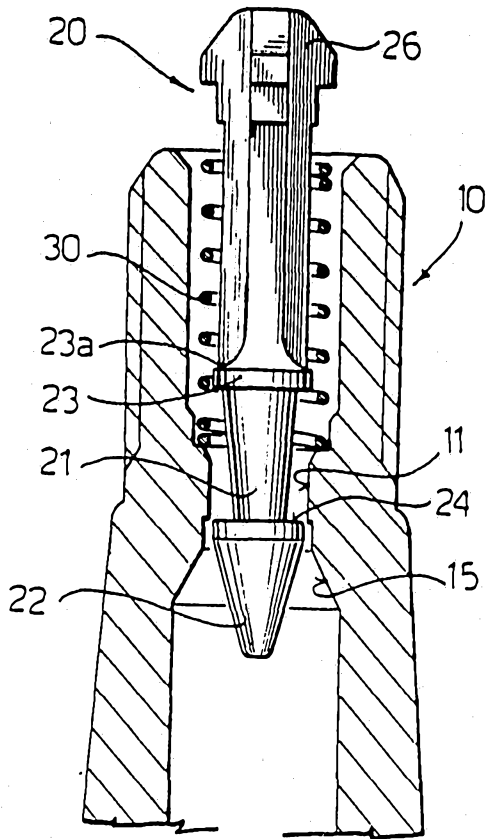

FIG. 5

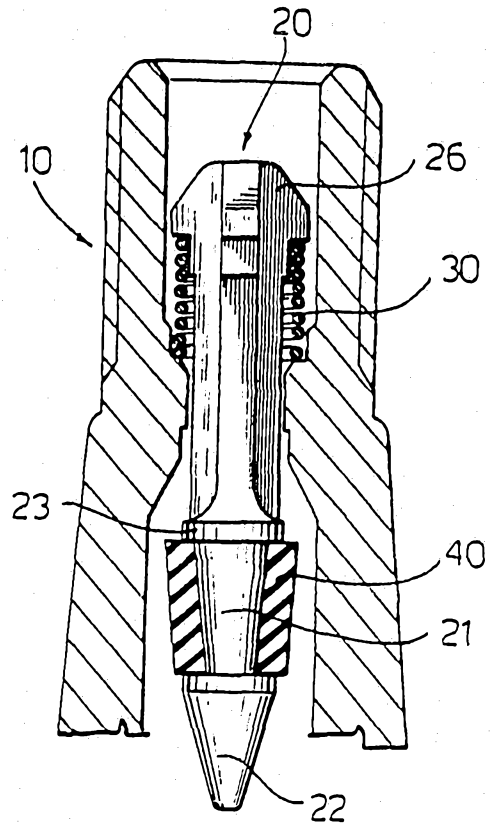

FIG. 7

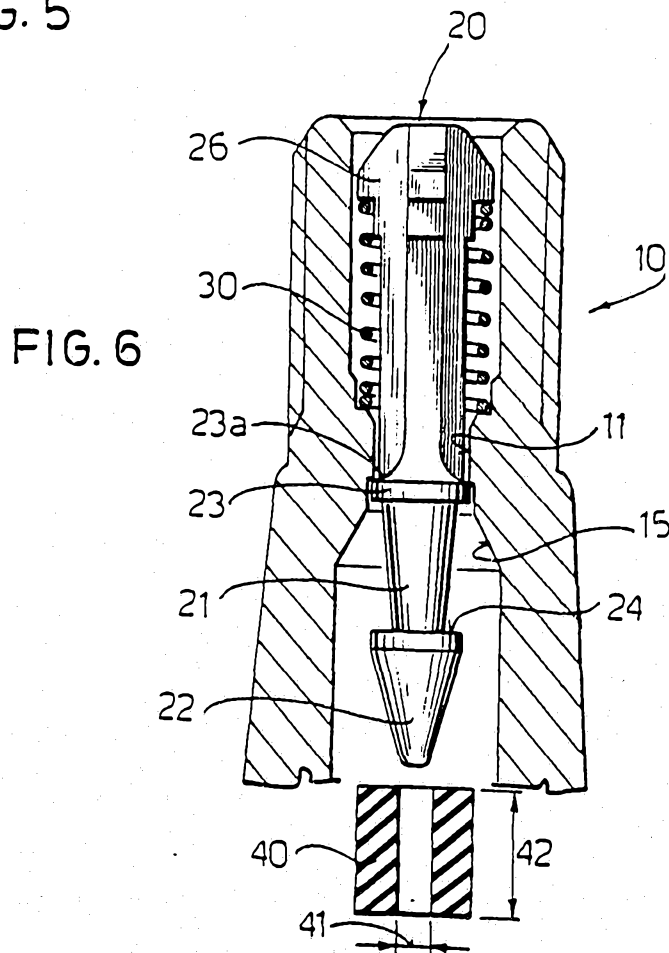
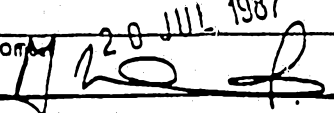

FIG. 6

INTERNATIONAL SEARCH REPORT

International Application No

PCT/IT 87/00018

I. CLASSIFICATION OF SUBJECT MATTER (if several classification symbols apply, indicate all) ⁶		
According to International Patent Classification (IPC) or to both National Classification and IPC		
IPC ⁴ : F 16 K 15/20		
II. FIELDS SEARCHED		
Minimum Documentation Searched ⁷		
Classification System	Classification Symbols	
IPC ⁴	F 16 K 15/00; B 60 C 29/00	
Documentation Searched other than Minimum Documentation to the Extent that such Documents are Included in the Fields Searched ⁸		
III. DOCUMENTS CONSIDERED TO BE RELEVANT ⁹		
Category ¹⁰	Citation of Document, ¹¹ with indication, where appropriate, of the relevant passages ¹²	Relevant to Claim No. ¹³
A	GB, A, 1044423 (EATON YALE & TOWNE INC.) 28 September 1966 see page 3, lines 118-127 --	1
A	BE, A, 672880 (PACIFIC INDUSTRIAL CO. LTD) 16 March 1966 --	
A	US, A, 3489166 (SCOVILL MFG. CO.) 13 January 1970 --	
A	FR, A, 2340493 (D. BERETTA) 2 September 1977 -----	
<p>¹⁰ Special categories of cited documents:</p> <p>"A" document defining the general state of the art which is not considered to be of particular relevance</p> <p>"E" earlier document but published on or after the international filing date</p> <p>"L" document which may throw doubts on priority claim(s) or which is cited to establish the publication date of another citation or other special reason (as specified)</p> <p>"O" document referring to an oral disclosure, use, exhibition or other means</p> <p>"P" document published prior to the international filing date but later than the priority date claimed</p> <p>"T" later document published after the international filing date or priority date and not in conflict with the application but cited to understand the principle or theory underlying the invention</p> <p>"X" document of particular relevance; the claimed invention cannot be considered novel or cannot be considered to involve an inventive step</p> <p>"Y" document of particular relevance; the claimed invention cannot be considered to involve an inventive step when the document is combined with one or more other such documents, such combination being obvious to a person skilled in the art.</p> <p>"Δ" document member of the same patent family</p>		
IV. CERTIFICATION		
Date of the Actual Completion of the International Search		Date of Mailing of this International Search Report
19th June 1987		20 JUL 1987
International Searching Authority		Signature of Authorized Officer
EUROPEAN PATENT OFFICE		M. VAN MOL 

ANNEX TO THE INTERNATIONAL SEARCH REPORT ON

INTERNATIONAL APPLICATION NO. PCT/IT 87/00018 (SA 16433)

This Annex lists the patent family members relating to the patent documents cited in the above-mentioned international search report. The members are as contained in the European Patent Office EDP file on 02/07/87

The European Patent Office is in no way liable for these particulars which are merely given for the purpose of information.

Patent document cited in search report	Publication date	Patent family member(s)	Publication date
GB-A- 1044423		None	
BE-A- 672880	16/03/66	None	
US-A- 3489166	13/01/70	None	
FR-A- 2340493	02/09/77	AT-B- 350922 GB-A- 1565463	25/06/79 23/04/80

For more details about this annex :
see Official Journal of the European Patent Office, No. 12/82