

1,000,074.

H. B. COLLIER.  
ELECTROMAGNETIC SWITCH.  
APPLICATION FILED SEPT. 15, 1909.

Patented Aug. 8, 1911.

2 SHEETS—SHEET 1.

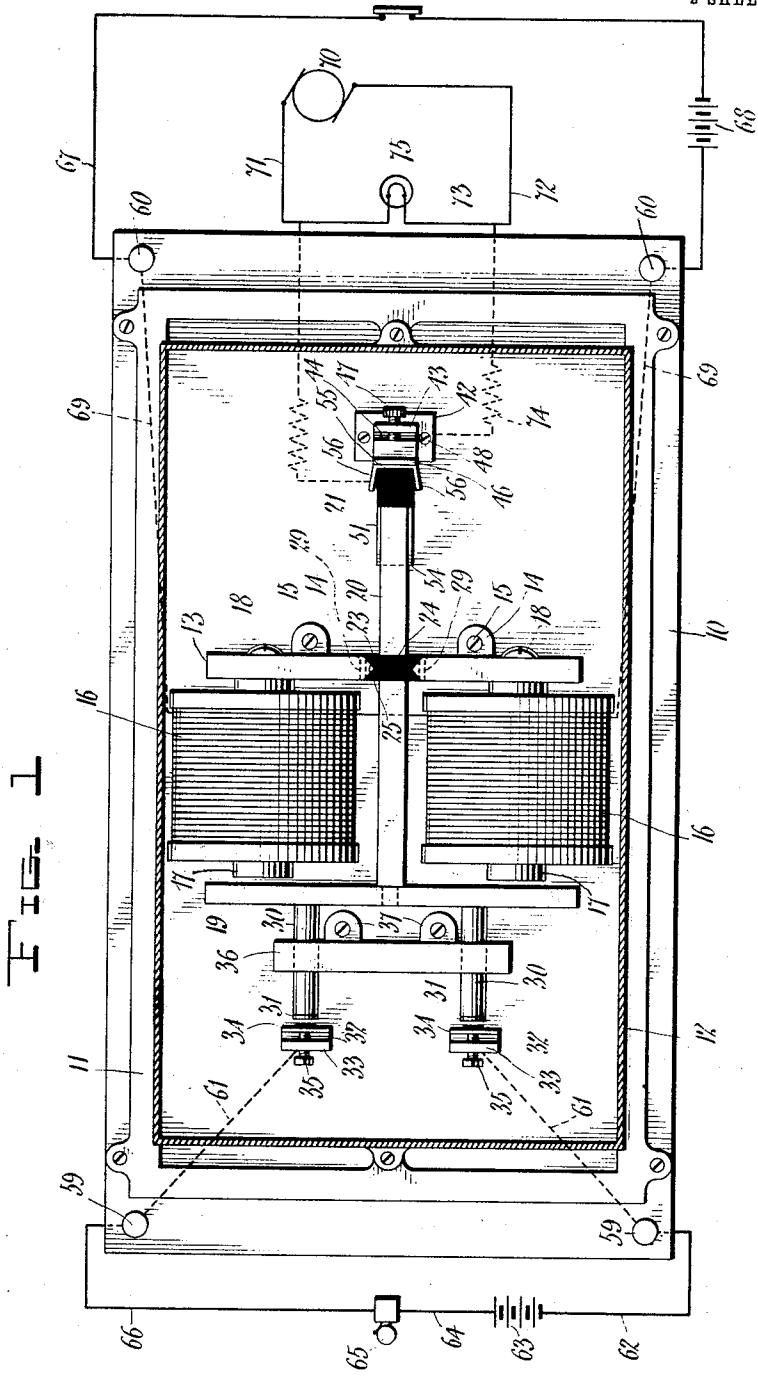

Witnesses  
*J. J. ...*  
*W. J. Miller*

Inventor  
*Henry B. Collier*

By *Hamilton Chandler*

Attorneys



# UNITED STATES PATENT OFFICE.

HENRY B. COLLIER, OF PRAIRIE GROVE, ARKANSAS.

## ELECTROMAGNETIC SWITCH.

1,000,074.

Specification of Letters Patent.

Patented Aug. 8, 1911.

Original application filed September 14, 1908, Serial No. 452,906. Divided and this application filed September 15, 1909. Serial No. 517,864.

To all whom it may concern:

Be it known that I, HENRY B. COLLIER, a citizen of the United States, residing at Prairie Grove, in the county of Washington, State of Arkansas, have invented certain new and useful Improvements in Electromagnetic Switches; and I do hereby declare the following to be a full, clear, and exact description of the invention, such as will enable others skilled in the art to which it appertains to make and use the same.

This invention relates to electromagnetic switches and has special reference to a form of switch adapted to be used with burglar alarms.

This application is a division of my prior application for automatic burglar alarms filed Sept. 14, 1908 and bearing the Serial No. 452,906.

One object of the invention is to improve the general construction of switches of this character.

Another object of the invention is to provide an electromagnetic switch of improved form for simultaneously opening one circuit and closing a second circuit, the operation of the switch to accomplish these results taking place upon the breaking of a third circuit.

With the above and other objects in view the invention consists in general of a casing wherein is mounted an electromagnetic switch of improved form including a pair of magnets arranged to be held in a normally closed circuit, a pair of normally closed contacts, and a pair of normally open contacts.

The invention further consists in certain novel details of construction and combinations of parts hereinafter fully described, illustrated in the accompanying drawings, and specifically set forth in the claims.

In the accompanying drawings, like characters of reference indicate like parts in the several views, and:—Figure 1 is a plan view with the casing sectioned, the view being partly diagrammatic to show a method of utilizing the switch. Fig. 2 is a central longitudinal section through the switch. Fig. 3 is a detail view of one of the plates for supporting the armature of the switch. Fig. 4 is a perspective view of the plate for supporting the armature of the switch. Fig. 5 is a detailed perspective view of the insulating bushing of the armature supporting plate, as illustrated in Fig. 4.

This electromagnetic switch comprises a base 10 upon which is secured a rectangular frame 11 having attached to it the lower edges of a casing 12 which is closed on all sides with the exception of its bottom. A plate 13 is formed at its lower edge with right-angularly extended ears 14 through which are passed suitable securing screws 15 which serve to hold the plate in upright position upon the base 10. Two electromagnets 16 are supported by the plate 13, the cores of these magnets being indicated by the numerals 17. These magnets are secured to the plate by means of suitable screws 18 which are threaded through the plate and into one end of the core of each magnet, the magnets extending at right angles of said plate. The armature for the two magnets is indicated at 19 and threaded at one end into the armature at a point midway of its ends is a stem 20 upon the opposite end of which is threaded a ferrule 21 of insulating material such as hard rubber. The plate 13 is formed in its upper edge with a notch 22 the side edges of which are beveled as indicated at 23, and inserted in this notch is a bearing 24, preferably of glass, although any other suitable insulating material may be used. The vertical or side edges of this bearing are formed with V-shaped grooves 25 which receive the beveled vertical edges 23 of the notch 22, the bearing being formed centrally with a bearing opening 26 which is polished smooth and through which the stem 20 carried by the armature 19 works. At each side edge and in one flat face, the bearing 24 is formed with a shallow notch or depression 27 and corresponding notches or countersinks 28 are formed in the corresponding face of the plate 13 at each edge of the notch 22 therein, there being screws 29 threaded into the plate 13 and engaging with their heads in the countersinks 28 and the notches 27 in the bearing. The bearing is in this manner securely held in place in the notches in the plate.

The armature 19 carries two contact points which are indicated by the numerals 30 and which are threaded into the armature, one of these contacts being located adjacent each end of said armature and projecting at right angles therefrom. These contacts are threaded into the armature upon the side opposite that from which the stem 20 projects, the said contact points being preferably pro-

vided at their extremities with platinum points 31 and being designed each to contact with one of a pair of contacts which are fixed upon the base 10 and which are interposed preferably in a bell signal circuit of a burglar alarm system.

The contacts just referred to are each composed of a block 32 formed with an upstanding integral rigid extension 33 and a second upstanding integral platinized extension 34, the latter extensions being resilient and being the ones against which the platinum points 31 of the contact pins 30 abut. In each of the rigid extensions 33 there is threaded an adjusting screw 35 and the end of this screw bears against the resilient extension of the contact member carrying the screw.

In order to guide the contacts 30 there is provided a plate 36 similar to the plate 13 and this plate is secured upon the base 10 by means of screws which are passed through ears 37 formed at the lower edge of the plate. This plate 36 has formed in each lateral edge a notch 38, said notches having their parallel or opposed edges beveled as indicated by the numeral 39. Bearings 40 similar to the bearings 24 are received, one in each of said notches 38, and are held therein by means of screws 41. Through the openings in these bearings 40 pass the contact points 30, it being understood that the armature 19 is supported for movement toward and from the cores of the electromagnets 16 by the plates 13 and 36 and their respective bearings.

At the opposite ends of the electromagnets 16 is arranged another pair of contacts. One of these contacts is composed of a body 42 formed with an upstanding integral rigid extension 43 and with a second upstanding extension 44 which extends substantially parallel with the extension 43 and is provided with a reduced portion as indicated at 45 so that this second extension is rendered yieldable and slightly resilient by this reduction. The upper end of the extension 44 is bent at an angle to form a contact surface 46 and an adjusting screw 47 is threaded through the extension 43 and bears against the extension 44 above the reduced portion 45. This adjusting screw serves as a means whereby the extension 44 may be adjusted to suit varying contact conditions. The contact just described is secured upon the base 10 by means of a binding screw 48 which serves also as a connection for a certain wire which will be presently described. The other contact of the pair comprises a block 49 between which and a washer 50 is disposed one end of a leaf spring 51. A binding screw 52 passes through the block. The end of the leaf spring and the washer 50 and this binding screw also extends through the base 10 and is provided

at the end which projects through the base with a nut 53. The leaf spring 51 is bowed as clearly indicated at 54, the concaved side of the spring being presented in the direction of the contact 42 previously described and the upper end or the extremity of the said spring being bent to extend vertically as at 55. This upper end is formed at each side with an ear 56, the insulated tip end 21 of the stem 20 being received between these ears and bearing against the vertically extended portion 55 of the spring. The block 49 is formed with a lateral horizontal extension 57 and threaded through this extension is an adjusting screw 58 which, at its lower end, bears against the contact spring adjacent the point of connection of the same with the binding screw 52 so that by adjusting this screw 58 the tension of the spring may be regulated. The tension of this spring normally causes the end 55 to move away from the contact 42.

At one end of the base 10 are mounted binding posts 59 and at the opposite end of said base are mounted binding posts 60. Wires 61 connect each of the binding posts 59 with one of the contacts 34 respectively and extending from one of the binding posts 59 is a wire 62 which, in the present instance, is connected to a battery 63 from which a wire 64 leads to a bell 65. From the bell 65 a wire 66 leads to the other binding post 59. From the binding posts 60 lead wires 67 which connect with a battery 68 and other wires 69 lead from these posts to the respective ends of the magnet winding. The magnets are thus in a normally closed circuit. In the present instance there is indicated at 70 a suitable source of electrical energy and wires 71 and 72 lead from this source of energy through relatively high resistant coils 74 to the contacts 49 and 42 respectively. At 73 is indicated a shunt including the lamp 75. The circuits here shown are typical of any preferred arrangement and are merely shown for the purpose of explaining the operation of the switch. In order to understand this operation let it be supposed that the bell circuit is open and the circuit from the source 70 is closed as indicated in Fig. 1. The circuit through the wires 69 and 67 is also to be supposed as closed. Now, if one of the wires 67 be broken the magnet will be deenergized. The result of this will be that the spring 51 will force the bar 20 forward and the contacts 30 will strike the contacts 34. This will close the circuit through the bell 65 as can be readily seen from reference to Fig. 1. At the same time the circuit through the wires 71 and 72 will be broken by the separation of the contacts 46 and 55. The result of this will be that the current will be forced to flow through the relatively high resistance in the circuit embracing the wire 73

and lamp 75 so that the lamp will be lighted, it being noted that on account of the low resistance through the contacts 49 and 42 the current will flow through these contacts so long as the circuit is unbroken and the lamp will remain dark. The breaking of the wire 67 thus actuates both a visual and a sonant signal.

It is obvious that minor changes may be made in the form and construction of this invention without departing from the material principles thereof. It is not therefore desired to confine the invention to the exact form herein shown and described, but it is wished to include all such as properly come within the scope of the appended claims.

Having thus described the invention, what is claimed as new, is:—

1. In a device of the kind described, a base, a paramagnetic plate extending upward from the base and provided with a notch formed centrally of its upper edge, an insulating bearing held in said notch, a pair of electromagnets having cores fixed to said plate, a bar slidably mounted in said bearing, an armature fixed to said bar in front of the poles of said magnet cores, a second paramagnetic plate fixed to said base in spaced relation to said magnets and parallel to the first mentioned plate, said second plate being provided with a pair of spaced notches, insulating bearings in said pair of notches, conductor bars fixed to said armature and slidably in said bearings of the second plate, contacts mounted on said base and extending into the paths of said conductor bars, a terminal of insulating material carried by the end of the first mentioned bar, a spring contact mounted on said base and constantly bearing against said insulating terminal to urge the armature away from the cores of the magnets, and a contact fixed to the base

and lying in the path traversed by the spring contact as the latter is moved under the influence of the attraction of the armature to said magnets when the current passes through the magnets. 45

2. In a device of the kind described, a base, a pair of plates extending upward from the base, a pair of magnets mounted between said plates, insulating bearings carried by said plates, a frame slidable in said insulating bearings and including a bar provided with an insulating terminal, an armature carried by said frame and lying adjacent the cores of said magnets, a spring contact mounted on said base in the path of said insulating terminal and constantly bearing against said terminal to urge the armature away from the cores, and a second contact fixed to the base and lying in the path traversed by the spring contact as the latter is moved under the influence of said magnets. 50 55 60 65

3. In a device of the character described the combination with a base, of a pair of magnets mounted on said base, a slidable frame including a bar provided with an insulated terminal, an armature carried by said frame and lying adjacent the cores of the magnets, a contact mounted on the base in the path of said insulated terminal and constantly bearing against said terminal to urge the armature from the cores of the magnets, a second contact lying in the path traversed by the first-named contact as the latter is moved under the influence of said magnets, and a suitable signal electrically connected to the contacts thus arranged. 70 75 80

In testimony whereof, I affix my signature, in presence of two witnesses.

HENRY B. COLLIER.

Witnesses:

ED. F. BAIN,  
J. W. EDMISTON.