

No. 826,083.

PATENTED JULY 17, 1906.

C. BARGAMIN.
MECHANIC'S FURNACE.
APPLICATION FILED NOV. 14, 1905.

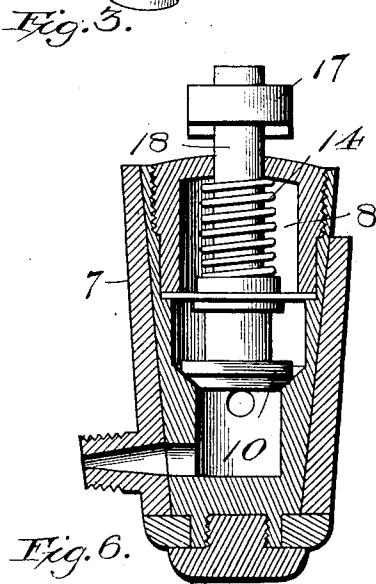
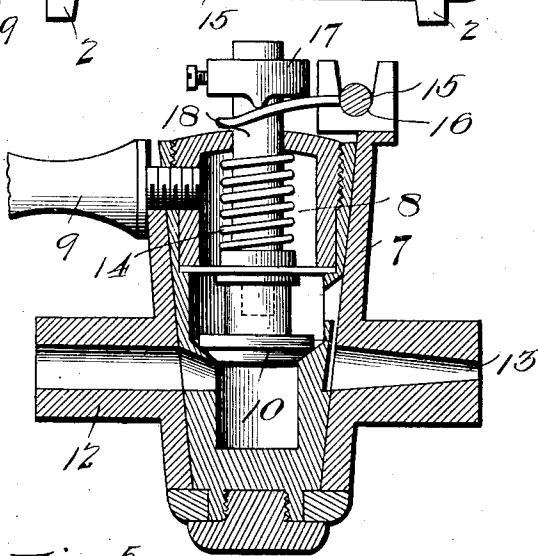
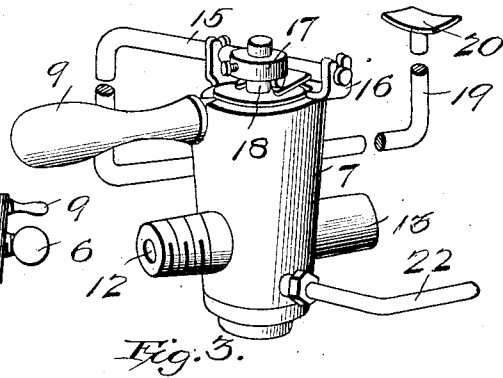
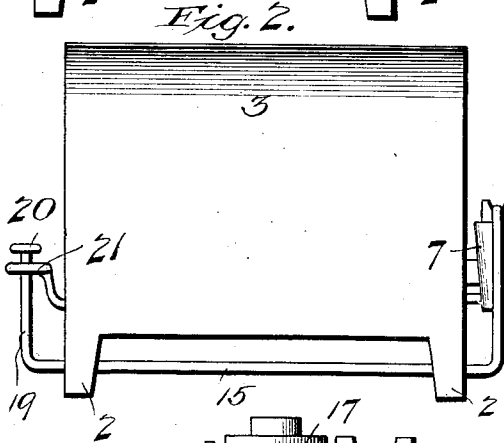
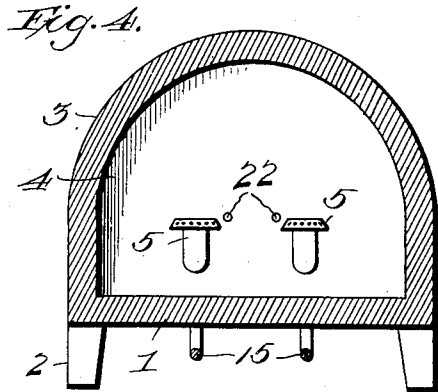
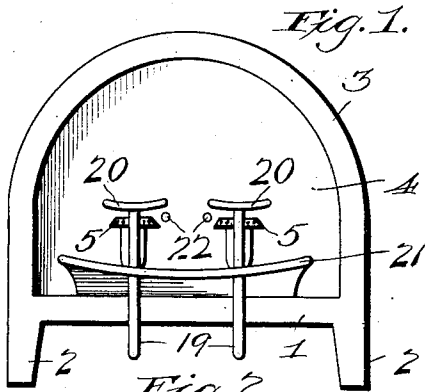

Fig. 5.

Fig. 6.

Inventor

CLIFFORD BARGAMIN

Witnesses
T. D. Mochamer
James F. Crown

By
Rejford M. Smith,
Attorney

UNITED STATES PATENT OFFICE.

CLIFFORD BARGAMIN, OF NEWPORT NEWS, VIRGINIA, ASSIGNOR TO THE NOVELTY MANUFACTURING CORPORATION, OF NEWPORT NEWS, VIRGINIA, A CORPORATION OF VIRGINIA.

MECHANIC'S FURNACE.

No. 826,083.

Specification of Letters Patent.

Patented July 17, 1906.

Application filed November 14, 1905. Serial No. 287,316.

To all whom it may concern:

Be it known that I, CLIFFORD BARGAMIN, a citizen of the United States, residing at Newport News, in the county of Warwick and State of Virginia, have invented a certain new and useful Mechanic's Furnace, of which the following is a specification, reference being had therein to the accompanying drawings.

This invention relates to mechanics' furnaces, the purpose of the invention being to provide a furnace particularly adapted to the requirements of mechanics, tailors, and laundrymen for the purpose of heating the irons used in their work and at the same time economizing in the use of gas or gasolene, the construction hereinafter described providing for automatically extinguishing the flame and cutting off the supply to the burner whenever an iron is removed from any particular burner, this being accomplished without disturbing the other burners, which continue in operation as long as the irons remain thereon. Furthermore, when the iron is returned to its position over the burner the burner is automatically relighted and remains burning as long as the iron is left thereon, no gas being thus consumed while the heated iron is being used.

With the above and other objects in view the invention consists in the novel construction, combination, and arrangement of parts hereinafter fully described, illustrated, and claimed.

In the accompanying drawings, Figure 1 is a front elevation of a mechanic's furnace embodying this invention. Fig. 2 is a side elevation of the same. Fig. 3 is a detail perspective view of the main supply-valve and its connections. Fig. 4 is a vertical cross-section through the furnace, showing two burners and an intervening pilot-tube. Fig. 5 is a diametrical section through the main valve. Fig. 6 is a similar section taken at right angles to Fig. 5.

The body of the furnace comprises a bottom 1, supported at a suitable elevation by means of legs 2 and having an inclosing hood or cover 3, arched over and above the bottom 1, the rear of said body being closed by means of an end plate 4, while the front end of the furnace is left open for the insertion of the irons or implements to be heated.

Within the furnace and arranged side by

side in a line extending transversely of the furnace are burners 5 5, to each of which leads a supply-pipe 6, in which at a suitable point and preferably at the rear end and outside of the furnace is a main supply-valve casing 7. Within the valve-casing is mounted a partially-rotatable valve 8, which may be turned on or off by means of a handle 9 for entirely cutting off the supply of gas by hand. The valve 8 is made hollow or provided with an internal chamber, which is divided into two compartments, the gas being admitted through the supply-pipe 12 into one compartment, whence it passes by the valve into the other compartment, and thence out through the connection 13, which leads to one of the burners.

The valve 10 is pressed toward its seat by means of a spring 14. The valve is lifted off its seat by means of an operating arm or lever 15, which is fulcrumed at 16 on the valve-casing 7 and coöperates by means of a tappet connection at 17 with the stem 18 of the secondary or automatic valve 10 for unseating said valve and allowing the gas to flow to the burner. The operating arm or lever 15 extends under the bottom of the furnace to the forward end thereof and upward in front of the furnace, being provided with an upstanding portion or extension 19, having at its upper end an implement rest or saddle 20, which is carried by and moves with the operating arm or lever 15 when said lever is rocked by any weight placed on the rest or saddle 20.

Located at the front of the furnace is a dished stationary saddle 21, forming an implement rest or support 21, which extends nearly, if not quite, across the end of the furnace and also constitutes a guide for the extensions 19 of the several operating arms or levers 15 of the burner-controlling valves, each extension 19 passing through an opening in the stationary rest 21 and being guided in its up-and-down movements thereby. The stationary implement-rest also forms a stop to arrest the downward movement of the saddles 21, sustains the weight imposed on said saddles, and thus relieves the strain which would otherwise be imposed on the levers 15.

In operation the implement—such, for example, as a soldering-iron—is placed upon the burner and the handle of the implement brought to rest on the saddle 20, through the

movement of which the valve of that particular burner is controlled. The weight of the handle depresses the saddle or rest 20 and through the medium of the arm or lever 15
 5 unseats the automatic secondary valve 10, and thereby allows the gas to pass to and supply the burner. Upon removing the implement rest 20 and operating-arm 15, being relieved of their weight, are uplifted or returned
 10 to their normal positions by the spring which operates on the valve 10, thus cutting off the flow of gas. Each burner operates independently of the other burner or burners, it being understood that any number of burners may
 15 be provided, according to the size and capacity of the furnace. When the implements are not in use, they may be placed so that the handles thereof lie on the stationary saddle or rest 21, and when the furnace is entirely
 20 out of use the gas may be cut off from the furnace by operating the handles 9.

22 designates a pilot-tube which leads from each valve-casing 7 to a point or points adjacent to the burner supplied thereby in the
 25 furnace. The pilot-tubes conduct a very small quantity of gas to points near the burners, and when the burners are cut off by the operation of the valves the gas from the pilot-burner is ignited and remains lighted so as to
 30 ignite the gas from the main burner when the latter is again turned on. It will thus be

seen that gas is used only when the iron or implement is over the burner, and that without any attention whatever on the part of the operator the gas at the main burner is extinguished automatically when the implement
 35 is removed, leaving only the pilot-burner in use, thus effecting a great saving in gas.

Having thus described the invention, I claim—

40 A mechanic's furnace comprising a heating-chamber, a burner therein, a burner-supply pipe, a valve controlling said pipe, an operating-arm connected with said valve and projecting in front of the furnace, a movable
 45 saddle carried by the projecting end of said arm and influenced by the weight of the implement-handle to automatically operate said valve, and a stationary member located outside of the heating-chamber and forming a
 50 combined guide and supporting stop through which the projecting end of the operating-arm works and also forming a rest for the implement when not in use.

In testimony whereof I have hereunto set
 55 my hand, at Newport News, Virginia, this 7th day of November, A. D. 1905.

CLIFFORD BARGAMIN.

Witnesses:

E. F. NICOLAI,
 H. C. IVY.