

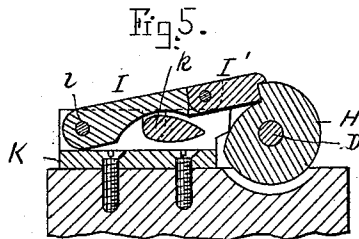

A. WILLIAMS.  
DUMPING SCOW.

No. 523,922.

Patented July 31, 1894.

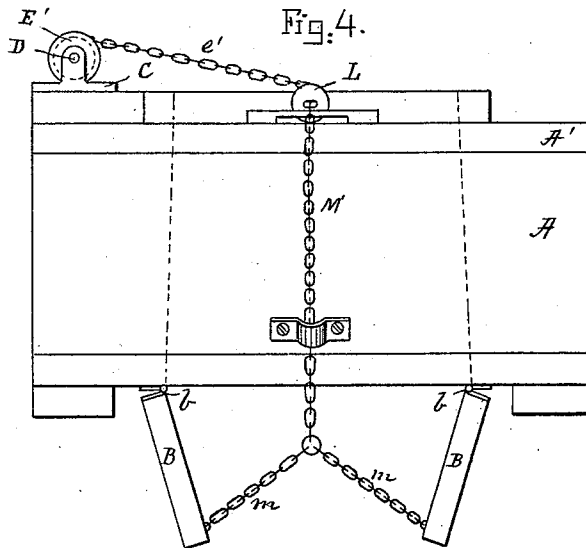
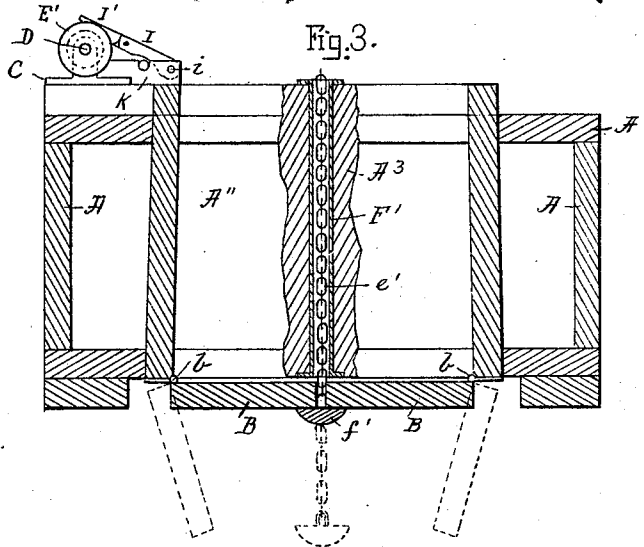

Witnesses.

*Lauritz N. Skoller.*  
*Kittie M. Hanson.*

Inventor

*Anthony Williams*  
*Alvan Judson*  
*per atty.*

# UNITED STATES PATENT OFFICE.

ANTHONY WILLIAMS, OF ROCKPORT, MASSACHUSETTS.

## DUMPING-SCOW.

SPECIFICATION forming part of Letters Patent No. 523,922, dated July 31, 1894.

Application filed January 26, 1894. Serial No. 498,122. (No model.)

*To all whom it may concern:*

Be it known that I, ANTHONY WILLIAMS, a citizen of the United States, and a resident of Rockport, in the county of Essex and State of Massachusetts, have invented new and useful Improvements in Dumping-Scows, of which the following, taken in connection with the accompanying drawings, is a specification.

This invention relates to improvements in dumping scows of the kind having a well room with hinged discharge doors at its bottom so as to cause the load to be automatically dumped when said hinged doors are released.

The invention is carried out as follows, reference being had to the accompanying drawings, wherein—

Figure 1, represents a top plan view of the improved dumping scow. Fig. 2, represents a central longitudinal section of the same on the line 2—2 shown in Fig. 1. Fig. 3, represents a cross section on the line 3—3 in Fig. 1 showing in dotted lines the doors open. Fig. 4, represents an end elevation showing the doors in open position; and Fig. 5, represents a detail cross section of the pawl and ratchet on line 5—5 shown in Fig. 1.

Similar letters refer to similar parts wherever they occur on the different parts of the drawings.

A represents the hollow scow body on which A' is the deck and A'' the well for receiving the load, which well is open from top to bottom and provided at its lower portion with a pair of floatable doors B B which are hinged at b b as is common in devices of this kind.

A<sup>3</sup> is a lateral partition in the well A'' and I wish to state that for very long or large scows I may prefer to use two or more such partitions according to the size of the scow and the load it is to carry; such partitions serving as supports for the middle chain guides through which the chains are run that serve to hold the doors in closed positions as will hereinafter be more fully described.

In suitable bearings C C C secured to the scow deck is journaled a shaft D to which are secured the chain wheels E E and E' as shown.

e e are chains secured to the wheels E E; and e' is a similar chain secured to the middle chain wheel E'. The chains e e are loosely guided through stationary vertical metal

pipes F F secured to the scow body a short distance beyond the ends of the well as shown in Figs. 1 and 2; such pipes going through said scow from deck to bottom board as shown.

To the lower end of the chains e e are secured metal buttons f f which when the chains are tightened are brought against the under side of the meeting portions of the hinged doors thus serving to hold the latter in a closed position at all times except during the discharge of the load from the well of the scow. The middle chain e' in a similar manner is loosely guided through the stationary vertical metal pipe F' secured in the partition A<sup>3</sup> and going vertically through the same as shown in Figs. 1, 2 and 3, and provided at its lower end with a metal button f' adapted to be brought against the under side of the middle portions of the doors B B thus serving as a middle support for holding the doors closed during the loading and transporting of the scow; such a middle support for the doors is very advantageous particularly if the doors are very long as it prevents their sagging in the middle particularly when designed for carrying a very heavy load as is frequently the case in dumping scows of this description.

The chains e e e' may be tightened wound upon their respective chain wheels E E E' by applying hand spikes or equivalent devices to a drum G secured to the shaft D as shown.

In bearings after the chains e e e' have been tightened sufficiently to cause their buttons f f f' to be brought against the under side of the meeting portions of the doors B B, the chain wheel shaft D is locked in position by means of a ratchet wheel H secured to said shaft and a preferably jointed pawl I I' adapted to engage a tooth on said ratchet wheel as shown in detail in Fig. 5; the said pawl is pivoted at i to a block K secured to the deck of the scow. In said block is located a pivoted pawl releasing dog k which when swung upward against the jointed pawl causes the latter to be released from engagement with the ratchet wheel H thus liberating the shaft D and its chains e e e' and allowing the doors B B to swing open during the discharge of the load from the well.

The releasing dog *k* may be attached by means of a handle or lever *k'* secured to it as shown in Fig. 1.

5 For the purpose of aiding in closing the doors after the load has been discharged I secure to the deck at each end thereof an elastic buffer preferably composed of a case or cylinder L containing a coiled spring *l* suitably connected to a rod *l'* passing loosely out  
10 through a perforation in the end of the said case L and connected to a chain M going over and outside of the deck end where it is guided in a suitable manner and connected to branch chains *m m* secured in their lower ends to the  
15 door ends as fully shown in Figs. 1, 2 and 4.

In releasing the supporting chains *eee'* the doors swing open allowing the load to be discharged and during such discharge the springs *ll* are compressed so as to cause the doors to  
20 commence their initial closing movement after the load has dropped out of the well, and are caused to continue their closing motion against the under side of the scow by their own buoyancy. After being thus closed the chains *eee'*  
25 are tightened as hereinabove described until their buttons *fff'* are brought to bear against the under side of said doors after which the chain wheel shaft is locked in position until it is again desired to discharge a new load and  
30 so on.

By having the locking buttons *fff'* attached to the ends of chains as described the locking device is always ready for use and is not liable to being damaged, broken or injured by  
35 coming in contact with objects at the bottom of the sea where the discharge is made, or

during the discharge of the load which is a common occurrence in dumping scows in which vertically movable rigid locking bars or bolts are employed.

Having thus fully described the nature, construction and operation of my invention, I wish to secure by Letters Patent and claim—

1. The hollow scow A having a well A'' open from top to bottom and having hinged doors B, B, arranged at the bottom of said well, in combination with a hoisting shaft D journaled in bearings at one side of the scow, and chains leading from said shaft through guides in the scow body and provided at their free ends with buttons bearing against the under side of said doors and serving as supports to hold the same closed, substantially as described.

2. The hollow scow A having a well open from top to bottom and having hinged doors B, B, arranged at the bottom of said well, and one or more partitions arranged transversely of the well in combination with a hoisting shaft D, chains leading from the shaft through guides in the scow body and said partitions, and buttons attached to the free ends of said chains and bearing against the under side of said doors and serving as supports to hold the same closed, substantially as described.

In testimony whereof I have signed my name to this specification, in the presence of two subscribing witnesses, on this 4th day of January, A. D. 1894.

ANTHONY WILLIAMS.

Witnesses:

ALBAN ANDRÉN,  
KITTEE M. HANSON.