

F. C. BRITT.  
BEAN PICKER.

APPLICATION FILED AUG. 25, 1910.

Patented July 11, 1911.

997,366.

3 SHEETS—SHEET 1.

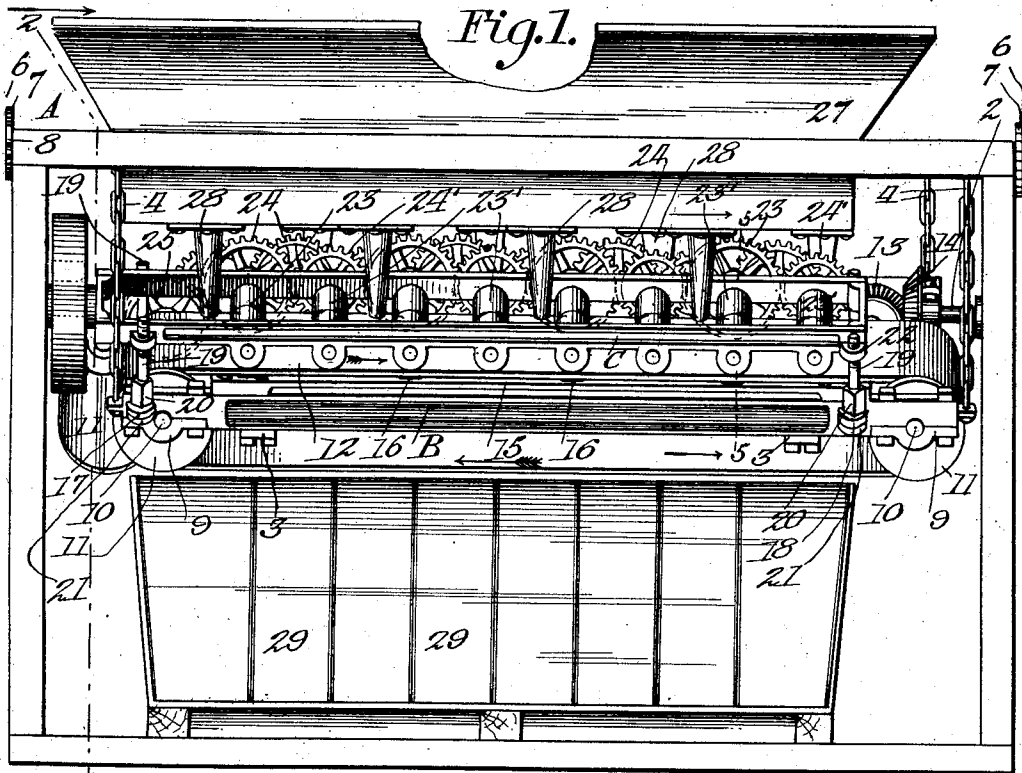
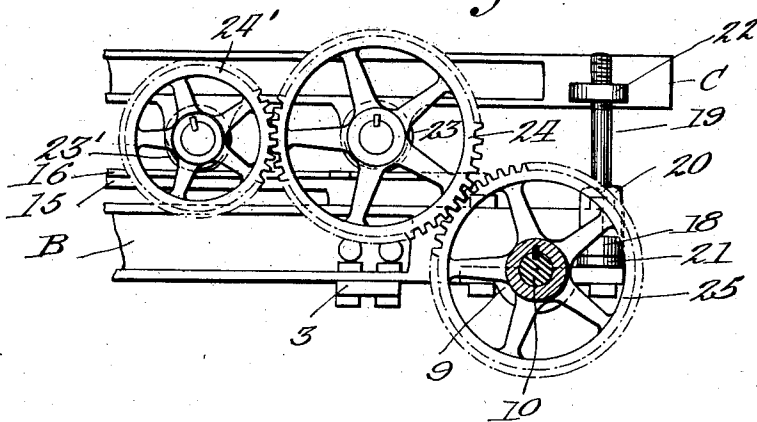

Fig. 4.



Inventor

Frederick C. Britt

By Victor J. Evans

Attorney

Witnesses

Phil E. Davies  
Wm. Bagger

F. C. BRITT.  
BEAN PICKER.

APPLICATION FILED AUG. 25, 1910.

Patented July 11, 1911.

3 SHEETS—SHEET 2.

997,366.

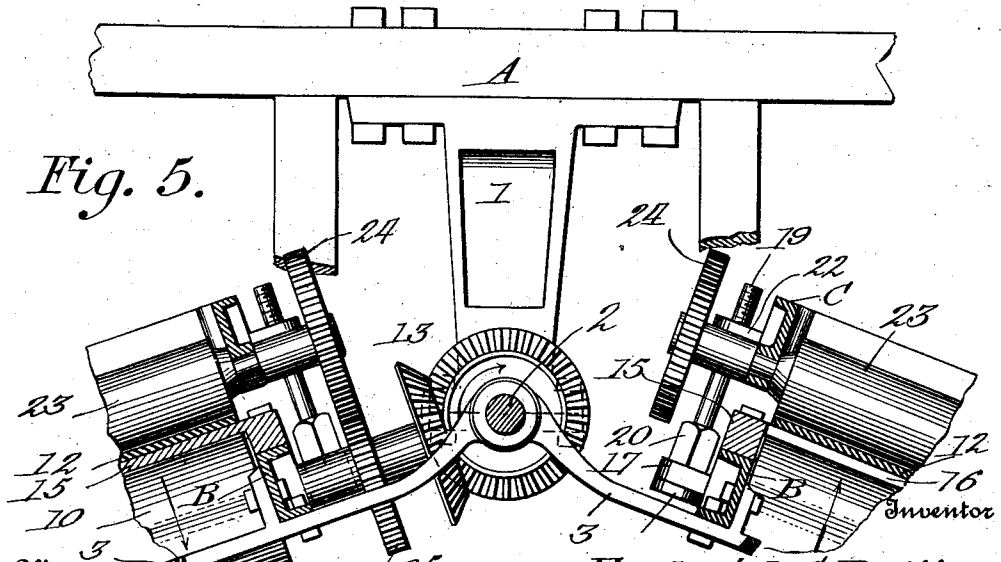
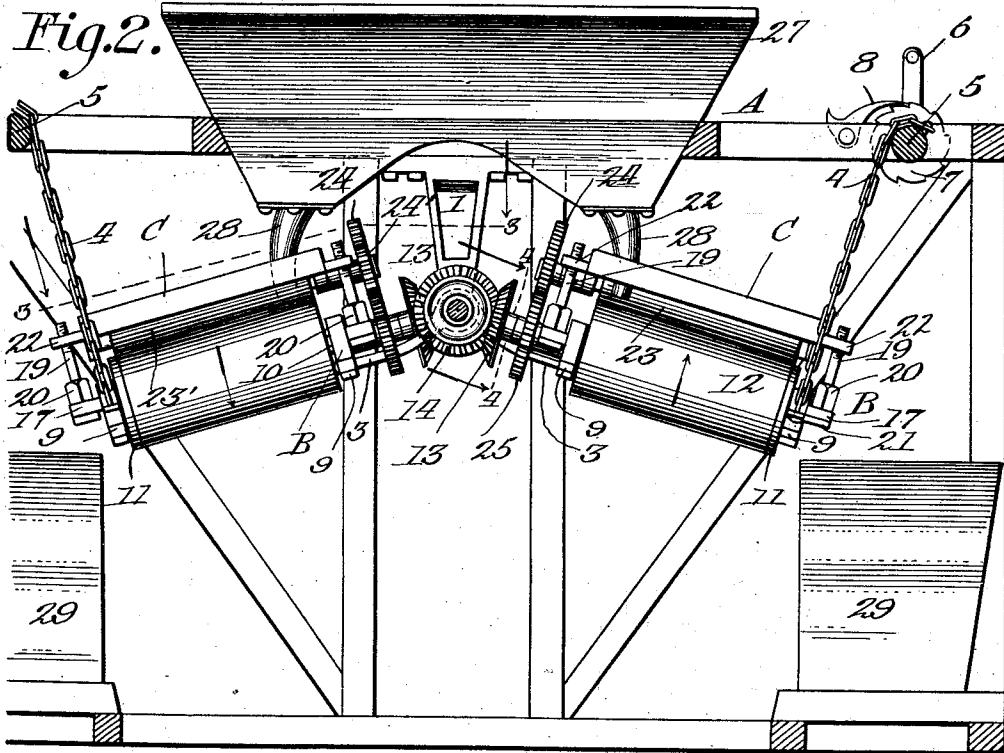

Witnesses  
*Phil E Barnes*  
*Wm Bagger*

Inventor  
*Frederick C. Britt*  
 By *Victor J. Evans*  
 Attorney

F. C. BRITT.  
BEAN PICKER.

APPLICATION FILED AUG. 25, 1910.

Patented July 11, 1911.

997,366.

3 SHEETS-SHEET 3.

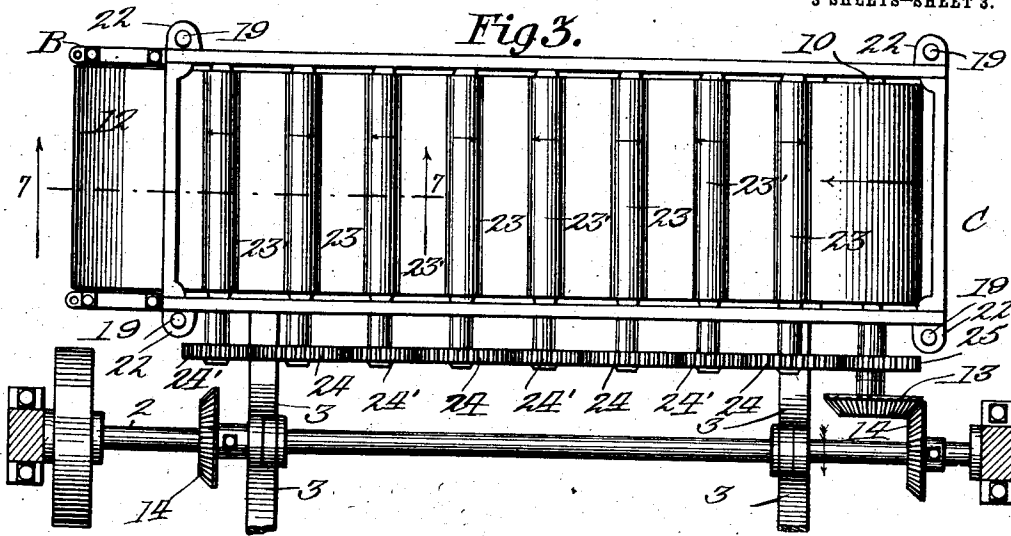

Fig. 6.

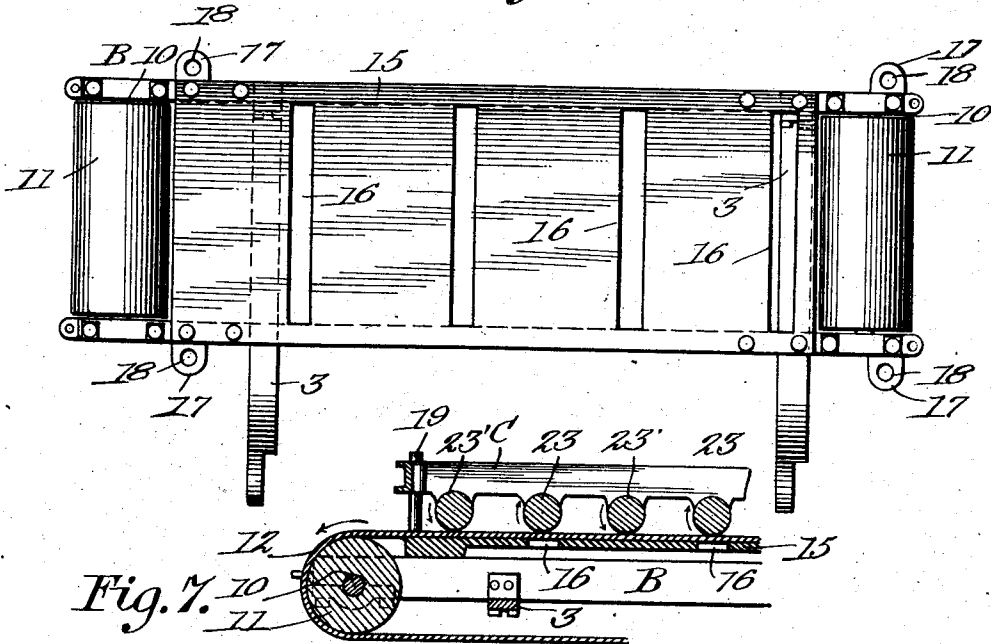

Fig. 7.

Witnesses  
*Phil E. Barnes*  
*Wm. Ragger*

Inventor  
*Frederick C. Britt*

By *Victor J. Evans*  
 Attorney

# UNITED STATES PATENT OFFICE.

FREDERICK C. BRITT, OF MIDDLEPORT, NEW YORK.

BEAN-PICKER.

997,366.

Specification of Letters Patent. Patented July 11, 1911.

Application filed August 25, 1910. Serial No. 578,833.

*To all whom it may concern:*

Be it known that I, FREDERICK C. BRITT, a citizen of the United States of America, residing at Middleport, in the county of Niagara and State of New York, have invented new and useful Improvements in Bean-Pickers, of which the following is a specification.

This invention relates to bean pickers, and it has for its object to produce a device of simple and inexpensive construction which may be efficiently utilized for the purpose of separating sound and good beans, peas and other grains from defective ones and from dirt, grit and the like.

With these and other ends in view, the invention consists in the improved construction and novel arrangement and combination of parts to be hereinafter fully described and claimed.

In the drawings,—Figure 1 is a side elevation of a machine constructed in accordance with the invention. Fig. 2 is a transverse sectional elevation taken on the plane indicated by the line 2—2 in Fig. 1. Fig. 3 is a sectional view taken on the line 3—3 in Fig. 2. Fig. 4 is a sectional detail view taken on the line 4—4 in Fig. 2. Fig. 5 is a sectional detail view taken on the line 5—5 in Fig. 1. Fig. 6 is a detail plan view of one of the apron carrying tables or supporting frames. Fig. 7 is a sectional detail view taken on the line 7—7 in Fig. 3.

Corresponding parts in the several figures are denoted by like characters of reference.

The improved machine includes a frame structure A which is provided with bearings 1 for a longitudinal main shaft 2 which is arranged about midway between the sides of the frame and which may be driven in any convenient well known manner from any suitable source of power. The main shaft affords a support upon which bracket members 3, 3 are pivotally mounted, two or more such bracket members extending from the main shaft toward each side of the machine and serving to support the picker frames B which may be bolted or otherwise suitably secured upon said brackets, there being one such frame at each side of the machine. The outer sides of the frames B are connected by flexible elements, such as chains 4 with suitably arranged drums or shafts 5 having cranks 6 whereby they may be rotated to wind the chains and equipped with ratchet wheels 7 engaged by pawls 8

for the purpose of securing the parts at the desired adjustment. It will thus be seen that each picker frame B may be supported securely in a tilted or inclined position, said picker frames being inclined downwardly from the center of the machine in an outward direction.

Each of the picker frames may consist of a suitably constructed frame of rectangular shape provided adjacent to the ends thereof with bearings 9 in which shafts 10 carrying rollers 11 are supported for rotation. The rollers 11, 11 at the ends of each frame serve to support an endless apron or carrier 12. One of the roller carrying shafts 10 of each frame is provided with a bevel gear 13 meshing with a bevel gear 14 upon the driven main shaft 2 from which motion will thus be transmitted to the endless apron or carrier at each side of the machine. The carriers may be driven in opposite directions, as indicated in the drawing, or both carriers may be driven in the same direction, if preferred, by a simple and obvious change in the arrangement of the transmission gears. It is also obvious that the transmission gears are to be so arranged as to remain in mesh at any adjustment of the pivotally supported frames with reference to the shaft about the axis of which said frames are adjustable.

Each of the rectangular frames B supports a platform or table 15 which serves to support the upper lead of the endless apron or carrier 12. This table or platform may be integral with the frame or it may be secured thereupon by bolts, rivets or in any other suitable and convenient manner. It is also desired to be understood that the precise form or structure of this supporting device may be modified in various ways, the object being to prevent the upper lead of the apron or carrier from sagging under pressure except at certain points where the said table or platform is provided with slots 16. The supporting device might be formed of a plurality of separate pieces suitably secured upon the frame and spaced apart to form the intermediate slots or openings 16 at the desired intervals.

Each of the frames B has been shown as provided with laterally extending lugs 17 which are apertured, as shown at 18, see Figs. 3 and 6, for the passage of supporting members consisting of bolts 19 which are

provided adjacent to the upper sides of said lugs with non-circular enlargements forming wrench seats 20 and adjacent to the undersides of the lugs with heads 21 serving to secure the bolts with reference to the lugs 18 in such a manner that said bolts may be rotated by applying a suitable tool, such as a wrench or spanner, to the seats 20. The threaded ends of the supporting bolts are extended through correspondingly threaded lugs 22 formed upon a frame C which is thus supported adjustably with reference to the frame B. Each frame C carries a plurality of rollers 23, 23' which are adapted to bear against the upper or outer face of one of the endless aprons or carriers 12, the degree of pressure being readily adjustable by means of the bolts or supporting members 19. The rollers 23, 23' are provided with intermeshing gears 24, 24', and it is desired to be understood that while the rollers are preferably of equal diameter, the gears 24 of alternate rollers 23 are larger than those of the intermediate rollers 23', thus causing the rollers 23' to be rotated not only at a greater speed, but in a reverse direction to the rollers 23. The latter, which are designated the picking rollers in contradistinction to the rollers 23' which are known as cleaning rollers, are arranged directly above the slots 16 in the belt supporting table, thus permitting the belt to sag slightly at the points beneath the rollers 23, while beneath the rollers 23' sagging is rendered impossible by the presence of the solid portion of the table or supporting member 15. The roller carrying shaft 10 associated with each frame is provided with a cog wheel 25 intermeshing with one of the gear wheels 24, thus transmitting motion to the entire set of rollers.

The beans that are to be cleaned are fed to the belts by means of a hopper 27 having spouts 28, said spouts being arranged to discharge beans upon each belt or carrier 12 adjacent to and in advance of each of the picking rollers 23. The receiving tanks or vessels 29 are suitably supported adjacent to the sides of the frame structure for the purpose of receiving material that is discharged over the lower edges of the belts or carriers. The receptacles or tanks are disposed adjacent to the spaces between the rollers, a separate receptacle being provided for each space. It is obvious that in view of the receptacles herein shown receiving chutes may be provided having connections whereby material will be conveyed to suitable bins provided for the reception of the sound beans and the refuse matter, respectively.

In the operation of the invention, the material to be cleaned and separated is discharged through the spouts 28 on to the

endless belt or carrier adjacent to the picking rollers which rotate in the direction of the lead of the belt adjacent to which they are supported. The sound beans, which are comparatively large, smooth and regular will not be engaged by the picking rollers, but will slide along the latter and be discharged over the edge of the belt. The refuse beans, which are relatively small and of irregular shape, as well as particles of grit, dirt, gravel and the like, will be engaged by the picking rollers and carried thereby between the rollers and the belt, which, as previously noted, is permitted to sag beneath the picking rollers, such refuse material being carried onward to the cleaning rollers which are rotated in a direction reverse to the movement of the belt, the refuse material being swept aside and off the belt by the action of said rollers. The picking rollers, moreover, are disposed opposite to the solid portions of the belt supporting table, so that sagging of the belt at these points will be impossible, rendering it impossible for any of the refuse material to be conveyed past the cleaning rollers.

This device, as will be seen from the foregoing description, is simple in construction and thoroughly effective for the purpose of picking or separating sound and high class beans from the inferior beans and refuse matter.

Having thus described the invention, what is claimed as new, is:—

1. In a machine of the character described, a frame having rollers supported for rotation adjacent to the ends thereof, a conveyer belt guided over the rollers, means for supporting the frame with the belt tilted transversely, means for driving the belt continuously in one direction, means for supporting some portions of the upper lead of the conveyer belt against sagging, picking rolls supported for rotation in juxtaposition to the unsupported parts of the belt, means for driving said picking rolls in the same direction as the belt, cleaning rolls supported for rotation in juxtaposition to the supported portions of the belt lead, and means for driving said cleaning rolls reversely to the movement of the belt.

2. In a machine of the character described, an endless driven belt supported in a tilted position, means for supporting portions of the upper lead of said belt against sagging, and picking and cleaning rolls supported in pairs adjacent to the unsupported and the supported portions of the belt, respectively, said rolls being provided with intermeshing pinions, whereby one set of rolls will be driven in the direction of the movement of the belt and the other set of rolls reversely to such movement.

3. In a machine of the character described, a frame, an endless driven conveyer belt sup-

ported thereby in a transversely tilted position, a suitably supported slotted table arranged to support the upper lead of the belt, a frame adjustably supported adjacent to the upper side of such upper lead, a plurality of rollers supported for rotation in said frame and having intermeshing gears whereby alternate rolls are reversely driven, the rolls opposed to the solid portions of the supporting table being driven reversely to the movement of the belt, means for feeding material upon the belt adjacent to its upper edge and in advance of the driven rolls supported opposite to the slotted portions of the table, and means for receiving the material discharged over the lower edge of the belt between the several rolls.

4. In a picking and separating machine, an endless flexible conveyer supported for movement in a transversely tilted position with reference to its direction of movement, means for supporting the top of said conveyer against sagging at various points which are suitably spaced apart, rotary picking means supported for rotation in the direction of movement of the conveyer adjacent to the unsupported portions of the top of the conveyer, and rotary cleaning means

supported for rotation reversely to the movement of the conveyer adjacent to the portions of such conveyer which are supported against sagging.

5. In a picking and separating device, a driven belt supported in a transversely tilted position, a table between the upper and lower leads of the belt and engaging the upper lead to support portions of the same against sagging, said table being provided with slots to permit the belt portions adjacent to such slots to sag, a frame supported above and adjacent to the upper lead of the belt, means for adjusting said frame toward and from the belt, rollers supported for rotation in said frame adjacent, respectively, to the unsupported and the supported portions of the upper belt lead, means for rotating the first mentioned rollers in the direction of the movement of the belt, and means for rotating the last mentioned rollers reversely to such movement.

In testimony whereof I affix my signature in presence of two witnesses.

FREDERICK C. BRITT.

Witnesses:

H. A. WILMOT,  
ARCHIE MULKIN.