



US00D415552S

**United States Patent** [19]  
**Malorni**

[11] **Patent Number: Des. 415,552**  
[45] **Date of Patent: \*\* Oct. 19, 1999**

[54] **FUNNEL FOR FILLING UP WINDSHIELD WASHER FLUID TANK**

[75] Inventor: **Michel Malorni**, St-Léonard, Canada

[73] Assignee: **9036-5305 Quebec Inc.**,  
St-Jean-sur-Richelieu, Canada

[\*\*] Term: **14 Years**

[21] Appl. No.: **29/089,281**

[22] Filed: **Jun. 11, 1998**

[30] **Foreign Application Priority Data**

Dec. 23, 1997 [CA] Canada ..... 1997-3287

[51] **LOC (6) Cl.** ..... **23-01**

[52] **U.S. Cl.** ..... **D23/200; D7/700**

[58] **Field of Search** ..... **D23/200; D7/700;**  
**D15/150; 141/297, 331-332, 339**

[56] **References Cited**

**U.S. PATENT DOCUMENTS**

- D. 309,241 7/1990 Ayyoubi et al. .... D7/700
- D. 309,558 7/1990 Ayyoubi et al. .... D7/700
- 1,242,453 10/1917 Lester .
- 1,510,631 10/1924 Nutry .
- 1,563,005 11/1925 Allee .

- 4,256,154 3/1981 Black .
- 4,286,634 9/1981 Wisner .
- 5,188,157 2/1993 Lee .
- 5,195,567 3/1993 Tyree ..... 141/297
- 5,360,039 11/1994 Verrilli .
- 5,445,196 8/1995 Tyree, Jr. .
- 5,535,793 7/1996 Tantre ..... 141/331
- 5,634,502 6/1997 Pierce ..... 141/331

*Primary Examiner*—Robin V. Taylor  
*Attorney, Agent, or Firm*—Robic

[57] **CLAIM**

The ornamental design for a funnel for filling up windshield washer fluid tank, as shown and described.

**DESCRIPTION**

FIG. 1 is a top front perspective view of a funnel for filling up windshield washer fluid tank, showing my new design, in closed position;  
 FIG. 2 is a top front perspective view thereof, in open position;  
 FIG. 3 is a top plan view thereof, in closed position;  
 FIG. 4 is a side elevational view thereof, in closed position;  
 FIG. 5 is a rear elevational view thereof, in closed position;  
 and,  
 FIG. 6 is a bottom plan view thereof.

**1 Claim, 4 Drawing Sheets**

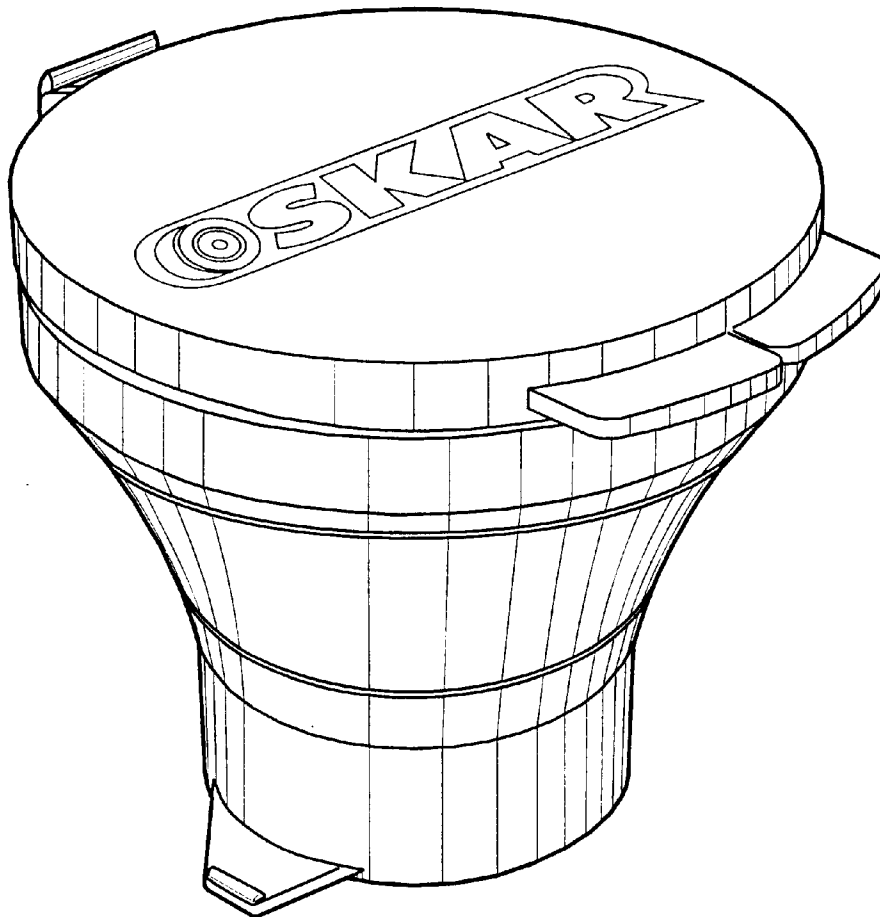

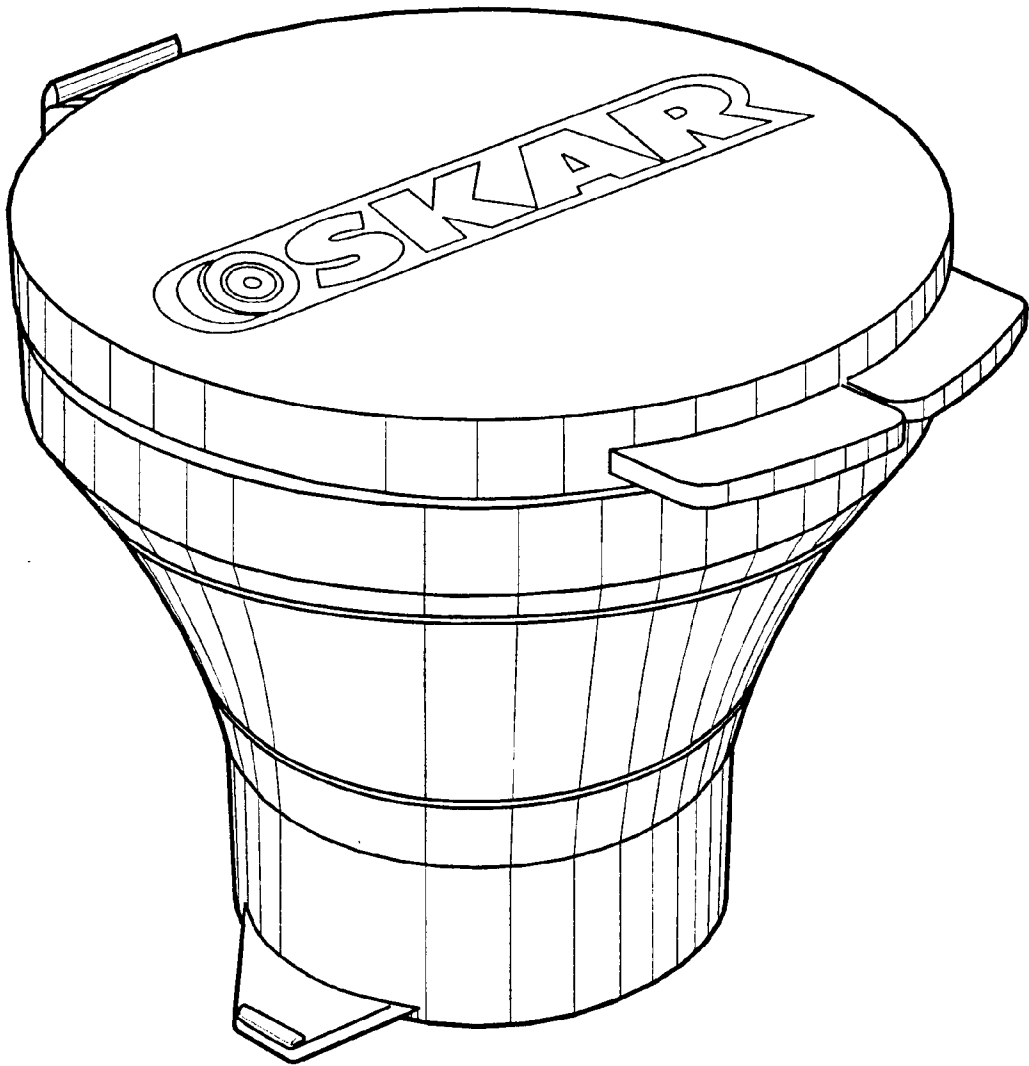

FIG. 1

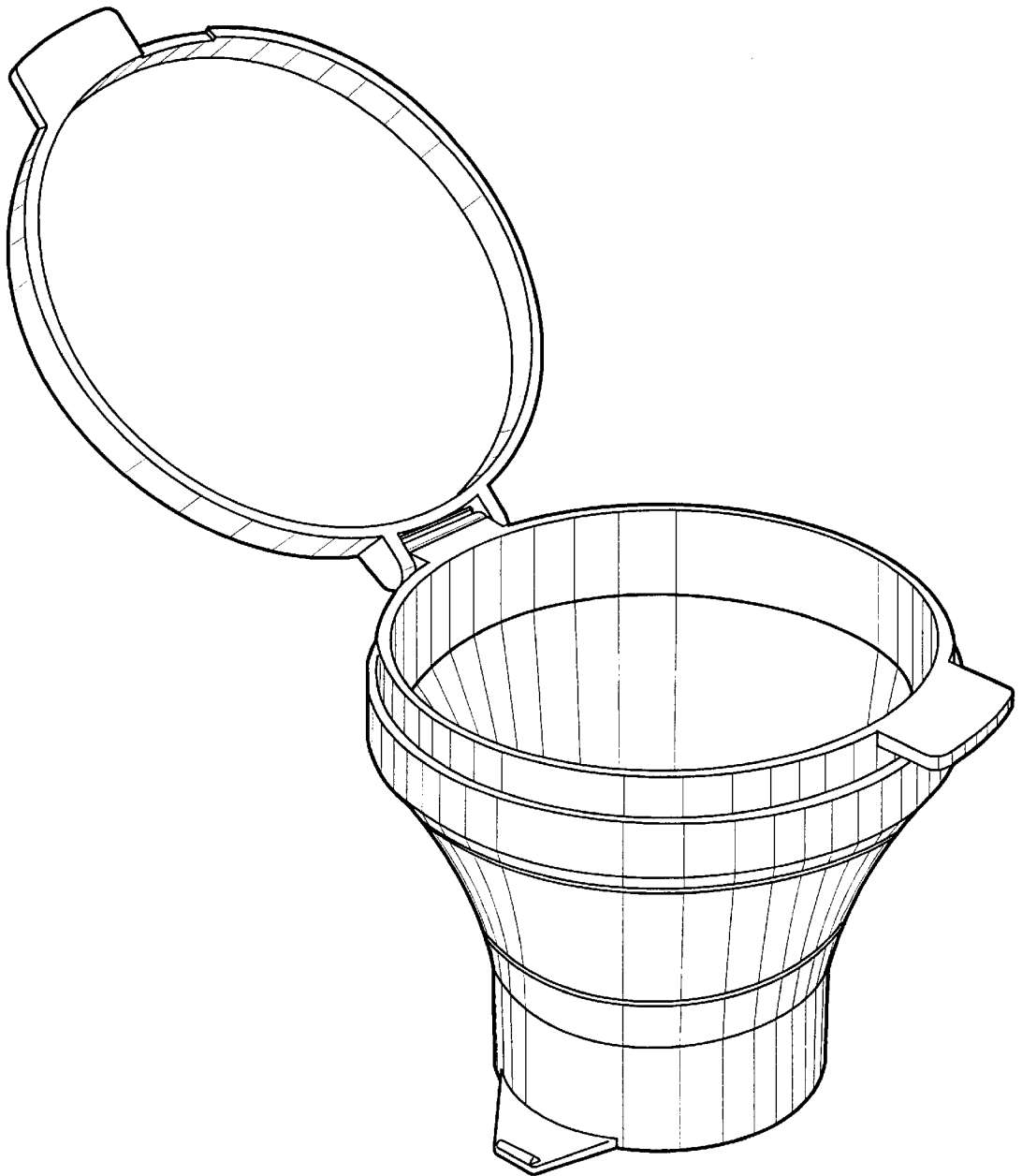

FIG. 2

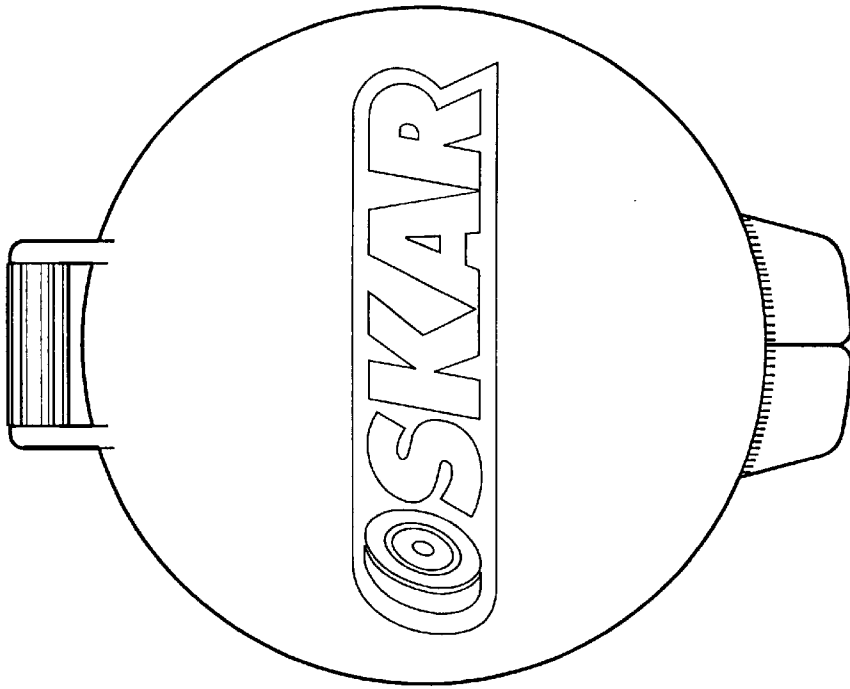

FIG. 3

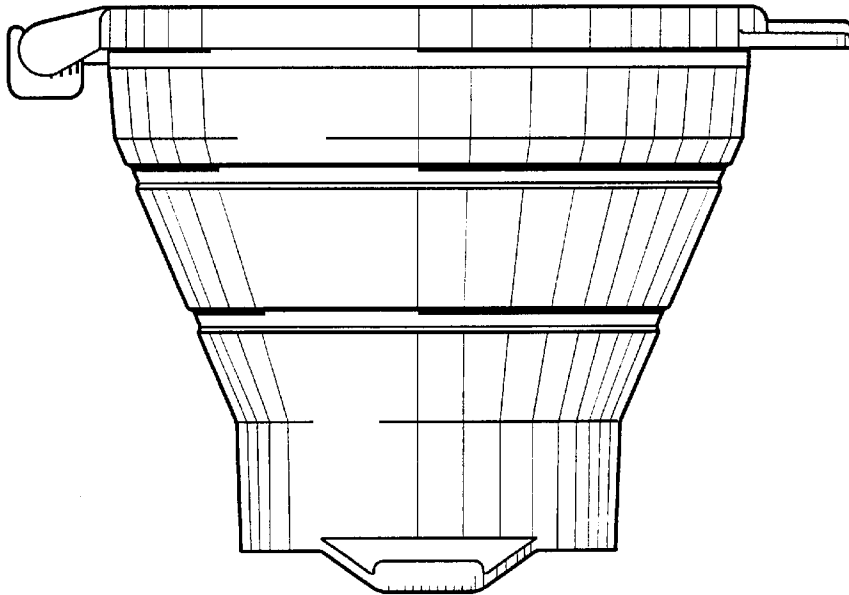

FIG. 4

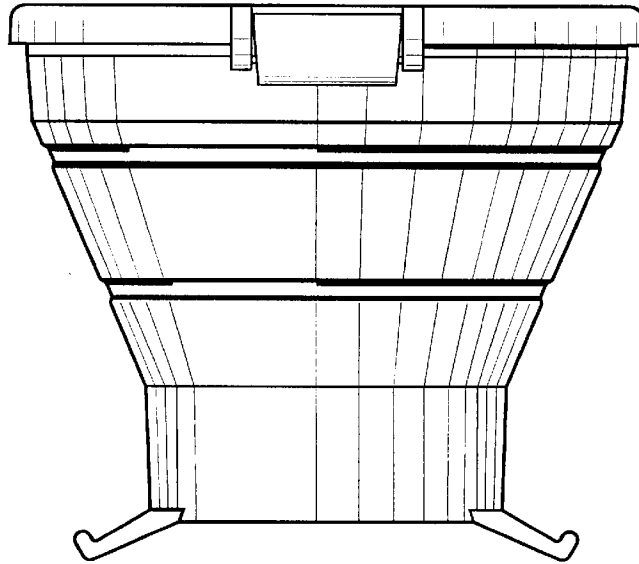

FIG. 5

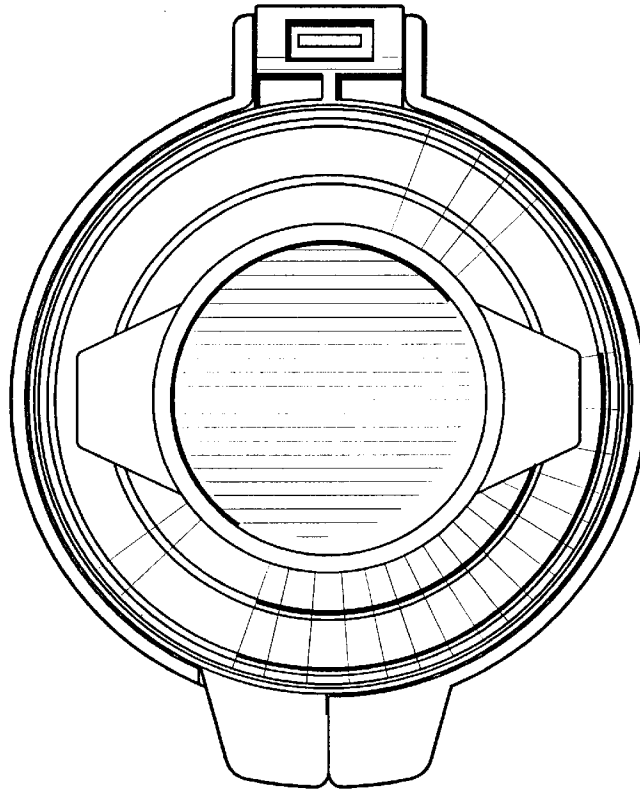

FIG. 6