

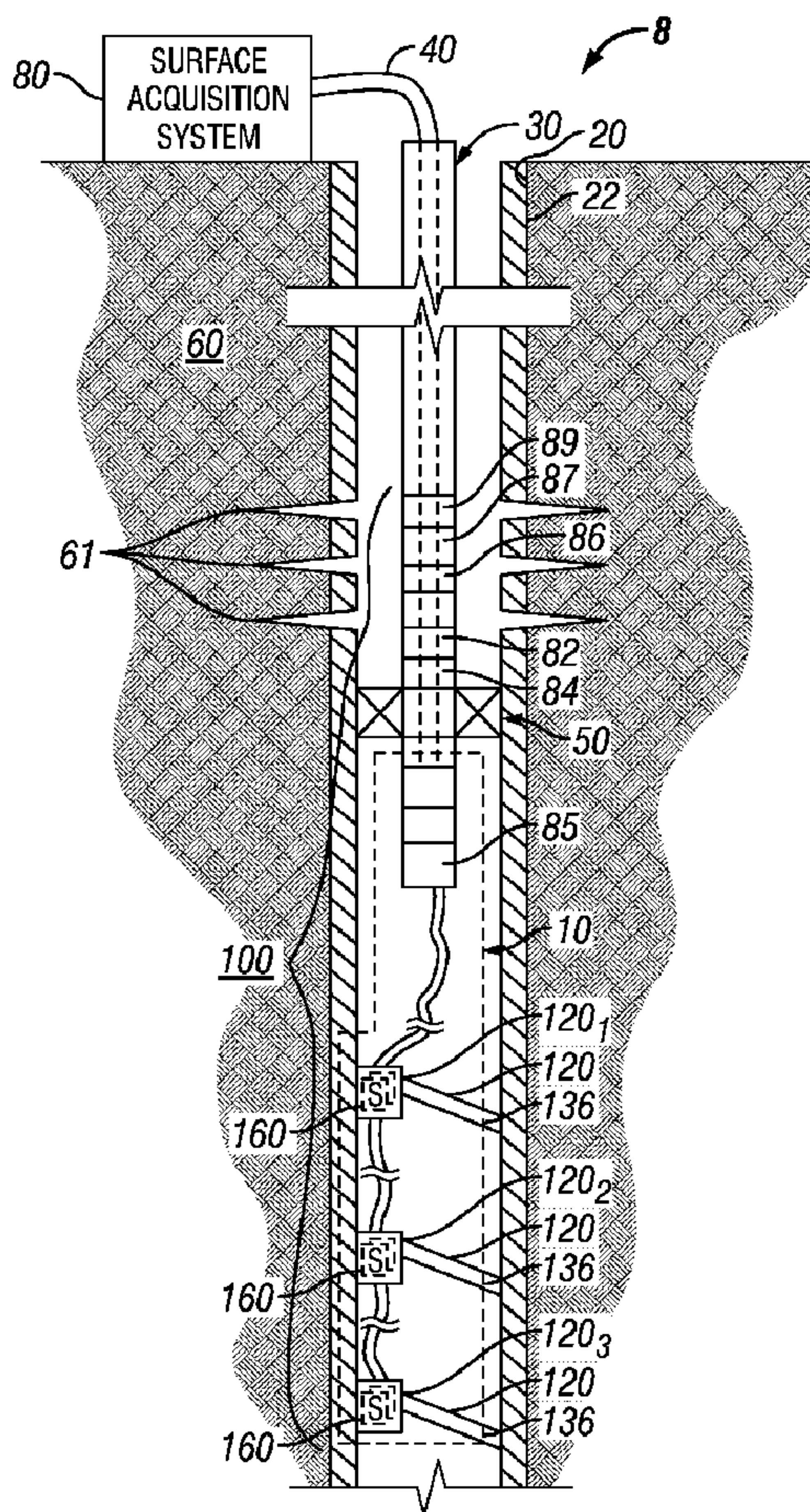

(86) Date de dépôt PCT/PCT Filing Date: 2007/03/13  
 (87) Date publication PCT/PCT Publication Date: 2007/09/20  
 (85) Entrée phase nationale/National Entry: 2008/09/10  
 (86) N° demande PCT/PCT Application No.: IB 2007/050843  
 (87) N° publication PCT/PCT Publication No.: 2007/105167  
 (30) Priorités/Priorities: 2006/03/14 (US60/782,161);  
 2006/12/28 (US11/617,372)

(51) Cl.Int./Int.Cl. *E21B 43/26* (2006.01),  
*E21B 47/01* (2006.01)  
 (71) Demandeur/Applicant:  
 SCHLUMBERGER CANADA LIMITED, CA  
 (72) Inventeurs/Inventors:  
 LAFFERTY, THEODORE JR., US;  
 UNDERHILL, WILLIAM, US;  
 NUTT, LES, US;  
 MARTINEZ, ALEJANDRO, US  
 (74) Agent: SMART & BIGGAR

(54) Titre : PROCEDE ET APPAREIL DE FRACTURATION HYDRAULIQUE ET DE SURVEILLANCE  
 (54) Title: METHOD AND APPARATUS FOR HYDRAULIC FRACTURING AND MONITORING



(57) Abrégé/Abstract:

A technique that is usable with a well includes deploying an assembly into a wellbore. The assembly includes at least one sensor. A fracturing fluid is injected under pressure into the wellbore to hydraulically fracture a subterranean formation of interest. The

(57) **Abrégé(suite)/Abstract(continued):**

technique includes isolating the sensor from the fracturing and measuring acoustical energy that is generated by the hydraulic fracturing using the sensor(s).

(12) INTERNATIONAL APPLICATION PUBLISHED UNDER THE PATENT COOPERATION TREATY (PCT)

(19) World Intellectual Property Organization  
International Bureau(43) International Publication Date  
20 September 2007 (20.09.2007)

PCT

(10) International Publication Number  
**WO 2007/105167 A3**

## (51) International Patent Classification:

*E21B 43/26* (2006.01)      *E21B 47/01* (2006.01)

## (21) International Application Number:

PCT/IB2007/050843

(22) International Filing Date: 13 March 2007 (13.03.2007)

(25) Filing Language: English

(26) Publication Language: English

## (30) Priority Data:

60/782,161      14 March 2006 (14.03.2006)      US

11/617,372      28 December 2006 (28.12.2006)      US

(71) Applicant (for CA only): **SCHLUMBERGER CANADA LIMITED** [CA/CA]; 525-3rd Avenue S.W., Calgary, Alberta T2P 0G4 (CA).(71) Applicant (for FR only): **SERVICES PETROLIERS SCHLUMBERGER** [FR/FR]; 42 rue Saint Dominique, F-75007 Paris (FR).(71) Applicant (for GB, JP, NL only): **SCLUMBERGER HOLDINGS LIMITED**; P.O. Box 71, Craigmuir Chambers, Road Town, Tortola (VG).(71) Applicant (for AL, AM, AU, AZ, BF, BG, BJ, BY, CF, CG, CI, CM, CO, CZ, DE, DK, GA, GN, GQ, GR, GW, HU, ID, IE, IL, IT, KG, KP, KR, KZ, LT, MD, ML, MR, MX, MY, NE, NO, NZ, OM, PL, RO, RU, SI, SK, SN, TD, TG, TJ, TM, TR, TT, UZ, ZA only): **SCHLUMBERGER TECHNOLOGY B.V.** [NL/NL]; Parkstraat 83-89, NL-2514 The Hague (NL).(71) Applicant (for AE, AG, AM, AT, AZ, BA, BB, BE, BR, BW, BY, BZ, CH, CN, CR, CU, CY, DM, DZ, EC, EE, EG, ES, FI, GD, GE, GH, GM, GT, HN, HR, IL, IN, IS, KE, KG, KM, KN, KZ, LA, LC, LK, LR, LS, LU, LV, LY, MA, MC, MD, MG, MK, MN, MW, MZ, NA, NG, NI, PG, PH, PT, RS, RU, SC, SD, SE, SG, SL, SM, SV, SY, SZ, TJ, TM, TN, TZ, UA, UG, UZ, VC, VN, ZM, ZW only): **PRAD RESEARCH AND DEVELOPMENT N.V.**; De Ruyterkade 62, Willemstad (AN).

(72) Inventors; and

(75) Inventors/Applicants (for US only): **LAFFERTY, Theodore Jr.** [US/US]; 1322 Shady Bend Drive, Sugar Land, TX 77478 (US). **UNDERHILL, William** [US/US];

[Continued on next page]

(54) Title: METHOD AND APPARATUS FOR HYDRAULIC FRACTURING AND MONITORING

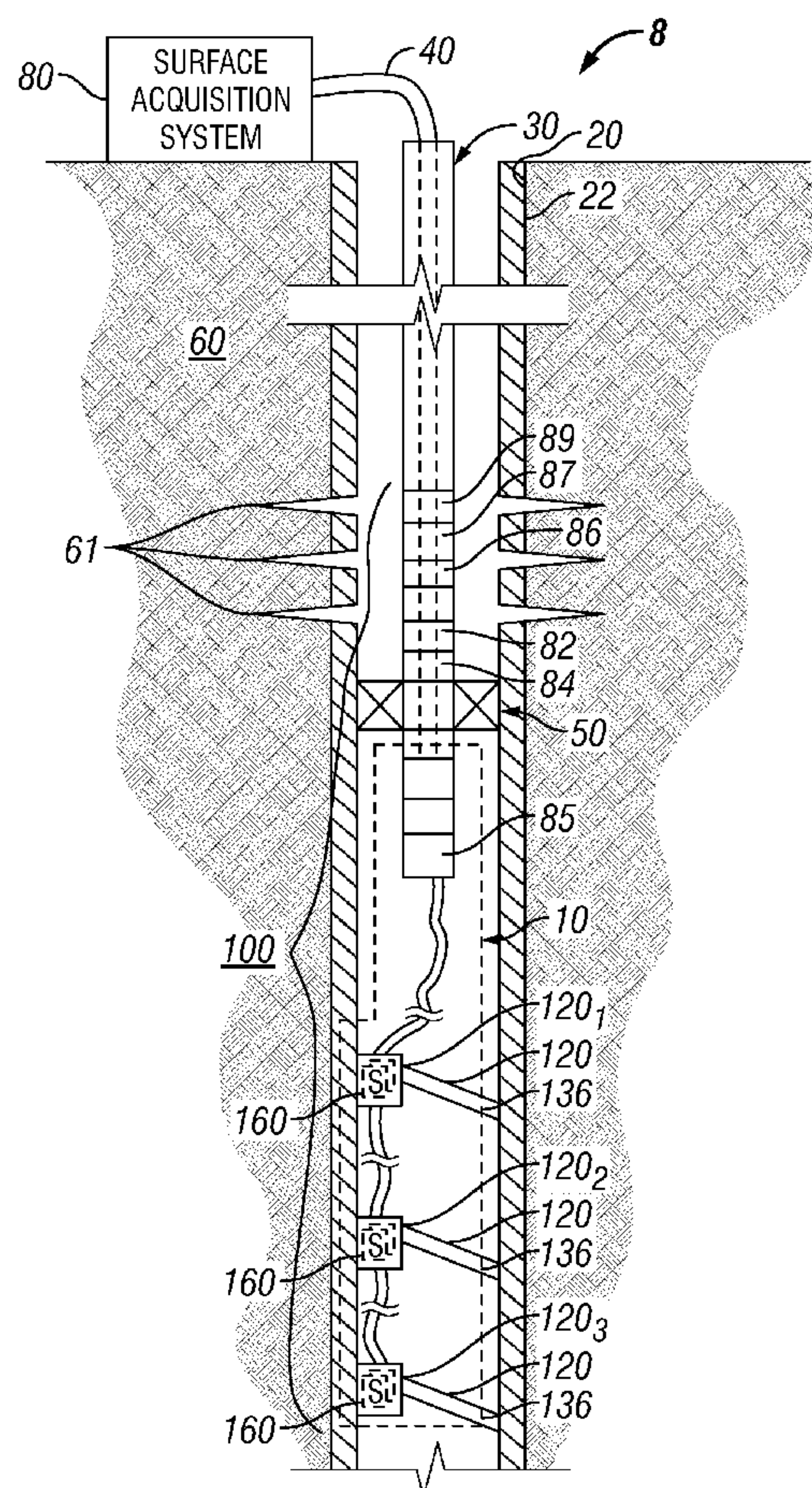

(57) Abstract: A technique that is usable with a well includes deploying an assembly into a wellbore. The assembly includes at least one sensor. A fracturing fluid is injected under pressure into the wellbore to hydraulically fracture a subterranean formation of interest. The technique includes isolating the sensor from the fracturing and measuring acoustical energy that is generated by the hydraulic fracturing using the sensor(s).

WO 2007/105167 A3

**WO 2007/105167 A3**

7402 Rustling Oaks Drive, Richmond, TX 77469 (US).  
**NUTT, Les** [GB/US]; 13707 Bayou Parkway Court, Houston, TX 77077 (US). **MARTINEZ, Alejandro** [CO/US]; 108 Jocelyn Circle, Victoria, TX 77901 (US).

GM, KE, LS, MW, MZ, NA, SD, SL, SZ, TZ, UG, ZM, ZW), Eurasian (AM, AZ, BY, KG, KZ, MD, RU, TJ, TM), European (AT, BE, BG, CH, CY, CZ, DE, DK, EE, ES, FI, FR, GB, GR, HU, IE, IS, IT, LT, LU, LV, MC, MT, NL, PL, PT, RO, SE, SI, SK, TR), OAPI (BF, BJ, CF, CG, CI, CM, GA, GN, GQ, GW, ML, MR, NE, SN, TD, TG).

(74) **Agent:** **CATE, Dave**; 110 Schlumberger Drive, MD-1, Sugar Land, TX 77478 (US).

(81) **Designated States** (*unless otherwise indicated, for every kind of national protection available*): AE, AG, AL, AM, AT, AU, AZ, BA, BB, BG, BR, BW, BY, BZ, CA, CH, CN, CO, CR, CU, CZ, DE, DK, DM, DZ, EC, EE, EG, ES, FI, GB, GD, GE, GH, GM, GT, HN, HR, HU, ID, IL, IN, IS, JP, KE, KG, KM, KN, KP, KR, KZ, LA, LC, LK, LR, LS, LT, LU, LY, MA, MD, MG, MK, MN, MW, MX, MY, MZ, NA, NG, NI, NO, NZ, OM, PG, PH, PL, PT, RO, RS, RU, SC, SD, SE, SG, SK, SL, SM, SV, SY, TJ, TM, TN, TR, TT, TZ, UA, UG, US, UZ, VC, VN, ZA, ZM, ZW.

(84) **Designated States** (*unless otherwise indicated, for every kind of regional protection available*): ARIPO (BW, GH,

**Published:**

- *with international search report*
- *before the expiration of the time limit for amending the claims and to be republished in the event of receipt of amendments*

(88) **Date of publication of the international search report:**

15 November 2007

*For two-letter codes and other abbreviations, refer to the "Guidance Notes on Codes and Abbreviations" appearing at the beginning of each regular issue of the PCT Gazette.*

## METHOD AND APPARATUS FOR HYDRAULIC FRACTURING AND MONITORING

### BACKGROUND

[0001] The subject matter of the present invention relates to a method and apparatus for hydraulic fracturing and monitoring.

[0002] Hydraulic fracturing is used to increase conductivity of a subterranean formation for recovery or production of hydrocarbons and to permit injection of fluids into subterranean formation or into injection wells. In a typical hydraulic fracturing operation, a fracturing fluid is injected under pressure into the formation through a wellbore. Particulate material known as proppant may be added to the fracturing fluid and deposited in the fracture as it is formed to hold open the fracture after hydraulic fracturing pressure is relaxed.

[0003] As the hydraulic fracturing fluid is delivered from the surface to the subterranean formation through the wellbore, it is important that the pressured fluid for fracturing be directed into the formation or formations of interest. Typically, the subterranean formation or formations are hydraulically fractured through either perforations in a cased well bore or in an isolated section of the open well bore. One important consideration for fracturing for hydrocarbon production or waste disposal is directing the fracture into a desired formation. The orientation of the hydraulic fracture is controlled by formation characteristics and the stress regime in the formation. It is important to monitor the fracture as it is being formed to insure that it does not extend beyond the intended zone and has the desired extent and orientation.

[0004] It is known that hydraulic fracturing operations in a wellbore generate significant seismic activity as a result of the fracture growth into a subterranean formation. Fluid injected under pressure into a subterranean formation causes a pressure build up until the in-situ stress in a subterranean formation is exceeded, resulting in fractures in the formation that extend some distance from the wellbore. This formation fracturing creates a series of small “micro-earthquakes” known as microseisms. These discrete, localized microseisms occur during the growth of fractures, and the amplitude of the seismic or acoustical energy

(compressional (“P”) waves and shear (“S”) waves) are generated with significant enough amplitude to be detected by remote sensors. Accordingly, by sensing and recording the P and S waves and their respective arrival times at each of the sensors, the acoustical signals can be processed in accordance with known seismic or earthquake monitoring methodology to determine the position of the microseisms. Hence, the geometry of the fracture and its location may be inferred. One method for determining the orientation of fractures resulting from hydraulic fracturing operations is described in U.S. Patent No. 6,985,816, incorporated herein by reference.

[0005] One method known for monitoring the location and size of a hydraulic fracture is called microseismic mapping. In this method, a second offset well is used for monitoring hydraulic fracturing activities in the primary treatment or injection well. In microseismic mapping, a plurality of acoustic sensors (e.g., geophones) are positioned in a well offset from the well to be fractured. These sensors in the offset well are used to record signals that result from microseisms caused by the stress induced in the subterranean surface formations by the hydraulic fracture fluid pressure build-up in the treatment or injection well.

[0006] Examples of microseismic monitoring are described in U.S. Pat. No. 5,771,170 by Withers, et al. and U.S. Pat. No. 5,996,726 by Sorrels and Warpinski. In the methods therein, location of fractures within an injection well are monitored in separate instrumented monitoring wells using acoustic signals resulting from microseismic events caused by the fracturing activity in the injection well. Separate dedicated monitoring wells however add significant expense to these methods. Limited efforts have been made to use devices deployed in injection or treatment wells for microseismic monitoring in treatment or injection wells. In U.S. Pat. No. 6,935,424, a method for mitigating risk of adversely affecting hydrocarbon productivity (e.g. screen out) during fracturing by monitoring the fracturing process is described. The method uses tiltmeters coupled to the casing or borehole wall in the well undergoing hydraulic fracturing to mechanically measure deformation, the deformation measurement being used to infer fracture dimensions. In this method however less than desirable coupling of the tiltmeters to the casing or borehole wall significantly impacts the accuracy of the inferred dimensions. In U.S. Pat. No. 5,503,225 acoustic sensors are deployed

in an injection well for microseismic monitoring. The sensors are isolated in the annulus of the waste injection well, with the sensors generally being attached to the tubing string. In such a configuration however the acoustic noise in the downhole tubing caused by the fluid injection will be sensed by such a system and likely will significantly mask any sensed microseismic events. While these methods eliminate the need and expense of the dedicated monitoring wells, the limitations of each preclude their use to accurately distinguish microseismic events.

[0007] Thus, there is a continuing need for better ways to reliably and accurately monitor hydraulic fracturing and injection operations.

#### SUMMARY

[0008] In an embodiment of the invention, a technique that is usable with a well includes deploying an assembly into a wellbore. The assembly includes at least one sensor. A fracturing fluid is injected under pressure into the wellbore to hydraulically fracture a subterranean formation of interest. The technique includes measuring acoustical energy that is generated by the hydraulic fracturing using the sensor(s).

[0009] In another embodiment of the invention, an apparatus for use in a well includes an assembly that has a tool body with at least one acoustic energy sensor that is disposed thereon. The assembly also includes an isolation device to isolate the acoustic energy sensor from a hydraulic fracture operation.

[0010] Advantages and other features of the invention will become apparent from the following drawing, description and claims.

## BRIEF DESCRIPTION OF THE DRAWINGS

[0011] Fig. 1 is a well according to an embodiment of the invention.

[0012] Fig. 2 is a schematic diagram of a sensor sonde according to an embodiment of the invention.

[0013] Fig. 3 is a flow diagram depicting a technique to monitor acoustical energy that is generated by hydraulic fracturing according to an embodiment of the invention.

[0014] Fig. 4 is a flow diagram depicting a technique to perform hydraulic fracturing in different zones of a well and monitor the fracturing according to an embodiment of the invention.

[0015] Fig. 5 is a flow diagram depicting a technique to monitor acoustical energy that is generated by hydraulic fracturing according to an embodiment of the invention.

## DETAILED DESCRIPTION

[0016] Referring to Fig. 1, in accordance with an embodiment of the invention, a well 8 includes acoustic energy sensors 160 that are located downhole for purposes of monitoring the acoustical energy that is generated by hydraulic fracturing. Sensors 160 may be isolated from a formation of interest 60 in which hydraulic fracturing occurs. Due to the isolation, flow noise attributable to the fracturing operation does not affect the measurements by the sensors 160, and furthermore, the sensors 160 are protected from the impact of the fracture treatment.

[0017] In accordance with some embodiments of the invention, the sensors 160 are part of sensor sondes 120 (sensor sondes 120<sub>1</sub>, 120<sub>2</sub> and 120<sub>3</sub>, being depicted as examples in Fig. 1) of a borehole monitoring assembly 10 of a downhole borehole assembly 100. In addition to the borehole monitoring assembly 10, the borehole assembly 100 optionally includes an isolation device, such as a isolation device 50 (a compression-set packer, a mechanically-set packer, a hydraulically-set packer, a weight-set packer, swellable bladder, plug, etc., as just a few examples), for purposes of isolating the sensor sondes 120 (and thus, the sensors 160) from the fracturing operation.

[0018] The borehole assembly 100 may be run into the well 8 using one of many conveyance mechanisms, such as a tubular string 30 that is depicted in Fig. 1. As a more specific example, the string 30 may be coiled tubing.

[0019] In general, a surface acquisition system 80 may be in communication with the borehole monitoring assembly 100 via a communication line 40, such as a wireline, slickline, fiber optics or a fiber optics tether. Fiber optic tether refers to fiber optics deployed within a protective cover or small diameter protective tubing. One example of a data receiving and processing system that may serve as the surface acquisition system 80 is described in U.S. Patent No. 6,552,665, which is incorporated herein in its entirety. The communication line 40 may be contained or deployed in the string 30 to provide communication from the surface control system to the borehole monitoring assembly 100 or communication from the borehole monitoring assembly 100 to the surface control system or both. Communication and/or power may be provided by the communication lines 40, depending on the particular embodiment of the invention.

[0020] The borehole monitoring assembly 10 may be any assembly or tool, which is suited to monitor acoustic signals in a wellbore. In accordance with some embodiments of the invention, each sonde 120 of the borehole monitoring assembly 10 may be a similar sensor to the sonde that is described in U.S. Patent No. 6,170,601, which is hereby incorporated by reference in its entirety.

[0021] Fig. 2 depicts an exemplary embodiment of the sonde 120 in accordance with some embodiments of the invention. In general, the sonde 120 includes a tool body 124, which has a cavity 130 in an opening in the wall of the tool body 124. The cavity 124 receives an acoustic energy sensor package 140, which is positioned in the cavity 130 and is mounted on resilient mounts 150 (springs, for example) to press the acoustic sensor package 140 against the borehole wall (or casing string 22, if the well is cased), yet isolate the sensors 160 of the package 16 from fluid-conveyed pressure disturbances. The sonde 120 may include three of the sensors 160, each of which senses acoustic energy along a different axis (x, y or z axis). Referring to Fig. 2 in conjunction with Fig. 1, the sonde 120 may also include an arm 136 that is activated to press the sonde 120 against the borehole wall (or casing string 22, if the well 10 is cased) for purposes of placing the sensors 160 in proximity to the wellbore or casing string 22.

[0022] Referring back to Fig. 1, as noted above, the well 8 may be cased (via the casing string 22) or uncased, depending on the particular embodiment of the invention. If installed, the casing string 22 may extend from the surface along the entire length of a wellbore 20, or only along a portion of the wellbore 20. Furthermore, in accordance with other embodiments of the invention, the wellbore 20 in which the borehole assembly 100 is deployed may be a deviated or lateral wellbore. In some embodiments in a deviated or lateral wellbore, a tractor may be used to deploy the borehole assembly 100. Furthermore, the well 10 may be a subterranean or a subsea well, depending on the particular embodiment of the invention. Thus, many variations are possible and are within the scope of the appended claims.

[0023] In the state of the well that is depicted in Fig. 1, the well 8 has been perforated in a previous trip by a perforating gun to form corresponding perforations in the casing string 22 and corresponding perforation tunnels 61, which extend into the formation of interest 60.

[0024] The borehole assembly 100 is deployed in the well 8 for purposes of hydraulic fracturing and monitoring of the fracturing. Such hydraulic fracturing may be desired or performed for a variety of purposes, such as but not limited to increasing or improving hydrocarbon recovery from the formation of interest 60 or injecting fluid, such as water, produced water, enhanced oil recovery fluids, or gas into formation of interest 60. The term fracturing fluid as used herein includes any fluid injected for the purposes of fracturing the formation and includes but is not limited to treatment fluids, enhanced recovery fluids, and disposal fluids. There is shown in Fig. 1 only one subterranean formation of interest 60 for the purposes of illustration. It is contemplated that there may be multiple subterranean formations of interest 60 in any wellbore 20; and these multiple formations may be hydraulically fractured separately, together, or in various combinations as the operator so desires.

[0025] Isolation device 50 is also deployed into the wellbore on a string 30, as part of the borehole assembly 100. More specifically, the isolation device 50 may be positioned along the string 30 above the borehole monitoring assembly 10.

[0026] The sensors 160 form an array of sensors and may be selected from any appropriate sensing devices such as geophones, hydrophones, or accelerometers, and various combinations that generate signals in response to received acoustic energy. Any one type of acoustic energy sensor or a combination of types may be used. The acoustic energy sensor or sensors should have good sensitivity to acoustic energy in the microseismic frequency band greater than 30 Hz. This band may extend as high as 4 kiloHertz (kHz), as an example.

[0027] More than one acoustic energy sensor may be used in combination with other acoustic sensors to form an acoustic energy sensor package. Embodiments may comprise a plurality of tri-axial (3 orthogonal) geophones to provide sensing capabilities in three directions. Such acoustic sensor packages may be spaced at desired intervals (e.g. 50 ft) along the wellbore 20. Acoustic sensor packages may be coupled to the wellbore wall or casing 22 via an anchoring system for borehole seismic tools.

[0028] The signals that are generated by each of the sensors 160 in response to acoustical energy are digitized and transmitted through the communication line 40 to the surface acquisition system 80, at the surface of the well 8. The sensors 160 may provide a digital or optical signal directly to the communication line 40 or a converter may be used to convert the acoustic signals received by the sensors to digital or optical signals for transmission. In some embodiments, the surface acquisition system 80 may employ methods, such as digital filters, to remove noise from the hydraulic fracturing pumping operations from the generated signals. In some embodiments, the signals generated by each sensor are recorded in one or more memory devices that may be part of the borehole monitoring assembly 10, the memory devices generally being recoverable with the bottomhole monitoring assembly 10. In such embodiments using memory devices, the signals may also be transmitted via the communication line 40, while in other embodiments the signals are not also transmitted via a communication line, as the sensor data that is stored in the memory devices may be retrieved after the borehole assembly 100 is retrieved from the well.

[0029] As depicted in Fig. 1, the borehole monitoring assembly 10 and the acoustic energy sensors 160 thereof are positioned in the wellbore at a location

that is not adjacent to the formation of interest 60. The borehole monitoring assembly 10 may be positioned below the formation of interest 60. In the event that the wellbore is cased, borehole monitoring assembly 10 may be positioned in the wellbore in a location that it not adjacent to the perforated zone in the casing. The borehole monitoring assembly 10 may be placed below the perforated zone and thus, as depicted in Fig. 1, the sondes 120 may be suspend from a cable from a tubular body that is mounted to the isolation device 50 and forms the lower end of the string 30. The isolation device 50 is deployed in the wellbore 20 to separate the borehole monitoring assembly 10 from the subterranean formation of interest 60. In this manner, the borehole monitoring assembly 10 is isolated from hydraulic fracturing or injection activity undertaken in subterranean formation of interest 60.

[0030] In some embodiments of the invention, a noise suppression device or devices such as a shock absorber may be provided, being placed between isolation device 50 and borehole monitoring assembly 10. In some embodiments, noise suppression methods, such as slacking the connecting cable between components, may be used to reduce the possibility of noise transmission. Noise suppression devices or methods similarly may be used between the sensors 160 in an array. In some embodiments of the invention, noise suppression may be performed by digitally processing the signals generated by the measurements made by the acoustic energy sensors.

[0031] Borehole assembly 100 may also include apparatuses or features for use in the hydraulic fracturing process. In the event that conveyance 30 is coiled tubing, one such apparatus may be a jetting nozzle 86 that is placed above the isolation device 50 to permit fluids to be pumped down the string 30 and out the jetting nozzle 86 to clean out debris such as sand that may accumulate above the packer 30. The jetting nozzle 86 may also be used for purposes of perforating the casing string 22 and forming the perforation tunnels 61 in lieu of a perforating gun. In this regard, an abrasive fluid may be communicated downhole through the central passageway of the string 30, and the abrasive fluid is radially directed by the jetting nozzles 86 toward the casing string 22 so that the resultant jets perforate the casing string 22 and form tunnels into the surrounding formation.

[0032] The borehole assembly 100 may include a feature such as a clean-out port, which may be selectively opened or closed above located above isolation device 50 to permit, if desired, fluid pumped down the annulus to reverse flow the fluid up coiled tubing. Methods such as ball drops or mechanical actuation may be used to selectively open or close a clean-out port.

[0033] In some embodiments, borehole assembly 100 may include one or more additional isolation devices located above borehole monitoring assembly 10. Additional isolation devices may be single or multi-set.

[0034] The borehole assembly 100 may include one or more additional devices to provide wellbore information. For example, the borehole assembly 100 may further include a pressure or temperature sensor or both. In some embodiments of the invention, a gyroscope may be provided for use in orientating the sensors 160 or for determining the orientation of the borehole monitoring assembly 10 to permit subsequent data adjustment. Alternatively the sensors may be orientated by methods such as a three component hodogram analysis that uses the recording of a calibration shot in a nearby well or at the surface. By recording and analyzing one or more such shots the tool orientation may be calculated by the known methods such as using plane geometry and the assumption of a straight ray from source to receiver, projecting the ray onto a perpendicular plane and rotating the projection through the horizontal polarization angle to give the direction of the x-component sensor and the relative bearing angle or the method of calculating the relative bearing angle from the 3C polarization of the direct P-wave arrival as described in Becquey, M. and Dubesset, M., 1990, *Three-component sonde orientation in a deviated well* (short note): Geophysics, Society of Exploration. Geophysics, 55, 1386-1388.

[0035] In accordance with some embodiments of the invention, the borehole assembly 100 may include other devices, which are directed to other functions. For example, in accordance with some embodiments of the invention, the borehole assembly 100 may include a casing collar locator (CCL) 87 that is used for purposes of precisely locating the borehole assembly 100 downhole or other tool. In this regard, the CCL 87 may be a magnetically-sensitive device that generates a signal (observed at the surface of the well 8) for purposes of detecting casing joints of the casing 22 for purposes of precisely locating the assembly 100.

This may be helpful for purposes of precisely locating the jetting nozzles 86 when the jetting nozzles 86 perforate the casing 22 and the formation of interest 60. As another example of another potential device of the borehole assembly 100, in accordance with some embodiments of the invention, the assembly 100 may include a tension sub 85, which is located below the isolation device 50 and is used to monitor the tension of the cable, which extends to the sondes 120. In this regard, should the cable or sondes 120 become lodged in the well 8, the corresponding tension indicative of this event is sensed by the tension sub 85 and communicated to the surface of the well. Therefore, corrective measures may then be undertaken for purposes of safely dislodging the sondes 120.

[0036] As another example, the borehole assembly may include a supplemental sensor, for example a pressure or temperature sensor, capable of providing a downhole measurement. In this regard, the measurement obtained using the supplemental sensor may be used in conjunction with or separately from the measurements obtained using sensors 160 to monitor hydraulic fracturing. In some embodiments, the supplemental sensor may be an additional acoustic sensor, such as a hydrophone, useful for measuring noise in the form of borehole acoustic waves. The supplemental sensor may be an accelerometer. In some embodiments, a plurality of supplemental sensors, specifically acoustic sensors, may be provided. Output from this supplemental sensor may be used to digitally suppress or remove noise by processing the measurements from the acoustic sensor(s). This use is different from the use of measurements from acoustic sensors in an array to eliminate noise by cumulative processing of the measurements such as known for vertical seismic profiles.

[0037] The borehole assembly 100 may also include, in accordance with embodiments of the invention, a remotely-actuated latch, or connector 90, for purposes of selectively connecting the borehole assembly 100 to and releasing the assembly 100 from the string 30 (thereby leaving the assembly 100 downhole) when multiple zones are treated, as further described below. Thus, many variations are possible and are within the scope of the appended claims.

[0038] The hydraulic fracturing and monitoring may proceed as follows in accordance with some embodiments of the invention. The wellbore 20 is first completed with the casing 22, and then, the casing 22 is perforated at one or more

subterranean formations of interest 60. In accordance with embodiments of the invention, the borehole monitoring assembly 10 may then be conveyed into the wellbore 20 on the string 30. The isolation device 50 is simultaneously conveyed in wellbore 20 on the string 30 at a desired position above assembly 10. The isolation device 50 is set in place to provide a seal in the annulus between the string 30 and the casing 22, thereby isolating borehole monitoring assembly 10 in wellbore 20 below isolation device 50. If additional isolation devices are provided, they may be actuated or set in place to provide further isolation between the borehole monitoring assembly 10 and the isolation device 50.

[0039] Hydraulic fracturing fluid or injection fluid is then pumped at pressure down the annulus formed between conveyance 30 and casing 22 or wellbore wall and into the subterranean formation of interest 60. The hydraulic fracturing fluid may be any fluid useful for fracturing a subterranean formation, including but not limited to wellbore treatment fluids, hydrocarbons, water, produced water, disposal water, foamed fluids or gases, such as natural gas or CO<sub>2</sub>.

[0040] The isolation device 50 and if provided, additional isolation device or devices, separate borehole monitoring assembly 10 from hydraulic fracturing fluids and operations performed in the wellbore above isolation device 50. Isolation device 50 may be any packer, inflatable or mechanical device capable of being set and released that provides sufficient sealing pressure within the wellbore to isolate the borehole monitoring assembly from the pressured hydraulic fracturing or injection fluid. In embodiments of the invention where the borehole monitoring assembly 10 is deployed in the wellbore below the isolation device 50, the isolation device 50 includes feed-throughs to permit communication line 40 to pass through the isolation device 50 and to borehole monitoring assembly 10. Some embodiments may include stiff bridles or deployment bars for use in deploying borehole sensor assembly 10 in deviated, horizontal or pressurized wells.

[0041] In accordance with embodiments of the invention described herein, referring to Fig. 3, a technique 200 may be used to monitor the hydraulic fracturing of a particular formation of interest. Pursuant to the technique 200, the borehole assembly 100 is run into the well into position, pursuant to block 204, the borehole assembly comprising an acoustic sensor. A hydraulic fracturing

operation is then performed by pumping fracturing fluid into the wellbore at pressure, pursuant to block 206. The one or more acoustic sensors are used to monitor acoustic energy pursuant to block 208. The acoustic energy monitored may be from fracturing operations, or may result from fracturing operations in which the hydraulic fracturing fluid comprises an acoustic signal generating element, such as a noisy proppant described in U.S. Pat. No. 7,134,492, incorporated herein in its entirety by reference. Sensor 160 is used to monitor the operation or the signals generated by the acoustic signal generating element.

[0042] Although the hydraulic fracturing and monitoring of a single formation of interest, or zone, is described herein for purposes of clarifying certain aspects of the invention, it is noted that other embodiments are possible and are within the scope of the appended claims. More specifically, in accordance with some embodiments of the invention, the borehole assembly 100 may be used in conjunction with the hydraulic fracturing and monitoring of several zones in the well.

[0043] In this manner, referring to Fig. 4, in accordance with some embodiments of the invention, a technique 250 includes running (block 254) a perforating device downhole in a well to a particular depth. The perforating device is then used to perforate the casing or wellbore (block 258). The borehole assembly 100 is positioned in the well, pursuant to block 262. Next, the isolation device 50 is set (block 266) and a fracturing operation is subsequently performed and the sensors 160 are used to monitor the operation, pursuant to block 270. In some embodiments, a fracturing model may be established and updated using a measurement from sensor 160.

[0044] After the completion of the hydraulic fracturing operation, a determination is made (diamond 274) whether another zone is to be fractured. If not, then the borehole assembly 100 is pulled out of the well, pursuant to block 278. If another zone is to be fractured, then the next zone is perforated, pursuant to block 254; and pursuant to blocks 258, 262, 266 and 270, another zone is hydraulically fractured and monitored.

[0045] Thus, pursuant to the technique 250, zones may be fractured and monitored in the well as set forth in Fig. 4. It is noted that the technique 250 is

provided for purposes of an example, as other techniques may be used for purposes of hydraulic fracturing and monitoring, in accordance with other embodiments of the invention.

[0046] Referring to Fig. 5, in accordance with some embodiments of the invention, a technique 300 includes running (block 304) a perforating device downhole in a well to a particular depth. The perforating device is then used to perforate the casing or wellbore (block 308). The borehole assembly 100 is positioned in the well, pursuant to block 312. In some embodiments, borehole assembly 100 may comprise the perforating device. A fracturing operation is subsequently performed and the sensors 160 are used to monitor the operation, pursuant to block 320.

[0047] After the completion of the hydraulic fracturing operation, a determination is made (diamond 324) whether another zone is to be fractured. If not, then the borehole assembly 100 is pulled out of the well, pursuant to block 328. If another zone is to be fractured, then the perforated next zone is perforated, pursuant to block 324; and pursuant to blocks 304, 308, 312, and 320, another zone is hydraulically fractured and monitored.

[0048] Thus, pursuant to the technique 300, zones may be fractured and monitored in the well as set forth in Fig. 5. It is noted that the technique 300 is provided for purposes of an example, as other techniques may be used for purposes of hydraulic fracturing and monitoring, in accordance with other embodiments of the invention.

[0049] The borehole monitoring assembly 100 and techniques that are described herein may offer one or more advantages and/or improvements over conventional hydraulic monitoring techniques and devices. In particular, placement of the borehole monitoring assembly in the injection well rather than a separate monitoring well reduces the time and expense required for drilling a separate well. Placing the acoustical sensors below the packer isolates the sensors from the fracturing fluid and reduces the risk of damage to the sensors from the fracturing fluid as it is pumped down the wellbore. Similarly, placing communication line 40 within the string 30 isolates it from the fracturing fluid pumped down the annulus and significantly reduces the possibility of erosion or

damage to the communication line. Furthermore, the placement of sensors 160 below the isolation device 50 has the effect of providing isolation from flow-induced noise.

[0050] Prior to the present invention, noise generated by pumping fracturing fluid in a wellbore has inhibited the ability to make successful microseismic measurements in the injection well. Several elements are used individually or in combination in the present invention to isolate and attenuate wellbore noise. Placing the acoustic energy sensor or sensors below the isolation device 50 provides a barrier to direct flow noise. Isolation device 50 is designed to efficiently allow setting/unsetting, cleaning of sand deposited on top, and enablement of noise isolation techniques (e.g., slacking). Configuring sensors 160 in an acoustic energy sensor package and mechanically isolating the sensor package 140 (see Fig. 2) from the tool body 124 may be used to attenuate noise (known as tubewaves) propagating in the wellbore fluid. Slacking communication line 40 may be used to attenuate noise propagating along the communication line 40 or borehole monitoring assembly 10. Isolation device 50 may comprise a compressional setting that is operational on a downward movement that accommodates slacking of communication line 40.

[0051] Shock absorbers designed to attenuate noise propagating in the bottom-hole-assembly may be inserted between isolation device 50 and the acoustic sensors. Digital filtering may be used to identify upward and downward propagating noise with distinctly different characteristics from the microseisms. Such digital filtering techniques such as adaptive beamforming or velocity filtering may be used to attenuate noise. A sub-array of hydrophones placed within an array of geophones or accelerometers may be useful for identifying and removing propagating fluid (tube) waves. Additionally, pumping noise is at low frequencies (<20Hz) much below the typical microseismic band and may be substantially removed by conventional high-pass filters.

[0052] The borehole assembly 100 may further include other measurement devices such as pressure, temperature, gyroscopes, or any other device useful for measuring indications of fracture characteristics. The borehole assembly 100 may also include fracturing tools positioned above the isolation device 50 for use in the hydraulic fracturing process, such as jetting nozzle, clean-up port, etc.

Furthermore, the borehole assembly 100 may include a single or multi-set isolation device above the measurement devices to protect it from the impact of the fracture treatment.

[0053] Although directional and terms of orientation, such as "vertical," "up," "down," etc. have been used for reasons of convenience in the foregoing description, it is understood that such directions and orientations are not necessary to practice the invention. For example, in accordance with other embodiments of the invention, the borehole assembly 100 may be used in a lateral wellbore. Therefore, many variations are contemplated and are within the scope of the appended claims.

[0054] While the present invention has been described with respect to a limited number of embodiments, those skilled in the art, having the benefit of this disclosure, will appreciate numerous modifications and variations therefrom. It is intended that the appended claims cover all such modifications and variations as fall within the true spirit and scope of this present invention.

## WE CLAIM:

1. A method usable with a well, comprising:  
deploying an assembly into a wellbore, the assembly comprising at least one sensor;  
injecting a fracturing fluid under pressure into the wellbore to hydraulically fracture a subterranean formation of interest;  
isolating the sensor from the fracturing; and  
measuring acoustical energy generated by the hydraulic fracturing using said at least one sensor.
2. The method of claim 1, wherein the isolating comprises setting a packer of the assembly.
3. The method of claim 2, further comprising:  
positioning said at least one sensor below the packer.
4. The method of claim 2, further comprising:  
releasing the packer;  
repositioning the borehole assembly in the wellbore; and  
repeating the injecting and isolating.
5. The method of claim 1, wherein the deploying comprises deploying the assembly on a string, the method further comprising disposing a communication line inside the string to establish communication between said at least one sensor and the surface of the well.
6. The method of claim 1, wherein said at least one sensor comprises a plurality of sensors, the method further comprising:  
spacing the sensors along the wellbore.
7. The method of claim 1 further comprising:  
retrieving the assembly from the wellbore.
8. The method of claim 1, wherein the measuring occurs concurrently with the injecting.

9. The method of claim 1, further comprising:  
storing data indicative of the acoustical energy measured by by said at least one sensor in a memory of the assembly; and  
retrieving the data from the memory after the assembly is retrieved from the well.
10. A method for monitoring hydraulic fracturing comprising:  
a) deploying a borehole assembly into a wellbore on a coiled tubing having a communication line disposed therein, the borehole assembly comprising borehole monitoring assembly positioned below a packer, the borehole monitoring assembly comprising at least one acoustic energy sensor;  
b) placing the borehole assembly below a subterranean formation of interest,  
c) setting the packer below the subterranean formation of interest;  
d) injecting a fracturing fluid under pressure down the annulus, thereby hydraulically fracturing the subterranean formation of interest; and  
e) using the acoustic energy sensor to make a measurement of acoustical energy generated by the hydraulic fracturing.
11. The method of claim 10, further wherein the communication line is selected from the group consisting of wireline, slickline, fiber optics and a fiber optic tether.
12. The method of claim 10, wherein the borehole monitoring assembly comprises more than one sensor, the sensors being spaced along the wellbore, the sensors being separated from the subterranean formation by the packer.
13. The method of claim 10, further comprising the steps (f) of releasing the packer and (g) moving the borehole assembly in the wellbore, wherein steps (b) through (f) are repeated.
14. The method of claim 10, wherein the acoustical energy measurement comprises communicating via the communication line.
15. The method of claim 14, further wherein the step of injecting a fracturing fluid comprises modifying based on the acoustical energy measurement.

16. The method of claim 10, further comprising retrieving the borehole assembly from the wellbore.

17. The method of claim 10, further comprising establishing a fracturing model and updating the fracturing model using at least one acoustical energy measurement.

18. An wellbore apparatus for hydraulic fracture monitoring comprising a borehole assembly deployed on coiled tubing,  
the assembly having a tool body with a least one acoustic energy sensor disposed therein, an isolation device, and at least one washout port adjacent to the isolation device,  
the assembly being connected to coiled tubing having a communication line disposed therein.

19. The apparatus of claim 18, wherein the at least one acoustic energy sensor comprises selected from the group consisting of geophone, hydrophone, and accelerometer.

20. The apparatus of claim 18, wherein the isolation device comprises a packer.

21. The apparatus of claim 18, further comprising means to process data from the acoustical energy sensor.

22. An apparatus usable with a well, comprising:  
a tool body;  
an isolation device disposed on the tool body;  
at least one acoustic sensor disposed on the tool body to monitor hydraulic fracturing.

23. The apparatus of claim 22, wherein said at least one acoustic sensor comprises at least one of a geophone, hydrophone and accelerometer.

24. The apparatus of claim 22, further comprising:  
a string to convey the isolation device and said at least one acoustic sensor  
downhole as a unit.
25. The apparatus of claim 22, further comprising:  
a remotely-activated connector to selectively connect the isolation device to a  
tubular string.
26. The apparatus of claim 22, wherein the isolation device comprises a  
packer.
27. The apparatus of claim 22, further comprising:  
a memory connected to and deployed downhole with the tool body to store  
data provided by said at least one sensor such that the data is retrieved from the  
memory after the apparatus is retrieved from the well.
28. A method for monitoring hydraulic fracturing comprising:  
a) deploying a borehole assembly into a wellbore, the borehole assembly  
comprising a borehole monitoring assembly having at least one acoustic energy  
sensor;  
b) injecting a fracturing fluid under pressure, thereby hydraulically fracturing  
a subterranean formation of interest; and  
c) using the acoustic energy sensor to make a measurement of acoustical  
energy.
29. The method of claim 28, wherein the borehole assembly further  
comprises a supplemental sensor.
30. The method of claim 28, wherein the fracturing fluid comprises an  
acoustical energy generating element.
31. The method of claim 28, wherein the fracturing fluid comprises a noisy  
proppant.
32. The method of claim 28, further comprising the steps (e) of moving the  
borehole assembly in the wellbore, wherein steps (b) through (c) are repeated.

33. The method of claim 29, wherein the supplemental sensor is an acoustic energy sensor.

34. The method of claim 33, further comprising the step of using the output from the supplemental sensor in processing the measurement of acoustic energy.

35. The method of claim 28, further comprising the orientating the borehole assembly.

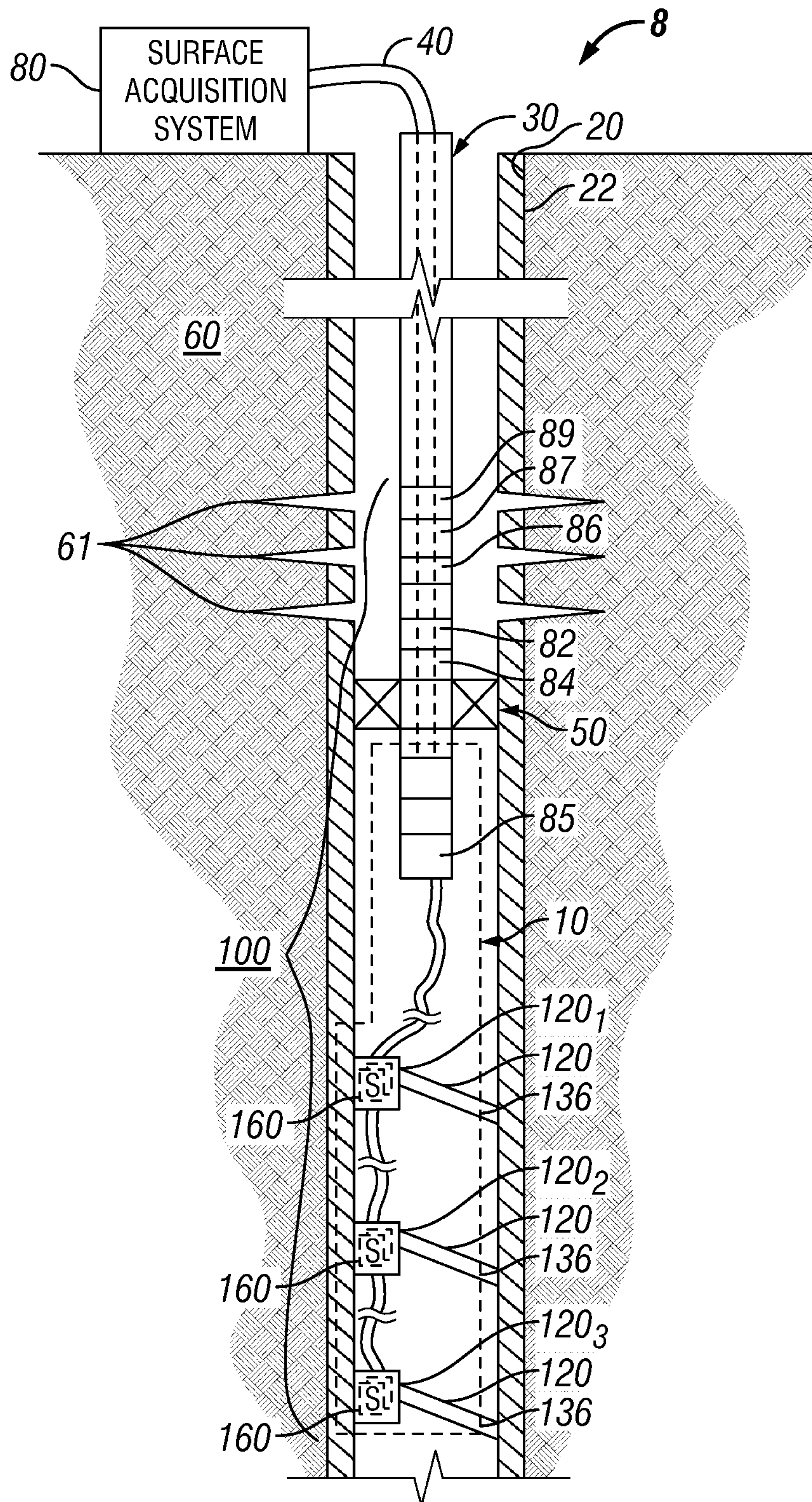

FIG. 1

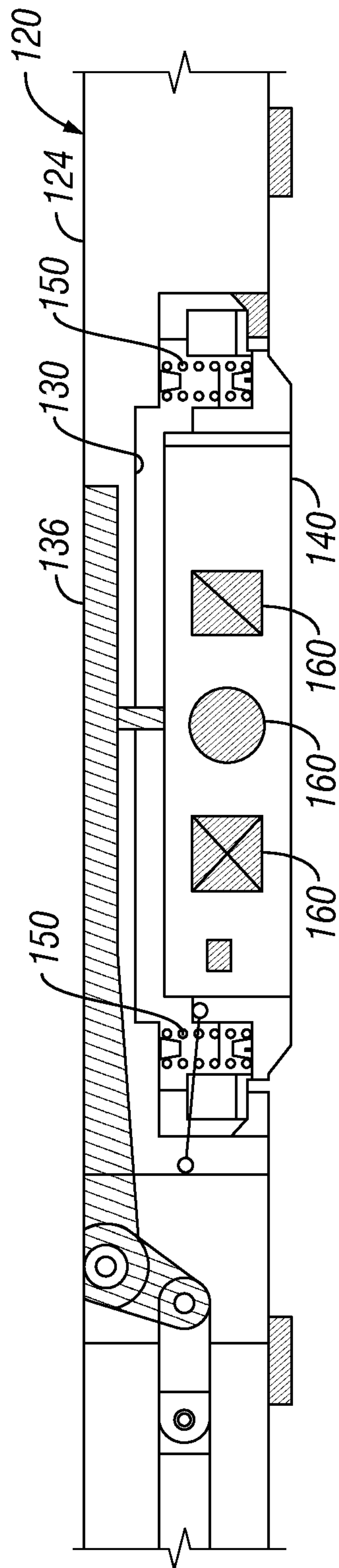
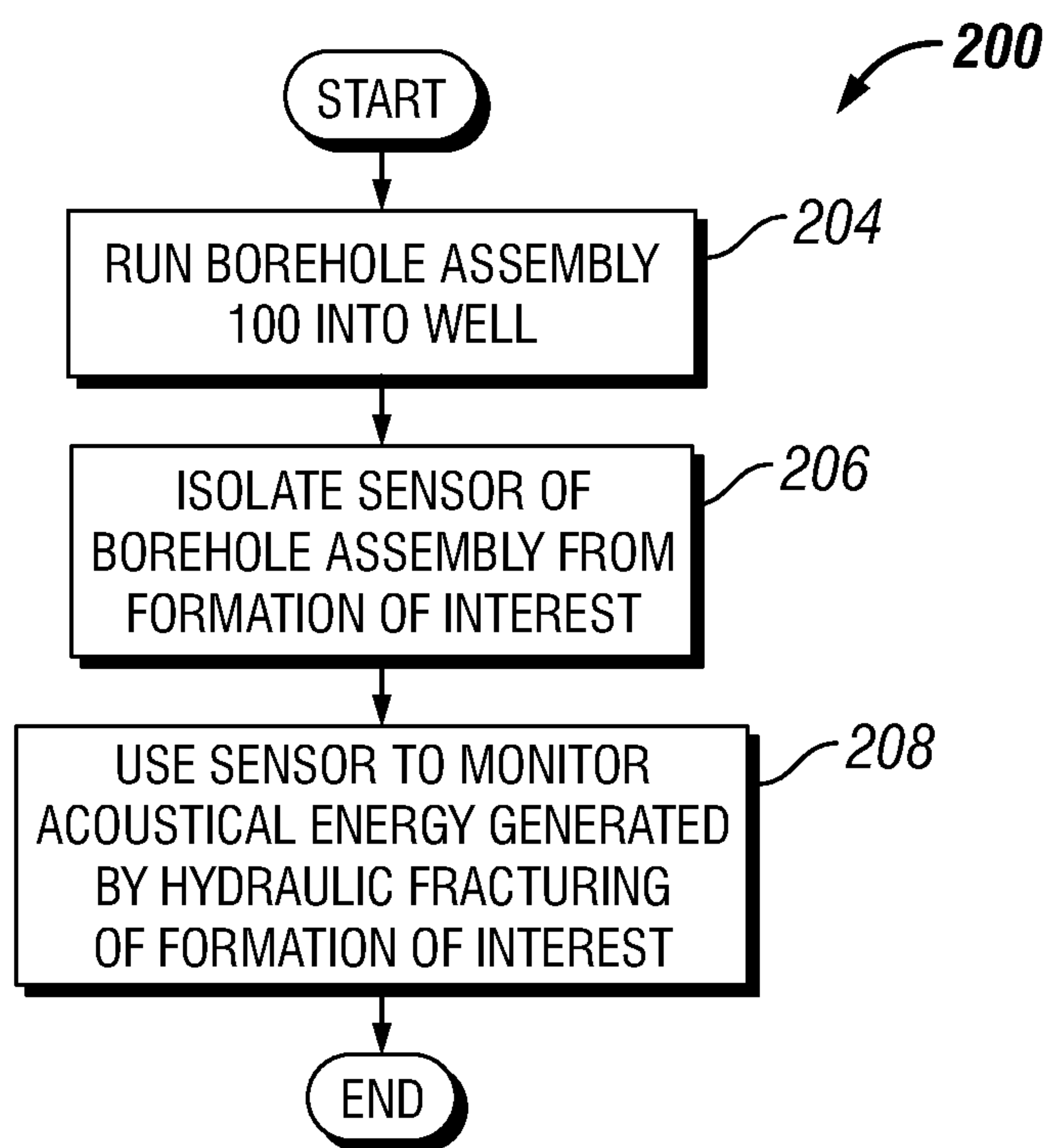

FIG. 2

**3/4****FIG. 3**

4/4

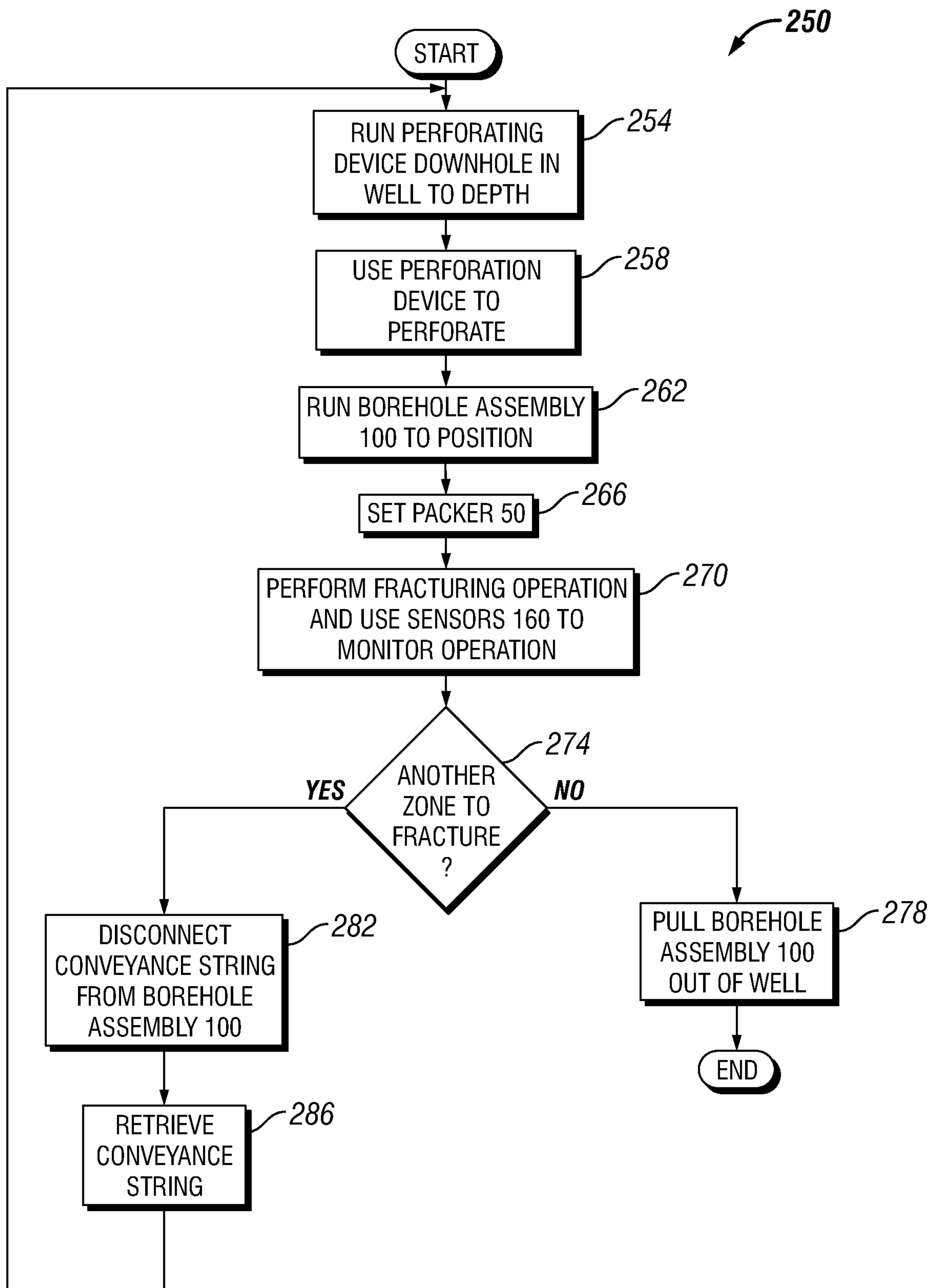

FIG. 4

