

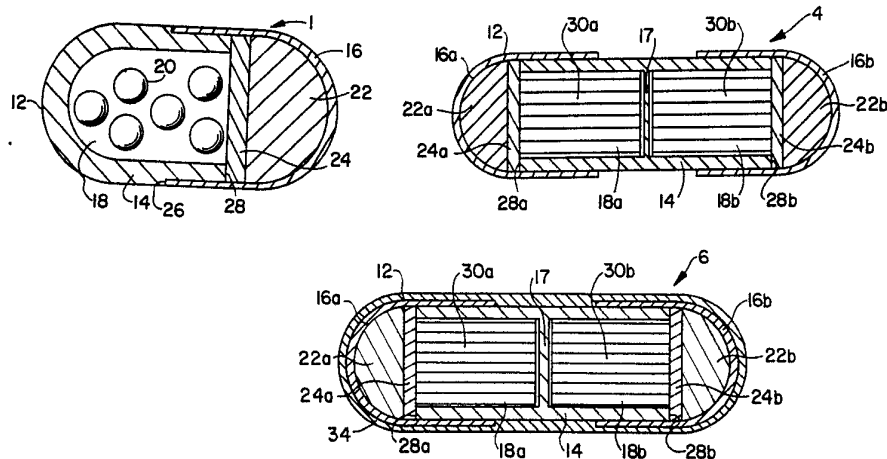

INTERNATIONAL APPLICATION PUBLISHED UNDER THE PATENT COOPERATION TREATY (PCT)

<p>(51) International Patent Classification ⁵ : A61K 9/00</p>	<p>A1</p>	<p>(11) International Publication Number: WO 92/13521 (43) International Publication Date: 20 August 1992 (20.08.92)</p>
<p>(21) International Application Number: PCT/US92/00635 (22) International Filing Date: 27 January 1992 (27.01.92) (30) Priority data: 648,270 30 January 1991 (30.01.91) US (71) Applicant: ALZA CORPORATION [US/US]; 950 Page Mill Road, Palo Alto, CA 94303-0802 (US). (72) Inventors: WONG, Patrick, S.-L. ; 2030 Cornell Street, Palo Alto, CA 94306 (US). THEEUWES, Felix ; 1634 Fallen Leaf Lane, Los Altos, CA 94022 (US). LARSEN, Steven, D. ; 11732 Betlen Drive, Dublin, CA 94568 (US).</p>		<p>(74) Agents: LARSON, Jacqueline, S. et al.; Alza Corporation, A2W, 950 Page Mill Road, P.O. Box 10950, Palo Alto, CA 94303-0802 (US). (81) Designated States: AT (European patent), AU, BE (European patent), CA, CH (European patent), DE (European patent), DK (European patent), ES (European patent), FI, FR (European patent), GB (European patent), GR (European patent), IT (European patent), JP, KR, LU (European patent), MC (European patent), NL (European patent), NO, SE (European patent). Published <i>With international search report.</i></p>

(54) Title: OSMOTIC DEVICE FOR DELAYED DELIVERY OF AGENT



(57) Abstract

The present invention is directed to a fluid-imbibing dispensing device (1) for the initially delayed delivery of an active agent (20) to a fluid environment of use and to a method of using the dispensing device. The dispenser comprises a housing (12) having a first wall section (14) and a second wall section (16) in slidably telescoping arrangement with each other, which housing (12) maintains its integrity in the environment of use; an internal compartment (18) surrounded and defined by the housing (12); at least one active agent formulation (20) in the compartment; and an expansion means (22) and a partition layer (24) in the compartment for separating apart the first and second wall sections (14, 16) of the housing (12) after exposure to the environment of use to expose the active agent formulations (20) to the environment of use.

FOR THE PURPOSES OF INFORMATION ONLY

Codes used to identify States party to the PCT on the front pages of pamphlets publishing international applications under the PCT.

AT	Austria	FI	Finland	MI	Mali
AU	Australia	FR	France	MN	Mongolia
BB	Barbados	GA	Gabon	MR	Mauritania
BE	Belgium	GB	United Kingdom	MW	Malawi
BF	Burkina Faso	GN	Guinea	NI	Netherlands
BG	Bulgaria	GR	Greece	NO	Norway
BJ	Benin	HU	Hungary	PL	Poland
BR	Brazil	IE	Ireland	RO	Romania
CA	Canada	IT	Italy	RU	Russian Federation
CF	Central African Republic	JP	Japan	SD	Sudan
CG	Congo	KP	Democratic People's Republic of Korea	SE	Sweden
CH	Switzerland	KR	Republic of Korea	SN	Senegal
CI	Côte d'Ivoire	LI	Liechtenstein	SU	Soviet Union
CM	Cameroon	LK	Sri Lanka	TD	Chad
CS	Czechoslovakia	LU	Luxembourg	TG	Togo
DE	Germany	MC	Monaco	US	United States of America
DK	Denmark	MG	Madagascar		
ES	Spain				

OSMOTIC DEVICE FOR DELAYED DELIVERY OF AGENT

FIELD OF THE INVENTION

The present invention is related to the delayed delivery of an active agent. More particularly, it is related to osmotically-activated devices for dispensing active agents to a biological environment of use following an initial delay.

BACKGROUND OF THE INVENTION

Osmotic dispensing devices for delivery of therapeutically active agents are well known in the art. Such devices use an expansion means to deliver an agent to an environment of use over a period of hours, days or months. The expansion means absorbs liquid, expands, and acts to drive out beneficial agent formulation from the interior of the device in a controlled, usually constant manner. The osmotic expansion means is used to controllably, usually relatively slowly, and over a period of time, deliver the agent. Thus, these devices are not generally used to delay the initial release of the agent, followed by the rapid release, or substantially simultaneous introduction, of all of the agent or all of the dosage form(s) containing the agent into the environment of use at one time.

The delay of the initial release of an agent has primarily been previously effected by coating the agent or a formulation containing the agent with a dissolvable or bioerodible coating layer, such as gelatin, which coating dissolves or erodes in the environment of use to then make the agent available. Delayed initial release has also been provided by dispersing the agent in a dissolvable or erodible matrix. However, such systems are often unreliable and release cannot be controlled with great accuracy due to the variability and relatively uncontrollable nature of erosion and dissolution.

Therefore, there remains a continuing need for improved methods and systems for providing a delayed initial delivery of an active agent to an environment of use that are reliable and that can be programmed to deliver the agent after a particular interval with increased accuracy.

SUMMARY OF THE INVENTION

The present invention is directed to a fluid-imbibing dispensing device for the initially delayed delivery of an active agent to a fluid environment of use. The dispenser comprises a housing having a first wall section and a second wall section in
5 slidably telescoping arrangement with each other, which housing maintains its integrity in the environment of use; an internal compartment surrounded and defined by the housing; at least one active agent formulation in the compartment, which formulation
10 includes at least one active agent; and an expansion means in the compartment for separating apart the first and second wall sections of the housing after exposure to the environment of use to expose the active agent formulation to the environment of use.

The invention also is directed to a method for delaying the
15 initial delivery of an active agent to a fluid environment of use, the method comprising placing the dispensing device of the invention into the environment of use, allowing fluid to be imbibed through at least a portion of the housing of the dispensing device for causing the expansion means to expand and exert pressure on the slidably
20 connected first and second wall sections, and delivering the active agent from the dispensing device by the expansion means increasing in volume, thereby pushing apart and separating the two wall sections of the device's housing and exposing the active agent formulation to the environment. During the delay period in the environment, the volume
25 of the reservoir containing the active agent is kept constant; therefore, there is a negligible pressure gradient between the environment and the interior of the reservoir. As a result, net flow of the environmental fluid driven by the pressure to enter the reservoir is minimal, so that the active agent is not contaminated or
30 diluted.

DESCRIPTION OF THE DRAWINGS

The drawings are not drawn to scale, but are set forth to illustrate various embodiments of the invention. Like numbers refer
35 to like structures.

FIG. 1 is a cross-sectional view of one embodiment of the present invention, the device being in closed or prepared form prior to placement in the environment of use.

FIG. 2 is the device of FIG. 1 in operation after activation by placement in the environment of use, showing the device opened to release the active agent formulation to the environment.

FIG. 3 is a cross-sectional view of the device of FIG. 1 but containing a different form of an active agent formulation.

FIG. 4 is a cross-sectional view of another embodiment of the present invention, in closed or prepared form.

FIG. 5 is a cross-sectional view of yet another embodiment of the present invention, directed to a multi-pulse dispensing device.

FIG. 6 is a cross-sectional view of an embodiment of the present invention directed to a multi-agent and/or multi-pulse dispensing device.

FIG. 7 is a cross-sectional view of an embodiment of the present invention which includes a loading dose for the initial rapid delivery of an agent.

FIG. 8 is a cross-sectional view of another embodiment of the invention which includes a loading dose of agent.

FIG. 9 is a cross-sectional view of a further embodiment of the present invention where one active agent is to be delivered in a controlled manner over a prolonged period of time and a second active agent is to be delivered after an initial delay period, the device being in closed form prior to placement in the environment of use.

FIG. 10 is a cross-sectional view of the embodiment of FIG. 9, after activation, at a point in time when the device is opened to release the second active agent.

FIG. 11 is a partial cross-sectional view of another embodiment of the invention, having a first wall section of two longitudinal halves.

FIGS. 12a and 12b are views through the first wall section of the embodiment of FIG. 11 along line A-A.

35

DETAILED DESCRIPTION OF THE INVENTION

The present invention provides a device which is useful for the initial delayed delivery of an active agent formulation to a fluid

environment of use, the delivery of the agent formulation from the dispensing device, once begun, being quickly completed rather than being continued over a prolonged period of time. By "prolonged period of time" is meant an extended time period such as for several
5 hours, days, weeks or months. In the present invention, in contrast, the delivery device is designed to substantially simultaneously introduce all of the active agent formulation, which formulation can be either an immediate release dosage form or a controlled release dosage form, to exposure to the environment of use substantially at
10 one time after the initial period of delay.

As used herein, the terms "therapeutically effective" amount or rate refer to the amount or rate of the active agent needed to effect the desired therapeutic, often beneficial, result.

The dispensing devices of the invention find use, for example,
15 in humans or other animals. The environment of use is a fluid environment and can comprise the stomach, the intestinal tract, or a body cavity such as the peritoneum or vagina. A single dispensing device or several dispensing devices can be administered to a subject during a therapeutic program.

20 FIG. 1 depicts in cross-sectional view a presently preferred embodiment of the delivery device according to the present invention. The device is shown in closed or prepared form prior to placement in the environment of use. Dispensing device 1 comprises a housing 12 formed of a first wall section 14 and a second wall section 16.
25 First wall section 14 and second wall section 16 are in slidably telescoping arrangement with each other. Housing 12 surrounds and defines an internal compartment 18. First wall section 14 surrounds that portion of internal compartment 18 that contains an active agent formulation, in this embodiment the formulation being a plurality of
30 active agent dosage forms 20. Second wall section 16 surrounds that portion of internal compartment 18 that contains an expansion means 22 for expanding and for occupying space in compartment 18. Second wall section 16 also contains a partition layer 24, which layer 24 is positioned between the agent formulation 20 and the expansion means
35 22. Partition layer 24, in a presently preferred embodiment, comprises a composition that is substantially impermeable to the passage of fluid, and it serves to restrict the passage of fluid

present in the expansion means into that area of compartment 18 that contains the agent formulation. It operates to essentially maintain the integrity of the active agent formulation and the expansion means layer. Additionally, and importantly, partition layer 24 acts to insure that the expanding driving force generated by the expansion means 22 is applied directly against the first wall section 14 to effect the separation of the two wall sections. Thus, partition layer 24 must be of sufficient strength, thickness and rigidity to transfer the driving force against first wall section 14.

10 First wall section 14 has an open end with a recessed outer edge for forming receiving means 26 for slidably receiving and engaging the open end of second wall section 16. The two wall sections at their open ends are close in size and they form a friction fit therebetween. The friction generated is sufficient to maintain the two wall sections together prior to activation of the expansion means but not so great as to keep the two wall sections from sliding apart once an expanding driving force is exerted. First wall section 14 and second wall section 16 can be telescoped completely into a closed and continuous external walled position. 15 The open end of first wall section 14 is adapted to fit within second wall section 16. The bottom edge of the open end of first wall section 14 provides a platform or ridge 28 protruding into compartment 18. Ridge 28 is adapted to receive the driving force of the expansion means 22, via the partition layer 24, to effect the separation of the two wall sections. 20 25

In operation, as the expansion means 22 absorbs and imbibes fluid through second wall section 16 from the environment of use, it expands and pushes against partition layer 24, causing the partition layer to slide inside compartment 18. Partition layer 24 moves toward and contacts ridge 28, pushing against ridge 28 and thus against first wall section 14 to cause the first wall section to slide apart from second wall section 16 as the expansion means 22 continues to expand. This causes the two wall sections to become separated and the active agent formulations 20 to be exposed to the environment of use, as illustrated in FIG. 2. 30 35

FIG. 2 illustrates the dispensing device 1 of FIG. 1 in operation after activation of the device by placement in the

environment of use. FIG. 2 shows device 1 opened to release all of the active agent dosage forms 20 to the environment substantially at the same time. First wall section 14 has been separated from second wall section 16 by the expanding driving force of the expansion means 22, which has expanded in size as a result of imbibing fluid from the environment. The arrows in FIG. 2 indicate the exiting of the agent formulation dosage forms 20 from internal compartment 18 through the open end of first wall section 14, which is now in communication with the environment.

First wall section 14 may comprise a composition that is semipermeable, that is, it is permeable to fluid but impermeable to active agent and other ingredients contained in dispensing device 1, or it may, alternatively, comprise a composition that is impermeable to the exchange of fluid, agent and other ingredients. When an active agent or an active agent dosage form is sensitive to fluid from an exterior fluid present in the environment of use, it is preferred that first wall section 14 be substantially impermeable to the ingress of the external fluid to serve as a means for substantially protecting the agent or dosage form.

Because expansion means 22 operates by the imbibition of external fluid, second wall section 16 in at least a portion that is adjacent to expansion means 22 must be permeable or semipermeable; that is, it is permeable to the passage of fluid while being substantially impermeable to the passage of other ingredients contained in dispensing device 1.

Wall sections 14 and 16 optionally comprise additional ingredients such as, for example, a plasticizer. Impermeable and semipermeable compositions suitable for use in wall sections 14 or 16, as well as suitable additives, are known in the art, examples of which are disclosed in U.S. Pat. 4,874,388, the entire disclosure of which is incorporated herein by reference.

Housing 12, comprising wall sections 14 and 16, is nontoxic, biologically inert, nonallergenic and nonirritating to body tissue, and it maintains its physical and chemical integrity; that is, housing 12 does not erode or degrade in the environment of use during the dispensing period. It is within the scope of the invention that the housing be insoluble only during the period of intended use and

can thereafter dissolve away in the environment of the device. Thus, a dispenser is here contemplated which is unaffected by its environment, solubility-wise, at the situs of use or which, alternatively, is only slightly soluble during the period of intended use, such that once its active agent content has been removed it will then dissolve or erode away leaving no objectionable residue or empty container at the situs of use.

The expansion means or expandable driving means 22, operable for separating the first and second wall sections to release the active agent from the dispensing device of the invention, is nontoxic, nonallergenic and biologically inert. Expansion means 22 comprises, in one presently preferred embodiment, an osmopolymer. The osmopolymers interact with water and aqueous biological fluids and swell or expand to an equilibrium state. The osmopolymers exhibit the ability to swell in fluid and to retain a significant portion of the imbibed and absorbed fluid within the polymer structure. The expansion means 22 in another preferred embodiment comprises an osmagent. The osmagents are known also as osmotically effective solutes and they are also known as osmotically effective compounds. The osmagents that can be used for the purpose of this invention include inorganic and organic compounds that exhibit an osmotic pressure gradient across a semipermeable, i.e. a fluid-permeable, wall. The expansion means 22 in yet another preferred embodiment comprises an osmagent dispersed within an osmopolymer. The expansion means 22 can comprise a tablet or a layer, or a plurality of tablets or layers, or it can be pressed into second wall section 16. The osmagent or osmopolymer can be in any suitable form such as particles, crystals, pellets, granules, and the like, when pressed into a tablet layer and into wall section 16. Osmagents and osmopolymers are known to the art and are described in, for example, U.S. Pat. Nos. 3,865,108, 4,002,173, 4,207,893, 4,327,725 and 4,612,008.

Partition layer 24, present in certain embodiments of the invention between the active agent formulation and the expansion means, is a means for transmitting the force generated by the expansion means against the first wall section 14, for maintaining the separate identity of the active agent formulation and the

expansion means, and for substantially restricting the passage of fluid between the active agent formulation and the expansion means. Representative materials useful as a partition layer 24 are known to the art in, for example, U.S. Pat. No. 4,874,388.

5 The term "active agent formulation", as used herein, comprises the active agent to be delivered, as a liquid, solid, semisolid or thermo-sensitive composition, generally in a carrier substance and with or without additional inert ingredients. The term may additionally include dosage forms comprising the active agent which are capable of maintaining their physical configuration and chemical
10 integrity while housed within the dispenser. These include, without limitation, tablets with or without a density element; matrix tablets; spheres; pellets and elongated tablets; capsules; elementary osmotic pumps, such as those described in U.S. Pat. No. 3,845,770; mini-osmotic pumps, such as those described in U.S. Pat.
15 Nos. 3,995,631, 4,034,756 and 4,111,202; and multi-chamber osmotic systems referred to as push-pull and push-melt osmotic pumps, such as those described in U.S. Pat. Nos. 4,320,759 and 4,449,983; all the above patents of which are incorporated herein by reference.

20 The pharmaceutically acceptable carrier useful herein may comprise more than one ingredient, such as, for example, a buffer, a viscosity regulating vehicle, a surfactant, dyes, a permeation enhancer, proteinase inhibitors, or other formulation ingredients and additives, as are known in the art. The carrier may contain more
25 than one active agent. The active agent formulation can erode or disintegrate and can be in the form of a wax formulation, solid core or tablet, for example. The formulation can immediately dissolve upon exposure to fluid or it may erode slowly with or without the presence of excipients for controlling erosion.

30 The active agent formulation can be designed in a multitude of ways to provide a specific drug delivery profile. One embodiment may comprise a formulation that contains a biologically acceptable solid surfactant which is capable of slow dispersion in the environmental fluid. In another embodiment, the formulation may contain a fluid-
35 insoluble wax and a surfactant so that the formulation is susceptible to erosion in the environment. In still another embodiment, the formulation may be effervescent and provide drug delivery in a finely

dispersed form. This is accomplished by the addition of a solid basic compound capable of evolving carbon dioxide in the presence of an acid in the environment of use. Suitable basic compounds are disclosed in U.S. Pat. No. 4,265,874. In a further embodiment, the formulation may include an osmotic agent or solute, such as those described above with reference to the expansion means 22, so that when the formulation comes into contact with the environmental fluid, it immediately dissolves. In yet another embodiment, the agent formulation can be comprised of an agent and a thermo-responsive composition. In this manner, the formulation would exhibit solid-like properties at room temperature of 21°C and within a few degrees Celsius thereof, and would have a melting point that approximates mammalian body temperatures of 37°C and within a few degrees Celsius thereof. The term "thermo-responsive" as used herein, in a preferred embodiment denotes the physical-chemical property of an agent carrier composition to exhibit solid, or solid-like properties at temperatures up to 31°C and become fluid, semi-solid or viscous when disturbed by heat at temperatures from 31°C, usually in the range of 31°C to 45°C. Suitable materials useful as active agent carriers and excipients are known in the art and are disclosed in U.S. Pat. Nos. 4,595,583 and 4,874,388, for example.

The terms "active agent" and "drug" are used interchangeably herein and refer to an agent, drug, compound, composition of matter or mixture thereof which provides some therapeutic, often beneficial, effect. This includes pesticides, herbicides, germicides, biocides, algicides, rodenticides, fungicides, insecticides, anti-oxidants, plant growth promoters, plant growth inhibitors, preservatives, anti-preservatives, disinfectants, sterilization agents, catalysts, chemical reactants, fermentation agents, foods, food supplements, nutrients, cosmetics, drugs, vitamins, sex sterilants, fertility inhibitors, fertility promoters, microorganism attenuators and other agents that benefit the environment of use. As used herein, the terms further include any physiologically or pharmacologically active substance that produces a localized or systemic effect or effects in animals, including warm blooded mammals, humans and primates; avians; domestic household or farm animals such as cats, dogs, sheep, goats, cattle, horses and pigs; laboratory animals such as

mice, rats and guinea pigs; fish; reptiles; zoo and wild animals; and the like. The active drug that can be delivered includes inorganic and organic compounds, including, without limitation, drugs which act on the peripheral nerves, adrenergic receptors, cholinergic receptors, the skeletal muscles, the cardiovascular system, smooth muscles, the blood circulatory system, synoptic sites, neuroeffector junctional sites, endocrine and hormone systems, the immunological system, the reproductive system, the skeletal system, autocoid systems, the alimentary and excretory systems, the histamine system and the central nervous system. Suitable agents may be selected from, for example, proteins, enzymes, hormones, polynucleotides, nucleoproteins, polysaccharides, glycoproteins, M. lipoproteins, polypeptides, steroids, hypnotics and sedatives, psychic energizers, tranquilizers, anticonvulsants, muscle relaxants, anti-Parkinson agents, analgesics, anti-inflammatories, local anesthetics, muscle contractants, antimicrobials, antimalarials, hormonal agents including contraceptives, sympathomimetics, polypeptides and proteins capable of eliciting physiological effects, diuretics, lipid regulating agents, antiandrogenic agents, antiparasitics, neoplastics, antineoplastics, hypoglycemics, nutritional agents and supplements, growth supplements, fats, ophthalmics, anti-enteritis agents, electrolytes and diagnostic agents.

Examples of beneficial agents which this invention can be utilized with are prochlorperazine edisylate, ferrous sulfate, aminocaproic acid, mecamlamine hydrochloride, procainamide hydrochloride, amphetamine sulfate, methamphetamine hydrochloride, benzphetamine hydrochloride, isoproterenol sulfate, phenmetrazine hydrochloride, bethanechol chloride, methacholine chloride, pilocarpine hydrochloride, atropine sulfate, scopolamine bromide, isopropamide iodide, tridihexethyl chloride, phenformin hydrochloride, methylphenidate hydrochloride, theophylline cholineate, cephalexin hydrochloride, diphenidol, meclizine hydrochloride, prochlorperazine maleate, phenoxybenzamine, thiethylperazine maleate, anisindione, diphenadione erythrityl tetranitrate, digoxin, isofluorophate, acetazolamide, methazolamide, bendroflumethiazide, chlorpropamide, tolazamide, chlormadinone acetate, phenaglycodol, allopurinol, aluminum aspirin, methotrexate, acetyl sulfisoxazole,

erythromycin, hydrocortisone, hydrocorticosterone acetate, cortisone acetate, dexamethasone and its derivatives such as betamethasone, triamcinolone, methyltestosterone, 17 β -estradiol, ethinyl estradiol, ethinyl estradiol 3-methyl ether, prednisolone,

5 17 β -hydroxyprogesterone acetate, 19-nor-progesterone, norgestrel, norethindrone, norethisterone, norethiederone, progesterone, norgesterone, norethynodrel, aspirin, indomethacin, naproxen, fenoprofen, sulindac, indoprofen, nitroglycerin, isosorbide dinitrate, propranolol, timolol, atenolol, alprenolol, cimetidine,

10 clonidine, imipramine, levodopa, chlorpromazine, methyl dopa, dihydroxyphenylalanine, theophylline, calcium gluconate, ketoprofen, ibuprofen, cephalixin, erythromycin, haloperidol, zomepirac, ferrous lactate, vincamine, diazepam, phenoxybenzamine, diltiazem, milrinone, captopril, mandol, quanbenz, hydrochlorothiazide, ranitidine,

15 flurbiprofen, fenbufen, fluprofen, tolmetin, alclofenac, mefenamic, flufenamic, difuninal, nimodipine, nitrendipine, nisoldipine, nifedipine, felodipine, lidoflazine, tiapamil, gallopamil, amlodipine, mioflazine, lisinopril, enalapril, captopril, ramipril, endlapriat, famotidine, nizatidine, sucralfate, etintidine,

20 tetratolol, minoxidil, chlordiazepoxide, diazepam, amitriptyline, and imipramine. Further examples are proteins and peptides which include, but are not limited to, insulin, colchicine, glucagon, thyroid stimulating hormone, parathyroid and pituitary hormones, calcitonin, renin, prolactin, corticotrophin, thyrotropic hormone,

25 follicle stimulating hormone, chorionic gonadotropin; gonadotropin releasing hormone, bovine somatotropin, porcine somatotropin, oxytocin, vasopressin, prolactin, somatostatin, lypressin, pancreozymin, luteinizing hormone, LHRH, interferons, interleukins, growth hormones such as human growth hormone, bovine growth hormone and porcine

30 growth hormone, fertility inhibitors such as the prostaglandins, fertility promoters, growth factors, and human pancreas hormone releasing factor.

It is to be understood that more than one active agent may be incorporated into the active agent formulation in a device of this invention, and that the use of the term "agent" or "drug" in no way

35 excludes the use of two or more such agents or drugs.

The agents can be in a wide variety of chemical and physical forms, such as uncharged molecules, components of molecular complexes or nonirritating, pharmacologically acceptable salts. Also, simple derivatives of the agents (such as ethers, esters, amides, etc.) which are easily hydrolyzed by body pH, enzymes, etc., can be employed.

The amount of active agent employed in the delivery device will be that amount necessary to deliver a therapeutically effective amount of the agent to achieve the desired result at the site of delivery. In practice, this will vary widely depending upon the particular agent, the site of delivery, the severity of the condition, and the desired therapeutic effect. Thus, it is not practical to define a particular range for the therapeutically effective amount of active agent incorporated into the device.

FIG. 3 illustrates another embodiment of the dispensing device 1 of the present invention. As illustrated in this figure, dispensing device 1 is similar to the dispensing device of FIGS. 1 and 2, having a housing 12, a first wall section 14, a second wall section 16, an internal compartment 18 surrounded and defined by housing 12, expansion means 22, partition layer 24, receiving means 26 and ridge 28, but contains an active agent formulation 30 that is of a different form than that of FIGS. 1 and 2. Active agent formulation 30 is present as a single homogeneous or heterogeneous mass and may be in solid, liquid or semi-solid form or may comprise a thermo-sensitive composition. Agent formulation 30 may comprise a pharmaceutically acceptable carrier in addition to the active agent, with the agent being dispersed homogeneously or heterogeneously within the carrier.

FIG. 4 illustrates another embodiment of the dispensing device of the present invention. Dispensing device 2 comprises a housing 12 formed of a first wall section 14 and a second wall section 16. First wall section 14 and second wall section 16 are in slidably telescoping arrangement with each other. Housing 12 surrounds and defines an internal compartment 18. Internal compartment 18 contains an active agent formulation, in this embodiment the formulation being a plurality of active agent dosage forms 20. Alternatively, the active agent formulation could be present as solid, semi-solid or

liquid particles of active agent formulation dispersed in compartment 18. Internal compartment 18 also contains an expansion means 22 within a portion and, preferably, within substantially all of compartment 18 for expanding and for occupying space in the compartment. The active agent formulation may be dispersed throughout the expansion means 22 within compartment 18. At least one, and preferably both of first wall section 14 and second wall section 16 are comprised in at least a portion of a semipermeable composition so that fluid may be imbibed into the compartment to activate expansion means 22. As expansion means 22 takes up fluid and expands, a high internal pressure is created and the resulting driving force is exerted against the closed ends of the wall sections 14 and 16, causing the open ends of the two wall sections, which are held together by a friction fit therebetween, to slide apart and become separated, releasing active agent dosage forms 20 into the environment of use.

A multi-pulse delivery of active agent formulation over an extended period of time, such as 24 hours, may be provided by utilizing sequentially smaller dispensing devices of the invention enclosed within each other. Such a multi-pulse dispenser is illustrated in FIG. 5. In FIG. 5, multi-pulse dispensing device 3 is comprised of a plurality of housings 12a, 12b and 12c, each smaller than the other and contained within the internal compartment of the next larger housing. Thus, housing 12c is contained within internal compartment 18b of housing 12b, and housing 12b (containing housing 12c) is itself contained within internal compartment 18a of housing 12a. Also contained within each of the compartments 18a, 18b and 18c are active agent formulation dosage forms 20a, 20b and 20c, respectively, dispersed in expansion means 22a, 22b and 22c, respectively. As housing 12a is opened by the expanding driving force of expansion means 22a, it releases housing 12b into the environment of use as it releases active agent dosage forms 20a. Housing 12b is then exposed to the environmental fluid and is opened after a delay period by the expanding driving force of expansion means 22b, releasing active agent dosage forms 20b together with housing 12c. Housing 12c in its turn is then exposed to the

environmental fluid to release active agent dosage forms 20c by expansion of means 22c.

FIG. 6 illustrates an embodiment of the invention where two active agents are delivered from the same device. Such a dispensing device is desirable when, for example, the agents must be kept
5 separated because they are physically or chemically incompatible with each other or when the agents are to be delivered to the environment at different points in time. Dispensing device 4 comprises a housing 12 formed of a first wall section 14 and two second wall sections 16a
10 and 16b. First wall section 14 has two opposing open ends and includes an impermeable internal dividing wall 17 which divides the space encompassed by housing 12 into two internal compartments 18a and 18b. That part of first wall section 14 encompassed by one of its two open ends and dividing wall 17 surrounds that portion of
15 internal compartment 18a that contains an active agent formulation 30a. That part of first wall section 14 encompassed by the other of its two open ends and dividing wall 17 surrounds that portion of internal compartment 18b that contains an active agent formulation 30b. Formulations 30a and 30b may comprise the same active agent or
20 different active agents. The two formulations may be the same or different; for example, they may both be liquids, or one may be solid and one liquid, or one may be a liquid and the other a plurality of dosage forms. Formulations 30a and 30b may comprise the same active agent but in two different chemical forms, such as the
25 base drug and a salt of the same drug.

Second wall section 16a of dispensing device 4 surrounds that portion of internal compartment 18a that contains an expansion means 22a for expanding and for occupying space in compartment 18a. Second wall section 16a also contains a partition layer 24a, which layer 24a
30 is positioned between the agent formulation 30a and the expansion means 22a. Second wall section 16b surrounds that portion of internal compartment 18b that contains an expansion means 22b for expanding and for occupying space in compartment 18b. Second wall section 16b also contains a partition layer 24b, which layer 24b is
35 positioned between the agent formulation 30b and the expansion means 22b. The bottom edge of each of the open ends of first wall section 14 provides a platform or ridge 28a and 28b protruding into

compartments 18a and 18b, respectively, for receiving the driving force of the expansion means via partition layers 24a and 24b, respectively, to separate apart the first wall section and the second wall sections.

5 Where it is desired to deliver active agent formulations 30a and 30b substantially concurrently, the composition of expansion means 22a and 22b will be the same so that they will have identical expansion profiles, to separate the first wall section from both
10 second wall sections at substantially the same time. Where it is desired, on the other hand, to deliver active agent formulations 30a and 30b at different points in time, that is, after different initial delay periods (a multi-pulse system), the composition of the two expansion means will be different in order to provide the different initial delay periods.

15 Another embodiment of the invention is very similar to that illustrated in FIG. 6 except that it does not include an impermeable internal dividing wall 17. Thus, the delivery device of this similar embodiment comprises a housing 12 formed of a first wall section 14 and two second wall sections 16a and 16b, expansion means 22a and
20 22b, partition layers 24a and 24b, and ridges 28a and 28b. First wall section 14 has two opposing open ends and encompasses one internal compartment 18, which compartment 18 contains one active agent formulation 30 or a plurality of dosage forms 20. This double-capped embodiment is useful when it is desired to expedite the
25 release of the active agent formulation 30 or 20 from the device once the agent formulation is exposed to the environment of use. In such a use, the composition of expansion means 22a and 22b will normally be the same so that the expansion means will separate the first wall section from the two second wall sections at substantially the same
30 time to release the active agent formulation 30 or 20.

 It may, in certain instances, be desirable to provide an initial rapid delivery of an active agent to the environment of use in addition to the delayed delivery of active agent provided by this invention. Such initial agent delivery may be accomplished by means
35 for providing an initial agent dose. FIG. 7 illustrates one means of initial agent delivery. In FIG. 7, dispensing device 5 comprises housing 12 having a first wall section 14 and a second wall section

16, internal compartment 18, active agent formulation dosage forms 20, expansion means 22, partition layer 24, receiving means 26 and ridge 28. Dispensing device 5 additionally comprises an initial agent delivery means or loading dose 32. Loading dose 32 comprises at least one active agent homogeneously or heterogeneously dispersed or dissolved in an appropriate carrier means, which can be a solid, paste, gel, semisolid, or the like, or a thermo-sensitive material which provides a dispensable material in the environment of use. The loading dose 32 can be in the form of a tablet or capsule, for example, and can be round, spheroid, toroid, cylindrical, square, and the like. Loading dose 32 is located on or within dispensing device 5 in such a manner that, upon application of the device to the environment of use, the loading dose is immediately exposed to the environment. This may be accomplished by means of a retaining device such as a ridge (as illustrated by retaining ridge 46) or a screen, for example. Once device 5 is placed in the environment of use, loading dose 32 dissolves, erodes, osmotically bursts or otherwise begins to dispense the active agent contained therein. At the same time, expansion means 22 will begin to imbibe fluid, expanding to begin to separate first wall section 14 and second wall section 16. This provides a pulsed delivery of agent from loading dose 32 at a first time period and of agent from the agent dosage forms 20 at a second time period. The formulation of the loading dose 32 can be so designed that the delivery of the initial agent could be completed prior to the delivery of the dosage forms 20 or, alternatively, that the initial agent could provide a continuous delivery for a period up to and even after the delivery of the dosage forms. The loading dose and the agent dosage forms may contain the same active agent or different active agents.

Delivery of an initial agent dose may also be accomplished by coating housing 12 externally with an overcoat or loading dose containing an active agent, as is illustrated in FIG. 8. In FIG. 8, dispensing device 6 is the same as device 4 of FIG. 6, except that device 6 also comprises an overcoat or loading dose 34 that surrounds housing 12. Once placed in the environment of use, loading dose 34 will begin immediately to dissolve, erode or otherwise dispense an active agent contained in the loading dose. In this embodiment, the

expansion means 22a and 22b of the device cannot begin to imbibe water and become activated until such time as the loading dose 34 has dissolved or eroded away from the semipermeable membranes of second wall sections 16a and 16b, so that a good portion if not all of the active agent in the loading dose will have been dispersed prior to the dispersion of the agent in active agent formulations 30a and/or 30b, thus providing a multi- (two- or three-) pulse delivery of agent.

FIGS. 9 and 10 are cross-sectional views of another embodiment of the dispensing device of the present invention, prior to delivery (FIG. 9) and subsequent to delivery (FIG. 10) of the device to an environment of use. Dispensing device 7 comprises a housing 12 formed by a first wall section 14 and a second wall section 16, the two wall sections being in slidably telescoping arrangement and enclosing an internal compartment 18. That portion of compartment 18 enclosed by first wall section 14 contains a first expansion means 34 and a first active agent formulation 36, which in a preferred embodiment are separated by a moveable impermeable first partition layer 38 to maintain the separate identities of the first agent formulation 36 and the first expansion means 34. It also contains a second active agent formulation 30 and an impermeable barrier layer 40 which separates first expansion means 34 from second active agent formulation 30. Barrier layer 40 is preferably non-moveable in the device. First wall section 14 also comprises an exit means or port 42 which provides communication between the environment of use and that part of internal compartment 18 containing first active agent formulation 36.

The exit means or port may comprise one orifice or a plurality of orifices and is formed by conventional techniques described in the literature. Included among these methods are mechanical drilling, laser drilling, and liquid techniques using an orifice-forming agent, such as erosion, extraction, dissolving, bursting or leaching, depending on the nature of the agent used. The first wall section 14 will contain at least one such orifice, and in most configurations, one orifice will suffice. The dimensions of the orifice in terms of both diameter and length will affect the rate at which the drug is released from the device in response to the pressure differential

resulting from the volumetric expansion of the first expansion means caused by the osmotic imbibition. The considerations involved in determining the optimum dimensions of the orifice for any particular device or drug are the same as those for orifices of osmotic devices of the prior art, and selection of the appropriate dimensions will be readily apparent to those skilled in the art.

That portion of compartment 18 enclosed by second wall section 16 contains a second expansion means 22 and a moveable impermeable second partition layer 24, the second partition layer 24 being between second expansion means 22 and second active agent formulation 30 and positioned to come into contact with the end or ridge 28 of the open end of first wall section 14.

At least that portion of first wall section 14 adjacent to first expansion means 34 must be of a semipermeable composition, since the expansion means is activated by the imbibition of water. Likewise, second wall section 16 is of semipermeable composition. When first wall section 14 is semipermeable adjacent to second active agent formulation 30, an impermeable inner wall 44 may be present between first wall section 14 and agent formulation 30 when it is desired to protect the active agent from fluid from the environment. Such an additional impermeable wall may also be present between wall section 14 and first active agent formulation 36 when it is desired to protect the active agent in formulation 36 from fluid from the environment.

In practice, as fluid is imbibed by first expansion means 34, the expanding driving force of means 34 is conveyed via first partition layer 38 against the first active agent formulation 36, and agent formulation 36 is then immediately begun to be expelled in a controlled and continuous manner from internal compartment 18 through exit port 42 into the environment of use, providing an initial active agent dose. At the same time, second expansion means 22 begins to expand and exert a driving force via second partition layer 24 against end or ridge 28 of first wall section 14 to begin to slidably separate first wall section 14 from second wall section 16. Second agent formulation 30 is only delivered to the environment of use at the point in time when first wall section 14 and second wall section 16 have separated apart from each other. In such a manner, first

agent formulation 36 is continuously delivered to the environment while a pulse of second agent formulation 30 is delivered at a later, delayed time. First agent formulation 36 and second agent formulation 30 may comprise the same active agent or different active agents or they may comprise the same active agent in different forms.

FIG. 11 illustrates, in partial cross-sectional view, a device 1 similar to the devices described in FIGS. 1-3 and having a housing 12 comprised of first wall section 14 and second wall section 16, an internal compartment 18 surrounded and defined by housing 12, a plurality of dosage forms 20, expansion means 22, partition layer 24, receiving means 26 and ridge 28. FIG. 11 illustrates an alternative embodiment of the present invention where the first wall section 14 is comprised of two longitudinal halves which contact each other at longitudinal junction 48. It is to be noted that, while two longitudinal portions are presented by way of illustration, the invention is not limited thereto, and second wall section 14 may be comprised of from one to four or more longitudinal portions. The two longitudinal halves are held together by the pressure exerted on them by that portion of the open end of second wall section 16 that overlaps the open end of first wall section 14. When the two wall sections are separated by the action of the expansion means 22, the two longitudinal halves of first wall section 14 become free of the restraining pressure of second wall section 16 so that the two longitudinal halves can then separate from each other to provide additional exposure of active agent formulation to, or to aid in the release of the active agent formulation to the environment of use.

As illustrated in FIGS. 12a and 12b, which are section views along line A-A of device 1 of FIG. 11, the longitudinal walls of the two halves of first wall section 14 may be so shaped as to provide an interlocking means 50 between the two halves at the longitudinal junction 48. The interlocking means 50 may be, for example, an interlocking ridge that runs continuously along the length of the longitudinal walls of the two halves (FIG. 12a) or a plurality of interlocking concave and convex structures positioned at corresponding points along the longitudinal walls of the two halves (FIG. 12b). The interlocking means 50 provides an additional

mechanism for maintaining the two longitudinal halves together while the device 1 is in closed form.

For proper delivery of the active agent, it may be desirable in some instances for the dispensing device to deliver active agent to a particular environment of use. Thus, it may be necessary for the device to remain in a particular environment of use until such time as the agent formulation has been delivered or, alternatively, for the device to pass through one particular environment to another prior to delivering agent formulation. In such cases, additional elements are included in the device, or the device is designed in such a way to provide for such particular delivery. For example, when the environment of use is the rumen of a ruminant animal, a density element may be included in the dispensing device so that the device is weighted to remain within the rumen during the dispensing period. Density elements are known in the art and are discussed in, for example, U.S. Pat. 4,874,388. When the environment of use is the human stomach, it may be desirable for the device, for example, to have a low initial density or to include air in that portion of the internal compartment of the device that also contains the agent formulation. In this manner, the device will float on the surface of the stomach contents and remain in the stomach until the device opens to release the formulation. Where it is desirable, on the other hand, to delay the release of an active agent which, for example, is inactivated by the stomach contents or may cause nausea or bleeding by irritating the gastric mucosa so that delivery in the stomach is not desired, an enteric coating can be applied over at least that portion of the housing of the dispensing device that is comprised of a semipermeable membrane. Enteric coatings will remain intact in the stomach but will rapidly dissolve once they arrive at the small intestine, thereafter allowing fluid to be imbibed to activate the dispensing device. Enteric coatings are well known in the art and are discussed at, for example, "Remington's Pharmaceutical Sciences", Mack Publishing Co., Easton, PA.

The total delay time prior to separation of the dispensing device and delivery of the active agent formulation can be controlled by a number of means. For example, the rate of fluid imbibition into the expansion means can be controlled by the particular choice of

semipermeable membrane. The rate of expansion of the expansion means can be controlled by the choice of composition of the expansion means. The distance of overlap between the open end portions of the first and second wall sections can determine the period of time
5 required for the two sections to separate. Combinations of such means may be used. Such control means are known in the art and can be determined without undue experimentation.

The above description has been given for ease of understanding only. No unnecessary limitations should be understood therefrom, as
10 modifications will be obvious to those skilled in the art.

The following examples are illustrative of the present invention. They are not to be construed as limitations of the scope of the invention. Variations and equivalents of these examples will be apparent to one skilled in the art in light of the present
15 disclosure, the drawings and the claims herein.

EXAMPLE 1

A delivery device according to the invention was prepared as follows.

20 The osmotic engine portion of the device is a compressed bilayer tablet composed of a 150 mg polymeric osmotic formulation (expansion means) and a 50 mg wax-based barrier.

The polymeric osmotic formulation has a composition of 60 wt% polyethylene oxide (Polyox® 303, Union Carbide), 29 wt% sodium
25 chloride, 5 wt% polyacrylic acid (Carbomer® 934P, B.F. Goodrich), 5 wt% hydroxypropylmethylcellulose E-5, and 1 wt% ferric oxide. During preparation, each of the above components was screened through a 40 mesh screen, and the sized components were added to a mixing vessel in the appropriate proportions. The dry components were mixed
30 thoroughly for 10 minutes; then, SDA 3A ethanol was slowly added while mixing continued until a wet mass had formed. The wet mass was then screened through a 20 mesh screen, and the wet granules were allowed to air dry for 18 hours. After drying, the granules were passed once more through a 20 mesh screen.

35 The wax barrier has a composition of 95 wt% microcrystalline wax (MF-2JH Durawax®, Astor Wax Corp.) and 5 wt% gelatin (Type A, 275-300 bloom). During preparation, each component was screened

through a 40 mesh screen before being added in the correct weight ratio to a mixing vessel. The dry materials were mixed thoroughly for 10 minutes; then, purified water was slowly added to the mixture while stirring continued. After a wet mass formed, the mixture was
5 passed through a 20 mesh screen, and the granules were oven-dried at 40°C for 24 hours. After the granules had dried, they were re-screened through a 20 mesh screen.

The osmotic formulation and the wax barrier formulation were compressed in a hydraulic or rotary press into a cylindrical bilayer
10 tablet. The osmotic face of the tablet was convex, to conform to the shape of the delivery device, while the barrier face of the tablet was flat. Tableting was conducted to produce a clean, distinct interface between the two layers.

To prepare the vessel portion (first wall section) of the
15 device, 70 wt% cellulose acetate 320 and 30 wt% polypropylene glycol were thoroughly mixed together and were then added to the hopper of a screw extruder. The polymeric mixture was heated at 127°C as it was extruded through the heated barrel of the extruder and into a mold for the vessel. The polymer mixture was allowed to cool after
20 injection into the mold, after which the vessel was removed from the opened mold.

The cap portion (second wall section) of the device was prepared in the same manner as the vessel, the composition of the cap being 70 wt% cellulose acetate 320 and 30 wt% polypropylene glycol.
25 The heated polymeric mixture was injected into a mold for the cap and allowed to cool, and the finished cap was then ejected.

To assemble the delivery device, the desired active agent formulation is placed into a completed vessel by manual or automated fill mechanisms. The osmotic engine bilayer tablet is placed into a
30 completed cap with the convex osmotic layer pointed into the closed end of the cap and the barrier layer exposed toward the cap opening. The open end of the filled vessel is fitted inside the open end of the cap, and the two pieces are compressed together until cap, osmotic bilayer tablet and vessel fit together tightly.

EXAMPLE 2

A delivery device was prepared as in Example 1, except that the polymeric osmotic formulation was 130 mg. The assembled device was then coated with approx. 20 mg of a methacrylic acid copolymer enteric coat (Eudragit® L 100-55, Röhm Pharma).

EXAMPLE 3

A delivery device according to the present invention was prepared as follows.

10 The cap (second wall section) was formed by coating a gelatin capsule with a cellulose acetate-based membrane in the following manner. A coating solution composed of 5 wt% cellulose acetate 398 and polyethylene glycol 3350 (in a 95/5 weight ratio) in a solution of acetone/ethanol (in a 90/10 weight ratio) was sprayed onto a size 15 "0" clear gelatin capsule in a Wurster coater. The capsule was coated to a membrane thickness of 3-4 mil. The capsule was then dried in a 50°C oven to remove residual solvent, after which the two parts of the capsule were separated with their respective membrane covering intact. The short segment of the coated capsule was 20 retained as the required cap, while the long segment was discarded.

The vessel (first wall section) was formed by machining a cylindrical container with one open end from polycarbonate polymer. The machined dimensions were such that the open end of the vessel will fit snugly within the coated gelatin cap.

25 To assemble the device, following the procedure of Example 1, the osmotic engine bilayer tablet from Example 1 was placed in the cap portion, the desired active agent formulation was placed in the vessel portion, the open end of the vessel portion was fitted into the open end of the cap portion, and the two pieces were compressed 30 together to obtain a tight fit.

Another device was prepared following the above procedures, except that during manufacture of the cap portion, the gelatin capsule was coated with a cellulose acetate/polyethylene glycol membrane of 8-9 mil thickness.

EXAMPLE 4

Delivery devices were prepared as in Example 3, except that the weight ratio of cellulose acetate to polyethylene glycol in the membrane covering the cap was 80/20.

EXAMPLE 5

Nine devices from Example 1, but not containing any active agent formulation, were assembled and placed in artificial intestinal fluid (USP XIX, intestinal fluid, simulated, TS; modified herein by not including enzymes) in a shaker bath at 37°C. Marbles were also added to the fluid to provide abrasion with the devices, simulating an intestinal environment. The devices were observed to determine when the cap and vessel portions separated from each other. The resulting average release point for the devices was at 3.84 hours (SD = 0.18 hr).

EXAMPLE 6

Two enteric-coated devices from Example 2, but not containing any active agent formulation, were assembled and placed in artificial gastric fluid (USP XIX, gastric fluid, simulated, TS; modified herein by not including enzymes) for 2 hours, after which they were removed from the gastric fluid and placed in artificial intestinal fluid. The devices were observed in the intestinal fluid to determine when the cap and vessel portions separated. The resulting average release point for the two devices was at 6.33 hours.

EXAMPLE 7

Four devices from Example 3 having a cap membrane thickness of 3-4 mil and containing cardizem pellets as the active agent formulation were placed in artificial intestinal fluid and observed for separation. The devices separated and the cardizem pellets were released to the fluid environment at an average time of about 1.4 hours after placement in the fluid.

In the same manner, three devices from Example 3 having a cap membrane thickness of 8-9 mil and containing cardizem pellets were placed in the artificial intestinal fluid environment. The devices

separated and the cardizem pellets were released at an average time of about 7.1 hours after placement.

EXAMPLE 8

5 Five devices from Example 3 having a cap membrane thickness of
8-9 mil and containing cimetidine granules as the active agent
formulation were placed in artificial intestinal fluid and observed
for separation. The devices separated and the cimetidine granules
were released to the fluid environment at an average time of about
10 6.4 hours after placement in the fluid.

WHAT IS CLAIMED IS:

1. A fluid-imbibing dispensing device for the initial
5 delayed delivery of an active agent to a fluid environment of use,
the device comprising:

(a) a housing having a first wall section and a second wall
section in slidably telescoping arrangement with each other, the
first wall section having an open end adapted to fit within the
10 second wall section and the second wall section comprising in at
least a portion a semipermeable composition, which housing maintains
its integrity in the environment of use;

(b) an internal compartment surrounded and defined by the
first and second wall sections of the housing;

15 (c) at least one active agent formulation in a portion of the
compartment defined by the first wall section;

(d) an expansion means in a portion of the compartment
defined by the second wall section, for separating apart the first
and second wall sections of the housing after exposure to the
20 environment of use; and

(e) a partition layer between the expansion means and the
open end of the first wall section; wherein, there is a negligible
pressure gradient between the environment and the portion of the
compartment defined by the first wall section.

25

2. A fluid-imbibing dispensing device for the initial
delayed delivery of one or two active agents to a fluid environment
of use, the device comprising:

(a) a housing having a first wall section and two second wall
30 sections, the first wall section being in slidably telescoping
arrangement with each of the second wall sections, the first wall
section having an impermeable internal dividing wall and two opposing
open ends adapted to fit within a second wall section and the second
wall sections comprising in at least a portion a semipermeable
35 composition, which housing maintains its integrity in the environment
of use;

(b) two internal compartments surrounded and defined by the first and second wall sections and the internal dividing wall of the housing;

(c) at least one active agent formulation in a portion of each of the internal compartments defined by the first wall section;

(d) an expansion means in a portion of each of the internal compartments defined by the second wall sections, for separating apart the first and second wall sections of the housing after exposure to the environment of use; and

(e) two partition layers, one partition layer being between the expansion means in each of the second wall sections and the open ends of the first wall section; wherein, there is a negligible pressure gradient between the environment and the portion of each of the compartments defined by the first wall section.

15

3. A dispensing device according to claim 1 or 2 wherein the first wall section is comprised of a substantially impermeable composition.

20

4. A dispensing device according to claim 1 or 2 wherein the active agent formulation comprises a liquid, a solid, a semisolid, a thermo-sensitive composition, or a plurality of dosage forms.

25

5. A dispensing device according to claim 2 wherein the active agent formulation in each of the internal compartments comprises the same active agent.

30

6. A dispensing device according to claim 2 wherein the active agent formulation in each of the internal compartments comprises a different active agent one from the other.

35

7. A dispensing device according to claim 2 wherein the composition of the expansion means in each of the internal compartments is different one from the other.

8. A dispensing device according to claim 1 or 2 which further comprises means for providing an initial active agent dose.

9. A method for delaying the initial delivery of an active agent to a fluid environment of use, the method comprising:

(a) placing a dispensing device into the environment of use, the dispensing device comprising:

- 5 (i) a housing having a first wall section and a second wall section in slidably telescoping arrangement with each other, the first wall section having an open end adapted to fit within the second wall section and the second wall section comprising in
10 at least a portion a semipermeable composition, which housing maintains its integrity in the environment of use;
- (ii) an internal compartment surrounded and defined by the first and second wall sections of the housing;
- 15 (iii) at least one active agent formulation in a portion of the compartment defined by the first wall section;
- (iv) an expansion means in a portion of the compartment defined by the second wall section, for separating
20 apart the first and second wall sections of the housing after exposure to the environment of use; and
- (v) a partition layer between the expansion means and the open end of the first wall section;
- 25 (b) allowing fluid to be imbibed through at least a portion of the second wall section of the housing of the dispensing device for causing the expansion means to expand and exert pressure on the slidably connected first and second wall sections, while creating
30 little or no pressure gradient between the environment of use and the portion of the compartment defined by the first wall section; and
- (c) delivering the active agent from the dispensing device by the expansion means increasing in volume, thereby pushing apart and separating the first and second wall sections of the device's housing and exposing the active agent formulation to the environment.

35

10. A method according to claim 9 wherein the first wall section is comprised of a substantially impermeable composition.

11. A method according to claim 9 wherein the active agent formulation comprises a liquid, a solid, a semisolid, a thermo-sensitive composition, or a plurality of dosage forms.

5 12. A method according to claim 9 which further comprises means for providing an initial active agent dose.

10 13. A fluid-imbibing dispensing device for the immediate and continuous delivery of a first active agent together with the delayed, pulsed delivery of a second active agent to a fluid environment of use, the device comprising:

(a) a housing having a first wall section and a second wall section in slidably telescoping arrangement with each other, the first wall section having an open end adapted to fit within the second wall section and the first and the second wall sections each comprising in at least a portion a semipermeable composition, which housing maintains its integrity in the environment of use;

(b) an internal compartment surrounded and defined by the first and second wall sections of the housing;

20 (c) exit means in the first wall section opposite the open end of the first wall section;

(d) a first active agent formulation in a portion of the compartment defined by the first wall section and adjacent the exit means;

25 (e) a first expansion means in a portion of the compartment defined by the first wall section;

(f) a second active agent formulation in a portion of the compartment defined by the first wall section and adjacent the open end of the first wall section;

30 (g) an impermeable barrier layer between the second active agent formulation and the first partition layer;

(h) a second expansion means in a portion of the compartment defined by the second wall section, for separating apart the first and second wall sections of the housing after exposure to the environment of use; and

35 (i) a second partition layer between the expansion means and the open end of the first wall section; wherein, there is a

negligible pressure gradient between the environment of use and the portion of the compartment defined by the first wall section.

5 14. A device according to claim 13 which further comprises a partition layer between the first active agent formulation and the first expansion means.

10 15. A device according to claim 13 wherein the first active agent formulation and the second active agent formulation comprise the same active agent.

16. A device according to claim 13 wherein the first active agent formulation and the second active agent formulation comprise different active agents.

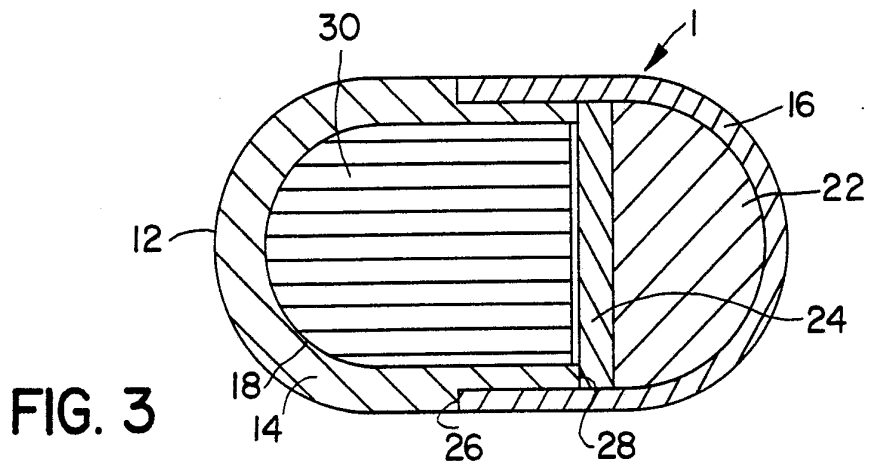
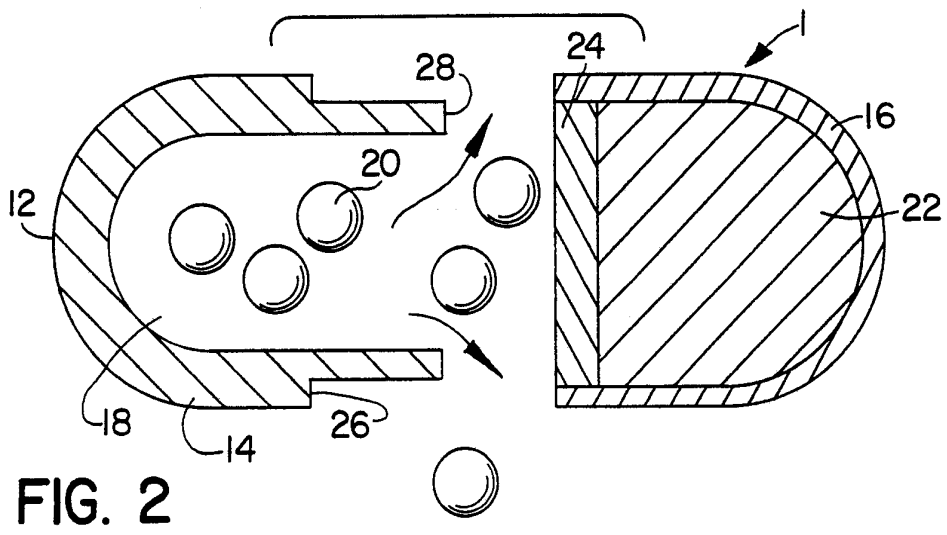
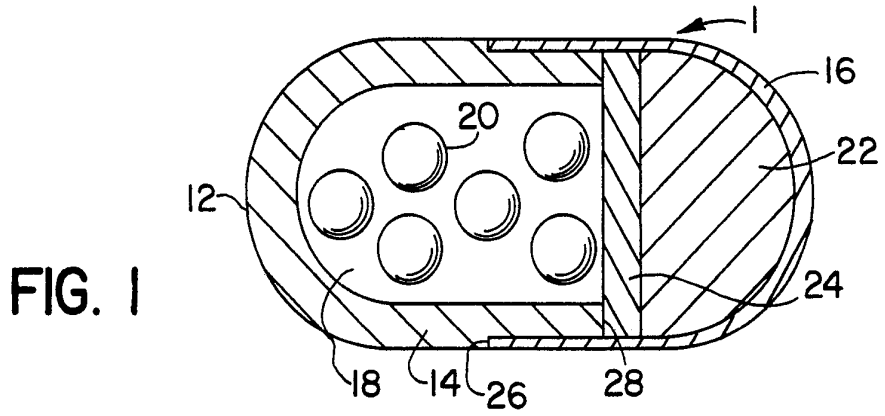

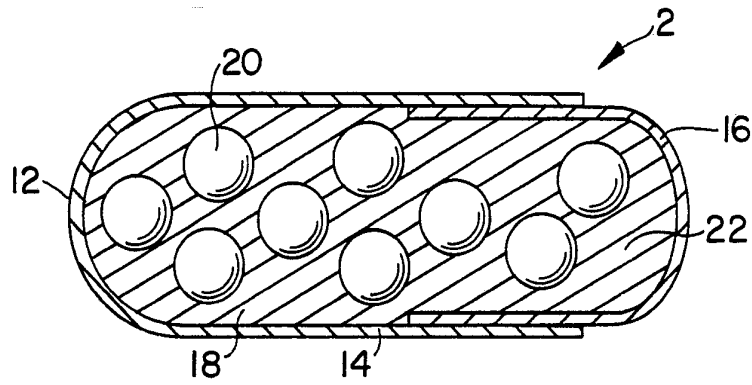

FIG. 4

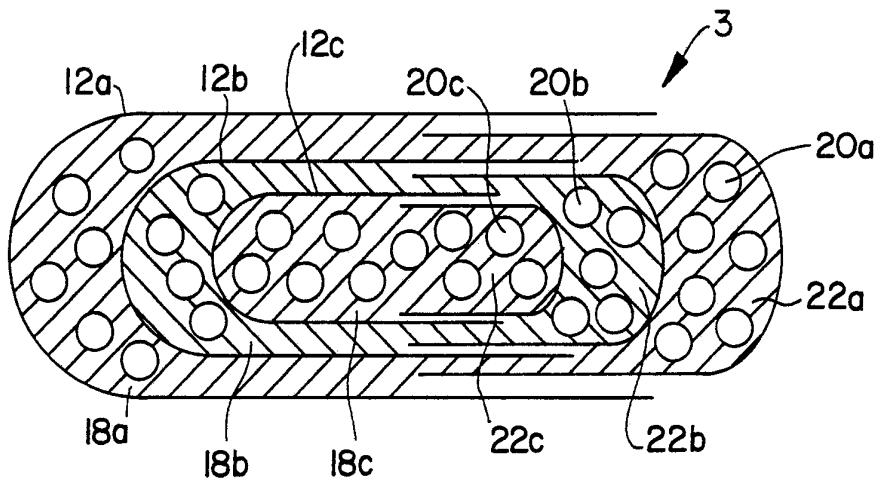

FIG. 5

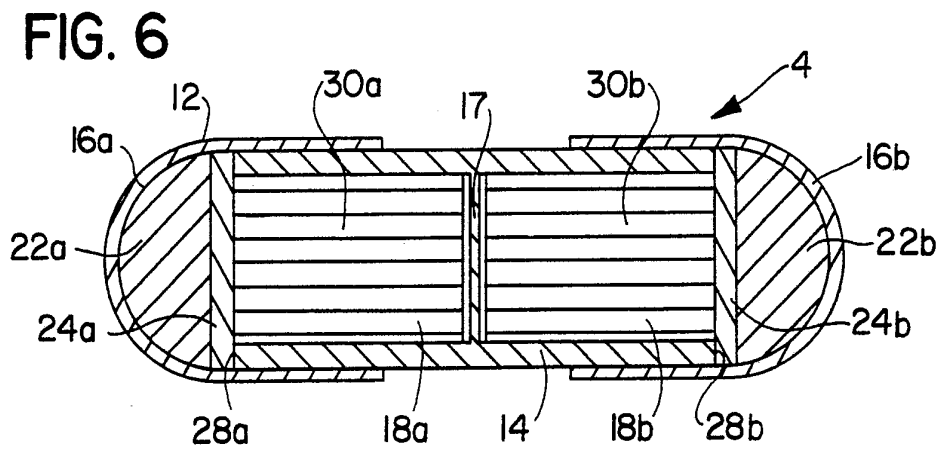

FIG. 6

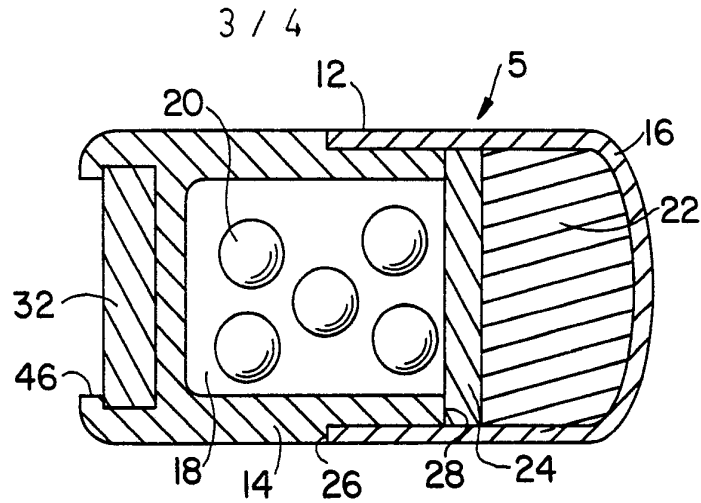

FIG. 7

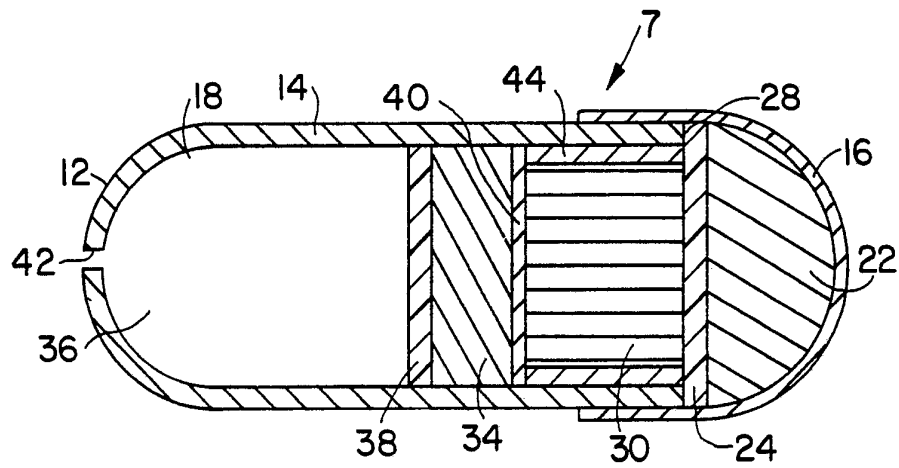

FIG. 9

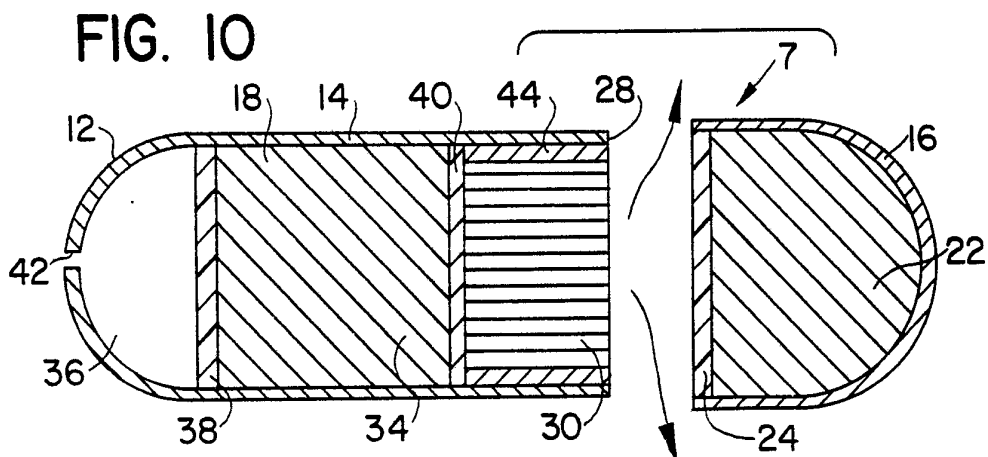

FIG. 8

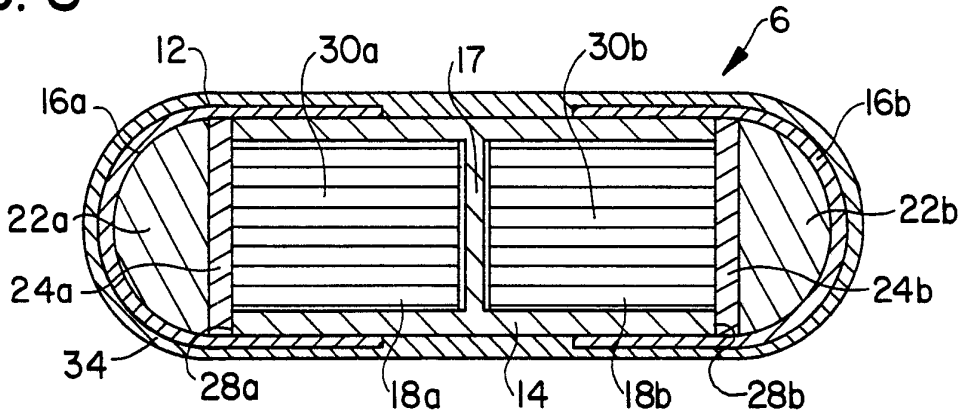

FIG. II

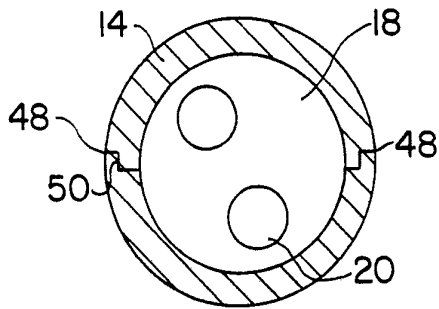
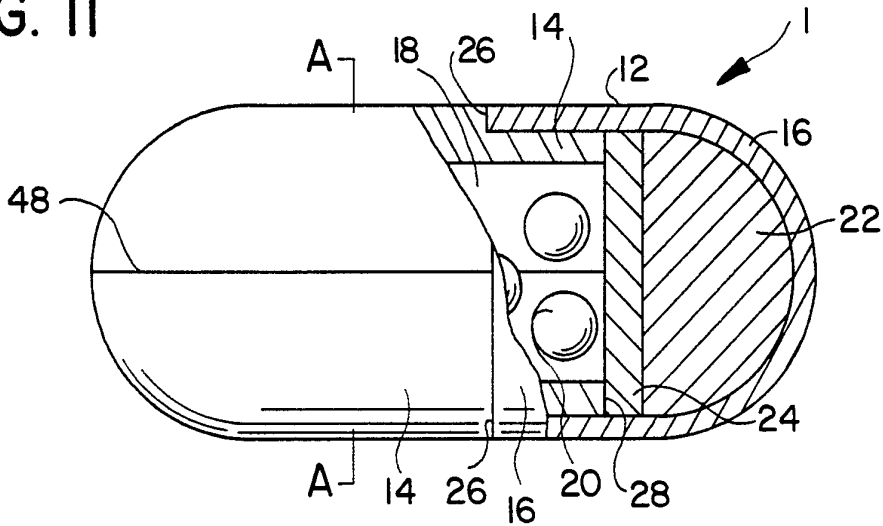

FIG. 12a

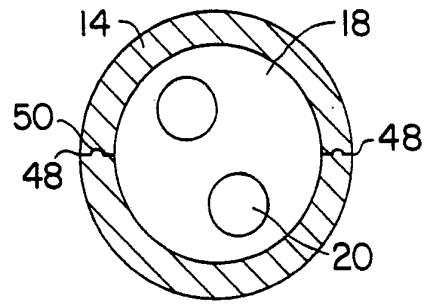
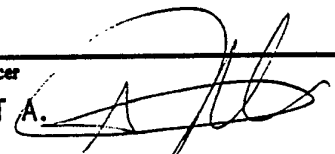

FIG. 12b

INTERNATIONAL SEARCH REPORT

PCT/US 92/00635

International Application No

I. CLASSIFICATION OF SUBJECT MATTER (if several classification symbols apply, indicate all) ⁶		
According to International Patent Classification (IPC) or to both National Classification and IPC Int.Cl. 5 A61K9/00		
II. FIELDS SEARCHED		
Minimum Documentation Searched ⁷		
Classification System	Classification Symbols	
Int.Cl. 5	A61K	
Documentation Searched other than Minimum Documentation to the Extent that such Documents are Included in the Fields Searched ⁸		
III. DOCUMENTS CONSIDERED TO BE RELEVANT⁹		
Category ¹⁰	Citation of Document, ¹¹ with indication, where appropriate, of the relevant passages ¹²	Relevant to Claim No. ¹³
X	EP,A,0 384 642 (NATIONAL RESEARCH DEVELOPMENT CORP.) 29 August 1990 see claims 1,17 see page 2, line 14 - page 2, line 30 see page 2, line 35 - page 2, line 39 see page 2, line 48 - page 2, line 49 see page 3, line 25 - page 3, line 26 see page 5, line 9 - page 5, line 11 --- -/--	1, 3, 4
<p>¹⁰ Special categories of cited documents:</p> <p>"A" document defining the general state of the art which is not considered to be of particular relevance</p> <p>"E" earlier document but published on or after the international filing date</p> <p>"L" document which may throw doubts on priority claim(s) or which is cited to establish the publication date of another citation or other special reason (as specified)</p> <p>"O" document referring to an oral disclosure, use, exhibition or other means</p> <p>"P" document published prior to the international filing date but later than the priority date claimed</p> <p>"T" later document published after the international filing date or priority date and not in conflict with the application but cited to understand the principle or theory underlying the invention</p> <p>"X" document of particular relevance; the claimed invention cannot be considered novel or cannot be considered to involve an inventive step</p> <p>"Y" document of particular relevance; the claimed invention cannot be considered to involve an inventive step when the document is combined with one or more other such documents, such combination being obvious to a person skilled in the art.</p> <p>"Δ" document member of the same patent family</p>		
IV. CERTIFICATION		
Date of the Actual Completion of the International Search	25 MAY 1992	Date of Mailing of this International Search Report
International Searching Authority	EUROPEAN PATENT OFFICE	Signature of Authorized Officer
		VENTURA AMAT A. 

III. DOCUMENTS CONSIDERED TO BE RELEVANT (CONTINUED FROM THE SECOND SHEET)		
Category °	Citation of Document, with indication, where appropriate, of the relevant passages	Relevant to Claim No.
P,X	US,A,5 017 381 (FREDERICK MARUYAMA ET AL.) 21 May 1991 see claims 1-9 see column 3, line 19 - column 3, line 48 see column 3, line 51 - column 3, line 54 see column 4, line 3 - column 4, line 25 see column 4, line 68 - column 5, line 6 see column 5, line 14 - column 5, line 17 see column 5, line 23 - column 5, line 26 see column 5, line 31 - column 5, line 42 ---	1,3,4, 8-12

**ANNEX TO THE INTERNATIONAL SEARCH REPORT
ON INTERNATIONAL PATENT APPLICATION NO.**

US 9200635
SA 57079

This annex lists the patent family members relating to the patent documents cited in the above-mentioned international search report. The members are as contained in the European Patent Office EDP file on
The European Patent Office is in no way liable for these particulars which are merely given for the purpose of information. 25/05/92

Patent document cited in search report	Publication date	Patent family member(s)	Publication date
EP-A-0384642	29-08-90	AU-A- 5096690	05-09-90
		EP-A- 0458835	04-12-91
		WO-A- 9009169	23-08-90
		GB-A- 2230441	24-10-90

US-A-5017381	21-05-91	AU-A- 7160991	27-11-91
		WO-A- 9116884	14-11-91
