

Nov. 13, 1951

G. W. FRANZHEIM

2,574,635

ADJUSTABLE OUTLET BURNER HEAD FOR GAS OR OIL BURNERS

Filed Oct. 1, 1946

Fig. 1.

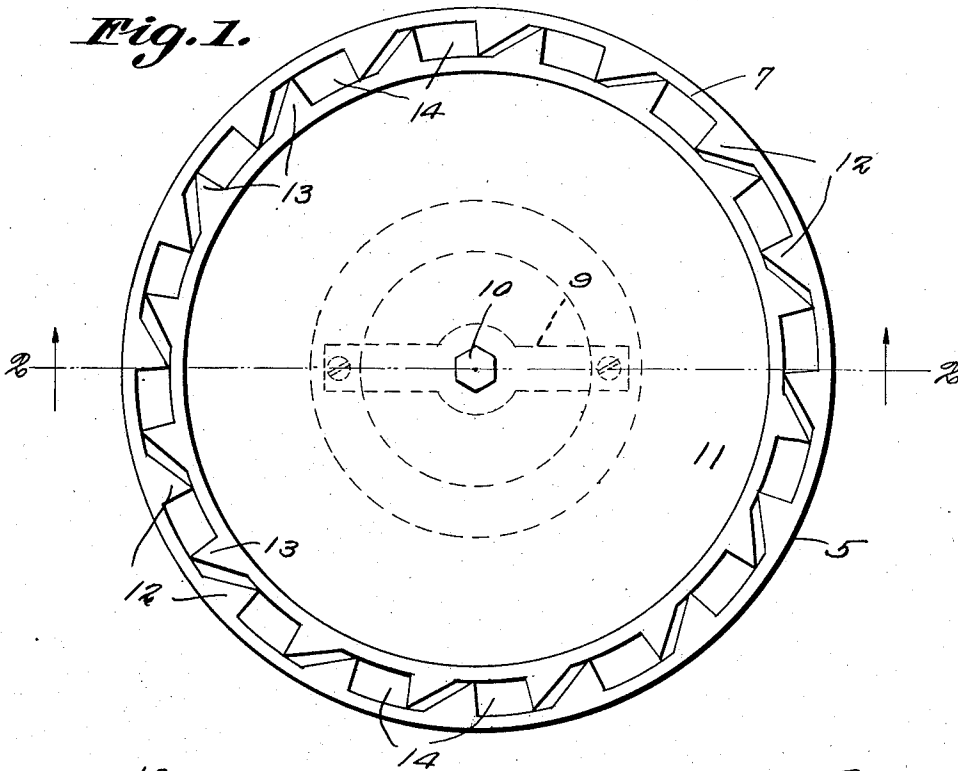
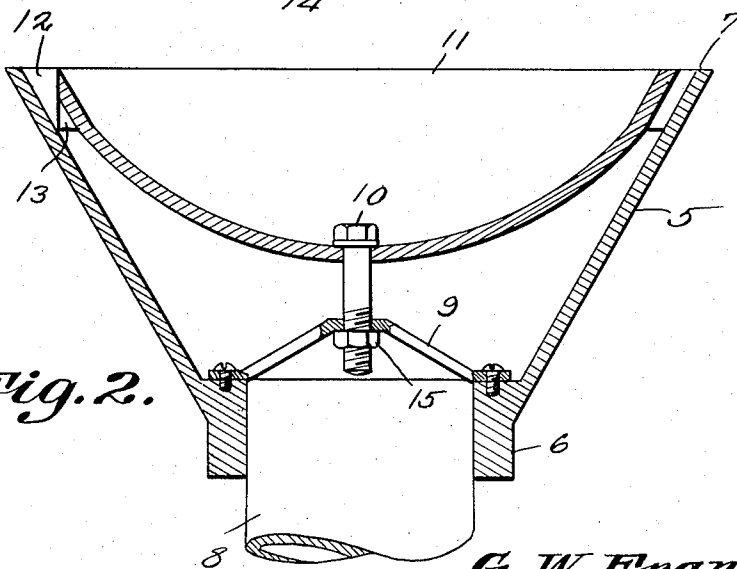

Fig. 2.



Inventor

G. W. Franzheim

By *Albrow & Co.*

Attorneys.

UNITED STATES PATENT OFFICE

2,574,635

ADJUSTABLE OUTLET BURNER HEAD FOR GAS OR OIL BURNERS

George W. Franzheim, Dunkirk, N. Y.

Application October 1, 1946, Serial No. 700,422

3 Claims. (Cl. 158-117)

1

This invention relates to burner heads adapted for gas or oil burning devices, and particularly to those burner heads which are of the adjustable character.

The primary object of the invention is to provide a device of this character wherein it will be possible to produce, in one burner head, effective combustion of any type of gas used, without the necessity of affixing different burner heads to adapt the burner for use in burning different types of gases, such as natural or manufactured gas.

Another important object of the invention is to provide a device wherein a necessary regulation or adjustment to produce effective combustion can be made in a minimum period of time, and without the requirement of special tools, and without the services of specially trained mechanics.

The above objects attain added importance from the fact that utility companies are often required to dispatch specially trained employees for the purpose of installing different burner heads, or making necessary adjustments in those burners already installed, when said companies are required to convert the burner from a burner of the type required for burning manufactured gas, to a burner for burning natural gas, or vice versa.

It is understood that the device, while primarily intended to accommodate various types of gases as hereinbefore stated, is yet intended also to serve as a device wherein proper combustion of other fuels, in particular oil, can be effected.

With the foregoing and other objects in view which will appear as the description proceeds, the invention consists of certain novel details of construction and combinations of parts, hereinafter more fully described and pointed out in the claims, it being understood that changes may be made in the construction and arrangement of parts without departing from the spirit of the invention as claimed.

Referring to the drawing:

Fig. 1 is a top plan view of the invention.

Fig. 2 is a sectional view thereof, taken approximately on line 2-2 of Fig. 1, looking in the direction of the arrows.

Referring to the drawing in detail, the invention embodies a hollow body portion 5 constructed in inverted frusto-conical form, the body portion being flared outwardly and upwardly from its base 6, and being open both at the base 6 and at its upper extremity 7. This body portion 5 is designed at its base to be mounted upon the upper extremity of an intake pipe 8 communicating with a fuel supply not shown.

2

There is affixed to the inner surface of the base 6 a supporting bar 9, which is upwardly inclined at its center and is formed with an opening intermediate its ends for receiving the adjusting bolt 10 which is provided with a nut 15 for securing the deflector 11 in its positions of adjustment. The lower ends of the bar 9 are secured to the base 6 by screws or similar securing means.

The device further embodies a deflector 11 of bowl formation which is mounted within the body portion 5 for rotary adjustment, the upper edge of said deflector being flush with the upper edge or extremity 7 of the body portion 5. The deflector 11 is adapted for rotary adjustment by use of the adjusting bolt 10, which is capable of being turned as necessary to permit free rotary movement of the deflector.

The device further embodies cooperating means between the body portion 5 and the deflector 11 providing openings or ports 14 through which is emitted the flame caused by combustion of the gases consumed within the burning device. This cooperating means includes spaced lugs on the deflector 11 and on the body portion 5, each lug having a straight and an inclined wall.

On the body portion 5 the lugs 12 are disposed along the upper inner circumference thereof, and are extended horizontally inwardly toward the deflector 11. On the deflector the lugs 13 are similarly disposed, except that they extend outwardly toward the body portion 5, the lugs 13 operating between the lugs 12.

It is to be noted that the lugs 12 and 13, when viewed in top plan, are of right-triangular shape, with the points of the lugs 13 contacting the annular upper edge of the body portion 5, and the points of the lugs 12 contacting the annular upper edge of the deflector 11, said upper edges being concentric and spaced apart. The lugs 12 and 13 are so arranged, in this connection, that one side of each lug, whether it be a lug 12 or lug 13, extends substantially radially of said annular upper edges, while the other side surface of each lug is disposed chordally to said annular edges. The substantially radial side wall of each lug 12 is disposed opposite the corresponding side wall of an adjacent lug 13, while the chordal side wall of each lug 12 is opposite the chordal side wall of an adjacent lug 13. As a result, when the chordal walls of adjacent lugs 12 and 13 are positioned in contact, the ports 14 will be of approximately rectangular shape and will be of minimum number, 16 in the present instance. When the radial side walls are in contact, the ports will still be of minimum number, but will now be formed as substantially diamond shaped

3

parallelograms. When each lug 12 is spaced apart from the lugs 13 on either side thereof, the number of ports will be doubled, with rectangular ports alternating with ports of oblique parallelogram shape. The comparative sizes of these alternating ports can be varied, of course, by selected location of lugs 12 relative to lugs 13.

The arrangement is one specifically devised to provide a wide variety of adjustments for shaping of the flame at point of issuance thereof through the ports, whether natural gas, manufactured gas, or mixed gas be used.

As hereinbefore stated, the deflector 11 is adapted to rotate within the body portion 5 to adjust the lugs of the body portion 5 and deflector 11, with respect to each other. The opposing lugs 12 and 13 are adapted to be positioned in prescribed relation to each other and when positioned directly against each other, they form a minimum prescribed number of ports 14. When they are positioned apart from each other, the number of ports 14 is doubled, the size of each port being dependent upon the distance the opposing lugs 12 and 13 are moved apart from each other.

The forming of the minimum number of ports 14 through positioning of opposing lugs 12 and 13 one against the other, provides proper openings for producing effective combustion of natural gas. The doubling of the number of said ports 14 provides openings which are proper for producing effective combustion of mixed or manufactured gas, the size of the openings most desirable for combustion of the particular type of gas being capable of regulation in the manner hereinbefore described.

What is claimed is:

1. A burner head including a body portion and deflector connected for relative rotary adjustment, the body portion having spaced inlet and outlet openings and the deflector being positioned across the outlet opening with its peripheral edge spaced from the outlet opening edge to define an annular space therebetween, an annular series of lugs on the body portion, and an annular series of lugs on the deflector, the lugs of both series each being of substantially right-triangular configuration when viewed in top plan, each lug having one side wall disposed substantially radially of said annular space and another side wall disposed chordally of said annular space, the substantially radial side walls of the lugs of the deflectors being disposed to contact the corresponding side walls of the body portion lugs, and the chordal side walls of the deflector lugs being disposed to contact the chordal side walls of the body portion lugs, the lugs of both series extending across the space to divide the space into an annular series of outlet ports, the lugs of one series adapted on selected adjustments of the body portion and deflector to engage the lugs of the other series to reduce the number of ports while increasing the area of each port remaining, and to increase the number of ports while reducing the area of each port, said lugs of both series, peripheral deflector edge, and outlet opening edge being all disposed in a horizontal plane common with the plane of the uppermost end of the burner head.

2. A burner head including a body portion and deflector connected for relative rotary adjustment, the body portion having inlet and outlet openings and the deflector being positioned across the outlet opening, there being an annular open space left between the peripheral edge of the deflector and the edge of the outlet opening, lugs

4

on the body portion and deflector respectively, extending across and dividing said space into a plurality of outlet ports, the lugs of both series each being of substantially right-triangular configuration when viewed in top plan, each lug having one side wall disposed substantially radially of said annular space and another side wall disposed chordally of said annular space, the substantially radial side walls of the lugs of the deflectors being disposed to contact the corresponding side walls of the body portion lugs, and the chordal side walls of the deflector lugs being disposed to contact the chordal side walls of the body portion lugs, the body portion lugs alternating with the deflector lugs whereby on rotary adjustment in one direction, adjacent lugs will engage and reduce the number of ports while increasing the individual areas of the ports, and on adjustment in the other direction, adjacent lugs will be spaced apart to increase the number of ports while reducing the individual areas of the ports, said peripheral edge of the deflector, edge of the body portion outlet opening, and lugs of the body portion and deflector respectively, being all disposed in a horizontal plane common with the plane of the uppermost end of the burner head.

3. A burner head including a stationary body portion having inlet and outlet openings, a deflector mounted in the body portion and covering the central area of the outlet opening, thus to define an annular space at the margin of the outlet opening and surrounding the deflector, means connecting the deflector to the body portion for rotary adjustment of the deflector relative to the body portion, a series of lugs rigid with the deflector, and a series of lugs rigid with the body portion, the lugs of both series each being of substantially right-triangular configuration when viewed in top plan, each lug having one side wall disposed substantially radially of said annular space and another side wall disposed chordally of said annular space, the substantially radial side walls of the lugs of the deflectors being disposed to contact the corresponding side walls of the body portion lugs, and the chordal side walls of the deflector lugs being disposed to contact the chordal side walls of the body portion lugs, the deflector lugs alternating with the body portion lugs and the lugs of both series extending across and dividing said space into a plurality of outlet ports, said adjustable connection between the deflector and body portion adapted to selectively position the lugs to increase the number of outlet ports while reducing their individual area, and to reduce the number of ports while increasing their individual area, said annular space and both series of lugs being located entirely in a horizontal plane common with the plane of the uppermost end of the burner head.

GEORGE W. FRANZHEIM.

REFERENCES CITED

The following references are of record in the file of this patent:

UNITED STATES PATENTS

Number	Name	Date
461,886	Mains	Oct. 27, 1891
1,663,339	Geurink et al.	Mar. 20, 1928

FOREIGN PATENTS

Number	Country	Date
162,641	Great Britain	1921
289,617	Great Britain	May 3, 1928
496,819	France	Mar. 11, 1919