

[54] **MULTI-POSITION BRUSH NOZZLE FOR VACUUM CLEANER**

2,348,861 5/1944 Smellie ..... 15/373 X  
 2,948,014 8/1960 Allen ..... 15/371

[75] Inventor: **Donald P. Grover**, Naperville, Ill.

*Primary Examiner*—Harvey C. Hornsby

[73] Assignee: **Sunbeam Corporation**, Chicago, Ill.

*Assistant Examiner*—C. K. Moore

[22] Filed: **June 19, 1972**

*Attorney, Agent, or Firm*—George R. Clark; Neil M. Rose; John S. Pacocha

[21] Appl. No.: **263,997**

[52] **U.S. Cl.**..... 15/339, 15/371, 15/373

[51] **Int. Cl.**..... A47I 9/00, A47I 5/34

[58] **Field of Search** ..... 15/368, 371, 373, 398,  
 15/365, 339

[57] **ABSTRACT**

A vacuum cleaner nozzle including a brush which is spring biased in the housing of the nozzle and which is adjustable to three separate positions for cleaning high pile carpets, bare floors and low pile carpets is disclosed. An adjustment lever adjusts the position of a sliding cam member longitudinally along the housing of the nozzle in a manner which selects one of the three operation positions of the brush.

[56] **References Cited**

**UNITED STATES PATENTS**

1,753,799	4/1930	Martinet .....	15/371
2,034,196	3/1936	Martinet .....	15/371
2,205,877	6/1940	Dunbar .....	14/368

**3 Claims, 9 Drawing Figures**

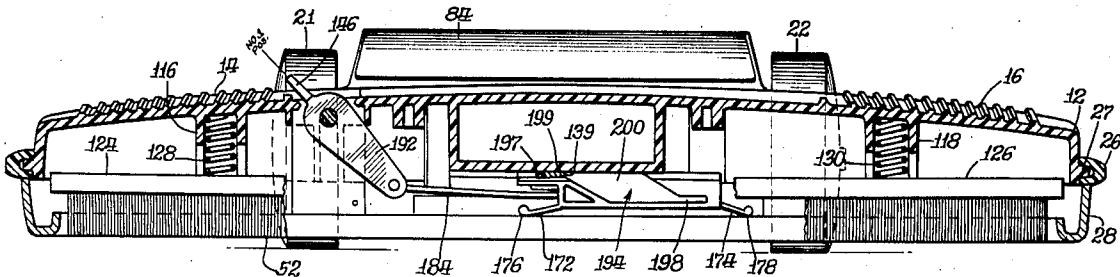

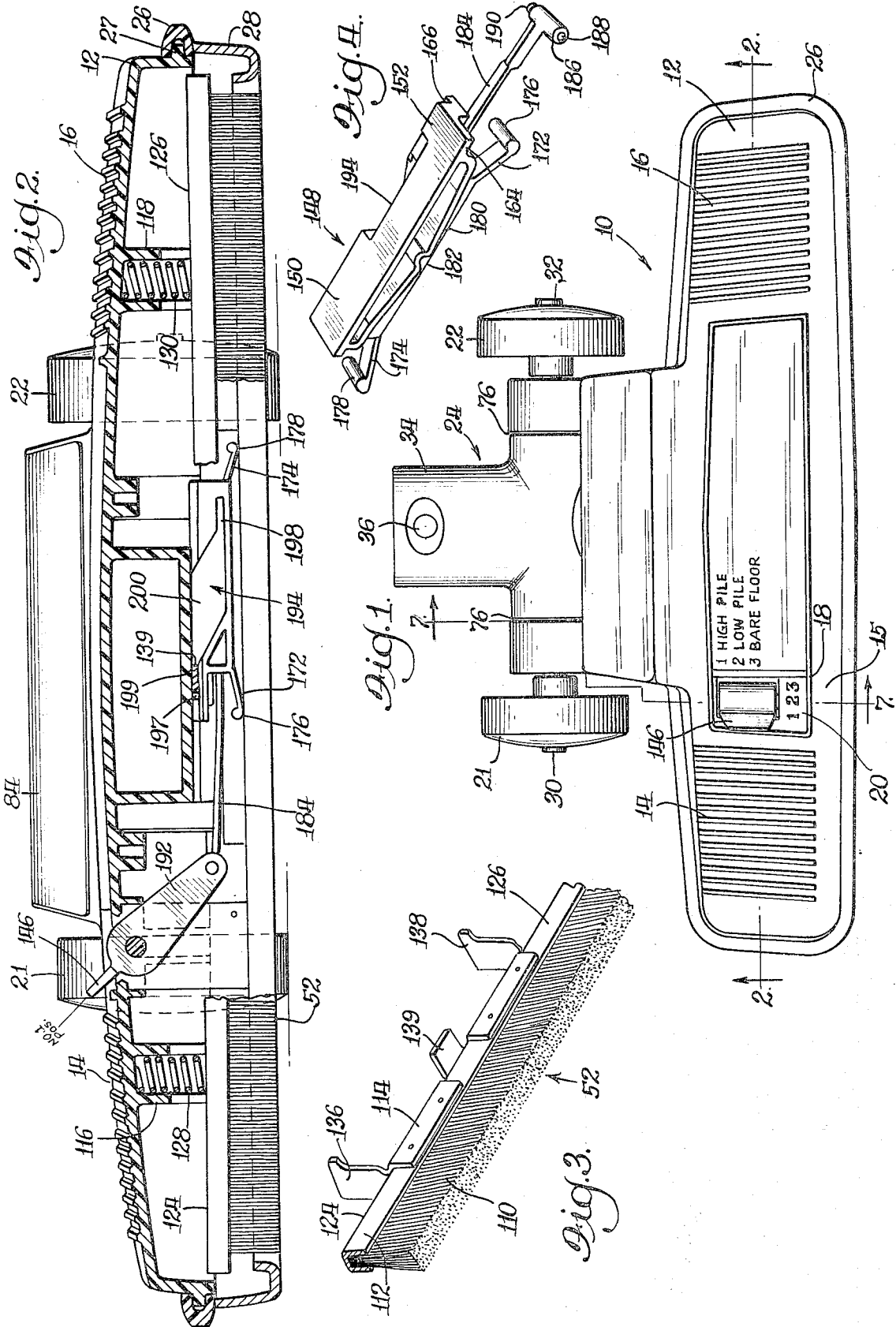



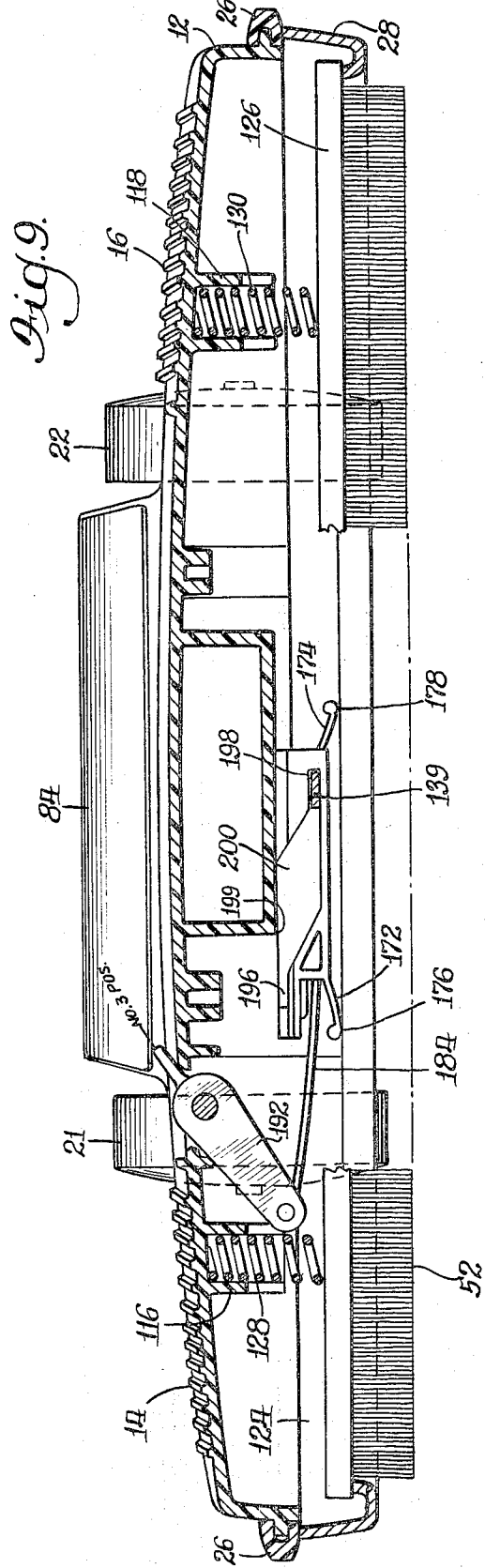
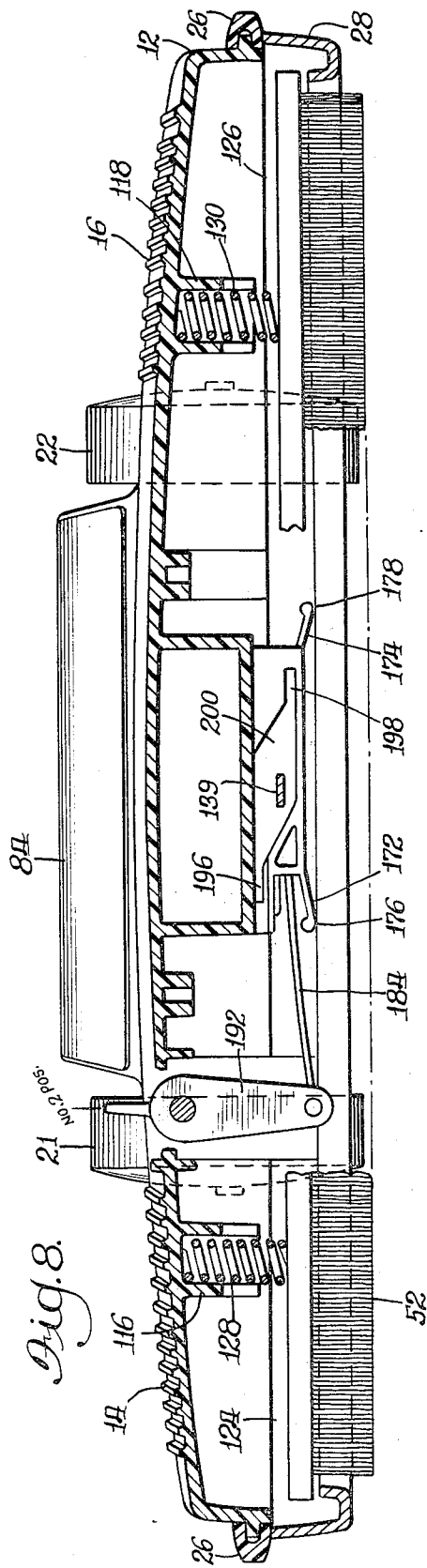

## MULTI-POSITION BRUSH NOZZLE FOR VACUUM CLEANER

### BACKGROUND OF THE INVENTION

The present invention relates to a structurally and functionally improved vacuum cleaner nozzle and brush assembly which is suitable for use with a vacuum cleaner. To satisfy customer demand, a modern vacuum cleaner nozzle with a brush must be useable on both high and low pile carpets and on bare floors, and the adjustment of the brush for each of these cleaning chores must be accomplished in a reliable, but economical manner. In addition, it is highly desirable to arrange the adjustment mechanism so that the operator can easily see the position that the cleaning brush is in at all times.

It is an object of the present invention to furnish an improved vacuum cleaner nozzle and brush assembly which may be used for cleaning both high and low pile carpet and also for cleaning bare floors without the marring thereof.

It is another object of the present invention to provide a vacuum cleaning nozzle and brush assembly wherein the brush may be adjusted to a plurality of separate and distinct positions, and a visual indication of each brush position is provided to the operator.

It is a further object of the present invention to provide an improved vacuum cleaner nozzle and brush assembly wherein the brush may be adjusted for the cleaning of various types of surfaces by movement of an adjusting knob which has an indicating segment that projects through the upper housing of the nozzle.

Other objects and advantages of the invention will be apparent from the following specification and drawings wherein:

### DESCRIPTION OF THE DRAWINGS

FIG. 1 is a top view of the vacuum cleaning nozzle assembly of the present invention.

FIG. 2 is a cross sectional view of the nozzle assembly taken along the line 2—2 of FIG. 1, which shows the indicating arm in the number 1, or high pile position;

FIG. 3 is a perspective view of the brush assembly;

FIG. 4 is a perspective view of the adjusting cam;

FIG. 5 is a view showing the inside of the lower nozzle shoe section of the housing;

FIG. 6 is a view showing the inside of the plastic upper section of the housing;

FIG. 7 is a cross sectional view of the nozzle assembly taken along the lines 7—7 of FIG. 1;

FIG. 8 is a cross sectional view of the nozzle assembly taken along the lines 2—2 of FIG. 1, which shows the indicating segment in the number 2, or low pile carpet, position and

FIG. 9 is a cross sectional view of the nozzle assembly taken along the line 2—2 of FIG. 1, which shows the indicating segment in the number 3, or bare floor, position.

### TECHNICAL DESCRIPTION OF THE INVENTION

In FIG. 1 the reference numeral 10 refers generally to the nozzle assembly of the present invention. The housing of nozzle assembly 10 is formed by the plastic upper section 12 and the lower metallic nozzle shoe

section 28. The upper housing section 12 of the nozzle housing is decorated with the ribs 14 and 16 and the hot stamped chrome border 18 to give the assembly an appealing appearance. The chrome numerals 20 serve to indicate the operation position of the brush assembly 52. The plastic that is used for the upper housing section 12 must be fairly strong and rigid and, therefore, a high impact polystyrene plastic is preferred. The supporting wheels 21 and 22 and the nozzle pivot assembly 24 are also preferably constructed of plastic. A bumper 26 made of rubber, or other resilient material, surrounds the outer edge 27 of the nozzle housing 12 to prevent marring of a piece of furniture if the nozzle is accidentally run into it.

The metallic nozzle shoe 28, which is preferably formed of a lightweight die cast alloy or of a light metal such as aluminum, is secured to the underside of the upper section 12 of the housing. The metallic nozzle shoe 28 supports the wheel axles 30 and 32, and it also lends rigidity and strength to the nozzle assembly. The wheels 21 and 22 may be held onto their respective axles 30 and 32 by means of locking caps, or other suitable conventional devices.

The aluminum die cast nozzle shoe 28 is shown in greater detail in FIG. 5. The axles 30 and 32 for the wheels 21 and 22 extend into bearings that are contained in the bearing hubs 38 and 40 which are formed integrally with the nozzle shoe 28. The holes 42, 44, 46 and 48 are provided to receive the mounting screws which secure the nozzle shoe 28 to the upper section 12 of the housing. The holes 46 and 48 are provided with the recesses 47 and 49, respectively, so that the heads of the associated mounting screws do not project outwardly beyond the bottom of the nozzle shoe 28, thereby preventing marring or snagging of the surface being cleaned. The screws which are associated with the screw holes 42 and 44 are at a level such that their heads are farther removed from the surface of the floor than are the heads of the screws for holes 46 and 48 when the nozzle is assembled, and, therefore, the holes 42 and 44 do not have to be provided with a screw head recess.

The bristles 110 of the brush assembly 52 pass through the open channel 50 which is of a size such that the downward extension of the somewhat larger brush assembly 52 is limited. The surfaces 53 and 55 in the front portion of the nozzle shoe 28 form an upwardly sloping channel which leads to the opening 54 which is in vacuum communication with the connecting tube 34. The required suction for operating the nozzle of the present invention is provided through the connecting tube 34 of the pivot assembly 24. The tube 34 is provided with an aperture 36 which receives a locking pin of an extension tube or cable which is coupled to the associated vacuum cleaner (not shown). Thus, the dirt that is picked up enters the entrance opening 54 and passes through the nozzle assembly and the tube 34 to the vacuum cleaner.

The underside of the plastic upper section 12 of the nozzle housing 10 is shown in FIG. 6. The upper section 12 is of a generally rectangular shape, and it has a pair of fenders 60 and 62 which are formed on the rear portions of the upper section 12. The fenders 60 and 62, along with the flanges 56 and 58 of the nozzle shoe 28, which support the axles 30 and 32, form enclosures over the bearing hubs 38 and 40. The sleeves 64 and 66, which are formed integrally with the inner walls 68

and 70 of the fenders 60 and 62, respectively, receive an axle 72 (shown in FIG. 7) that allows for pivotal motion of the nozzle pivot assembly 24 with respect to the nozzle housing 10. The cylindrical face 82 of the pivot assembly 24 preferably rides against compressible sealing material 84 which is in engagement with the curved surface 85 of the upper section 12. In this manner sealing and smooth pivotal action will be provided for the nozzle pivot assembly 24.

The screw posts 88 and 90 in the upper portion 12 of the nozzle assembly 10 receive the screws that are associated with the screw holes 46 and 48, respectively, of the nozzle shoe 28 when the housing is assembled. The screw posts 92 and 94 in the upper portion 12 receive the screws which are associated with the holes 42 and 44, respectively, of the nozzle shoe 28. The nozzle pivot assembly 24 has a pair of projections 74 which extend outwardly past the surfaces 78 and 80 of the fenders 60 and 62 (shown in FIG. 6), respectively. A spring (not shown) is coupled between a screw which is screwed into one of the screw posts 95 and a screw which is screwed into one of the projections 74 to bias the nozzle housing downwardly when the nozzle pivot assembly 24 is held in a generally upright position during operation. In this manner the action of the operator in using the vacuum cleaner in an upright position serves to hold the lightweight housing of the nozzle assembly 10 in contact with the surface that is being cleaned.

A generally rectangular suction channel 96, which forms part of the suction path of the nozzle, is formed over the surface 100 of the housing section 12. A fence-like enclosure 102 surrounds the inlet opening 98 to the suction channel 96. The back wall 104 of the fence-like enclosure 102 extends downwardly farther toward the surface being cleaned than do the other walls of the enclosure 102. The metallic perimeter 106 of the nozzle shoe 28 surrounds the entrance opening 54 and the forward surface of the wall 104 engages the rear surface of the rear wall 108 of the perimeter 106. The fence-like enclosure 102, the walls 104 and 108, and the perimeter 106 thus forms a seal around the entrance opening 54.

The brush assembly 52, shown in FIG. 3 is preferably formed of bristles 110 which are relatively stiff and are clamped in place in a generally U-shaped lightweight metal frame 112. The brush guide member 114 may be secured to the metal frame 112 by prick punching, or by other suitable methods. The hollow posts 116 and 118 of the upper section 12 are provided with the slots 120 and 122 to receive the end segments 124 and 126 of the frame 112. The coiled springs 128 and 130 which are inserted into the hollow posts 116 and 118 bear against the end segments 124 and 126 to provide a downward bias for the brush assembly 52.

The surface 137 of the suction channel 96 is provided with a pair of guide walls 132 and 134 which extend downwardly from the surface 100 of the upper section 12. When the nozzle and brush assembly of the present invention is assembled the guide wings 136 and 138 of the brush guide member 114 are positioned between the guide walls 132 and 134 and the back wall 104. In this way the brush assembly 52 is guided in its upward and downward movement in a manner such that the frame 112 of the brush guide assembly 52 remains substantially parallel to the surface 137. The ribs 140 and 142 which are formed on the suction channel 96 pro-

vide low friction bearing surfaces for the guide wings 136 and 138 as the brush assembly 52 moves up and down in the nozzle and brush assembly 10.

The brush control knob 144, which is preferably formed of a plastic such as acetal, is used to control the operating position of the brush assembly 52. The knob 144 has an outwardly projecting indicating segment 146 which may be moved into alignment with any of the chrome numbers 1, 2 or 3 on the upper surface 15 of the housing assembly 10. When the segment 146 is moved to one of the positions 1, 2 or 3, the position of the slideable cam 148, shown in FIG. 4, in the housing is established. This in turn controls the operation of the brush assembly 52 and the position of the brush 110. When the knob 144 is moved so that the indicating segment 146 is in alignment with the number 1, the brush 110 is retracted into the housing, and it is locked in position so that the brush assembly 52 does not cause excessive drag on high pile carpet. When the knob 144 is moved so that the indicating segment 146 is in alignment with the number 2, the vacuum nozzle may be used on low or short pile carpets. At this position, the brush assembly 52 may undergo upward and downward or "floating" motion in the nozzle housing. When the knob 144 is moved so that the indicating segment 46 is in alignment with the number 3 the brush 110 extends downwardly from the housing, but it is locked in position and the nozzle may then be used to clean bare floors and hard surfaces.

A perspective view of the cam 148 is shown in FIG. 4. The cam 148 has an elongated body section 150 which has a generally flat upper surface 152 which slides on the ribs 154 which are formed on the surface 137 of the suction channel 96. Extending from the surface 137 are four guide walls 156, 158, 160 and 162. The rear edge 164 of the cam member slides against the rear guide walls 158 and 162 while the notch 166 fits over the forward guide walls 156 and 160. The cam 148 is received in the channel formed by the guide walls 156, 158, 160 and 162 and it slides back and forth in this channel with the ribs 154 providing a low friction contact with the flat surface 152.

The knob 144 also has a pair of cylindrical sections 204 and 206 which project from opposite sides of the knob. The cylindrical section 204 is somewhat shorter than the cylindrical section 206 and is received in a plastic cradle 220 which is formed in the upper section 12. Near the plastic cradle 220 are a number of vertical support ribs 223 and a wall 221 which faces toward the rear of the nozzle. A stiff retainer 214 made of fiberboard, or similar material, has a semi-circular notch 216 in it which fits over the cylindrical section 204. One end of the retainer 214 is inserted between the wall 221 and the vertical support ribs 223 and the other end is wedged against the metal nozzle shoe 28 so as to lock the cylindrical section 204 into place in the nozzle assembly.

The longer cylindrical section 206, which has an increased diameter segment 210 intermediate its ends, is supported at one point by a cradle 212 and is supported at a point closer to the knob 144 by the cradle 218. Both of the cradles 212 and 218 are integrally formed in the plastic upper section 12. Near the cradle 212 is a wall 213. A stiff retainer 226, which has a semi-circular notch 230 in it which fits over the cylindrical section 206, is inserted into the wall 213 and the other end of the retainer is wedged against the nozzle shoe 28

in the vicinity of the channel that formed by the surfaces 53 and 55. The increased diameter segment 210 rides in a semi-circular bearing formation 224 which is formed in the upper section 12.

The bottom surface 180 of the cam 148 slopes downwardly from both sides to the middle, where a semi-circular indentation 182 is provided, thus forming a spring detent. Three projections 41, 43 and 45 of generally semi-circular shape are formed on the middle section 46 of the nozzle shoe 28. The indentation 182 and the projections 41, 43 and 45 thereby provide a resilient detent means for each of the three positions of the brush assembly. The movement of the cam 148 is controlled by the knob 144 and the connecting arm 184. A cylinder 186 is formed on the end of the connecting arm 184 which has reduced diameter cylindrical portions 188 and 190 on its ends. The cylindrical portions 188 and 190 are received between the yolk 192 which is formed integrally with the knob arm 144. When the adjustable brush is in each one of its three positions one of the projections 41, 43 or 45 will be in engagement with the indentation 182 on the cam 148. As shown in FIG. 2, when the adjustment is made for the number 1, or high pile position the indentation 182 will be in engagement with the right most projection 45. When the brush has been adjusted to its number 2, or low pile position, the middle projection 43 will be in engagement with the indentation 182. When the brush has been adjusted to its number 3, or bare floor position, the left most projection 41 will be in engagement with the indentation 182.

A control projection 139 extends from the brush assembly 52 and projects into a chamber 194 that is formed in the cam 148. The chamber 194 has an upper restricted area or slot 196 that is formed partly by the lower surface 199 of the upper section 12, a lower restricted area or slot 198 and an open cavity 200. The width of the projection 139 is just slightly smaller than the width of the slots 196 and 198. Thus, when the knob 144 is moved so that the indicating arm 146 is in alignment with the number 1, (high pile position), as shown in FIG. 2, the cam member 148 is forced to the right so that the projection 139 is in the slot 196. The indentation 182 and the projection 45 on the nozzle shoe 28 will then be in engagement and they will hold the cam 148 in this position until the knob 144 is again moved. With the cam member 148 in this position the brush assembly 52 will be withdrawn into the nozzle assembly 10 so that the nozzle may be used on a high pile carpet without excessive drag of the brush on the carpet pile. The cylindrical projections 176 and 178 at the ends of the flexible arms 172 and 174, respectively, of the cam 148 bear against the under surface of the nozzle shoe near the edge 51. The resilient arms 172 and 174 of the cam 148 act as spring members which take up looseness in the fit of the cam 148 in the housing due to tolerance variations, and they also help to stabilize the motion of the cam 148 as it moves back and forth in the housing.

When the knob 144 is moved so that the indicating segment 146 is in alignment with the number 2, (low pile position) the cam moves towards the center of the nozzle and the projection 43 of the nozzle shoe 28 engages the notch 182 and the connecting arm 184 is stressed downwardly, as shown in FIG. 8. In this position the projection 139 is positioned in the cavity 200 and, therefore, the brush assembly 52 is allowed to

freely move up and down against the bias of the bias springs 128 and 130. This free-floating action is preferred for use with low pile carpeting to insure maximum cleaning.

When the knob 144 is moved so that the indicating arm 196 is in alignment with the number 3, (bare floor position) the connecting arm 184 is stressed upwardly and the cam 148 is moved to its left-most position where the projection 41 engages in indentation 182. In this position the projection 139 of the brush assembly 52 is in engagement with the edges of the slot 198 and the bristles 110 extend down below the bottom of the nozzle shoe 28 and are locked in position. This brush position is preferred for operation with bare floors and for other applications where a fixed extending brush provides more effective cleaning.

Although a particular embodiment of the present invention has been described, it is not intended that the present invention be limited to the particular embodiment illustrated herein since variations and modifications thereof will be apparent within the scope of the present invention to those skilled in the art.

What is claimed as new and desired to be secured by Letters Patent of the United States is:

1. A nozzle assembly for use with a vacuum cleaner comprising an elongated upper housing member having an upper surface with an aperture therein, indicia on said upper surface which are visible to the operator of said nozzle assembly, a suction channel having an inlet opening and an outlet opening for connection to a source of suction to draw air into said inlet opening and through said suction channel, an elongated guide channel formed by said suction channel and a plurality of downwardly depending parallel guide walls which are positioned rearwardly of said inlet opening and which run in the direction parallel to the long dimension of said elongated upper housing member, at least one brush assembly guide wall positioned forwardly of said parallel guide walls, an elongated lower housing member having wheel support means, elongated brush assembly opening in said lower housing member located rearwardly of said inlet suction opening, an elongated brush assembly comprising a frame member and a plurality of downwardly extending bristles, said frame member having a control projection and a pair of guide wings which cooperate with said brush assembly guide wall and said parallel guide walls to guide said brush assembly when said brush assembly is undergoing upward and downward motion, means for securing said upper and lower housing members together, means for resiliently biasing said brush frame member downwardly, means for limiting the downward extension of said brush assembly, a cam, cam control means having a control arm coupled to said cam and indicating means coupled to said control arm which has an indicating member that extends through said aperture in said upper surface of said upper housing member for providing an indication of the position of said cam in cooperation with said indicia, said cam control means being constructed such that said cam slides between said parallel cam guide walls in a direction parallel to the long dimension of said elongated upper housing member to at least three distinct positions, said cam comprising a first restricted area at a high level with respect to the surface being cleaned, a second restricted area at a low level with respect to the surface being cleaned and an open area, said control projection of said brush assem-

7

bly being located in said high level restricted area when said cam is in said first position, said control projection being located in said open area when said cam is in said second position and said control projection being located in said low level restricted area when said cam is in said third position.

2. A nozzle assembly as set forth in claim 1 comprising detent means provided by said housing and by said

8

cam at each of said three positions.

3. A nozzle assembly as set forth in claim 2 wherein said detent means is formed by three projections on said elongated housing which are spaced along the long dimension of said housing and an indentation in said cam.

\* \* \* \* \*

10

15

20

25

30

35

40

45

50

55

60

65