

(19)
(12)

(KR)
(Y1)

(51) 。 Int. Cl.7
A61B 17/70

(45)
(11)
(24)

2004 11 10
20-0367241
2004 10 30

(21) 20-2004-0024609 ()
(22) 2004 08 27
(62) 10-2004-0067898
: 2004 08 27

2004 08 27

(73) 3 301-101

(72) 3 301-101

(74)

:

(54)

가 , 가 ,

4

1

2

3

4

5

6

7

8

9

* *

20: 21:

24: 25: 251:

253: 26:

27: 29: 30:

40: 50:

가

가

가

1 2 2001-0009766 (10) (10) 1

2 (11) (10) , ()가 (12) (11) (1

1) (14) (12) (14) (12) (12)

(15)

(10) , 3 (14) 가 (14)

(15) (10) (61) (14) (15) (10) (14)

(14) (15)

(15) (12) 가 (15)

16) , (12) (12) (16) (12) (12) (14) , (14) ()
(14) 가 . (14) .

- 1 , 가 , 가
- 2 , 1 ,
가 .
- 3 , 1 ,
- 4 , 1 3
, 가 ,
- 5 , 4 ,
- 6 , 5 ,
- 7 , 6 ,

4 4 5 , (20) (21) 5 (21) (20)
(24)

(21) 가 U (20)가 (22) (21) ()가 (23)
, 가 U (21) 가 U , U

(22) U (22) (21) 가 (21) 가 U (22) U , U
(21) U 가 (22) 가 U (22) U (22)

가 (25)가 .

) (23) U (22) (21) 가 (23) ()가 . . (23) ()

(25) (24) 가 (21) (26), (21) (24) (24) (25), (27) 가 . (24) (29) (29)

(25) (25) (21) (24)가 가 (24) (25) (26) 가 (25)

(251) , 6 (25) (251) (251) 가 . (25) (251)

(213) (251) U (22) (24) 가 , (251)가 (24) , (253)가 (24) (24) , (251) (24) (253) (needle)

(253) (253) (26) (251) (251) 가 . (253) (253) (26) (24) (24) (20) (253)

(26) (26) (24) (20) (25) (25) , (26) (27) (26) (20)

26) (25) , (27) (27) (29) (2) (27) (27) (27)가 (24) D1 (24) D (27) (27) (273) (273) 가 (24) (a) (20) 가 , (27) (20)가 (27)가 (27) (273) (27) (273) (20) (29) D2 가 (21) (27) (27) (29) 가 (27) (251) (27)

8 9

(20) 가 (20) (27)가 (tapping) (27)
(25)가 (25)

8 (20) (251) (50) (25) (26)
(25) (26)

9 (40) (21) (20) (23) (30) U (22)
(30) 가

(21)가 (24) 2000-48562 6280442 가
(21)가 (24)

(24)
(non-self-tapping screw)

가

가

(57)

1. 가 , 가

1 2. 가

1 3.

1 4. 3 가 ,

- 4 5.
- 5 6.
- 6 7.

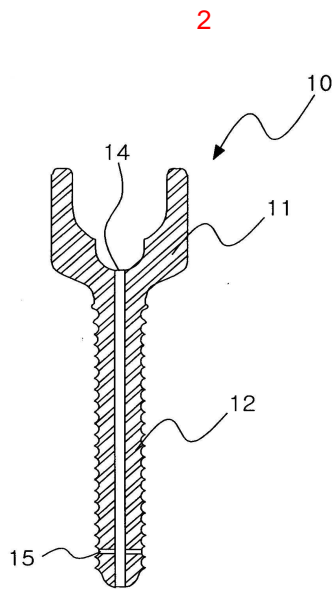
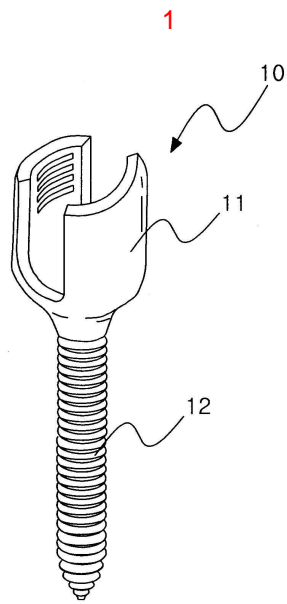

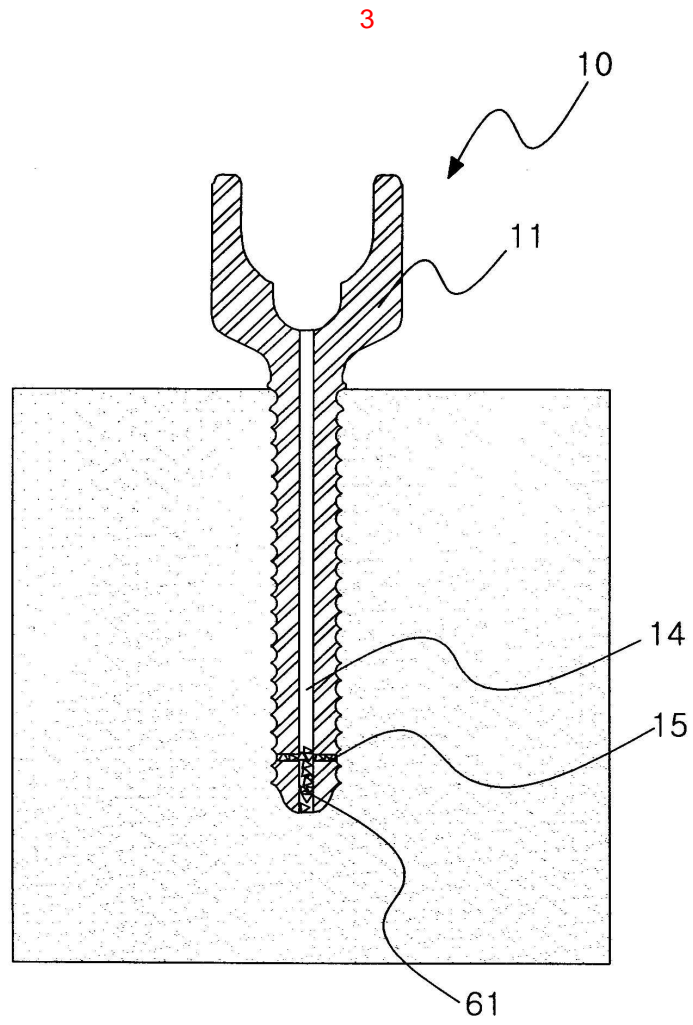

4

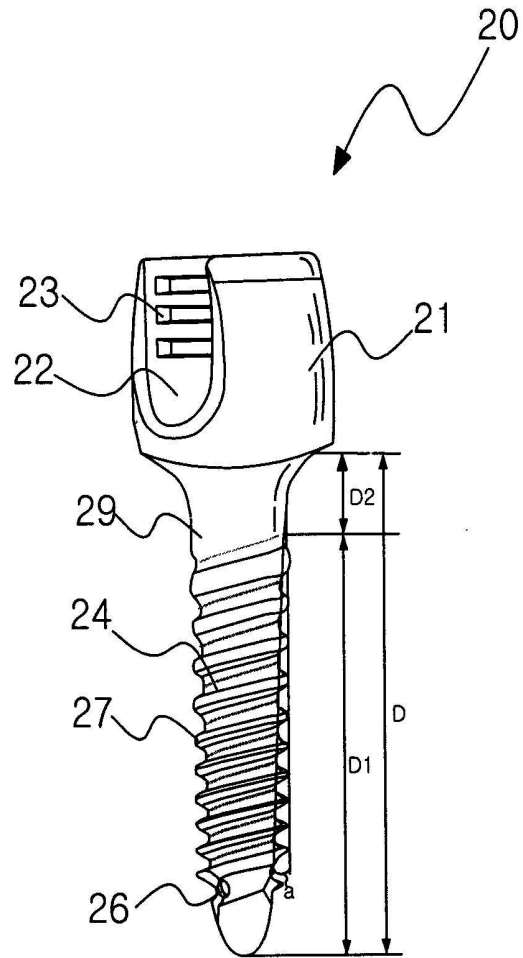

5

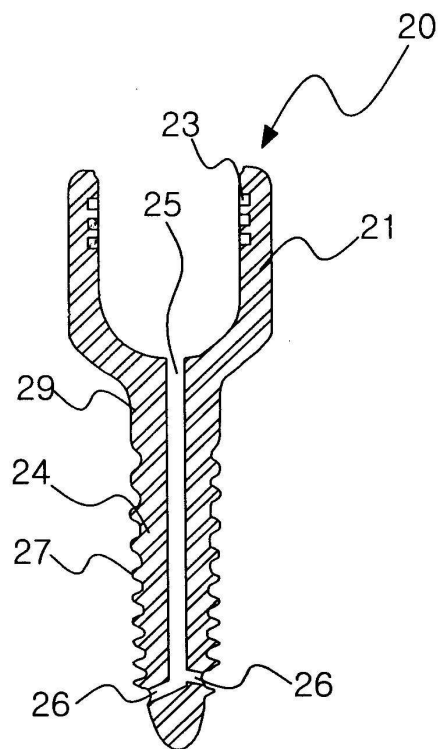

6

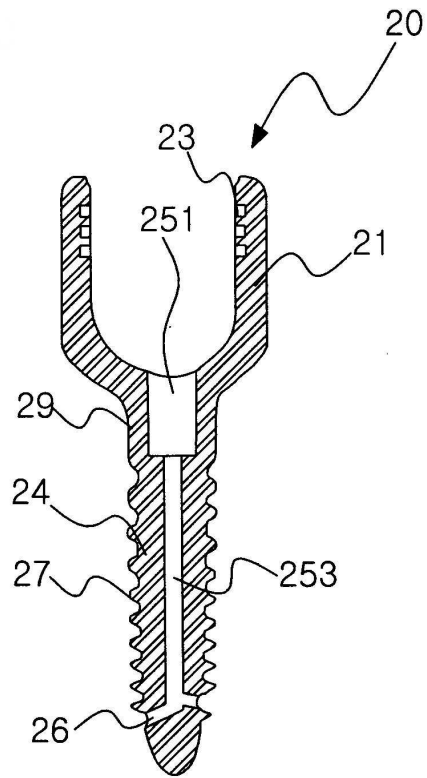

7

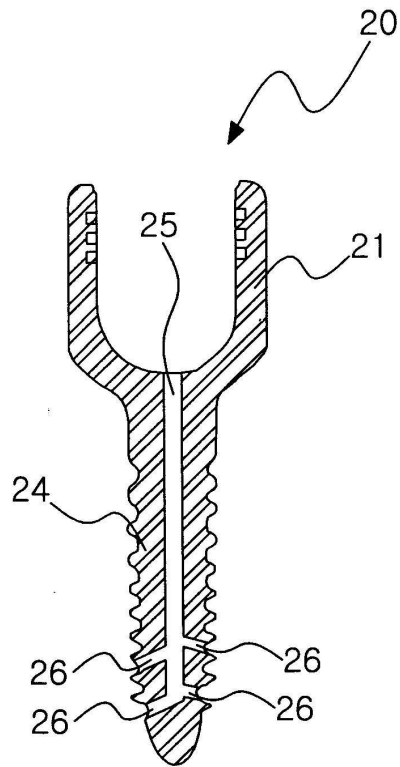

8

