

(19) AUSTRALIAN PATENT OFFICE

(54) Title
Washing machine

(51)⁶ International Patent Classification(s)
D06F 37/06 (2006.01) 20060101AFI2006040
D06F 37/06 8BMEP

(21) Application No: 2004203379 (22) Application Date: 2004 .07 .23

(30) Priority Data

(31) Number	(32) Date	(33) Country
P2003-0051958	2003 .07 .28	KR
P2003-0051959	2003 .07 .28	KR

(43) Publication Date : 2005 .02 .17
(43) Publication Journal Date : 2005 .02 .17

(71) Applicant(s)
LG Electronics Inc.

(72) Inventor(s)
Jung, Hye Sun, Shin, Soo Hee

(74) Agent/Attorney
Davies Collison Cave, 1 Nicholson Street, MELBOURNE, VIC, 3000

(56) Related Art
US 2004118168
SU 986993
DE 10260023

ABSTRACT OF THE DISCLOSURE

The present invention provides a washing machine, by which washing and dewatering capabilities are enhanced. The present invention includes a housing, a tub provided within the housing to reserve water therein, a drum rotatably provided within the tub to perform washing on a laundry therein, and at least one lifter projected on an inner circumference of the drum at a first predetermined height to lift the laundry to fall from a second predetermined height wherein the laundry is prevented from being stuck between one side of the at least one lifter and the drum.

FIG. 2

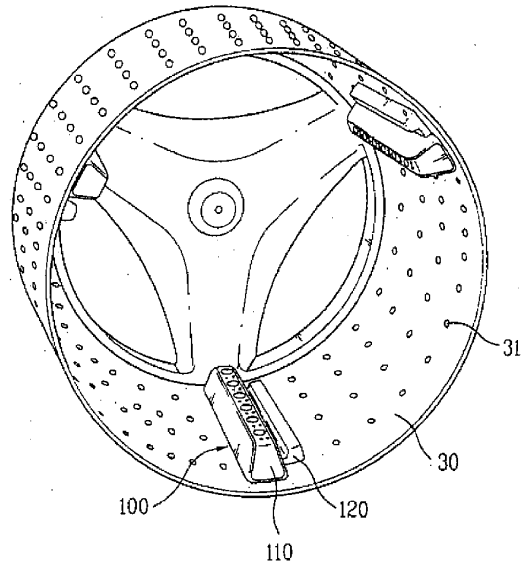

AUSTRALIA
PATENTS ACT 1990
COMPLETE SPECIFICATION

NAME OF APPLICANT(S)::

LG Electronics Inc.

ADDRESS FOR SERVICE:

DAVIES COLLISON CAVE
Patent Attorneys
1 Nicholson Street, Melbourne, 3000, Australia

INVENTION TITLE:

Washing machine

The following statement is a full description of this invention, including the best method of performing it known to me/us:-

5102

2004203379 15 Aug 2006

WASHING MACHINE

[0001] This application claims the benefit of Korean Applications Nos. P03-51958, filed on July 28, 2003, and P03-51959 filed on July 28, 2003 which are hereby incorporated by reference as if fully set forth herein.

[0002] The present invention relates to a washing machine, and more particularly, to a lifter installed in a drum of a washing machine.

[0003] Generally, a washing machine is an apparatus for washing a laundry by rotating a drum holding a detergent, water, and laundry therein. A washing machine generally includes a tub and a drum rotatably installed within the tub to perform washing using the tub and drum. The tub preliminarily stores water therein, and the drum to which the water and detergent are supplied is rotated together with the laundry therein. Moreover, a plurality of lifters are installed within the drum. The lifters rotating together with the drum lift the laundry to a predetermined height to drop. Besides, washing is performed on the laundry using the chemical reaction between the water and detergent as well as mechanical shock & friction by the drum and lifters.

[0004] In such a general washing machine, the drum is rotated at high speed when dewatering is performed on the laundry. A centrifugal force generated from the high-speed rotation makes the laundry adhere closely to an inner circumference of the drum uniformly.

[0005] However, the laundry tends to be stuck in a space between a side of the lifter and the inner circumference of the drum in the vicinity of the side of the lifter. In such a case, the laundry fails to be spread uniformly on the inner circumference of the drum but to be

2004203379 15 Aug 2006

raveled, whereby the watering fails to be completed. And, it is difficult to pull the raveled laundry out of the drum after completion of the dewatering.

[0006] Moreover, the drum is rotated at low speed during washing or rinsing cycle, whereby the laundry fails to be sufficiently contacted with both sides of the lifter. Hence, the friction generated between the laundry and the lifter is not enough to enhance washing performance.

[0007] Accordingly, the present invention is directed to a washing machine that substantially obviates one or more of the problems due to limitations and disadvantages of the related art.

10 [0008] Examples of the present invention seek to provide a washing machine, by which laundry is more uniformly spread on an inner circumference of a drum.

[0009] Additional features and advantages of the invention will be set forth in the description which follows, and in part will be apparent to those having ordinary skill in the art upon examination of the following or may be learned from a practice of the invention. The objectives and other advantages of the invention will be realized and attained by the subject matter particularly pointed out in the specification and claims hereof as well as in the appended drawings.

[0010] In accordance with the present invention there is provided a washing machine comprising:

- 20 a drum rotatably provided to perform washing on a laundry therein; and
- at least one lifter projected on an inner circumference of the drum to lift and drop the laundry wherein the lifter is configured so as to prevent the laundry from being stuck between one side of the at least one lifter and the drum.

[0011] The at least one lifter includes an extension extending from one of both lateral sides along the inner circumference of the drum. Preferably, the at least one lifter includes an extension extending from one of both lateral sides in a main rotational direction of the drum. Specifically, the main rotational direction of the drum is a rotational direction during dewatering.

[0012] The extension includes at least one hole communicating with at least one or more perforated holes of the drum to have the water flow in via the extension. Preferably, an entrance of the hole is configured not to be contacted with the laundry.

[0013] The extension includes tops and bottoms alternatively arranged on an upper end of the extension in a length direction of the extension. Preferably, the extension comprises an upper end having a wave shape. Preferably, the extension includes a plurality of holes formed in the bottoms to communicate with at least one or more perforated holes of the drum. Moreover, the extension includes at least one rib extending on an upper end of the extension in a length direction of the extension. Preferably, the extension includes a plurality of ribs extending in parallel on an upper end of the extension in a length direction of the extension. Preferably, the extension includes holes between a plurality of the ribs to communicate with at least one or more perforated holes of the drum. Besides, the extension includes a plurality of projections on an upper end of the extension to leave a predetermined interval from each other. And, the extension includes holes between a plurality of the projections to communicate with at least one or more perforated holes of the drum.

[0014] Moreover, a groove extends between the extension and the at least one lifter in a length direction of the extension or the at least one lifter.

[0015] Meanwhile, the at least one lifter includes at least one or more rotational

2004203379 15 Aug 2006

bodies rotatably installed to be contacted with the laundry. The at least one lifter includes at least one recess receiving the at least one rotational body therein to prevent the at least one rotational body from being separated from the at least one lifter. Moreover, the at least one lifter includes at least one hole communicating with at least one or more perforated holes of the drum to have the water flow in via the at least one lifter.

[0016] By the above-described present invention, the laundry avoids being stuck between the lateral side of the lifter and the inner circumference of the drum and is evenly spread on the inner circumference of the drum to be well dewatered. Moreover, the lifter has the increased contact area with the laundry, thereby enhancing washing capability.

[0017] It is to be understood that both the foregoing explanation and the following detailed description of the present invention are exemplary and illustrative and are intended to provide further explanation of the invention as claimed.

[0018] The invention is described, by way of non-limiting example only, with reference to the accompanying drawings, in which:

[0019] FIG. 1 is a cross-sectional diagram of a washing machine according to an example of the present invention;

[0020] FIG. 2 is a perspective diagram of a drum of a washing machine according to an example of the present invention;

[0021] FIG. 3A is a layout of a lifter of a washing machine according to an example of the present invention;

[0022] FIG. 3B and FIG. 3C are cross-sectional diagrams of the lifter bisected along cutting lines I-I and II-II in FIG. 3A, respectively;

[0023] FIG. 4A is a layout of a modified lifter body according to an example of the present invention;

2004203379 15 Aug 2006

[0024] FIG. 4B is a cross-sectional diagram of the modified lifter body bisected along a cutting line I-I in FIG. 4A;

[0025] FIG. 5A is a layout of another modified lifter body according to an example of the present invention;

5 [0026] FIG. 5B is a cross-sectional diagram of another modified lifter body bisected along a cutting line I-I in FIG. 5A;

[0027] FIG. 6A is a layout of a modified lifter extension according to an example of the present invention;

10 [0028] FIG. 6B and FIG. 6C are cross-sectional diagrams along cutting lines I-I and II-II in FIG. 6A, respectively;

[0029] FIG. 7A is a layout of another modified lifter extension according to an example of the present invention; and

[0030] FIG. 7B and FIG. 7C are cross-sectional diagrams along cutting lines I-I and II-II in FIG. 7A, respectively.

15

[0031] Reference will now be made in detail to examples of the present invention which are illustrated in the accompanying drawings. Throughout the drawings, like elements are indicated using the same or similar reference designations where possible.

20 [0032] FIG. 1 is a cross-sectional diagram of a washing machine according to the present invention. A washing machine according to the present invention is explained by

referring to FIG. 1 as follows. The washing machine shown in the drawing is a front-loading type having a horizontally laid tub and drum. The front-loading type washing machine has the similar structure of a top-loading type washing machine having an upright tub and drum.

[0033] Referring to FIG.1, a washing machine according to the present invention includes a housing 10, a tub 20 installed within the housing 10, and a drum 30 installed within the tub 20.

[0034] Various parts are installed within the housing 10 to be protected. A door 11 is provided to a front side of the housing 10 to be configured to open/close a housing opening 10a communicating with the drum 30. Specifically, the housing opening 10a communicates with a tub opening 20a and a drum opening 30a in turn to pit a laundry in the drum 30. And, a gasket 12 is provided between the housing opening 10a and the tub opening 20a to prevent water leakage. Moreover, a control panel 13 is installed on an upper part of the housing 10. A user instructs an operation of the washing machine using the control panel 13 and puts/pulls the laundry in/from the drum 30 using the door 11. The tub 20 reserves water therein to supply the water to the drum 30 uniformly on washing. A passing hole is formed in a bottom center of the tub 20, and a drive shaft 42 is connected to the drum 30 via the passing hole. The tub 20 includes a balance weight 21 and is elastically installed within the housing 10 using a damper 22 and a suspension spring 23. The drum 23 holds 30 a laundry therein and is rotatably installed within the tub 20. The drum 30 includes a multitude of perforated holes 31 via which water flows in the drum 30 and a lifter 100 for assisting washing. Meanwhile, a drive unit 40 is provided to the tub 20 to provide a drive force for rotating the drum 30. The drive unit 40 includes a motor 41 and the drive shaft 42 connecting the motor 41 to the drum 30. Specifically, the motor 41 includes a stator 41a fixed to a bottom side of the tub 20 and a rotor 41b rotatably installed to enclose the stator 41a. As the rotor 41b is directly connected to the drive shaft 42, the drive force of the motor 41 is directly transferred to the drum 30 via

the drive shaft 42 without loss of the drive force. Hence, the drive unit 40 is very advantageous in aspect of efficiency, noise, and vibration. Although not shown in the drawing, the drive unit 40 may include a general drive mechanism constructed with pulleys installed at the drum 30 and motor and a belt connecting the pulleys.

[0035] In the above-explained washing machine, the lifter (baffle) 100 is provided to an inner circumference of the drum 30 to protrude at a predetermined height. The drum 30 includes at least one or more lifters 100. The lifter 100 is prepared as a separate member to be installed in the drum 30 or may be built in one body of the drum 30 to protrude inward by 'pressing'. As the lifter 100 is projected, the laundry becomes caught on the lifter 100 while the drum 30 is rotated. The lifter 100 is rotated together with the drum 30 to lift the laundry to a predetermined height. The lifted laundry then falls from the lifter by gravity to collide with another laundry, water, drum 30, or another lifter 100. Moreover, the laundry becomes rubbed with the lifter 100 during the rotation of the drum 30. Hence, the laundry is more efficiently washed by the mechanical collision and friction. Besides, the lifter 100 additionally plays a role in stirring the laundry to aid the washing. The lifter 100 according to the present invention is explained in detail by referring to the attached drawings as follows.

[0036] FIG. 2 is a perspective diagram of a drum of a washing machine according to the present invention, FIG. 3A is a layout of a lifter of a washing machine according to the present invention, and FIG. 3B and FIG. 3C are cross-sectional diagrams of the lifter bisected along cutting lines I-I and II-II in FIG. 3A, respectively.

[0037] Referring to FIG. 2, a lifter 100 includes a main body 110 and an extension 120 connected to the main body 110.

[0038] The main body 110 approximately extends in parallel with a central axis of the drum 30 to be frequently contacted with the laundry. The main body 110 is preferably formed of a metal or synthetic resin based material that is resistant against corrosion and

abrasion due to water as well as fails to chemically react with a detergent. Moreover, at least one rotational body 111, as shown in FIG. 3A, is rotatably provided to the main body 110 to be partially projected from the main body 110 to be contacted with the laundry. The rotational body 111, as shown in FIG. 3B, is preferably a ball that is optimally rotatable. And, a plurality of rotational bodies 111, as shown in the drawings, are arranged along an upper end of the main body 110. Hence, each of the rotational bodies 111 becomes contacted with the laundry to rotate, whereby the corresponding laundry smoothly slides on the lifter 100. Consequently, the laundry avoids being raveled by the lifter 100 owing to the rotational bodies 111 so as not to be entangled with other laundries. Moreover, the laundry lifted by the lifter 100 is facilitated to slide to fall from the lifter at a predetermined height. Specifically, the main body 110 includes at least one recess 110a preventing the rotational body 111 from being detached from the main body 110. As mentioned in the forgoing description, in case that the main body 110 includes a plurality of the rotational bodies 111, a plurality of recesses 110a are arranged along the upper end of the main body 110. Moreover, in case that the rotational body 111 is the ball, the recess 110a preferably has a hemispherical shape to enable a smooth rotation of the rotational body 111 and to support a lower part of the rotational body 111 stably. Furthermore, the recess 110a can be processed to have a smooth surface or a separate lubricant coating can be formed on a surface of the recess 110a. The recesses 110a, as shown in the drawings, are built in one body of the main body 110. Instead, it is understandable that a separate panel (not shown in the drawings) including the recesses 110a is coupled to the upper part of the main body 110.

[0039] At least one hole 110b, as shown in FIG. 3B, is formed in the main body 110 to communicate with the perforated hole 31 of the drum 30. Hence, water held in the tub 20 flows in the drum 30 via the main body 110 using the perforated hole 31 and the hole 110b, whereby efficient water supply is achieved. For the purpose of more efficient water supply, a

multitude of holes 110b are formed in the main body 110. Since a sufficient space is needed to form the holes 110b, the holes 110b, as shown in FIG. 3A, are appropriately arranged between the rotational bodies 111. The holes 110b, as shown in FIG. 3A, can be arranged the spaces between the rotational bodies 111 in a length direction of the main body 110. Or, the holes 110b, as shown in FIG. 4A, may be arranged in a direction perpendicular to the length direction. Moreover, the holes 110b, as shown in FIG. 5A, can be arranged diagonally in the respective spaces between the rotational bodies 111. In this case, more holes can be provided to each of the spaces between the rotational bodies 111. Furthermore, rows of the diagonally arranged holes 110b, as shown in the drawing, can be zigzagged (staggered) from each other.

[0040] Referring to FIG. 4A, the main body 110 may further include a plate member 112 holding the rotational body 111 to prevent from being separated from the main body 110. The rotational body 111 can be more stably installed in the body 110 by the plate member 112. The plate member 112 is preferably formed of metal or synthetic resin. The plate member 112 is mounted on the upper end of the main body 110 like the rotational body 111 and includes the hole 112a to have the rotational body 111 fitted therein. As mentioned in the foregoing description, since the main body 110 includes a plurality of the rotational bodies 111, a plurality of holes 112a are provided to the plate member 112 to correspond to the rotational bodies 111, respectively. The holes 112a, as shown in FIG. 4B, are formed to confront the recesses 110a holding the rotational bodies 111, respectively. Each size of the holes 112a is smaller than that of the corresponding rotational body 111, whereby each of the holes 112a can hold the corresponding rotational body 111. And, auxiliary holes 112b are formed in each space between the holes 112a to communicate with the holes 110b of the main body 110, whereby the water is supplied to the drum 30 via the main body 110 from the tub 20. In case that the plate member 112 is projected from the main body 110, damage may be caused to the laundry during washing. Hence, the plate member 112 is preferably formed not

to be projected out of the main body 110. Specifically, a loading portion, as shown in FIG. 4B, is provided to the upper end of the main body 110 so that the plate member 112 can be loaded on the loading portion not to be projected. Alternatively, top portions 110c and bottom portions 110d, as shown in FIG. 5A and FIG. 5B, are formed on at least one side of the main body 110. The top and bottom portions 110c and 110d are alternately arranged in a length direction of the main body 110. The top and bottom portions 110c and 110d increase a contact area of the lifter 100 with the laundry, thereby enhancing washing performance of the washing machine. Thus, the top and bottom portions 110c and 110d are preferably formed on both lateral sides of the main body 110. More preferably, the top and bottom portions 110c and 110d are formed smooth not to cause damage to the laundry. In such a case, each of the lateral sides of the main body 110 has a wave shape. Moreover, the rotational bodies 111 relatively need more space than the holes 110b, whereby each of the corresponding rotational bodies 111 is provided between a pair of the corresponding top portions 110c of both of the lateral sides of the main body 110 and the holes 110b are provided between a pair of the corresponding bottom portions 110d of both of the lateral sides of the main body 110.

[0041] Referring to FIG. 3A, the extension 120 extends from one of both of the lateral sides of the main body 110 along the inner circumference of the drum 30. The drum 30 is rotatably configured in both forward and reverse directions, i.e. a first direction and a second direction opposite to the first direction. Yet, the drum 30 tends to mostly rotate in one of the first and second directions through the entire cycles of washing, rinsing, and dewatering. The laundry is mainly contacted with the lifter 100, and more accurately, with one of both of the lateral sides of the main body 110 oriented in the main rotational direction, thereby becoming stuck in a gap between the corresponding lateral side of the main body 110 and the inner circumference of the drum 30. In order to prevent the laundry from being stuck in the corresponding gap, the extension 120 preferably extends from one of the both of the

lateral sides of the main body 110 in the main rotational direction of the drum 30. Moreover, even if the drum 30 is alternately rotated in the first or second direction during washing or rinsing, the drum 30 is rotated at high speed in either the first direction or the second direction during dewatering, whereby the laundry is badly stuck in the gap between the corresponding lateral side of the main body 110 and the inner circumference of the drum 30. Most preferably, the extension 120 extends from the main body 110 in the rotational direction of the drum 30 for dewatering. Besides, even if the main rotational direction is different from the rotational direction of dewatering, the extension 120 extends in the rotational direction of dewatering to be more effective in preventing the laundry from being stuck in the gap between the lateral side of the main body 110 and the inner circumference of the drum 30. Alternatively, in order to completely prevent the laundry from being stuck in the gap between the lateral side of the main body 110 and the inner circumference of the drum 30, the lifter 100 may include a pair of extensions 120 extending from both of the lateral sides of the main body 110 along the inner circumference of the drum 30, respectively.

[0042] Specifically, the extension 120, as shown in the drawings, is shorter than the lifter 100, i.e., the main body 110. Yet, the extension 120 can be formed longer than the main body 100 if necessary. If the extension 120 is formed higher than the main body 110, the main body 110, and more particularly, the rotational body 111 is unable to perform its function appropriately. Hence, the upper end of the extension 120, as shown in FIG. 3B is provided lower than that of the main body 110 and is properly placed at about a half of height of the main body 110. And, a lower end of the extension 120 is contacted with the inner circumference of the drum 30. Namely, the extension 120 extends from the inner circumference of the drum like the main body 10 but has height smaller than that of the main body 110. The height of the extension 120 is adjustable if necessary. Thus, the lifter 100 according to the present invention covers the predetermined gap between the lateral side of

the main body and the inner circumference of the drum 30. Furthermore, the lifter 100, and more particularly, the extension 120 substantially fills up the predetermined gap between the lateral side of the main body and the inner circumference of the drum 30. Hence, the lifter 100 isolates the predetermined gap from other inner space of the drum 30, thereby enabling to cut off the access of the laundry to the predetermined gap. Consequently, the lifter 100 according to the present invention effectively prevents the laundry from being struck between the lateral side of the main body 110 and the adjacent inner circumference of the drum 30.

[0043] At least one or more holes 121, as shown in Fig. 3B, are formed in the extension 120 to communicate with the perforated holes 31 of the drum 30. Hence, the water in the tub 2 can flow in the drum 30 via the extension 120 using the perforated holes 31 and the holes 121 of the extension 120. Hence, the water can be supplied to drum 30 via the overall lifter 100, whereby water supply is efficiently performed. A plurality of the holes 121 are preferably formed in the extension 122 for the more efficient water supply. Moreover, a groove 122 is provided between the extension 120 and the main body 110 in the length direction. A lateral side, as clearly shown in FIG. 3B, is formed on the extension 120 by the groove 122 to increase the corresponding lateral side of the main body 110. Hence, the extension 120 and main body 110 basically have the increased contact area with the laundry. Besides, the groove 122 plays a role in draining the water from the lifter 100 smoothly as well.

[0044] The lifter 100 including the extension 120 secures the increased contact area with the laundry to increase the friction thereof, thereby enabling to enhance washing capability. In order to enhance the washing capability higher, the extension 120 is preferably configured to increase the contact area with the laundry more. For this, the extension 120 is configured to protrude in part. Specifically, top portions 120a and bottom portions 120b, as shown in FIGs. 3A to 3C, are formed on the upper end of the extension 120. The top and

bottom portions 120a and 120b are alternately arranged in the length direction of the extension 120. Preferably, the top and bottom portions 120a and 120b are formed smooth not to cause damage to the laundry. In such a case, the upper end of the extension 120 has a wave shape. The top and bottom portions 120a and 120b are identically shown in FIGs. 4A to 5B as well. Alternatively, at least one or more ribs 123, as shown in FIGs. 6A to 6C, can be formed on the upper end of the extension 120 to extend in the length direction of the extension 120. Preferably, a plurality of the ribs 123 are provided to the upper end of the extension 120 in parallel with other. Yet, since a size of the upper end of the extension 120 is not sufficient, a pair of the ribs 123, as shown in the drawings, are preferably formed on the upper end of the extension 120. Meanwhile, the extension 120, as shown in FIGs. 7A to 7B, may include a plurality of projections 124 formed on its upper end to leave a predetermined interval from each other. The projections 124 are preferably arranged on the upper end of the extension 120 in the length direction of the extension 120 to be evenly contacted with the laundry.

[0045] Meanwhile, a burr may be formed in the vicinity of an entrance of the hole 121 in forming the holes 121. And, damage may be caused to the laundry by the burrs. Specifically, the drum 30 is rotated at high speed in the early stage of dewatering so that the laundry vigorously moves. Hence, it is highly probable that such damage will be caused to the laundry. Preferably, the entrances of the holes 121 are configured not to be contacted with the laundry. The holes 121 are substantially located between the projected portions 120a, 123, or 124. Specifically, the holes 121, as shown in FIG. 3A and FIG. 3C, are formed between the top portions 120a, i.e., on the bottom portions 120b. And, the holes 121, as shown in FIG. 6A and FIG. 6C, are formed between the ribs 123. Moreover, the holes 121, as shown in FIG. 7A and FIG. 7C, are formed between the projections 124. Even if the holes 121 are processed rough, the damage caused to the laundry can be minimized.

[0046] Accordingly, the washing machine according to the present invention has the following advantages or effects.

[0047] First of all, the extension prevents the laundry from being entangled or stuck between the lateral side of the main body and the inner circumference of the drum, specifically during dewatering. Hence, the laundry or laundries are evenly spread on the inner circumference of the drum to be properly dewatered. And, a user is facilitated to pull the laundries out of the drum after completion of dewatering.

[0048] Secondly, the lifter prevents the laundry from being entangled with other using the rotational body and has the increased contact area with the laundry using its structural modifications. Therefore, the lifter can be more rubbed with the laundry to enhance washing capability.

[0049] Finally, the enhancement of the dewatering and washing capabilities increases user's reliance on the washing machine.

[0050] It will be apparent to those skilled in the art that various modifications and variations can be made in the present invention without departing from the spirit or scope of the invention. Thus, it is intended that the present invention cover such modifications and variations, provided they come within the scope of the appended claims and their equivalents.

Throughout this specification and the claims which follow, unless the context requires otherwise, the word "comprise", and variations such as "comprises" and "comprising", will be understood to imply the inclusion of a stated integer or step or group of integers or steps but not the exclusion of any other integer or step or group of integers or steps.

The reference to any prior art in this specification is not, and should not be taken as, an acknowledgement or any form of suggestion that that prior art forms part of the common general knowledge in Australia.

2004203379 15 Aug 2006

THE CLAIMS DEFINING THE INVENTION ARE AS FOLLOWS:

1. A washing machine comprising:
5 a drum rotatably provided to perform washing on a laundry therein; and
at least one lifter projected on an inner circumference of the drum to lift and drop the
laundry wherein the lifter is configured so as to prevent the laundry from being stuck between
one side of the at least one lifter and the drum.
- 10 2. The washing machine of claim 1, wherein the at least one lifter prevents the
laundry from accessing a gap between the lateral side of the lifter and the inner circumference
of the drum.
3. The washing machine of claim 1, wherein the at least one lifter isolates a gap
15 between the lateral side of the lifter and the inner circumference of the drum from an inner
space of the drum.
4. The washing machine of claim 1, wherein the at least one lifter is configured
to cover a gap between the lateral side of the lifter and the inner circumference of the drum.
- 20 5. The washing machine of claim 1, wherein the at least one lifter is configured
to fill up a gap between the lateral side of the lifter and the inner circumference of the drum.

6. The washing machine of claim 1, wherein the at least one lifter is configured to increase a contact area with the laundry.

7. The washing machine of claim 1, wherein the at least one lifter comprises an extension extending from one of both lateral sides along the inner circumference of the drum.

8. The washing machine of claim 1, wherein the at least one lifter comprises extensions extending from both lateral sides along the inner circumference of the drum, respectively.

9. The washing machine of claim 1, wherein the at least one lifter comprises an extension extending from one of both lateral sides in a main rotational direction of the drum.

10. The washing machine of claim 9, wherein the main rotational direction of the drum is a rotational direction during dewatering.

11. The washing machine of claim 8, wherein the extension is shorter than the at least one lifter.

12. The washing machine of claim 8, wherein an upper end of the extension is lower than an upper end of the lifter.

13. The washing machine of claim 8, wherein an upper end of the extension is located at a half of a height of the lifter.

14. The washing machine of claim 8, wherein a lower end of the extension is contacted with the inner circumference of the drum.

15. The washing machine of claim 8, wherein the extension comprises at least one hole communicating with at least one or more perforated holes of the drum to have the water flow in via the extension.

16. The washing machine of claim 15, wherein an entrance of the hole is configured not to be contacted with the laundry.

17. The washing machine of claim 8, wherein the extension is configured to increase a contact area with the laundry.

18. The washing machine of claim 8, wherein the extension is configured to protrude in part.

19. The washing machine of claim 18, wherein the extension comprises at least one hole between protrusions of the extension to communicate with at least one or more perforated holes of the drum.

20. The washing machine of claim 8, wherein the extension comprises tops and bottoms alternatively arranged on an upper end of the extension in a length direction of the extension.

21. The washing machine of claim 8, wherein the extension comprises an upper end having a wave shape.

22. The washing machine of claim 20, wherein the extension comprises a plurality of holes formed in the bottoms to communicate with at least one or more perforated holes of the drum.

23. The washing machine of claim 8, wherein the extension comprises at least one rib extending on an upper end of the extension in a length direction of the extension.

24. The washing machine of claim 8, wherein the extension comprises a plurality of ribs extending in parallel on an upper end of the extension in a length direction of the extension.

25. The washing machine of claim 24, wherein the extension comprises holes between a plurality of the ribs to communicate with at least one or more perforated holes of the drum.

26. The washing machine of claim 8, wherein the extension comprises a plurality of projections on an upper end of the extension to leave a predetermined interval from each other.

27. The washing machine of claim 26, wherein the extension comprises holes between a plurality of the projections to communicate with at least one or more perforated holes of the drum.

28. The washing machine of claim 8, wherein a groove extends between the extension and the at least one lifter in a length direction of the extension or the at least one lifter.

29. The washing machine of claim 1, wherein the at least one lifter is configured to have the laundry slide thereon.

30. The washing machine of claim 1, wherein the at least one lifter comprises at least one or more rotational bodies rotatably installed to be contacted with the laundry.

31. The washing machine of claim 30, wherein the at least one rotational body is a ball.

32. The washing machine of claim 30, wherein a plurality of rotational bodies are arranged along an upper end of the at least one lifter.

33. The washing machine of claim 30, wherein the at least one lifter comprises at least one recess receiving the at least one rotational body therein to prevent the at least one rotational body from being separated from the at least one lifter.

34. The washing machine of claim 30, wherein the at least one lifter further comprises a plate installed on a surface of the at least one lifter to hold the at least one rotational body to prevent the at least one rotational body from being separated from the at least one lifter.

35. The washing machine of claim 34, wherein the plate comprises at least one hole having a size smaller than that of the at least one rotational body to have the at least one rotational body fitted therein.

36. The washing machine of claim 34, wherein the plate is installed not to be projected from the at least one lifter.

37. The washing machine of claim 1, wherein the at least one lifter comprises at least one hole communicating with at least one or more perforated holes of the drum to have the water flow in via the at least one lifter.

38. The washing machine of claim 30, wherein the at least one lifter comprises a plurality of holes between the rotational bodies to communicate with at least one or more perforated holes of the drum.

39. The washing machine of claim 38, wherein a plurality of the holes are arranged in a row between the rotational bodies.

40. The washing machine of claim 38, wherein a plurality of the holes are diagonally arranged in each space between the rotational bodies.

41. The washing machine of claim 1, wherein the at least one lifter comprises tops and bottoms formed on at least one lateral side to be alternately arranged in a length direction of the at least one lifter.

2004203379 15 Aug 2006

42. The washing machine of claim 1, wherein at least one lateral side of the at least one lifter is wave-shaped.

43. A washing machine substantially as hereinbefore described with reference to
5 the drawings.

10

Dated this 10th day of August, 2006

LG Electronics Inc.

by DAVIES COLLISON CAVE
Patent Attorneys for the applicant(s)

FIG. 1

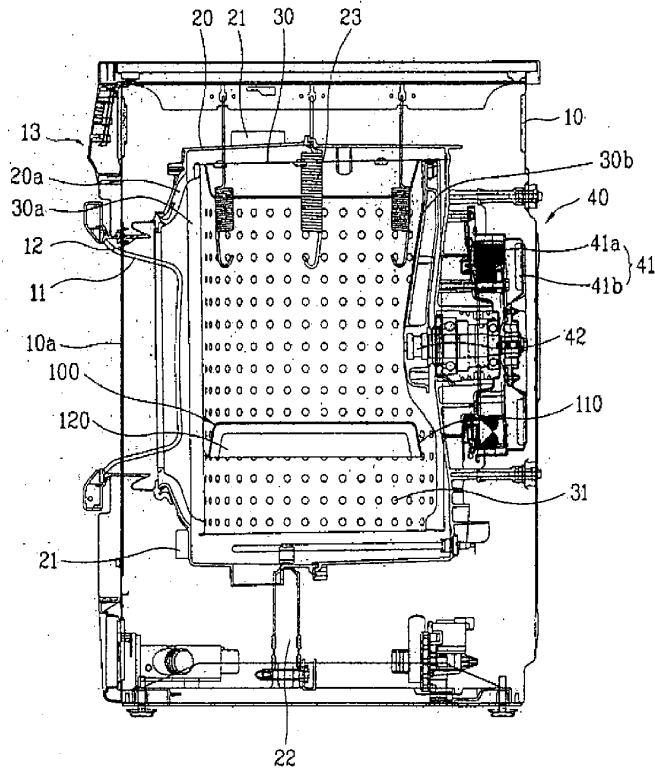

FIG. 2

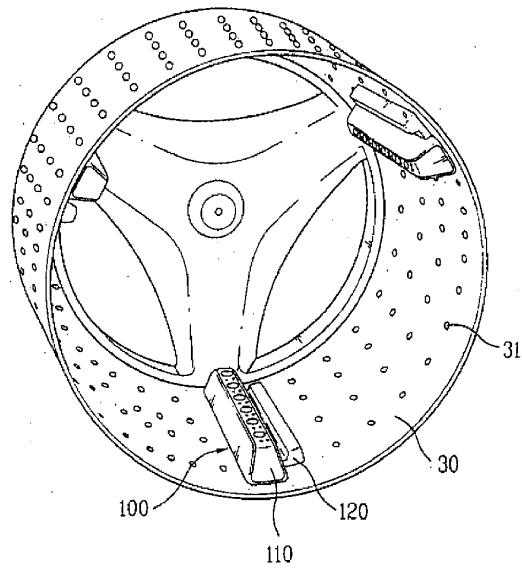

FIG. 3A

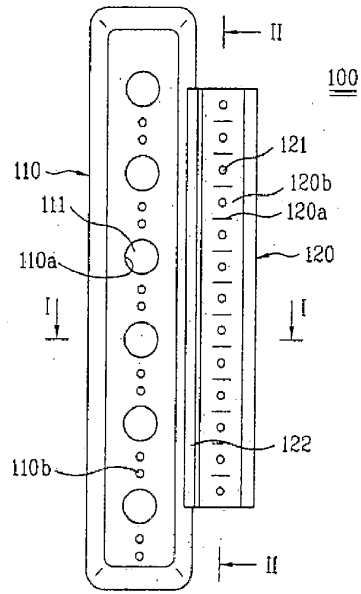

FIG. 3B

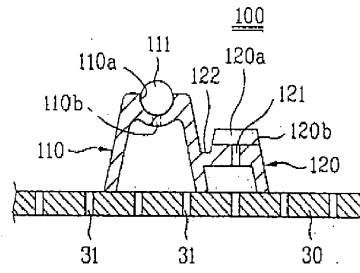

FIG. 3C

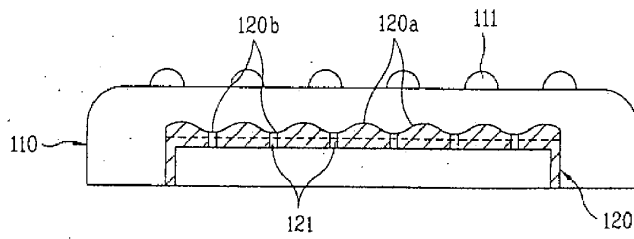

FIG. 4A

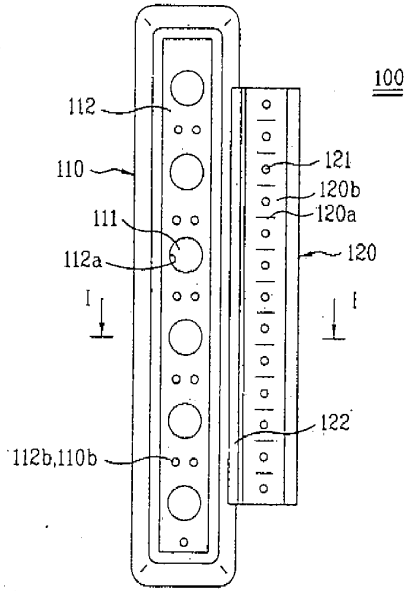

FIG. 4B

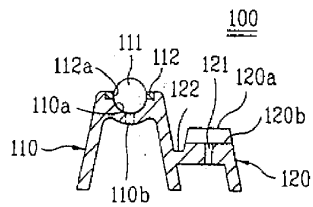

FIG. 5A

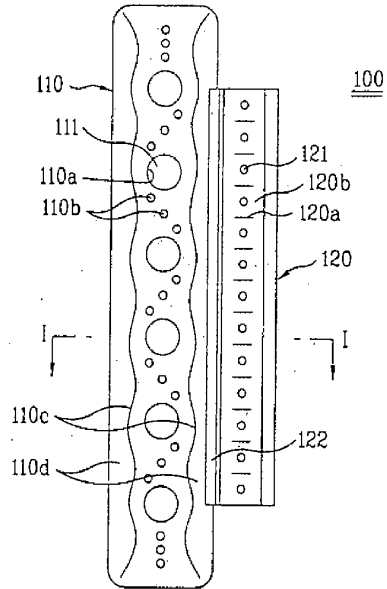

FIG. 5B

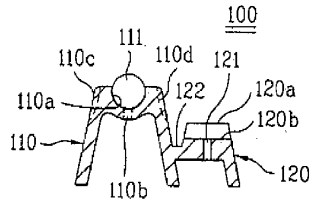

FIG. 6A

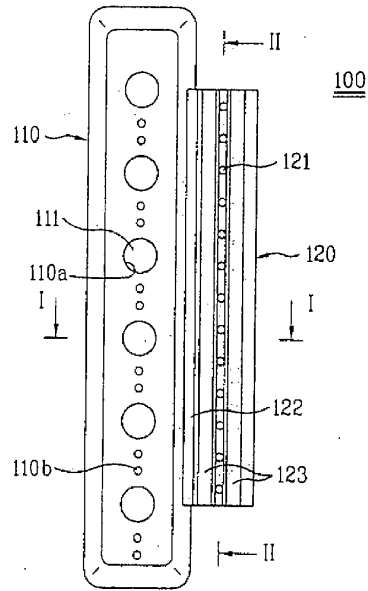

FIG. 6B

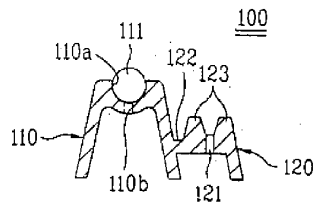

FIG. 6C

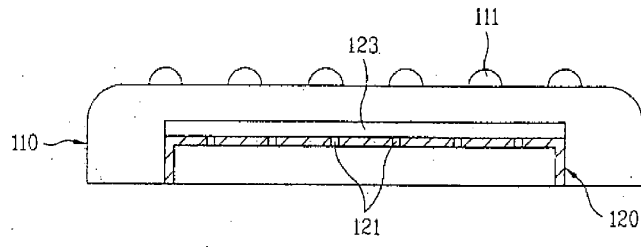

FIG. 7A

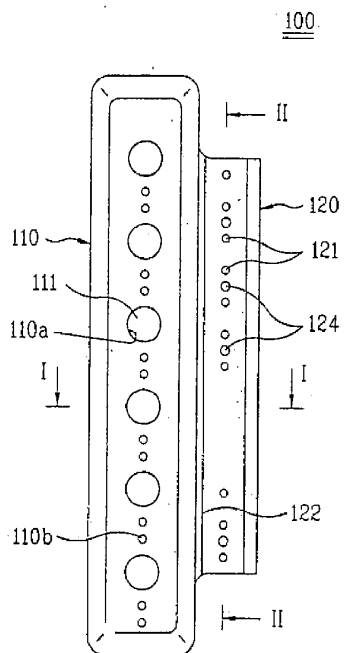

FIG. 7B

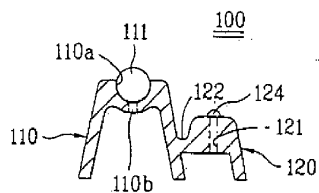

FIG. 7C

