

(No Model.)

J. T. SMITH.
JOURNAL BOX.

No. 451,007.

Patented Apr. 21, 1891.

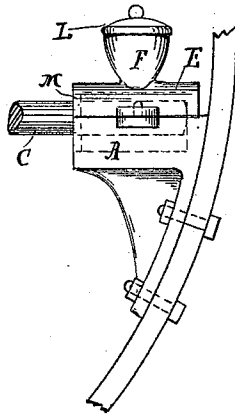

Fig. 1.

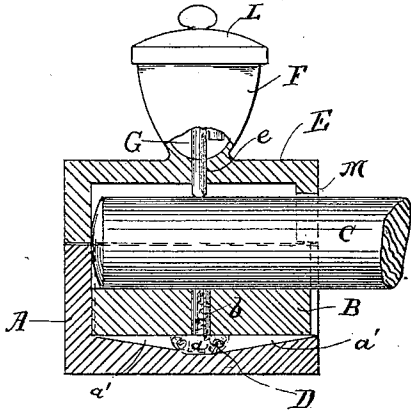

Fig. 2.

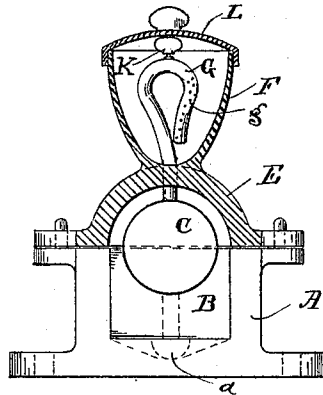

Fig. 3.

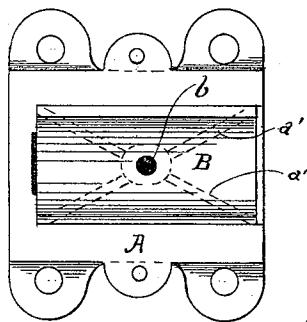

Fig. 4.

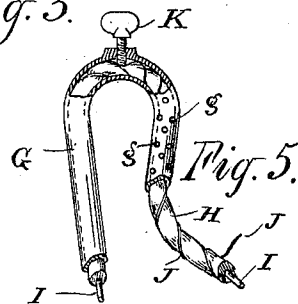

Fig. 5.

Witnesses.

H. Monteverde.

R. C. Strain

Inventor.

John T. Smith
by *A. H. La Marie*
att'y

UNITED STATES PATENT OFFICE.

JOHN T. SMITH, OF SAN FRANCISCO, CALIFORNIA.

JOURNAL-BOX.

SPECIFICATION forming part of Letters Patent No. 451,007, dated April 21, 1891.

Application filed June 16, 1890. Serial No. 355,604. (No model.)

To all whom it may concern:

Be it known that I, JOHN T. SMITH, a citizen of the United States, residing in the city and county of San Francisco, and State of California, have invented a new and useful Improvement in Journal-Boxes, of which the following is a specification.

My invention relates more particularly to journal-boxes used in connection with the cable-supporting pulleys of cable railways; and it has for its object to provide a smoother and more lasting journal-bearing than has been heretofore in use, together with improved means of lubrication, which will tend to greater economy in the distribution of the lubricant.

The above-entitled improvement consists of peculiar details of construction and certain combinations of parts, which I will now proceed to describe with reference to the appended drawings, which form part of this specification.

Figure 1 is a side elevation of my improved journal-box as it appears when attached to the tunnel-yokes or frame-work of a cable railway; Fig. 2, a central sectional elevation; Fig. 3, an end elevation, partly in section, with the dust-guard removed; Fig. 4, a plan of the pillow-block and journal-bearing, and Fig. 5 a detail view of part of the oiling device connected with the box.

Like letters of reference designate similar parts in the several views.

A represents the lower part of the box or pillow-block, which may be set at any desirable point in the cable-tunnel, either on a separate support or on a bracket secured to one of the tunnel-yokes, as illustrated in Fig. 1. A central cavity *a* is formed at the bottom of A in the inside to provide a receptacle for escaping oil, and to this converge oil-grooves *a'*, leading from the four corners of the pillow-block.

Within the part A, I place the journal-bearing B, which consists of a small block shaped so as to fit in the lower part of the box and hollowed out to receive the end of the shaft or spindle C of the cable-supporting sheaves. (Not shown.) This bearing may be made of various materials, such as Babbitt metal or brass; but I prefer to make it of glass, which possesses the advantage of presenting a very smooth surface well suited for a journal-bearing.

It is provided with a central opening *b*, corresponding to the cavity *a*, above mentioned, and filled with wool packing or some similar permeable substance D.

The journal of the shaft is made preferably of tempered steel, as this metal is likely to produce less friction with the glass bearing than other material. The end of the journal is also rounded, as will be noticed by reference to Fig. 2, to avoid friction with the rear wall of the pillow-block, or at least reduce it to a minimum. Above the journal is set the cap E, which is firmly secured to the lower part of the box by bolts or equivalent means.

F is a cup or vessel resting upon the top of the cap and adapted to hold oil or some other lubricant. By preference it is cast integral with the cap to avoid fitting and guard against its displacement through an accidental surging of the cable.

Both the cup F and cap E are provided with a hole *e*, through which the lubricant may reach the journal. If oil be used, it is better conveyed to the journal by means of a siphon G, the longer branch of which is fitted in and passes through the hole *e*. The interior of G (see Fig. 5) is filled with a packing of wool or other permeable material H, through which the oil has to pass. Thus it is filtered and its flow moderated. A metallic core I is embedded in the packing H, in order to transmit the heat caused by the revolution of the journal to the oil, and thereby prevent it from congealing in cold or frosty weather. For the same purpose a wire J is wound about the packing H, of which it also facilitates the insertion into the siphon G. Perforations *g* are made in the sides of the shorter branch of G to allow the oil to rise more freely into it. Above these perforations I provide a thumb-screw K, fitted in a suitable seat upon the upper part of the siphon and adapted to compress the filling material within it. By this means one is enabled to narrow the passage for the oil and graduate its feed to suit. A cover L is placed over the top of the oil-vessel to prevent any dust from getting into it.

M is a guard or protector, which I use to prevent dust or grit from getting into the box through its front end, and consequently injuring the journal or bearing. This guard may be made of any suitable material, such

as leather, rubber, wood, or metal. It forms a collar snugly fitting around the pulley-spindle, and, besides keeping off dirt, materially helps in preventing the escape of oil from the
5 box.

It will be observed from the nature of the elements above enumerated and their peculiar combination that little or none of the lubricant will be fed to the journal unless the pulleys be in motion and produce sufficient heat to attract it. This insures a great saving in the cost of lubrication over the system heretofore in vogue. The economy is still further carried out, however, since the lubricant when
10 flows is prevented from running off the box by the rear wall of the latter and the guard M, and returned to the journal through the grooves *a'*, the cavity *a*, the opening *b*, and the packing D.

Although especially adapted for the cable-supporting sheaves of cable railways, my improved box may be used in many other relations with a few modifications. Thus it may be applied to ordinary shafting, to the axles
15 of railway-trucks, and wherever a smooth hard bearing and an economical method of lubrication are desired.

The oil-vessel F, hereinbefore described, is thought to be the best for use in connection
30 with my improved journal-box; but the lubricating-cups and oilers shown in my patents, No. 306,542, of October 14, 1884, and No. 365,153, of June 21, 1887, might also be employed with advantage, and I therefore do

not wish to confine myself to the use of one to the exclusion of the others. 35

I am aware that it is not new to provide a journal-box with an oil-reservoir having passages leading thereto in connection with a packing of permeable material connecting
40 with said reservoir, whereby the shaft as it rotates is constantly supplied with the lubricant at every point of the bearing, and I therefore do not claim this construction broadly; but 45

What I do claim, and desire to secure by Letters Patent of the United States, is—

In a journal-box, the combination of a pillow box or block consisting of upper and lower sections, said upper section having an
50 oil-cup formed integral therewith and the lower section provided with central cavity and oil-grooves converging thereto from the four corners thereof, a journal-bearing provided with a central vertical opening com- 55
municating with the cavity of the lower section, packing of permeable material within the opening, and a siphon within the oil-cup having its longer arm passing through an opening in the upper section of the pillow-
60 box, so as to convey the lubricant to the shaft, substantially as set forth.

In testimony whereof I have hereunto set my hand and seal in presence of two witnesses.

JOHN T. SMITH. [L. S.]

In presence of—

J. W. CRITER,

ALVAN FLANDERS.