

(No Model.)

2 Sheets—Sheet 1.

P. DE SUSINI. ETHER VAPOR MOTOR.

No. 514,573.

Patented Feb. 13, 1894.

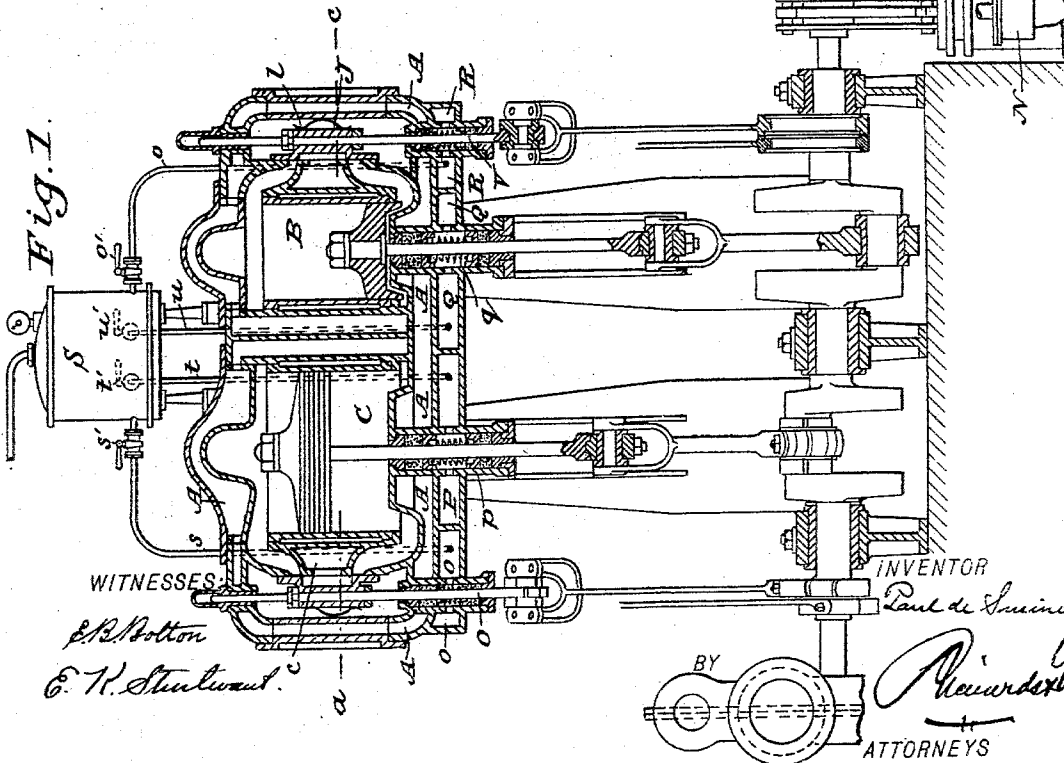
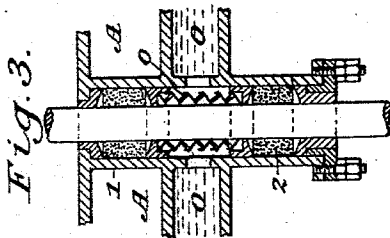
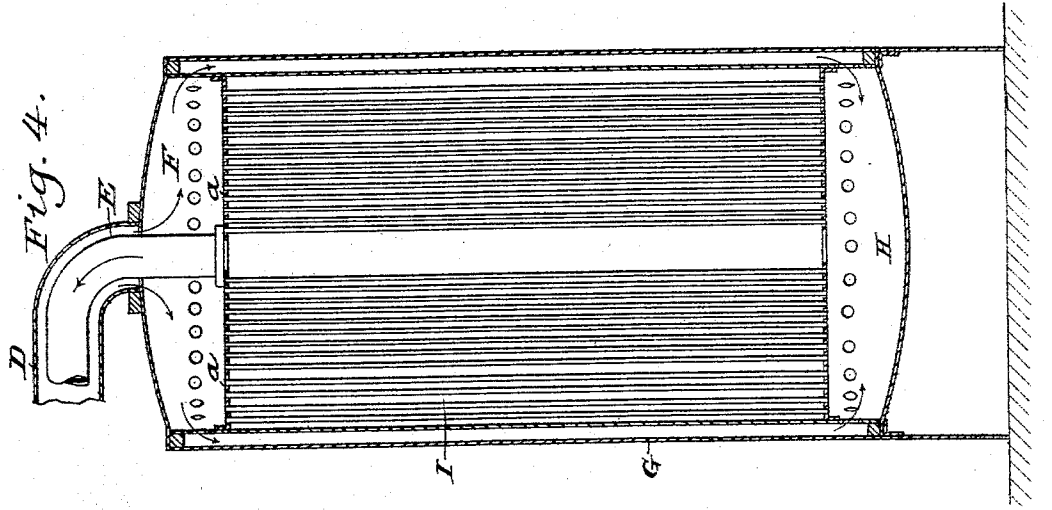

(No Model.)

2 Sheets--Sheet 2.

P. DE SUSINI.
ETHER VAPOR MOTOR.

No. 514,573.

Patented Feb. 13, 1894.

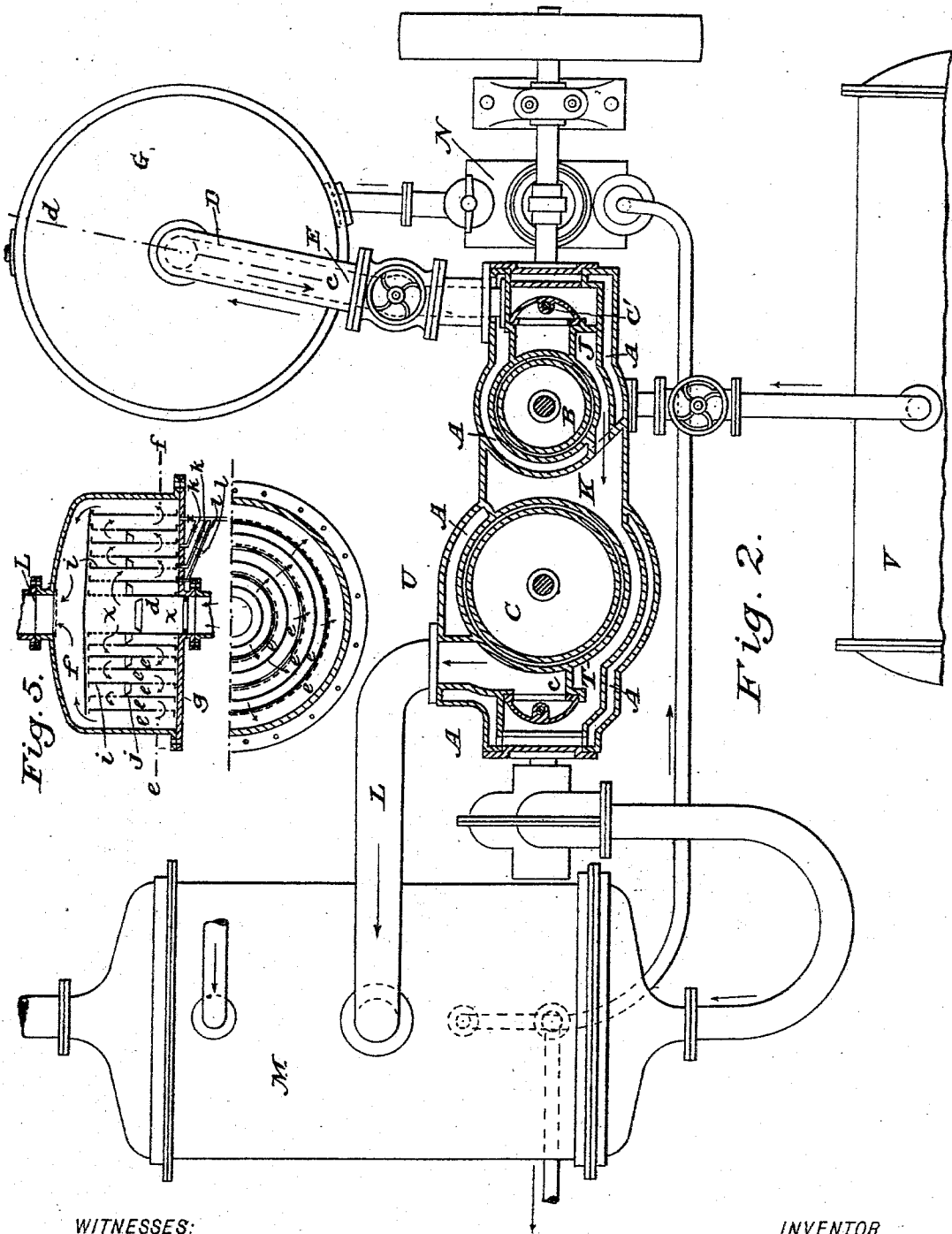

WITNESSES:

C. B. Bolton
E. T. Stoutenart

INVENTOR

Paul de Susini
BY *Richardson*
ATTORNEYS

UNITED STATES PATENT OFFICE.

PAUL DE SUSINI, OF PARIS, FRANCE.

ETHER-VAPOR MOTOR.

SPECIFICATION forming part of Letters Patent No. 514,573, dated February 13, 1894.

Application filed December 19, 1892. Serial No. 455,668. (No model.)

To all whom it may concern:

Be it known that I, PAUL DE SUSINI, a citizen of the French Republic, residing at Paris, France, have invented a new and useful Improvement in Ether-Vapor Motors, of which the following is a specification.

My apparatus includes a vapor generator heated by steam conveyed from a distance and derived from any suitable source, such as the exhaust of an engine or from a boiler placed in a suitable flue to be heated by waste heat from a furnace, the steam being conveyed to the generator after having first heated the jacket of the vapor engine to prevent condensation of the ether vapor.

My invention also includes an oil reservoir combined with a special form of stuffing box and with a receiver for the ether vapor which may escape through the said stuffing boxes and it includes also details hereinafter set forth.

In the drawings—Figure 1. of annexed drawings shows my new motor in elevation and a section of the same through the axes of the cylinders. Fig. 2. represents a plan view of a section on *a. b.* Fig. 3. shows in section the new stuffing box used in this motor. Fig. 4. shows a section on line *c. d.* of the generator or vaporizer. Fig. 5. shows a sectional view of my new separator for the lubricating matter.

A steam boiler of any kind, V. heated in the ordinary way and at some distance from the vaporizer or generator supplies steam to the jackets A of the cylinders B and C in which the vapor of ether works with double expansion. After having circulated through the jackets A the steam passes out through a pipe D which surrounds the vapor pipe E and into the upper chamber F of the vapor generator G to pass farther into the tubes *a.* and from there into the lower chamber H and also into the jacket I of the generator. The space between the chambers F and H and the jacket I contains the ether which is to be vaporized and through which all the tubes *a* run. The steam circulates through these tubes and the jackets and imparts all its caloric to the ether which then vaporizes. The vapor of ether thus generated passes through the conducting pipe E to the slide valve B' of the small cylinder B and then, after having worked with a first expansion it passes through the

conducting part J of the steam jacket to the space K to feed the slide valve *c* of the large cylinder C where the ether vapor works with a second expansion to escape then through the pipe L to the condenser with a surface of whatever kind, which works by water or moist air, passing into the separator U. The escaping vapor of ether of the large cylinder reaches the extremity of the conducting pipes L at X where it finds no other outlet than through the meshes (more or less large) of several superposed metallic or other sieves *x.* In consequence of the friction of the vapor of ether against these meshes a certain quantity of the lubricating matter adheres to the threads of the meshes and runs outside of L in one of the annular parts of the separator U in consequence of the presence of a conical groove inside of L. Coming out of the meshes *x* the vapor enters a series of annular spaces *e* formed by the covers *f* and *g* of the separator and by the circular plates *h* whether joined or not. The connection between the spaces is made so that the ether vapor must pass through the entire elevation of the annular spaces *e* going up and down alternately and coming in contact with the walls of said spaces. This contact will cause the vapor of ether to deposit a certain quantity of lubricating matter upon the sheet iron *h* and this lubricating matter will run off along the walls upon the inferior cover *g.* The metallic or other meshes which are placed between the spaces have no other object than to compel the ether to abandon the lubricating matter. On leaving the last space, the ether vapor which is now almost rid of its lubricating matter, goes to the other part of the pipe L which is fixed upon the condenser, in order to reach the same, passing again through tissues placed at the entrance of L as shown in dotted lines of Fig. 5. The lubricating matter it still contains is caught here and will run off to the conical cap *f,* to fall into the outer space of the separator.

In order to prevent the lubricating matter deposited at the bottom of the annular spaces to come up again along the circular walls which could happen in consequence of the rapidity wherewith the ether vapor rushes off, I have provided small inclined flanges which retain the lubricating matter at the entrance

of the metallic meshes and facilitates the running off of the part which has been abandoned upon the meshes. In order to prevent the lubrication matter which falls under the top cap *f* from coming again into the pipe L, I put a cone there, which guides the lubricating matter and directs the same to a circular conical groove *d*. Cocks *k* placed upon pipes *l* fixed into common bottom *g* of the spaces *e* allow the running off of the lubricating matter outside. The liquid ether produced by the condensation is taken back to the generator G by a feed pump N in order to vaporize and to commence again the cycle we have just described. Reservoirs O, P, Q, R, of glycerine or any other lubricating matter which will not combine with ether are connected with stuffing boxes *o, p, q, r*, to automatically lubricate the sliding rods of the latter and to retain at their passage the vapor of ether which might escape accidentally. The reservoirs O, P, Q, R, are connected by the conducting pipes *s, t, u, v*, provided with cocks *s', t', u', v'*, with a receiver S which is used to feed the reservoirs and to allow the retaining of the ether vapor which might escape, indicating to the engineer the stuffing box where they escape from by the means of a manometer T which can be put in connection with either of the reservoirs O, P, Q, R. by the cocks *s', t', u', v'*. The engineer can then tighten the stuffing box which is designated. After this, the ether vapor produced by accidentally escaping, gathered as it is in

the receiver S is sent to the condenser M to be condensed and to be led back to the generator in a liquid state by the pump N. The stuffing boxes *o, p, q, r*, are double; having an upper gland above the reservoir and a lower gland below the same each gland having packing and rundles or rings V on each side of the packing. Between the adjacent rings of the glands is a concentric, accordion shaped sleeve which is perforated and resilient to hold the rings elastically while permitting the free access of the lubricant.

I claim—

1. In combination in a vapor engine, the cylinder and piston, the stuffing boxes, the reservoirs for the lubricant communicating with the said stuffing boxes, the receiver for the escaping vapor, the pipe connections therefrom to the several boxes said pipes having suitable valves and the manometer on the receiver substantially as described.

2. In combination in a vapor engine, the cylinder and piston, the stuffing boxes for the piston, the oil reservoir in communication with the stuffing box, the receiver for the escaping vapor and the connection therefrom to the stuffing box, substantially as described.

In witness whereof I have hereunto set my hand in presence of two witnesses.

PAUL DE SUSINI.

Witnesses:

TH. DIJEON,
G. MAIRE.