

[54] **ELECTROSTATIC YARN BULKING APPARATUS**

[75] Inventors: **Mayer Mayer, Jr.**, New Orleans; **Albert Baril, Jr.**, Metairie, both of La.

[73] Assignee: **The United States of America as represented by the United States Department of Agriculture**, Washington, D.C.

[22] Filed: **Sept. 29, 1972**

[21] Appl. No.: **293,730**

**Related U.S. Application Data**

[62] Division of Ser. No. 129,735, March 31, 1971, Pat. No. 3,707,024.

[52] U.S. Cl. .... **28/1.2, 28/72.1, 28/75 WT**

[51] Int. Cl. .... **D02g 1/00, D02j 1/20, D06m 13/00**

[58] Field of Search ..... **28/1.2, 72.1, 75 WT; 117/93.4**

[56]

**References Cited**

**UNITED STATES PATENTS**

2,491,889	12/1949	Bennett et al. ....	117/93.4 R UX
3,046,632	7/1962	Tsutsumi.....	28/72.1 X
3,268,971	8/1966	Lockwood .....	28/72.1 X
3,646,744	3/1972	Rusca.....	28/72.1 UX
3,672,947	6/1972	Luscher et al.....	28/75 WT X

*Primary Examiner*—Louis K. Rimrodt  
*Attorney*—R. Hoffman

[57]

**ABSTRACT**

Chemical and physical methods and apparatuses have been employed to impart permanently bulked configuration to cellulosic and certain non-cellulosic yarns. This has been accomplished by passing the yarn through an electrostatic field either before or after impregnating the yarn with certain chemical crosslinking formulations.

**3 Claims, 3 Drawing Figures**

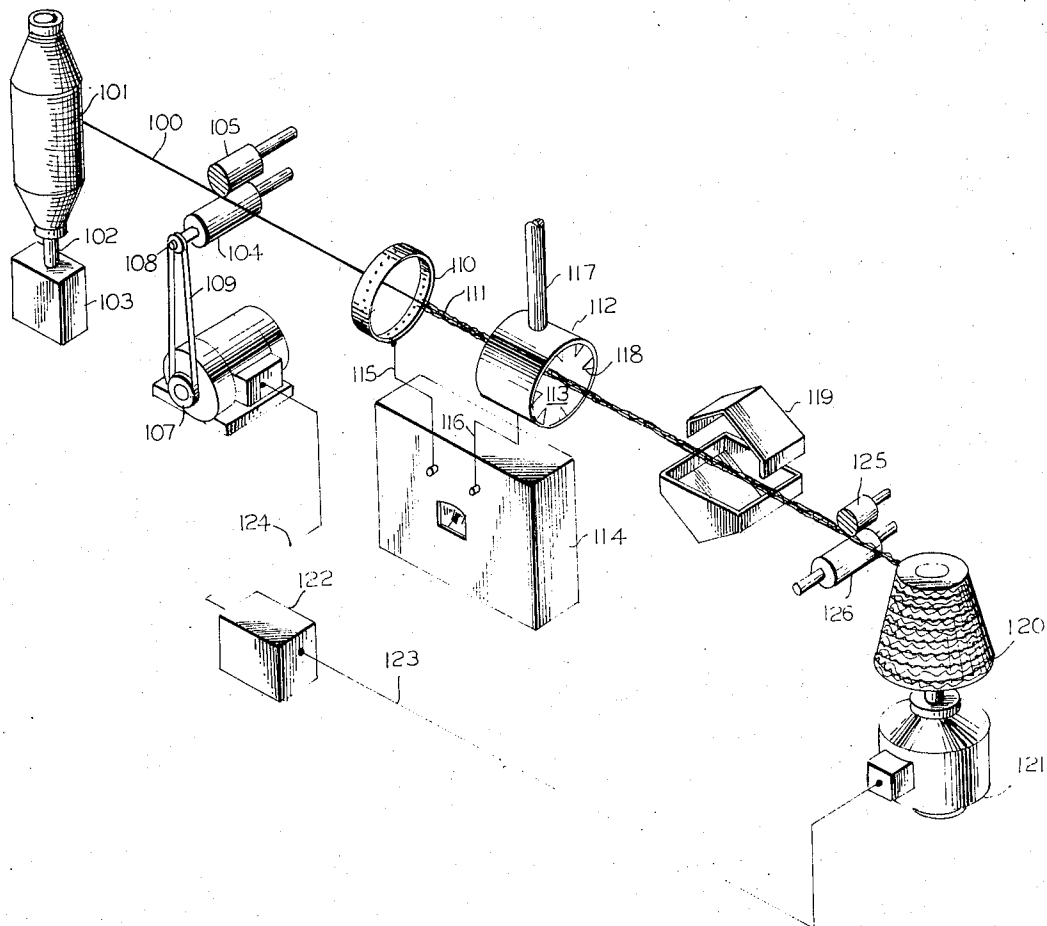

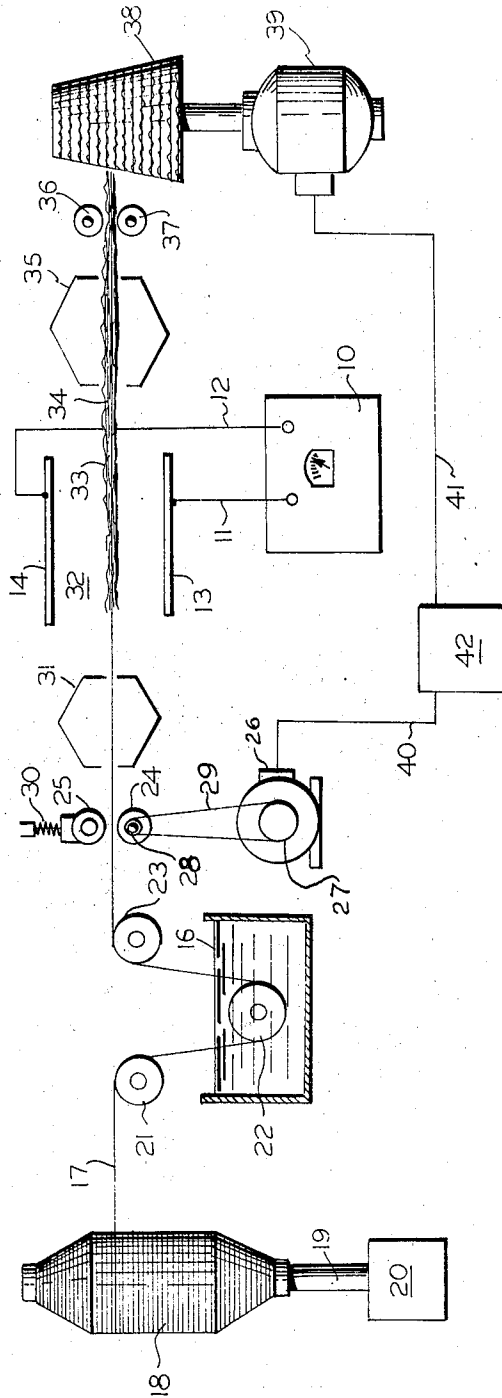

**FIG. 1**

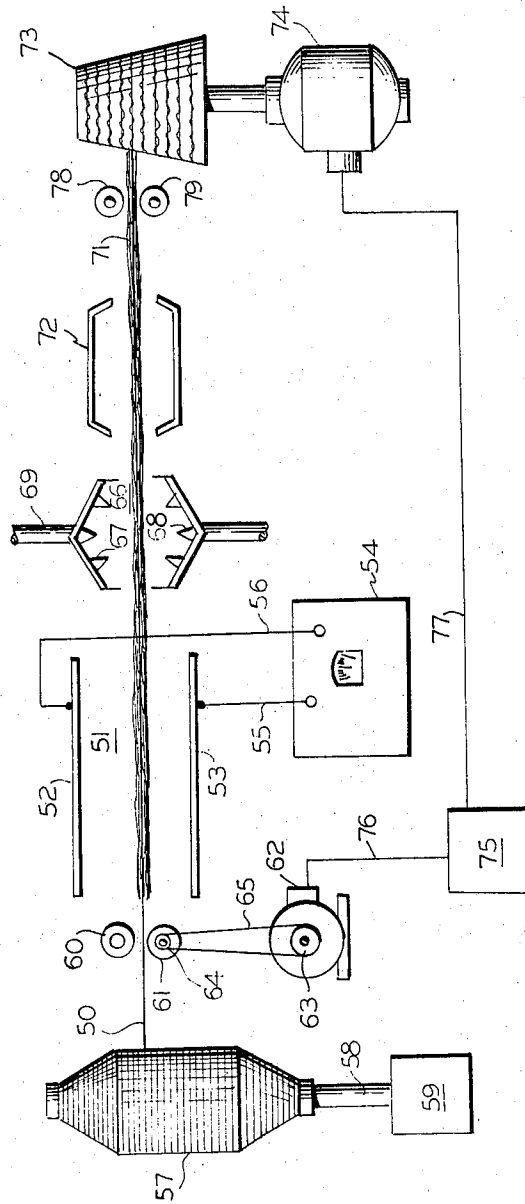
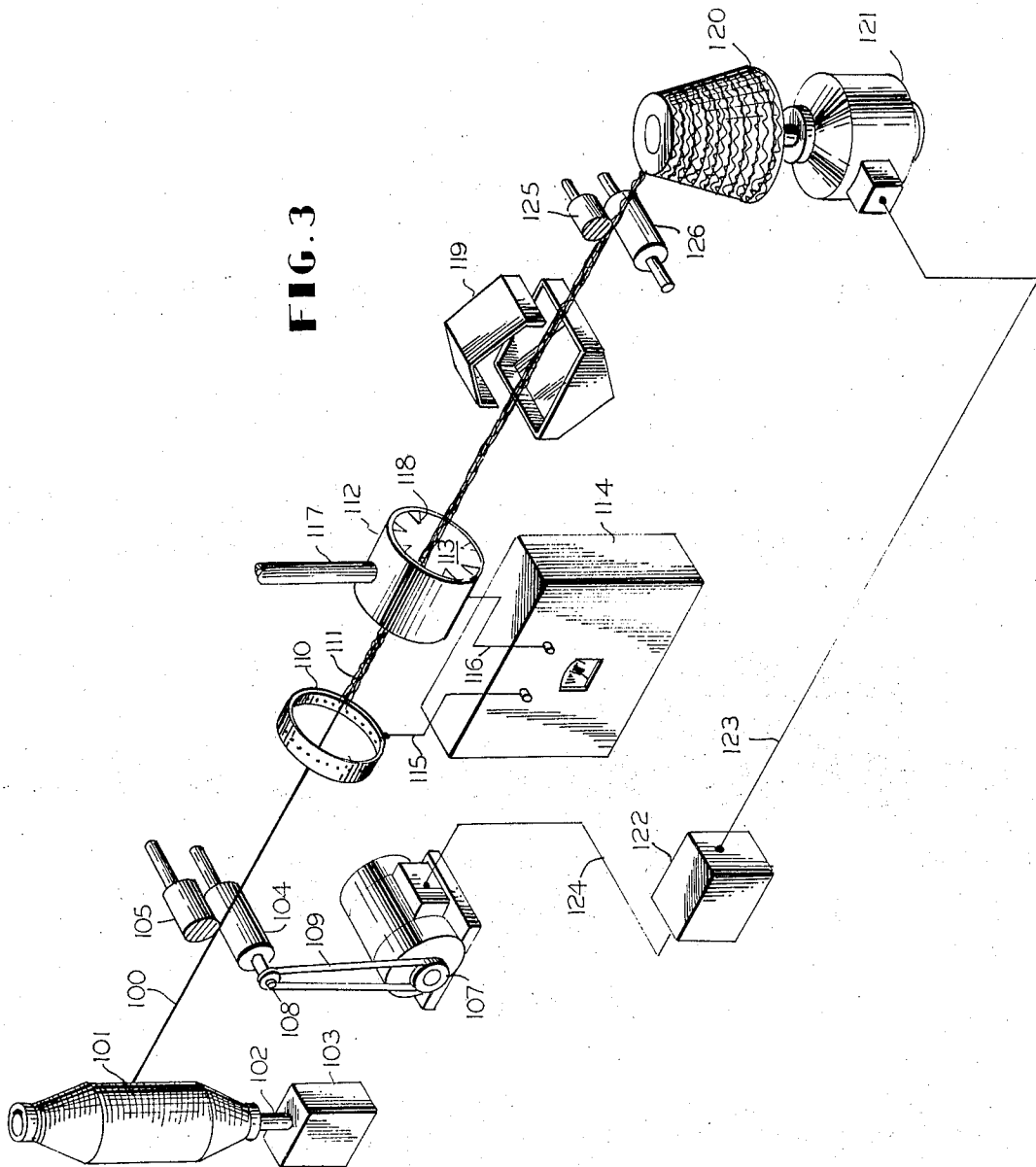

FIG. 2

FIG. 3



**ELECTROSTATIC YARN BULKING APPARATUS**

This application is a division of Ser. No. 129,735, filed Mar. 31, 1971, now U.S. Pat. No. 3,707,024, granted 12/26/72.

A non-exclusive, irrevocable, royalty-free license in the invention herein described, throughout the world for all purposes of the United States Government, with the power to grant sublicenses for such purposes, is hereby granted to the Government of the United States of America.

This invention relates to apparatuses and methods for bulking yarns. Specifically, this invention relates to the use of chemical and physical means to create and retain a bulked yarn. More specifically this invention relates to imparting to cellulosic and certain noncellulosic yarns a permanent bulked configuration by the application of an electrostatic field to a yarn treated with a crosslinking chemical formulation which can be permanently set.

It is well known to those skilled in the art of bulking or texturizing textile yarns that yarns produced from manmade staple fibers can be bulked by a variety of processes and apparatuses, and that yarns produced from natural fiber cannot be bulked successfully. Yarns made from cotton fibers particularly have not been responsive to conventional bulking methods of the prior art. Prior to the disclosure of the instant invention the general methods used for bulking yarns are (1) the application of air jets, (2) use of a stuffer box or similar crimping techniques, (3) drawing the yarn over a sharp edge, and (4) false-twisting. Following the bulking process the yarns are fixed in the bulked condition by the application of heat that causes plastic flow (in some fibers) and permanently sets the yarn. Efforts to produce bulked yarns of natural fibers by these methods have failed because natural fibers do not have the plastic flow or heat setting properties of manmade fibers.

The main object of the instant invention is to provide bulked textile yarns produced by a unique and novel method.

A second object of the instant invention is to provide the apparatus to use with the method for producing the new bulked yarns.

One method by which these objects have been accomplished is by utilizing an electric field to bulk a yarn which has been previously treated with a resin formulation which will set the bulked configuration permanently upon curing.

Another method by which these objects have been accomplished is by bulking a yarn upon passing through an electrostatic field, then treated with polymers, resins or any desirable crosslinking chemical formulation and subsequently cured. Depending upon the bulking effect desired, the treating and curing can be performed within the electrical field or outside the field.

A third method by which these objects are accomplished is to pass the yarn through a dielectric medium which possesses the properties of a crosslinking material so that simultaneously as the strand is being bulked by the electrostatic field it is picking up the "coating" which will later be cured to set the bulk. The dielectric medium could either be in the liquid or vapor phase.

A fourth method by which these objects are accomplished is to pass the yarn through an electric field thus causing the yarn to be bulked and the "bulk" fibers to be charged. Oppositely charged material such as a

crosslinking chemical is introduced and is attracted to the surface of the "bulk" fibers. This coating can be set and the bulking configuration retained.

While the inventions herein disclosed utilize descriptions applicable to yarns made from cotton fibers this should not be misconstrued to imply restriction to cotton yarns. The instant inventions can be used with cotton and other cellulosic yarns, with staple noncellulosic yarns, and it can also be used with blends (all non-conductive fibers).

To restate the description of the invention, one facet of the invention is the system consisting of a select combination of components comprising mainly a means of producing and maintaining an electrostatic field; namely, a power supply, defined electric field plates, a means for treating the yarn with suitable resins, a means for drying and curing the treated yarns, a yarn supply device, a yarn take-up device, and associated means for driving the component rotating parts.

Another facet of the invention is the method of using the apparatuses (of system) of the invention. The method generally consists of subjecting the yarns to an electrostatic field while the yarns are treated with a select crosslinking or polymer-forming formulation, then drying and curing the bulked, impregnated yarns to impart to these a permanent configuration.

Other objects and advantages of the invention will become apparent during the following discussion of the drawings:

FIG. 1 is a schematic elevation view of the apparatus for bulking yarns, showing the yarn input and output packages, electric field treating means, resin bath, drying and curing means and driving means. FIG. 2 is a schematic elevation view of an apparatus for bulking yarns, showing the yarn input and output packages, an electric field treating means, a means of applying the crosslinking chemical, a curing stage and a driving means. FIG. 3 is a pictorial view of another apparatus for bulking yarns, showing the yarn input and output packages, a corona ring discharge means, a means of applying the crosslinking chemical in charged droplets or charged spray, a curing means and a driving mechanism.

Referring now to the drawings, FIG. 1 is an embodiment showing a power supply 10 capable of, for example, 120 kv at 2 milliamps, connected by leads 11 and 12 to a set of electrodes 13 and 14. When the power supply is activated, an electrostatic field will be maintained between said electrodes 13 and 14. Electrodes 13 and 14 are essentially flat; however, they may be any shape to produce the desired electrostatic field. Tank 15 is a treating vessel containing a desired crosslinking reagent formulation 16, such as 5 to 20 percent dimethylol ethyleneurea (DMEU) or dimethylol dehydroxyethyleneurea (DMDHEU) and is maintained at a relative constant temperature and volume by conventional methods not shown. The cotton yarn 17 of supply package 18 on spindle 19 mounted to any type braking means such as friction clutch 20, is pulled over rotatably mounted guide roll 21 in bearing (not shown) and is held immersed in the solution by rotatably mounted roll 22 in bearings (not shown). The yarn proceeds over rotatable guide roll 23 in bearing (not shown), through squeeze rolls 24 and 25 in bearing (not shown), where excess solution is removed. Roll 24 is positively driven by any conventional variable speed drive means such as a variable speed motor 26 through

pulleys 27 and 28 and belt 29. Roll 24 is weighted by any method common to the art such as spring 30. The yarn 17 proceeds through any type drying stage common to the art such as radiant heater 31 prior to entering the electrostatic field 32. During passage of yarn 17 through the electrostatic field 32, the action of the field upon the fibers 33 of the yarn 17 causes said fibers 33 to be attracted away from axis of yarn 17 thus imparting bulk to the yarn. This bulking phenomenon can be achieved by a wide range of potential gradients of the electrostatic field, domain of the field and the variation of the field gap. The bulked yarn 34 then proceeds to any type curing stage such as radiant heater 35 wherein the resin-treated bulked yarn 34 is cured and set by any technique common to the art. This curing of the resin permanently sets the bulked yarn so that it can be knitted, woven, and otherwise handled without losing its bulked properties. The bulked yarn passes through rotatable mounted guide rolls 36 and 37 in bearings not shown and is wound on any type rotatable package such as cone 38. Cone 38 is driven by any means common to the art such as motor 39. Motors 39 and 27 are synchronously controlled by output of control 42 through leads 40 and 41. Other modifications of the apparatus of the invention will be obvious to those skilled in the art.

In addition to providing the chemical formulation for permanently fixing the bulked yarn, tank 15 can contain other chemicals to impart other desirable properties. For example, bath 16 can be formulated to contain DMEU for bulking, CMC for antisoiling, copper naphenate for mildew proofing, or tetrakis (hydroxy methyl) phosphonium chloride for flame resistance. Other possibilities for multipurpose treatment will be obvious to those skilled in the art of textile finishing.

FIG. 2 discloses an embodiment of the invention whereby a yarn is bulked by first passing the yarn 50 through an electrostatic field 51, produced by electrodes 52 and 53. The electrostatic field 51 is maintained by power supply 54 connected to electrodes 52 and 53 by leads 55 and 56. The yarn 50 from supply package 57 on spindle 58 mounted to any type braking system such as friction clutch 59 passes through rotatably mounted guide rolls 60 and 61 in bearing (not shown). Roll 61 is driven by any variable speed means common to the art such as variable speed motor 62, pulleys 63 and 64 and belt 65. Said yarn 50 passes through the electrostatic field 51 where it is bulked by the action of the said field as described in FIG. 1 and then proceeds to any type cross-linking resin treatment stage 66 wherein the chemical reagent can be applied to the yarn in the form of a vapor or liquid deposition technique by conventional means through conventional jets 67 and 68, supplied through input pipes 69 and 70 from a supply (not shown). The resin-treated bulked yarn then proceeds to any type curing means common to the art such as radiant heater 72 where the chemical reagent is cured and the bulked configuration is set. Bulked yarn 71 passes through rotatably mounted guide rolls 78 and 79 in bearings (not shown) where said bulked yarn 71 is wound on any type package such as cone 73. Cone 73 is driven by any conventional variable speed drive such as variable speed motor 74. Motors 63 and 74 are synchronously controlled by output of a conventional control 75 through leads 76 and 77.

As in the previous case the material used to set the bulk can be any crosslinking means such as DMEU or DMDHEU or a combination of DMEU or DMDHEU or a polymerizable reagent such as other chemical agents capable of providing other desirable properties such as antisoiling, rot resistance, flame proofing, and other treatments obvious to those skilled in the art of textile finishing.

It is understood that the method of treatment disclosed by FIG. 2 can be replaced by a method whereby the means of applying the chemical reagent to the bulked yarn and the means for curing the bulked yarn can be combined and placed within the configuration of the electrostatic field.

Another embodiment of our invention is disclosed in FIG. 3. In this embodiment yarn 100 from yarn supply package 101 on spindle 102 mounted on any type braking device such as friction clutch 103 is driven through rotatably mounted guide rolls 104 and 105 in bearings (not shown). Said guide roll 104 is driven by any conventional means such as variable speed motor 106, pulleys 107 and 108 and belt 109. Yarn 100 is fed through any type corona discharging means such as corona discharge ring 110. Said ring 110 causes the fiber within said yarn 100 to take on like charges. Since the fibers within yarn 100 will have like charges they will repel each other to produce a yarn with bulked configuration 111. The bulked yarn 111 will subsequently pass through any type deposition means such as deposition ring 112 where any suitable crosslinking resin such as 5 to 20 percent DMEU or DMDHEU is atomized in a charged form opposite to charge of bulked yarn so that charged particles 113 of resin will attach to the surface of the fibers of said bulked yarn 111. The corona discharge ring 110 and resin deposition ring 112 are connected to any conventional type power supply such as supply 114 through leads 115 and 116 to provide the fiber with a charge opposite to that of the resin particles. The crosslinking resin is fed to deposition ring 112 through inlet 117 from supply (not shown). Charged resin particles 113 are fed from any conventional type nozzle 118 in either liquid or gaseous form. The bulked resin-coated yarn 111 is fed through any type curing stage common to the art such as radiant heater 119 and thence passes rotatably mounted guide rolls 125 and 126 in bearings (not shown) to any conventional take-up package such as cone 120 driven by any type variable speed driving means such as variable speed motor 121. Motors 121 and 106 are synchronously controlled by any conventional means such as control 122 through leads 123 and 124. Other modifications of this apparatus will be obvious to those skilled in the art.

While all embodiments of this invention have been discussed in terms of yarn bulking, it is also understood that it is feasible to bulk a roving strand or fabric.

#### EXAMPLE 1

A solution of dimethylol dehydroxyethyleneurea (DMDHEU) of 9 percent and a 1 percent solution of zinc nitrate as a catalyst were contained in the tanks as shown in FIG. 1. A singles cotton yarn was immersed into this solution to totally saturate with the crosslinking resin solution. The resin impregnated yarn was passed through squeeze rolls to remove excess solution and then dried in an oven at 60°C for seven minutes. The DMDHEU and zinc nitrate treated yarn is passed through an electrostatic field of 30 kv per inch of air

gap. The potential gradient selected was in direct proportion to the degree of bulkiness desired, based on preliminary trials. Once the yarn was bulked it was passed through a curing stage where the bulked yarn was cured at 160°C for three minutes to cure the resin and set the bulked configuration of the yarn.

#### EXAMPLE 2

A solution of dimethyl ethyleneurea (DMEU) of 9 percent and a 1 percent solution of zinc nitrate as a catalyst and a solution of 28 percent solids of THPC amine were prepared and contained in the tank as shown in FIG. 1. A singles cotton yarn was immersed into this solution so that the yarn was totally saturated with the solution contained in the tank. The resin impregnated yarn was passed through squeeze rolls to remove excess solution and then dried in an oven at 60°C for 7 minutes. The dried yarn was passed through an electrostatic field of 30 kv per inch of air gap. The potential gradient selected was in direct proportion to the degree of bulkiness desired. Once the yarn was bulked it was passed through a curing stage where the bulked yarn was cured at about 160°C for 3 minutes to cure the resin and set the bulked configuration of the yarn and render it flame resistant.

The solution can contain other chemicals to impart desirable properties such as antisoiling chemicals or mildew proofing.

#### EXAMPLE 3

A singles cotton yarn was bulked by first passing the yarn through an electrostatic field. A singles cotton yarn was passed through the field and bulked, then transported to a treatment stage wherein 16 percent solution of vinylidene chloride, acrylonitrile copolymer in methyl ethyl ketone was applied to the surface of the bulked yarn in order to maintain the bulked configuration. The resin coated bulked yarn was then passed through a drying stage (as in Example 2) where the resin coating was dried and the bulked configuration set. The spray can be formulated to contain flameproofing, mildew proofing or antisoiling compounds so that these properties are imparted to the yarn at the same time that the bulked configuration is set.

#### EXAMPLE 4

A singles cotton yarn was passed through a corona discharge ring, as shown in FIG. 3. At this stage the fibers of the yarn received a charged (sign of charge depended on how the discharge ring was connected to the power supply) and repelled each other so that a bulked configuration was produced. The charged yarn was then passed through a resin deposition stage wherein a crosslinking resin is applied. The solution of resin was atomized and charged (10-30 kv) so as to be of opposite charge to that of the fiber surface. The charged droplets were attracted to the surface of the charged fibers. The electrostatic coated bulked yarn was then passed through a curing stage for about three minutes at 160°C where the resin was set to fix the bulked configuration of the yarn. The solution used was a 9 percent solution of DMDHEU with a 1 percent solution of zinc nitrate catalyst. The solution can be a combination of the cited chemicals and may contain other

chemicals capable of imparting certain properties such as flameproofing, antisoiling, or mildew proofing to the bulked yarn.

We claim:

1. A system for imparting to staple yarns on non-conducting fibers a permanent bulked configuration, the system comprising the harmonious combination of these components to function as a unit:

- a. means for feeding strands of natural and/or synthetic staple yarns to and from an electrostatic field and a chemical treating system,
- b. an electrostatic field, established by a functioning associated power supply in the domain between electrodes, said electrostatic field being of an intensity suitable for imparting a bulked configuration to staple yarns as said yarns traverse the domain of the electrostatic field,
- c. power means for providing and maintaining the power requirements of the corona discharge ring,
- d. chemical reagent dispensing apparatus capable of impregnating the yarns with chemical reagents,
- e. apparatus for drying the bulked then impregnated yarns,
- f. apparatus for curing the bulked and wet impregnated yarns, and
- g. associated means for driving the component rotating parts which control the feed, take-up, travel and tension of yarns; for regulating the temperatures, voltages, and motion of the various components of the system; and for chemical dispensing device.

2. The system of claim 1 wherein the apparatus of step (b) would be placed after the apparatus of (d) so as to impregnate the yarns firstly and bulk then secondly.

3. A system for imparting to staple yarns on non-conducting fibers a permanent bulked configuration, the system comprising the harmonious combination of these components to function as a unit:

- a. means for feeding strands of natural and/or synthetic staple yarns to and from a corona discharge ring and a chemical treating system,
- b. a corona discharge ring through the center of which a plurality of yarns will pass when the system is energized, the discharge being of an intensity suitable for imparting stapled yarns a bulked configuration as the said yarns traverse the domain of the electrostatic field,
- c. power means for providing and maintaining the power requirements of the corona discharge ring,
- d. chemical dispensing apparatus capable of impregnating yarn strands with chemical reagent formulations,
- e. apparatus for drying the bulked then impregnated yarns,
- f. apparatus for curing the bulked and wet impregnated yarns, and
- g. associated means for driving the component rotating parts which control the feed, take-up, travel and tension of yarns; for regulating the temperatures, voltages, and motion of the various components of the system; and for chemical dispensing device.

\* \* \* \* \*