



INTERNATIONAL APPLICATION PUBLISHED UNDER THE PATENT COOPERATION TREATY (PCT)

(51) International Patent Classification ⁵ :

H02G 3/06, H01B 17/58

A1

(11) International Publication Number:

WO 91/11839

(43) International Publication Date:

8 August 1991 (08.08.91)

(21) International Application Number: PCT/GB91/00121

(22) International Filing Date: 29 January 1991 (29.01.91)

(30) Priority data:
9002021.5 30 January 1990 (30.01.90) GB

(71) Applicant (for all designated States except US): GRAU LIMITED [GB/GB]; Arrowdale Road, Redditch, Worcestershire B98 7EZ (GB).

(72) Inventor; and

(75) Inventor/Applicant (for US only): BROOME, William, Sidney [GB/GB]; Brackendale, 53 Pepper Street, Inkberrow, Worcestershire WR7 4EJ (GB).

(74) Agent: FORRESTER, KETLEY & CO.; Chamberlain House, Paradise Place, Birmingham B3 3HP (GB).

(81) Designated States: AT (European patent), BE (European patent), BR, CH (European patent), DE (European patent), DK (European patent), ES (European patent), FR (European patent), GB, GB (European patent), GR (European patent), IT (European patent), JP, LU (European patent), NL (European patent), SE (European patent), SU, US.

Published

With international search report.

(54) Title: BUSHING

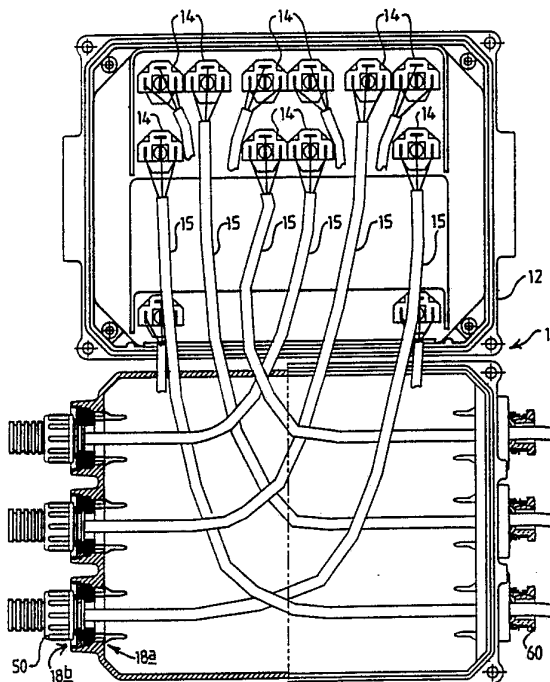

(57) Abstract

A bushing comprising a tubular body having a central passage to receive an elongate element, a gland to provide a seal between the elongate element and the bushing and, at one end of the body, means adapted to interengage with an opening in a fitting to attach the bushing to the fitting.

FOR THE PURPOSES OF INFORMATION ONLY

Codes used to identify States party to the PCT on the front pages of pamphlets publishing international applications under the PCT.

AT	Austria	ES	Spain	MG	Madagascar
AU	Australia	FI	Finland	ML	Mali
BB	Barbados	FR	France	MN	Mongolia
BE	Belgium	GA	Gabon	MR	Mauritania
BF	Burkina Faso	GB	United Kingdom	MW	Malawi
BG	Bulgaria	GN	Guinea	NL	Netherlands
BJ	Benin	GR	Greece	NO	Norway
BR	Brazil	HU	Hungary	PL	Poland
CA	Canada	IT	Italy	RO	Romania
CF	Central African Republic	JP	Japan	SD	Sudan
CG	Congo	KP	Democratic People's Republic of Korea	SE	Sweden
CH	Switzerland	KR	Republic of Korea	SN	Senegal
CI	Côte d'Ivoire	LI	Liechtenstein	SU	Soviet Union
CM	Cameroon	LK	Sri Lanka	TD	Chad
CS	Czechoslovakia	LU	Luxembourg	TG	Togo
DE	Germany	MC	Monaco	US	United States of America
DK	Denmark				

Title: "Bushing"

This invention relates to a bushing for interposition between an elongate element, such as an electrical conductor or a conduit therefor, and an opening in a fitting, such as a junction box.

Hitherto such a bushing has comprised a tubular body having a central passage to receive an elongate element and a gland to provide a seal between the element and the bushing and, at one end of the body, an externally screw threaded spigot adapted to be threadedly received in a screw threaded opening provided in the fitting.

An object of the present invention is to provide a new and improved bushing.

According to one aspect of the invention we provide a bushing comprising a tubular body having a central passage to receive an elongate element, a gland to provide a seal between the elongate element and the bushing and, at one end of the body, means adapted to inter-engage with an opening in a fitting to attach the bushing to the fitting.

Said means may comprise a plurality of tongues which project from said one end of the body generally parallel to a central longitudinal axis of said passage and which are adapted to inter-engage with said opening.

Each tongue may be provided with an abutment surface which extends generally transversely relative to said axis to engage a co-operating retaining part of the fitting.

Each tongue may be resiliently deformable inwardly towards said axis to enable passage of said abutment surface into said opening from a first end towards a second end and subsequently to move outwardly away from said axis for attaching relationship with said retaining part.

The abutment surfaces may face towards said first end of the opening and the retaining parts may face away from said first end of the opening.

Preferably each tongue has an inclined surface which extends from a position adjacent the radially outermost part of said abutment surface in a direction which is inclined inwardly and towards the free end of the tongue.

Preferably each tongue has a manually engageable extension which projects beyond said abutment surface to permit of manipulation of the tongues radially inwardly to permit of displacement of said abutment surface out of radial alignment with said retaining part to permit of removal of the bushing.

The body may be provided with an abutment for engagement by a resilient member which is adapted to engage with an abutment of the opening so as normally to bias the body in a direction to urge said abutment surface and retaining part into engagement.

The body may be provided with a portion which extends into said opening between said tongues and which is of such configuration so as to prevent engagement between said elongate element and said opening.

Preferably a pair of diametrically opposite tongues are provided.

The body may be screw threaded to receive a nut member and said gland being movable into sealing engagement with the elongate element by tightening of the nut member relative to the body.

The bushing may be screw threaded at the opposite end thereof to said means.

According to another aspect of the invention we provide a junction box having at least one opening therein in which a bushing according to the first aspect of the invention is engaged.

A seal member may be provided in sealing engagement between the bushing and the opening.

The resilient member may provide said seal member.

Preferably the junction box has a lid which carries a plurality of first electrical connectors and said elongate elements comprising electrical conductors each of which is provided with a second connector to mate with the first connectors provided on the lid.

The first connectors provided on the lid may be electrically connected to electrical components mounted on the lid.

An embodiment of the invention will now be described by way of example with reference to the accompanying drawings wherein:

FIGURE 1 is a plan view of a junction box embodying the invention shown in an open condition and partly in section,

FIGURE 2 is a longitudinal partial cross-section through the box of Figure 1 but with the lid in a closed condition.

FIGURE 3 is an end elevation of the body of the bushing of Figures 1 and 2,

FIGURE 4 is a section on the line 4-4 of Figure 3 but showing the body in position in an opening of the box of Figures 1 and 2,

FIGURE 5 is a section on the line 5-5 of Figure 3, and

FIGURE 6 is a section on the line 6-6 of Figure 4.

Referring to the drawings, a junction box is indicated clearly at 10 and comprises a base part 11 which may be, and in this example is, pivotally connected in conventional manner to a lid 12. The lid 12 carries a plurality of electrical components of any desired type for the application concerned and the electrical components are provided with a plurality of first connectors 13 of conventional type. A plurality of second connectors 14 are engaged therewith and are connected to the ends of electrical conductors 15 which pass through openings 16 in a side wall 17 of the base part 11 of the junction box 10. In the illustrated example the box has twelve openings, arranged in two rows of three openings on each of two opposite sides of the box, and twelve first connectors 13. However, for clarity only the top rows and associated conductors are shown in Figure 1 and some second connectors and associated conductors have been omitted from Figure 2.

The openings 16 are in the form of generally cylindrical bosses 18 which project inwardly from the wall 17 into the interior of the junction box and each port 19 thus provided is identical.

Received within each port is a bushing 20. Each bushing 20 comprises a body 21 best shown in Figures 3 to 6 and the bodies are essentially similar except that they may be provided either with an external screw thread as shown at 22 on the left-hand side of Figure 2, or an internal thread as shown at 23 on the right-hand side of Figure 1.

The body shown in Figures 3 to 6 has an external screw thread as shown at 22 and the body 21 is generally cylindrical having a stepped axially extending passage 24 therethrough and a reduced diameter part 25 which is provided with the external screw thread 22. The body 21 has a circumferentially extending groove 26 of generally square configuration provided therein to receive an O-ring seal 27 adapted to engage a shoulder 28 of the port 19.

A pair of diametrically opposite tongues 30 project from an end surface 31 of the body via a reduced cross-section neck part 30a and tongues 30 each have a radially outwardly extending abutment surface 32 for engagement with a retaining part comprising a surface 35 provided by an inner end surface 18a of the boss 18, whilst an inclined surface 33 extends inwardly and towards the free end 34 of the tongues 30 from a position adjacent the radially outer end of the surfaces 32. Between the radially inner end of the surfaces 33 and the free end 34 of the tongues is a manually engageable portion 36 which can be gripped between, for example, the thumb and first finger of a user to enable the tongues to be deformed inwardly towards each other to enable the abutment surfaces 32 to be moved radially inwardly so as to be radially out of alignment with the retaining surfaces 35.

Between the tongues 30 are a pair of diametrically opposite guard portions 40 which are adapted to extend through the port so as to be disposed between the conductors 15 and the wall of the port and so as to prevent engagement therebetween. If desired the guard portions may be omitted.

If desired more than two such tongues may be provided. Preferably guard portions are provided between the tongues.

In the externally screw threaded version as shown in Figures 4 to 6 and at 22 in Figure 2, an internally threaded nut member 50 is engaged with the screw thread 22 and has an inwardly directed flange 51 by which a resiliently deformable gland 52 is clamped between the flange 51 and the end surface 53 of the body 21 and thus deformed radially into sealing engagement between the nut member 50 and a conduit 54 surrounding the electrical connector.

In the alternative configuration shown at 23 where the body is internally screw threaded, an externally threaded nut member 60 is provided which can act on a member 61 to urge a gland 62 against a shoulder 63 provided between the larger and smaller diameter parts of the internal passage 24 of the body 21 and thus cause the gland to be deformed into sealing engagement with the body, nut and conductor.

In use, it is preferred that an electrical conductor or associated conduit is brought into sealing relationship with the bushing, by tightening of the nut member 50 or 60, prior to assembly. For example, the bushings may be thus assembled to the conductors during manufacture and the connectors 14 are fastened to the conductors so that an appropriate length of conductor is left between the bushing and the connector.

On site, a connector 14 is passed through a desired port 19, the port being of appropriate size to permit such passage and then the connector can be manually engaged with an associated connector 13 on the lid. The bushing is then inserted into the port from a first end 18_b thereof externally of the box 10 towards a second inner end 18_a thereof internally of the box. The tongues 30 are displaced as a result of their inherent resilience inwardly towards each other as a result of engagement of the inclined surfaces 33 with the internal surface of the port 19 so as to permit the outer end of the abutment surface 32 to pass through the port into axial alignment with the retaining surfaces 35 whereupon the tongues can snap outwardly as a result of their inherent resilience into attracting relationship with the retaining surfaces 35.

The O-ring seal 27 and the associated surfaces of the groove 26 and shoulder 28 are dimensioned so that the O-ring is compressed when the abutment and retaining surfaces 32, 35 are in attaching relationship so that the O-ring 27 serves normally to provide a resilient bias to maintain the abutment and retaining surfaces 32, 35 in engagement and thus provide a secure attachment without free movement between the port and bushing. The O-ring 27 also acts as a seal between the part 19 and the bushing 20.

The seal may be provided by engagement between the outside diameter of the O-ring 27 and the wall of the part 19 and/or the shoulder 28 and the inside diameter of the O-ring and the base and/or a side wall or the side walls of the groove 26.

Because the attachment of the bushing to the junction box is achieved without requiring any rotation of the cable, the above described pre-assembly of the bushing to the cable may be provided.

Because the tongues are disposed within the junction box and can only be displaced inwardly towards each other by manual engagement of the part, 36 thereof, it is not possible to remove the bushing from externally of the junction box, thereby providing a "tamper-proof" facility.

Because the tongues are disposed within the fitting, i.e. junction box, they are protected from the element and from ultra-violet light and therefore degradation of the plastics material of which the body is made, which is, for example, nylon 6, is avoided. It should, however, be appreciated that the bushing may be made of any suitable material which provides a desired degree of inherent resilience to the tongues.

It should also be appreciated that the port of the fitting does not require machining to provide a screw thread and sufficient accuracy in the shape of the port can be achieved as a result of moulding of the junction box by a suitable manufacturing technique (for example pressure die casting using aluminium alloy), thereby avoiding the need to perform any machining operation on the ports.

Preferably the fitting and the port are provided with inter-engaging means to permit the bushing to be received in the port in only a single orientation, for example with the tongues horizontal so as to present the tongues in a most convenient orientation for a user to be able to manually move them towards each other for removal of the bushing. The above described means may comprise a radially outwardly projecting lug on the body 21 receivable in a corresponding recess in the housing.

By providing the projections 40 engagement between a cable or conduit and the port is avoided, thereby avoiding any risk of damage to the cable and, since the bushing is made of a material which is electrically insulating, should damage to a cable occur where it contacts the bushing, electrical insulation from the body of the junction box is provided.

Bushings as described hereinbefore are made in a desired range of sizes to fit a desired range of cable diameter and conduit diameter and appropriate glands are provided. In the example illustrated, two types of gland have been described but if desired any other form of gland may be provided by forming the body 21 appropriately to receive the gland and its tightening assembly, although, of course, the remainder of the body including the tongues remains as described above. Of course, the different types of bushings may be distributed as desired between the ports of the junction box. Bushings embodying the present invention may be used with ports of any desired fitting.

If desired the bushing may be used in a conventional manner by appropriate tightening or untightening of the nut member 50, 60 with the bushing remaining attached to the fitting.

The features disclosed in the foregoing description, or the following claims, or the accompanying drawings, expressed in their specific forms or in terms of a means for performing the disclosed function, or a method or process for attaining the disclosed result, or a class or group of substances or compositions, as appropriate, may, separately or in any combination of such features, be utilised for realising the invention in diverse forms thereof.

CLAIMS:

1. A bushing comprising a tubular body having a central passage to receive an elongate element, a gland to provide a seal between the elongate element and the bushing and, at one end of the body, means adapted to inter-engage with an opening in a fitting to attach the bushing to the fitting.
2. A bushing according to Claim 1 wherein said means comprises a plurality of tongues which project from said one end of the body generally parallel to a central longitudinal axis of said passage and which are adapted to inter-engage with said opening.
3. A bushing according to Claim 2 wherein each tongue is provided with an abutment surface which extends generally transversely relative to said axis to engage a co-operating retaining part of the fitting.
4. A bushing according to Claim 3 wherein each tongue is resiliently deformable inwardly towards said axis to enable passage of said abutment surface into said opening from a first end towards a second end and subsequently to move outwardly away from said axis for attaching relationship with said retaining part.
5. A bushing according to Claim 4 wherein the abutment surfaces face towards said first end of the opening and the retaining parts face away from said first end of the opening.
6. A bushing according to Claim 5 wherein each tongue has an inclined surface which extends from a position adjacent the radially outermost part of said abutment surface in a direction which is inclined inwardly and towards the free end of the tongue.

7. A bushing according to any one of Claims 3 to 6 wherein each tongue has a manually engageable extension which projects beyond said abutment surface to permit of manipulation of the tongues radially inwardly to permit of displacement of said abutment surface out of radial alignment with said retaining part to permit of removal of the bushing.
8. A bushing according to any one of Claims 3 to 7 wherein the body is provided with an abutment for engagement by a resilient member which is adapted to engage with an abutment of the opening so as normally to bias the body in a direction to urge said abutment surface and retaining part into engagement.
9. A bushing according to any one of Claims 2 to 8 wherein the body is provided with a portion which extends into said opening between said tongues and which is of such configuration so as to prevent engagement between said elongate element and said opening.
10. A bushing according to any one of Claims 2 to 9 wherein a pair of diametrically opposite tongues are provided.
11. A bushing according to any one of the preceding claims wherein the body is screw threaded to receive a nut member and said gland is movable into sealing engagement with the elongate element by tightening of the nut member relative to the body.
12. A bushing according to Claim 11 wherein the bushing is screw threaded at the opposite end thereof to said means.
13. A bushing substantially as hereinbefore described with reference to the accompanying drawings.

14. A junction box having at least one opening therein in which a bushing according to any one of Claims 1 to 13 is engaged.
15. A junction box according to Claim 14 having a seal member in sealing engagement between the bushing and the opening.
16. A junction box according to Claim 15 when dependent on Claim 8 or any one of Claims 9 to 12 when dependent on Claim 8 wherein the resilient member provides said seal member.
17. A junction box according to any one of Claims 14 to 16 wherein the junction box has a lid which carries a plurality of first electrical connectors and said elongate elements comprising electrical conductors each of which is provided with a second connector to mate with the first connectors provided on the lid.
18. A junction box according to Claim 17 wherein the first connectors provided on the lid are electrically connected to electrical components mounted on the lid.
19. A junction box substantially as hereinbefore described with reference to the accompanying drawings.
20. Any novel feature or novel combination of features described herein and/or in the accompanying drawings.

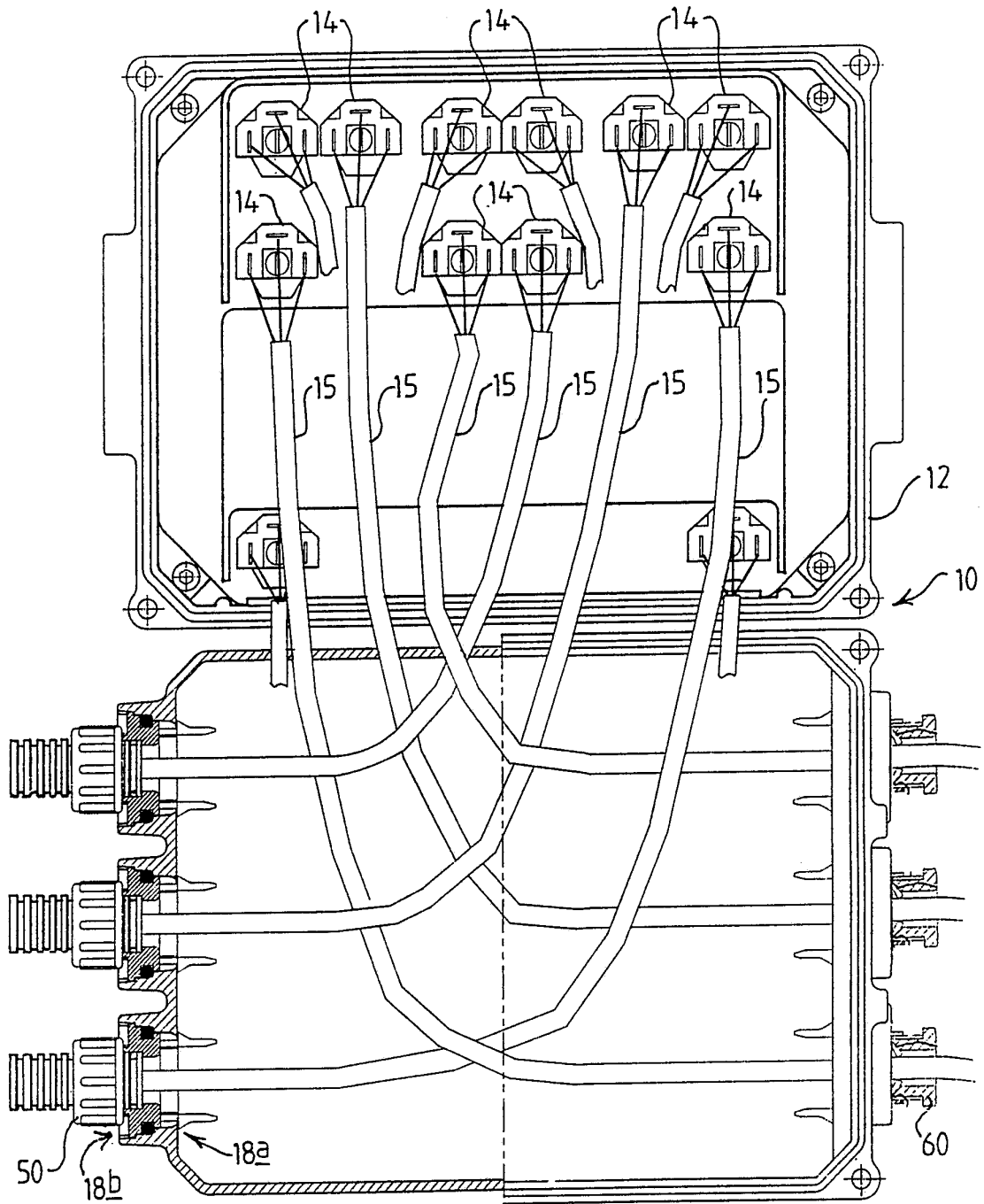

FIG 1

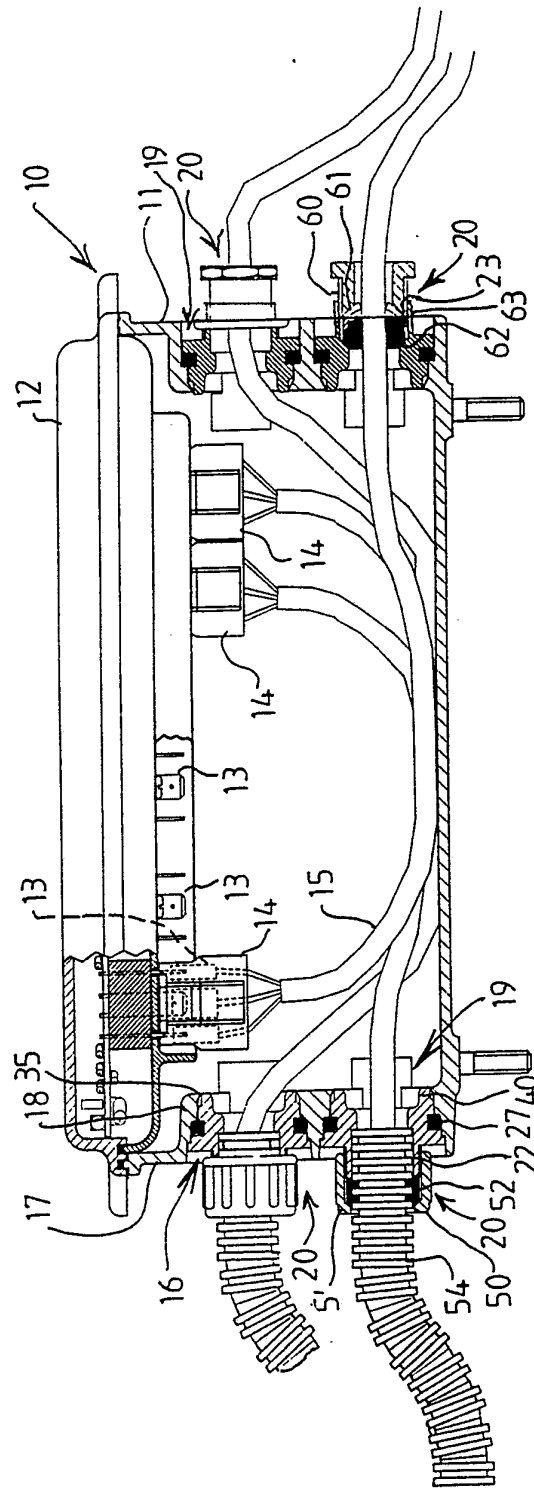

FIG 2

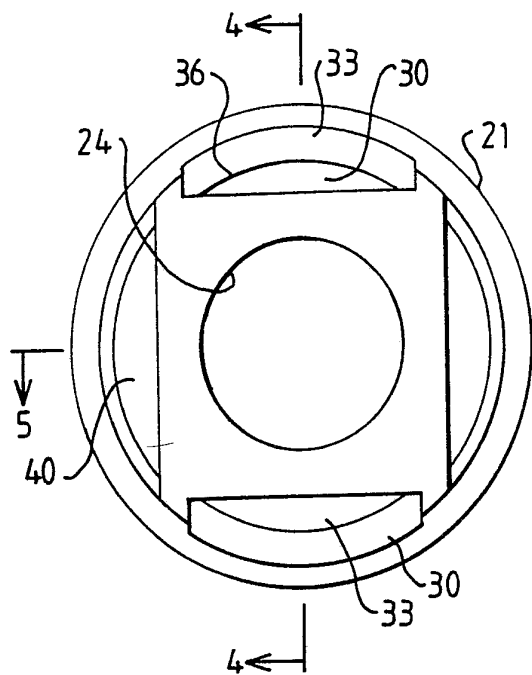

FIG 3

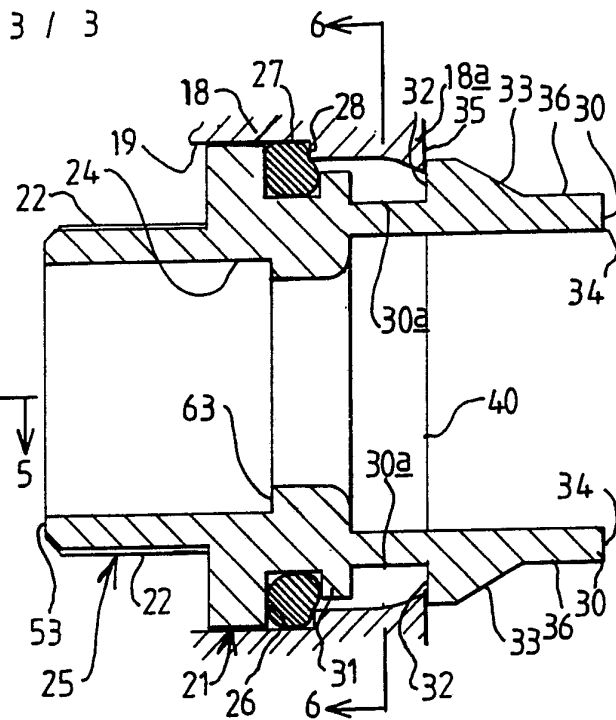

FIG 4

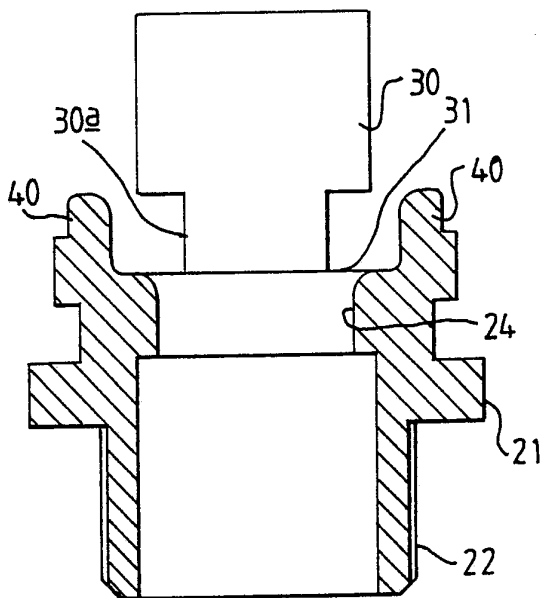

FIG 5

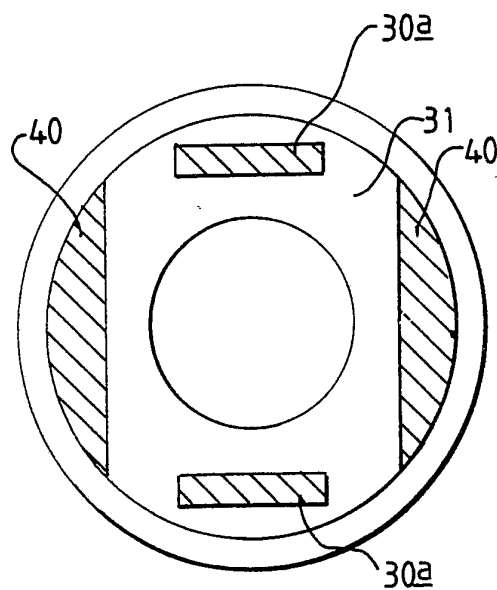

FIG 6

INTERNATIONAL SEARCH REPORT

PCT/GB 91/00121

International Application No

I. CLASSIFICATION OF SUBJECT MATTER (if several classification symbols apply, indicate all) ⁶		
According to International Patent Classification (IPC) or to both National Classification and IPC Int.Cl. 5 H02G3/06 ; H01B17/58		
II. FIELDS SEARCHED		
Minimum Documentation Searched ⁷		
Classification System	Classification Symbols	
Int.Cl. 5	H02G ; H01B	
Documentation Searched other than Minimum Documentation to the Extent that such Documents are Included in the Fields Searched ⁸		
(Empty space for additional search details)		
III. DOCUMENTS CONSIDERED TO BE RELEVANT⁹		
Category ^o	Citation of Document, ¹¹ with indication, where appropriate, of the relevant passages ¹²	Relevant to Claim No. ¹³
X	EP,A,106001 (GEBRUDER SULZER) 25 April 1984 see the whole document ---	1-6, 8, 10, 14-20
X	US,A,3285551 (A.E. TSCHANZ) 15 November 1966 see the whole document ---	1-8, 10, 14-16 11-13
A	(Empty space)	(Empty space)
<p>^o Special categories of cited documents : ¹⁰</p> <p>"A" document defining the general state of the art which is not considered to be of particular relevance</p> <p>"E" earlier document but published on or after the international filing date</p> <p>"L" document which may throw doubts on priority claim(s) or which is cited to establish the publication date of another citation or other special reason (as specified)</p> <p>"O" document referring to an oral disclosure, use, exhibition or other means</p> <p>"P" document published prior to the international filing date but later than the priority date claimed</p> <p>"T" later document published after the international filing date or priority date and not in conflict with the application but cited to understand the principle or theory underlying the invention</p> <p>"X" document of particular relevance; the claimed invention cannot be considered novel or cannot be considered to involve an inventive step</p> <p>"Y" document of particular relevance; the claimed invention cannot be considered to involve an inventive step when the document is combined with one or more other such documents, such combination being obvious to a person skilled in the art.</p> <p>"&" document member of the same patent family</p>		
IV. CERTIFICATION		
Date of the Actual Completion of the International Search 22 APRIL 1991	Date of Mailing of this International Search Report 24. 05. 91	
International Searching Authority EUROPEAN PATENT OFFICE	Signature of Authorized Officer RIEUTORT A.S.	

ANNEX TO THE INTERNATIONAL SEARCH REPORT
ON INTERNATIONAL PATENT APPLICATION NO.

PCT/GB 91/00121
SA 43986

This annex lists the patent family members relating to the patent documents cited in the above-mentioned international search report.
The members are as contained in the European Patent Office EDP file on
The European Patent Office is in no way liable for these particulars which are merely given for the purpose of information. 22/04/91

Patent document cited in search report	Publication date	Patent family member(s)	Publication date
EP-A-106001	25-04-84	None	
US-A-3285551		None	

EPO FORM P0479

For more details about this annex : see Official Journal of the European Patent Office, No. 12/82