

Aug. 25, 1959

G. C. KOHL
SELF-RETRACTING NOZZLE UNIT FOR SUBSURFACE
WATER SPRINKLER SYSTEMS
Filed Dec. 23, 1957

2,901,183

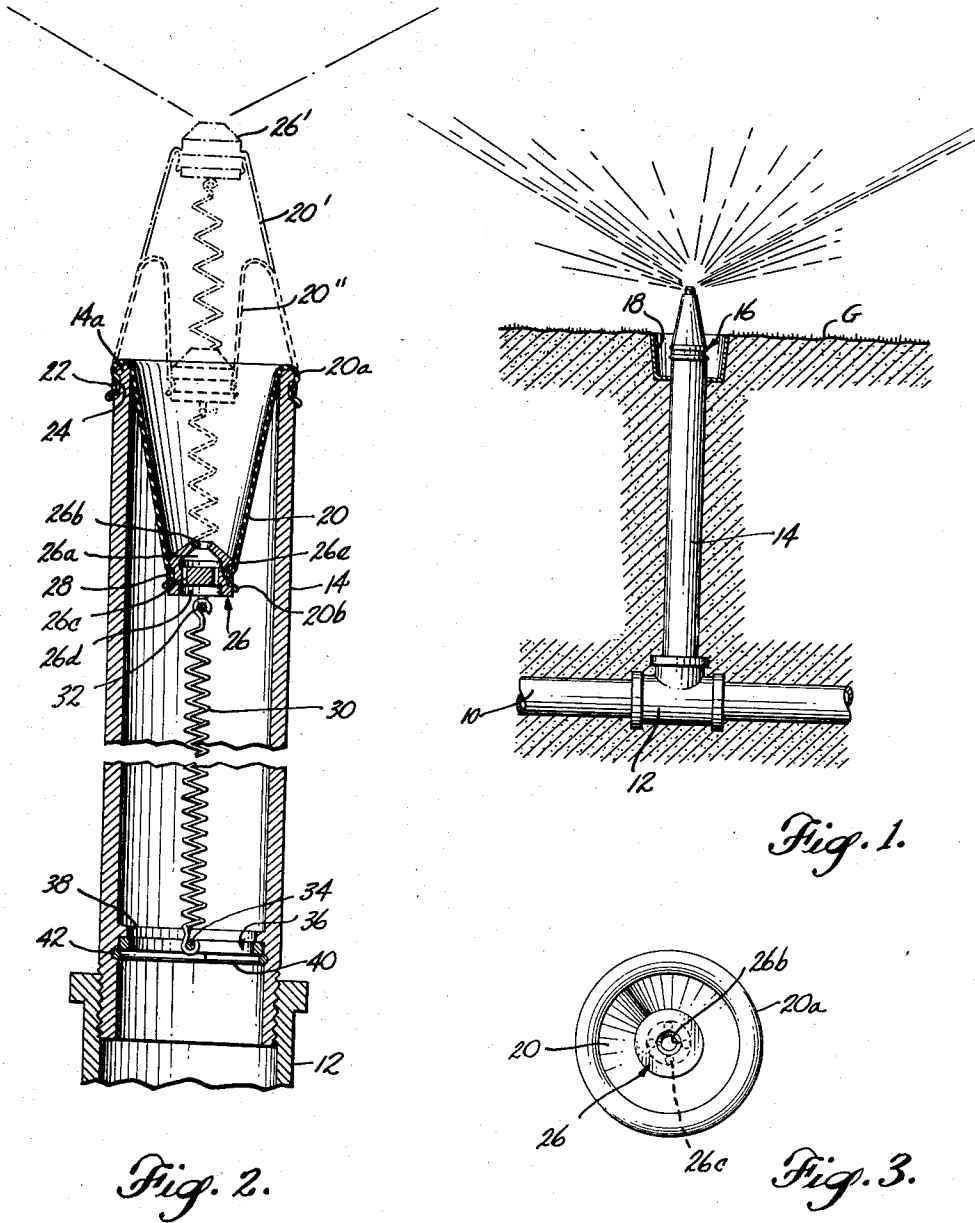

Fig. 2.

Fig. 1.

Fig. 3.

INVENTOR.
GERALD C. KOHL

BY
Reynolds, Beach & Christensen
ATTORNEYS

1

2,901,183

SELF-RETRACTING NOZZLE UNIT FOR SUBSURFACE WATER SPRINKLER SYSTEMS

Gerald C. Kohl, Tacoma, Wash.

Application December 23, 1957, Serial No. 704,675

3 Claims. (Cl. 239—205)

This invention relates to an improvement in lawn sprinkler systems and the like of the subsurface or permanently installed type, and more particularly concerns a self-retracting nozzle unit for use therein. The invention herein illustratively described by reference to the presently preferred embodiment thereof; however, it will be recognized that certain modifications and changes therein with respect to details may be made without departing from the underlying essentials involved.

Efficient broadcast of water for lawn sprinkling requires a nozzle to be placed above ground level. Yet, in a permanent type lawn sprinkler system with underground distribution pipes feeding spaced nozzle risers the nozzles are usually recessed in order to minimize danger of injury to persons and damage to mowing equipment. This requires cupping or cratering the sod around the nozzle so as to clear the discharge and is in itself a minor hazard. The typical installation is therefore a compromise. Moreover, subsequent ground settlement even around a properly installed nozzle creates special maintenance problems in order to maintain sufficient but not excessive recessing of the nozzle.

For the foregoing and related reasons retracting nozzles of various forms have been proposed heretofore. These usually were of the telescoping or sliding type raised by water pressure and returned by gravity or the recoil of a spring. Never fully practical because of parts sticking and binding from corrosion and infiltration of dirt, lawn clippings, etc., such devices have not enjoyed extensive use. Yet their basic objective has remained important and valid.

Any retractable nozzle suitable for sprinkler systems of the type mentioned must be adapted to operate satisfactorily and consistently under the widely different and variable water pressures often encountered in domestic and municipal systems. It must not bind with rust and corrosion nor with mineral deposits from the water. Infiltration of dirt, lawn clippings and other debris should be prevented as largely as possible so as to avoid clogging of the nozzle orifice and must not interfere with proper retraction of the nozzle. Preferably the device should be readily assembled and disassembled for inspection, cleaning and repairs, if necessary.

These objectives, together with the more general attributes of low cost, durability, reliability and efficiency comprise important objects of the present invention.

Another object is a retracting nozzle unit for purposes indicated wherein the nozzle parts in retracted position are protectively housed within the supporting pipe. A further object is such a retracting nozzle unit wherein protraction of the nozzle head is effected by water pressure and, because of the construction and mode of operation of the unit, the nozzle head is always protracted to a definite operative position unaltered by even wide variations or differences in water supply pressure.

Described briefly, the improved retracting nozzle unit in its illustrated form comprises a riser pipe carrying on its upper end extension sleeve-like membrane of pliant

2

material, the sleeve preferably being of tapered form. Such sleeve is peripherally secured by its base end to the end of the riser pipe and carries a nozzle head on its opposite end. Such sleeve is normally held in its retracted position drawn within the riser pipe by suitable means such as a return spring. Water pressure reacting against the flexible sleeve causes it to evert, carrying with it the nozzle head to its protracted, operative position. Thus, definite retracted and extended positions of the sleeve are established by the limiting effect of its own extended length, either everted or inverted.

These and other features, objects and advantages of the invention will become more fully evident from the following description thereof by reference to the accompanying drawings.

Figure 1 is a side elevation view illustrating the nozzle unit in its protracted position installed on a riser pipe in a typical underground lawn sprinkler system.

Figure 2 is an enlarged sectional view of the nozzle unit in its preferred form taken on a plane containing its longitudinal axis.

Figure 3 is a top view thereof.

Referring to the drawings illustrating the invention in its preferred embodiment, the underground sprinkler system includes a distribution pipe 10, having a T fitting 12 to which may be connected a riser pipe 14 to support and supply a nozzle unit 16 mounted on the upper end thereof. The upper end of the pipe 14 is situated materially below ground level G where it will not present a hazard, and is preferably closely surrounded by a retaining cup 18 which prevents the soil from caving in around the nozzle unit and the sod from growing over the unit. However, the diameter of the cup 18 is relatively small so that the cavity which it forms is not in itself a hazard. The cup is not an essential.

The nozzle unit, of which the riser pipe 14 in this instance comprises a part, includes a frustoconical membrane 20 of flexible or pliant material, such as a good grade of rubber, plastic or other flexible and preferably weather-resistant pliant material. The larger or base end 20a of the frustoconical membrane is secured peripherally to the end of the riser pipe 14, as by means of a removable clamp or snap band 22 which encircles the membrane and seats it in a retaining groove 24 extending around the exterior of the upper end of the riser pipe. The upper extremity of the pipe is rounded smoothly at 14a to minimize chafing and wear of the membrane. The base diameter of the membrane permits it to be slipped or stretched snugly over the end of the pipe 14 for mounting purposes as described. Preferably it is removable therefrom for maintenance or replacement purposes.

The smaller or opposite end 20b of the membrane carries a nozzle head 26 of any suitable type, which in the example comprises a hollow metal orifice element having a vortex chamber 26a, an upper discharge opening 26b fed from the vortex chamber, swirl ports 26c leading into the vortex chamber 26a, and a base opening 26d feeding the swirl ports. An annular groove 26e around the head 26 serves as a seat for the membrane, and a removable clamp or snap band 28 surrounding the membrane holds it in this seat.

The membrane comprises in effect an extension of the tubular riser 14. In the normal or retracted position of the nozzle unit, the membrane is collapsed or drawn protectively down within the upper end of the riser pipe as illustrated by the solid line showing in Figure 2. The sleeve or membrane may be considered to be inverted in this position. In order to assure that the sleeve will normally be retracted and stored in this position, a helical return spring 30 may be secured at its upper end to a loop 32 on the lower side of the nozzle head 26 and at

3

its lower end to a strut or cross-piece 34 comprising part of a fitting 36 installed in the riser pipe 14 below the nozzle unit. The fitting 36 bears upwardly against a stop or rib 38 extending around the interior of the nozzle pipe and is removably held in that position by a removable snap ring 40 which lodges in a groove 42 in the inside wall of the pipe 14 below the shoulder 38. Spring 30 is of any suitable corrosion resistant metal or other resilient material and has a range of deflection permitting it to stretch far enough to enable the frustoconical sleeve 10 to evert to its broken line position 20' for protraction of the nozzle head 26, as shown at 26'.

Such eversion of the sleeve is effected by introduction of water under pressure into the interior of the pipe 14. During the process of eversion the frustoconical sleeve folds back upon itself passing through a succession of unfolding positions, such as that shown by the dotted lines at 20'', much in the manner of the eversion of a finger stall of a surgeon's rubber glove being pulled from the hand. The broken-line, protracted position 20' represents a limiting position which the nozzle unit is capable of assuming consistently due to the limiting effect of the extended length of the sleeve regardless of any normal differences or variations of water pressure of domestic or municipal water supply systems with which the present invention may be used. In the process of everting of the sleeve any dirt, lawn clippings or other foreign matter which may have accumulated in the well formed by the sealing membrane 20 is, even if caked therein, quite readily dislodged and ejected by forced peeling of the everting membrane from it and by the force of water ejected through the nozzle opening 26b. Closure of the end of the riser pipe 14 effected by the membrane and nozzle head precludes infiltration of dirt or foreign matter into the pipe below the nozzle, which in that location could block the small swirl ports 26c or other nozzle passages when the water pressure is restored in the system. Any dirt that does enter the nozzle opening 26b from its upper end, usually is readily expelled therefrom by the discharging force of the water.

It will be recognized that a sufficiently flexible or pliant membrane 20 and a sufficiently heavy nozzle head 26 carried thereby will cause retraction of the nozzle unit simply by collapse of the sleeve when water pressure is removed, in which case a return spring may not be required. Despite the supple and flexible characteristics of the membrane it nevertheless provides a sturdy and constant support for the nozzle head during operation of the sprinkler, due of course to the expansion force of the water maintaining the sleeve in its expanded, protracted position.

4

Since the nozzle unit is at all times retracted below ground level except when sprinkling, there is no hazard to persons or equipment and little likelihood of damage to the nozzle unit itself. By providing a flexible sleeve of sufficient length the nozzle head may be raised and held at a substantial height above ground automatically for efficient and widespread broadcast of water whenever the pressure is turned on in the system. The automatic and reliable operation of the unit together with its other advantages as mentioned above are such that more satisfactory and widespread use of underground permanent type sprinkler systems are made possible.

It should be recognized, however, that the invention achieving these objectives is not strictly limited to the detailed illustration but may be modified or varied somewhat within the existing skill of the art without exceeding the scope of the novel subject matter.

I claim as my invention:

1. A retractable sprinkler nozzle comprising in combination, a water supply pipe, a substantially rigid tubular member connected at one end to the water supply pipe, a sprinkler nozzle unit supported on the opposite end of said tubular member, said unit including a frustoconical extension sleeve member of flexible material having its base secured peripherally at one end to the said opposite end of the tubular member and extending freely therefrom, a substantially rigid nozzle head of a size smaller than the tubular member attached to the opposite end of said extension sleeve member, and spring means fixed at one end within the tubular member and connected at its other end to the nozzle head to retract the sprinkler nozzle unit within the confines of the tubular member.

2. The combination defined in claim 1, wherein the spring means comprises a helical spring.

3. The combination defined in claim 1, wherein the tubular rigid member consists of a riser pipe and the frustoconical member being attached to the upper end of said riser pipe and the nozzle head secured to the smaller end of the said frustoconical member.

References Cited in the file of this patent

UNITED STATES PATENTS

45	409,796	Magaldi	Aug. 27, 1889
	1,800,858	Buelna	Apr. 14, 1931
	2,510,249	Penksa	June 6, 1950
	2,517,457	Allen	Aug. 1, 1950
	2,554,894	Campbell	May 29, 1951
50	2,628,909	Horan	Feb. 17, 1953