



US00D375237S

United States Patent [19]
Pininfarina

[11] **Patent Number:** **Des. 375,237**
[45] **Date of Patent:** ****Nov. 5, 1996**

[54] **HYDRAULIC WRENCH**
[75] Inventor: **Paolo Pininfarina**, Turin, Italy
[73] Assignee: **Unex Corporation**, Mahwah, N.J.
[**] Term: **14 Years**

Primary Examiner—James M. Gandy
Attorney, Agent, or Firm—Michael J. Striker

[57] **CLAIM**

The ornamental design for a hydraulic wrench, as shown and described.

DESCRIPTION

FIG. 1 is a top plan view of a hydraulic wrench showing my new design;
FIG. 2 is a front elevational view of an alternate embodiment thereof, the only difference residing in the inclusion of a switch in the ribbed area;
FIG. 3 is a right side elevational view of the design of FIG. 1;
FIG. 4 is a rear elevational view of the design of FIG. 1;
FIG. 5 is a left side elevational view of the design of FIG. 1; and,
FIG. 6 is a bottom plan view thereof.

[21] Appl. No.: **51,385**
[22] Filed: **Mar. 8, 1996**
[52] U.S. Cl. **D8/61**
[58] Field of Search D8/61, 68; 81/57.11,
81/57.13, 57.19, 57.36, 57.39, 63

[56] **References Cited**

U.S. PATENT DOCUMENTS

3,273,428	9/1966	Rudeke	D8/61 X
4,825,730	5/1989	Junkers	81/57.36
5,392,671	2/1995	Hazzard	81/57.13
5,522,291	6/1996	Liu	81/177.4

1 Claim, 3 Drawing Sheets

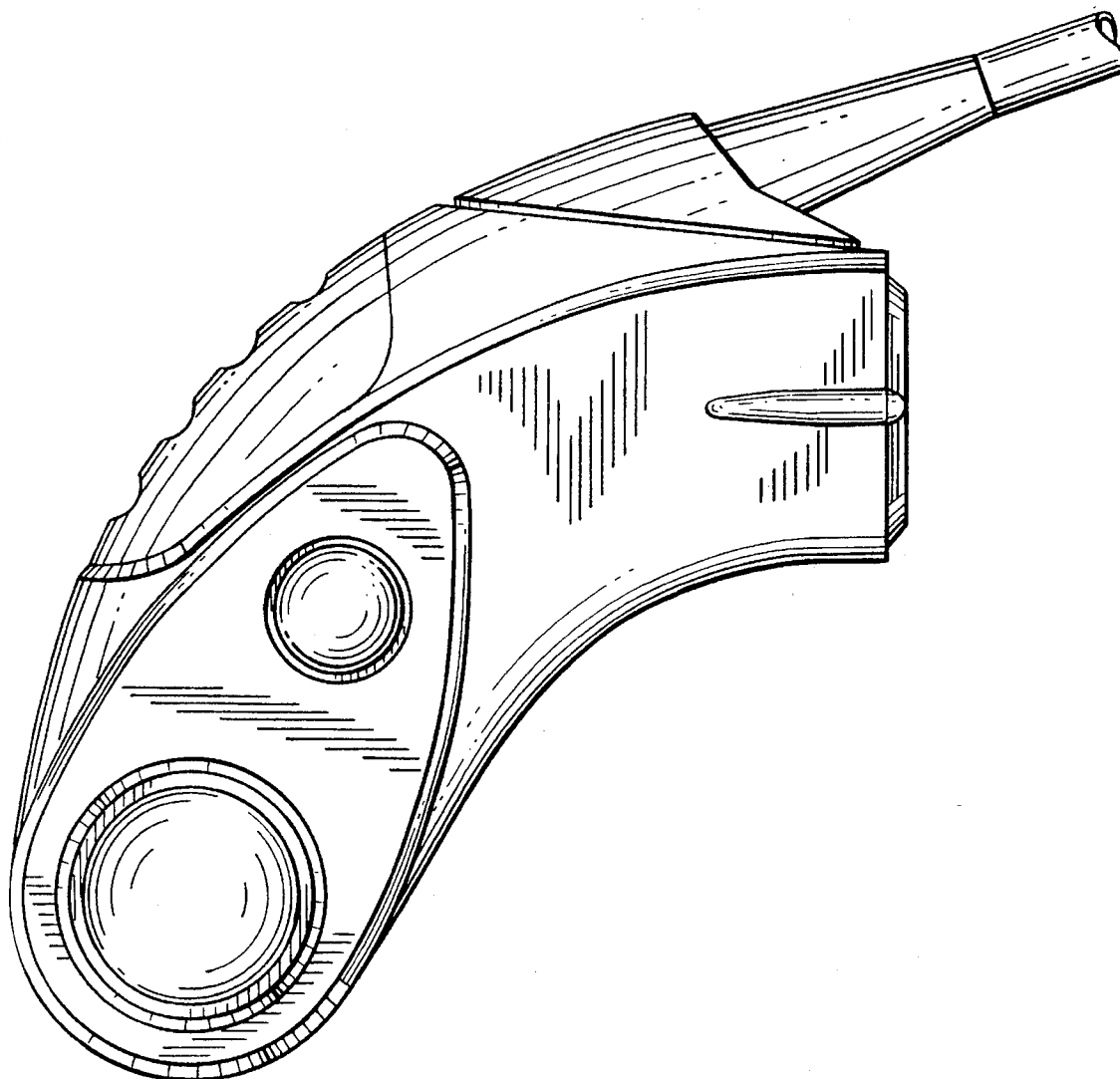

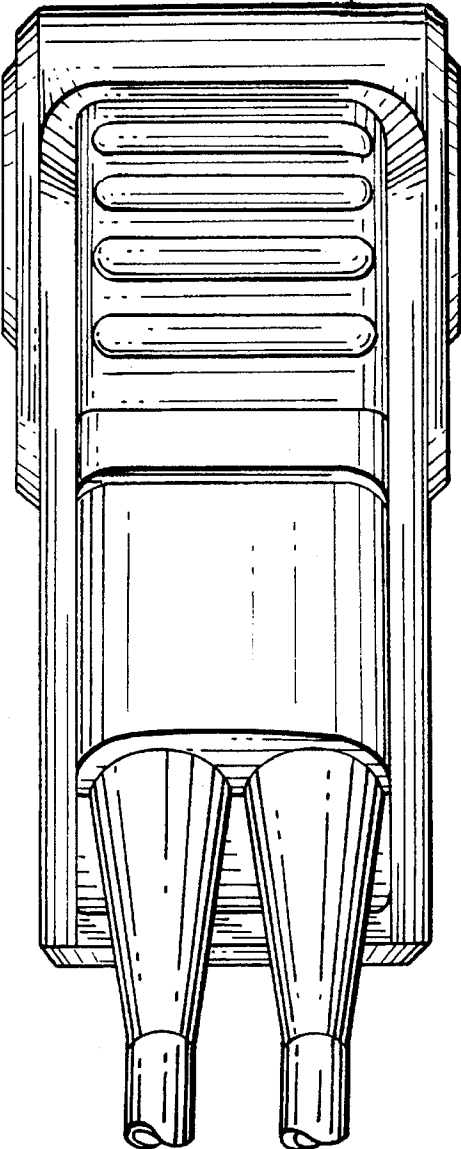

FIG. 1

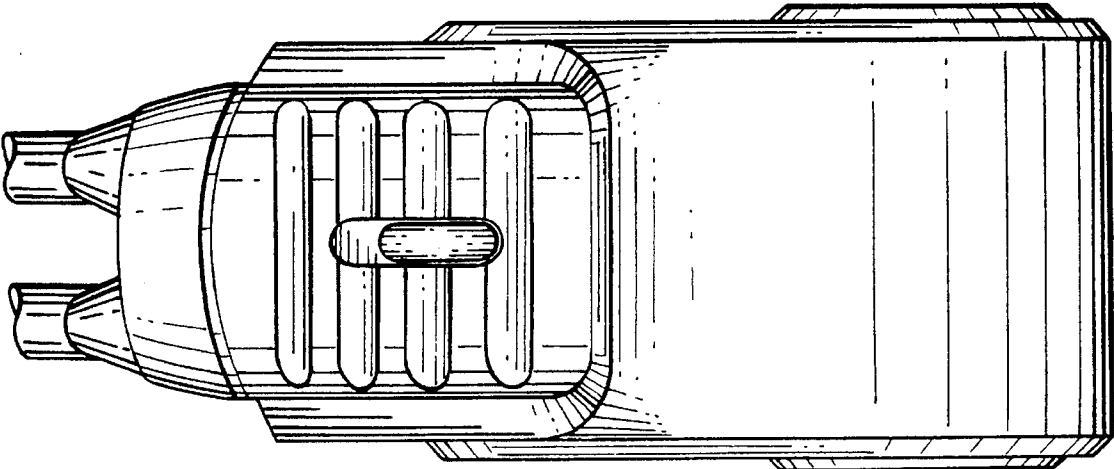

FIG. 2

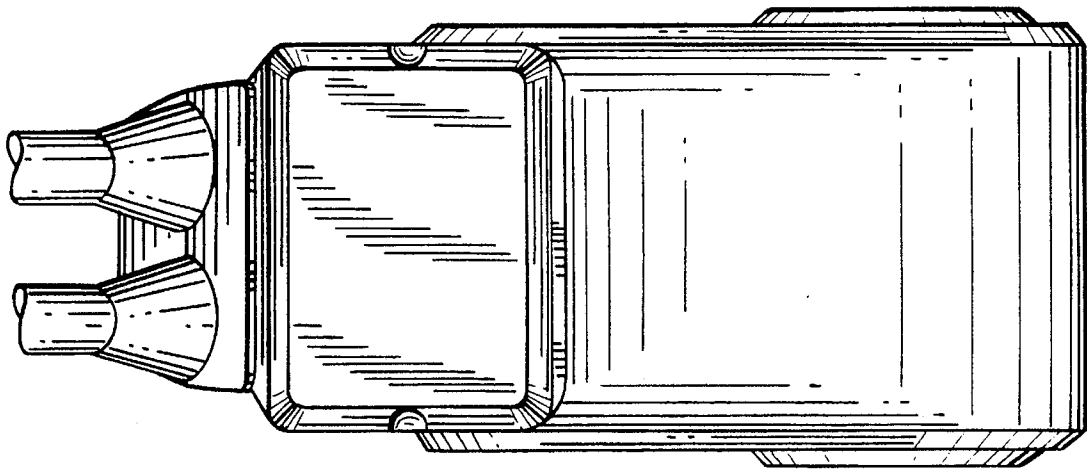

FIG. 4

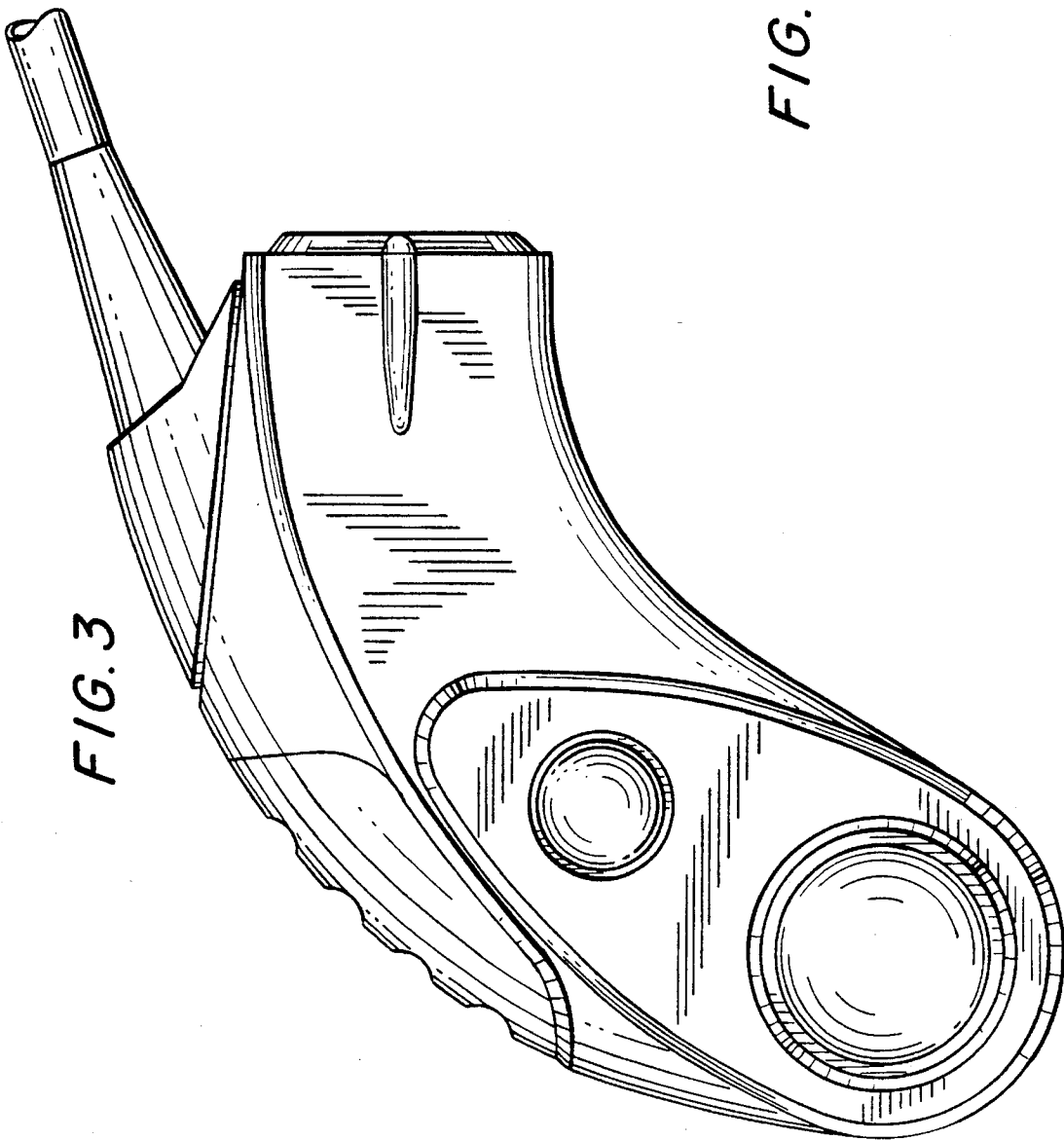

FIG. 3

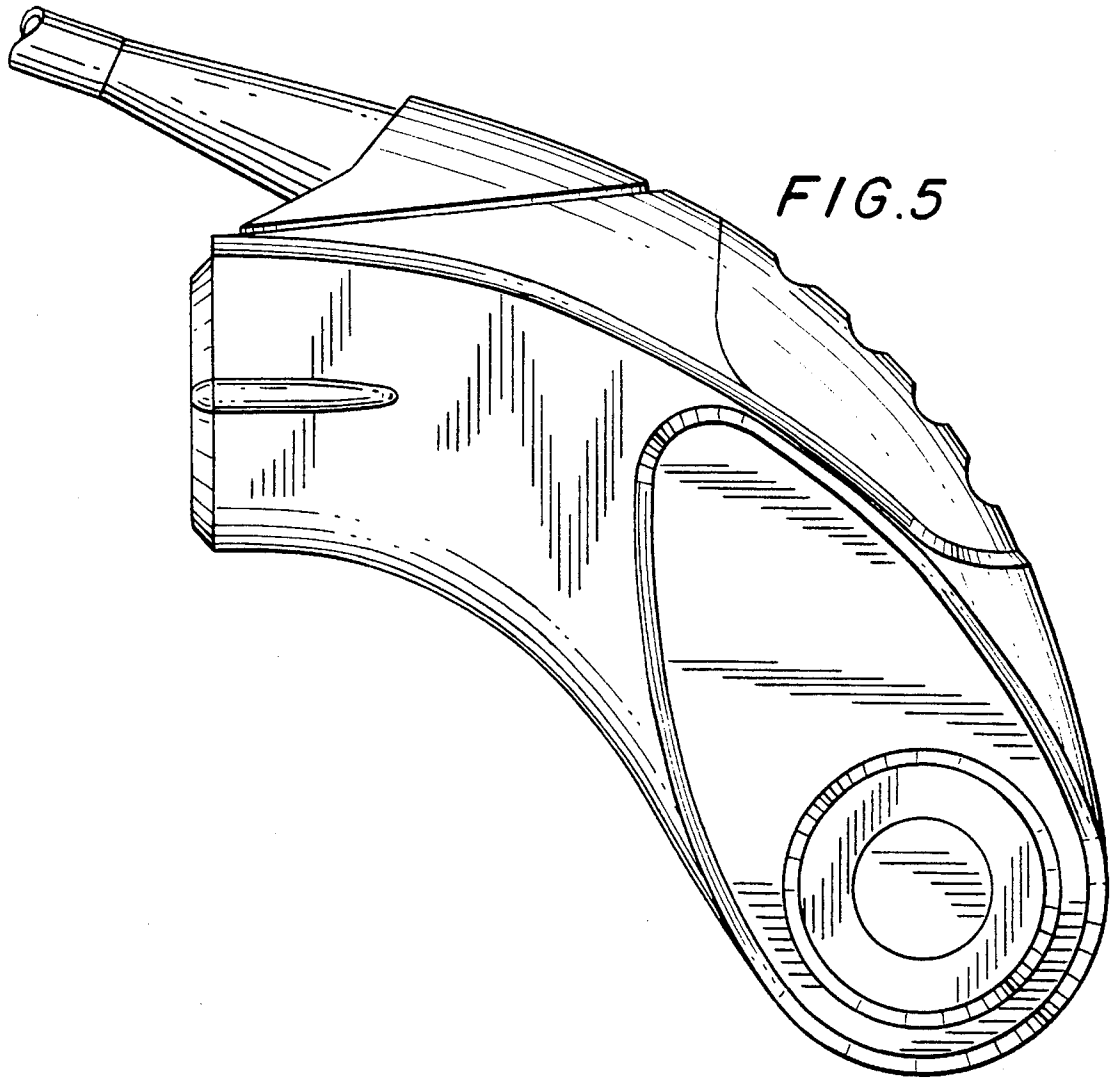

FIG. 5

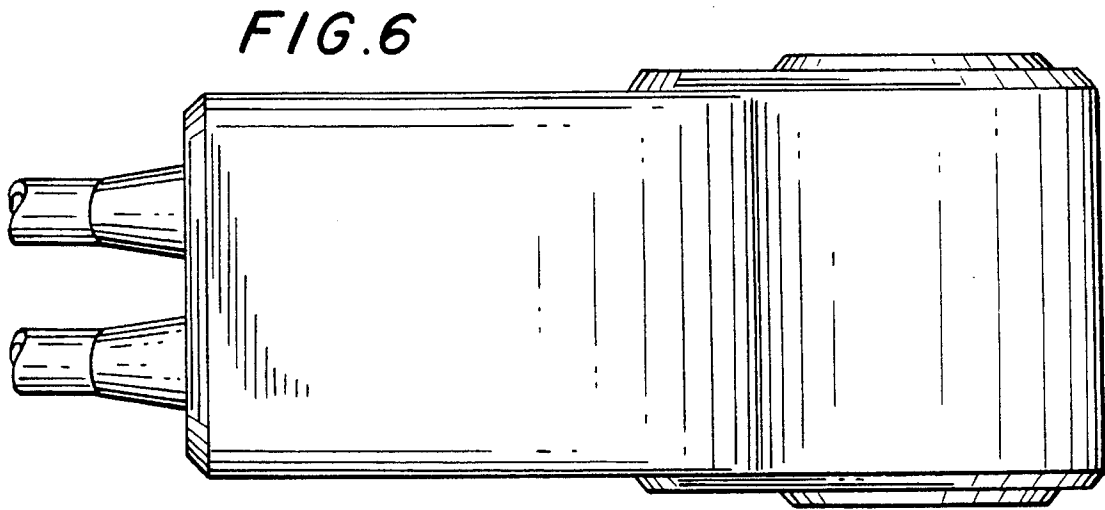

FIG. 6