

(No Model.)

6 Sheets—Sheet 1.

L. C. CROWELL.

METHOD OF AND MACHINE FOR WRAPPING NEWSPAPERS.

No. 522,197.

Patented July 3, 1894.

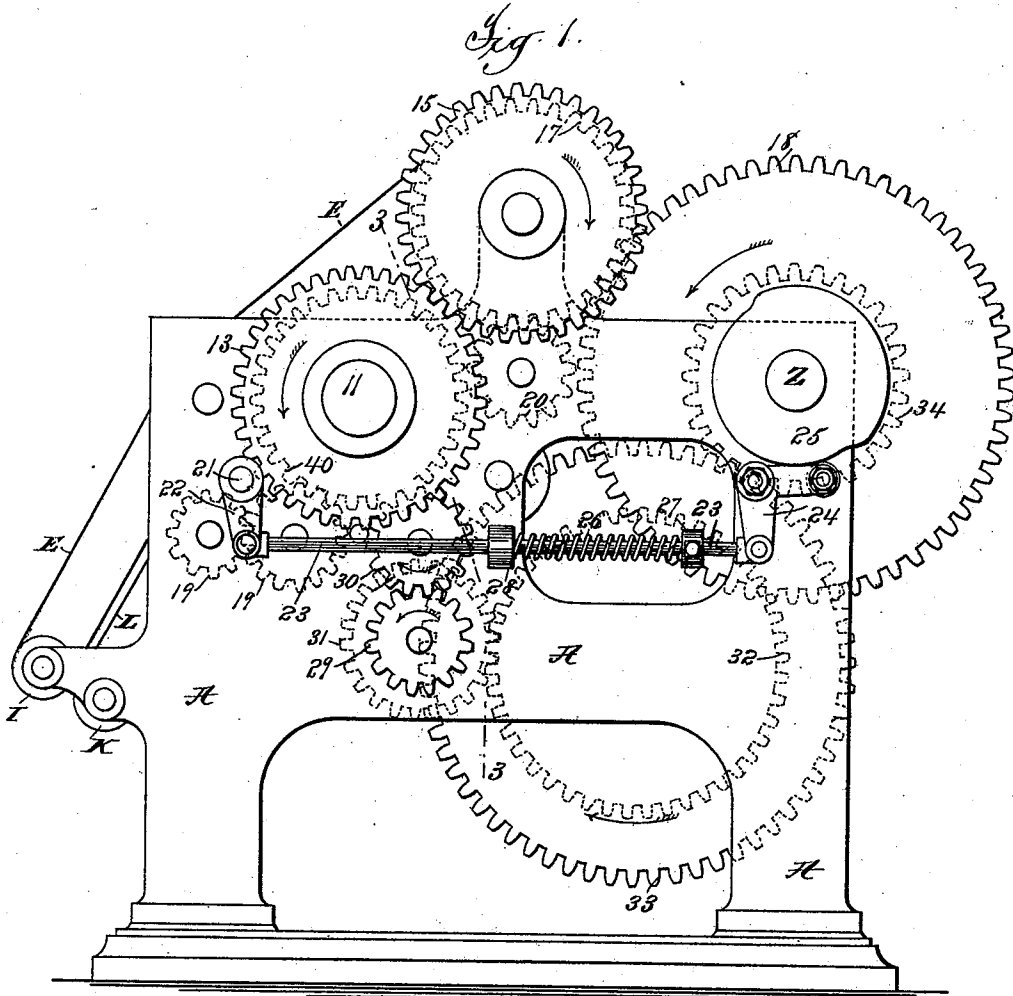

Attest:
 Geo. H. Potts
 C. J. Sawyer

Inventor:
 Luther C. Cornee
 by
 Phelps, Munson & Phelps
 Attys

(No Model.)

6 Sheets—Sheet 2.

L. C. CROWELL.

METHOD OF AND MACHINE FOR WRAPPING NEWSPAPERS.

No. 522,197.

Patented July 3, 1894.

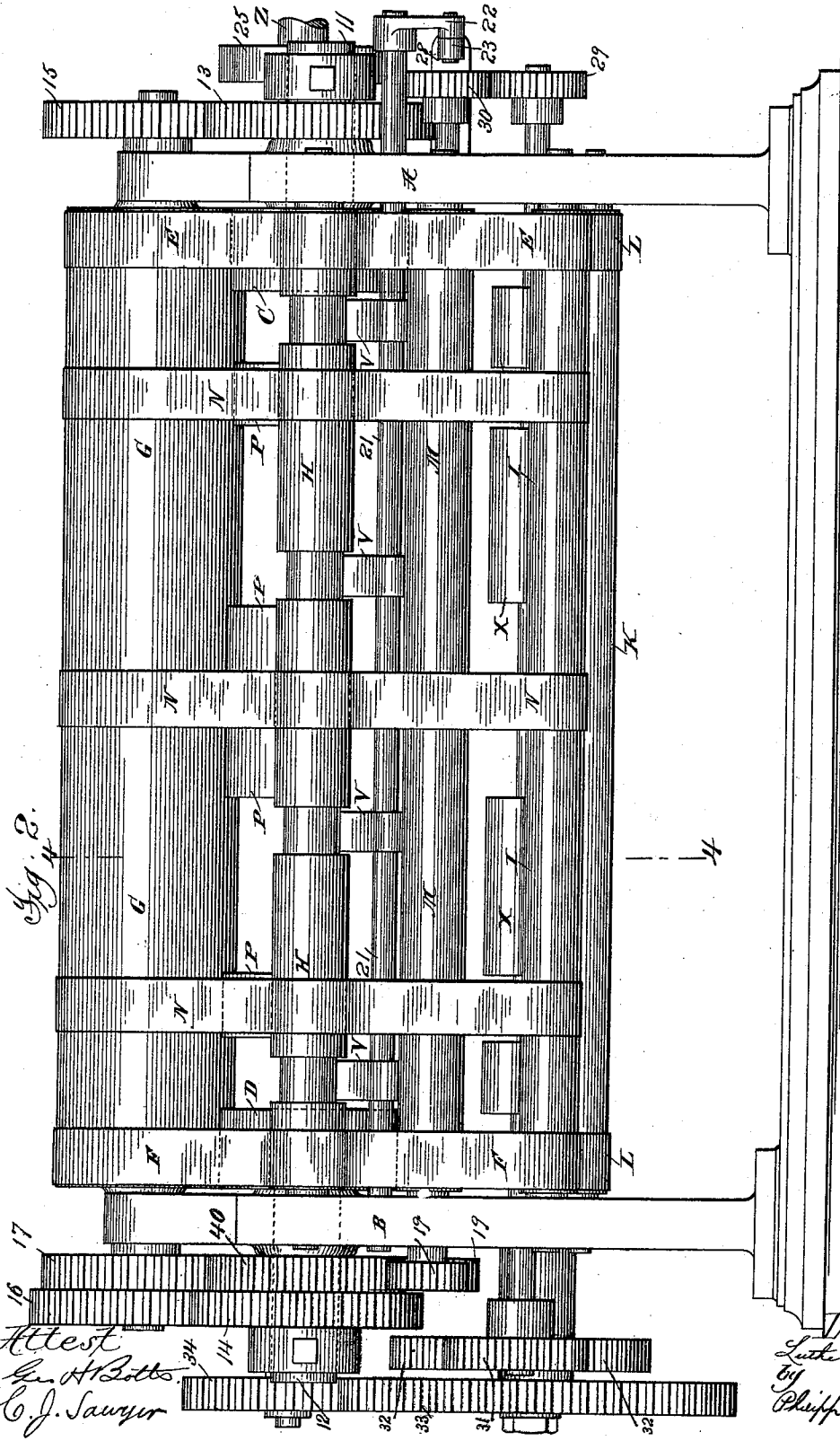

Fig. 2.

*Attest
Geo. H. Zotto
C. J. Sawyer*

*Inventor
Luther C. Crowell
By
Philip M. Mumford
Attys*

(No Model.)

6 Sheets—Sheet 3.

L. C. CROWELL.

METHOD OF AND MACHINE FOR WRAPPING NEWSPAPERS.

No. 522,197.

Patented July 3, 1894.

Fig. 3.

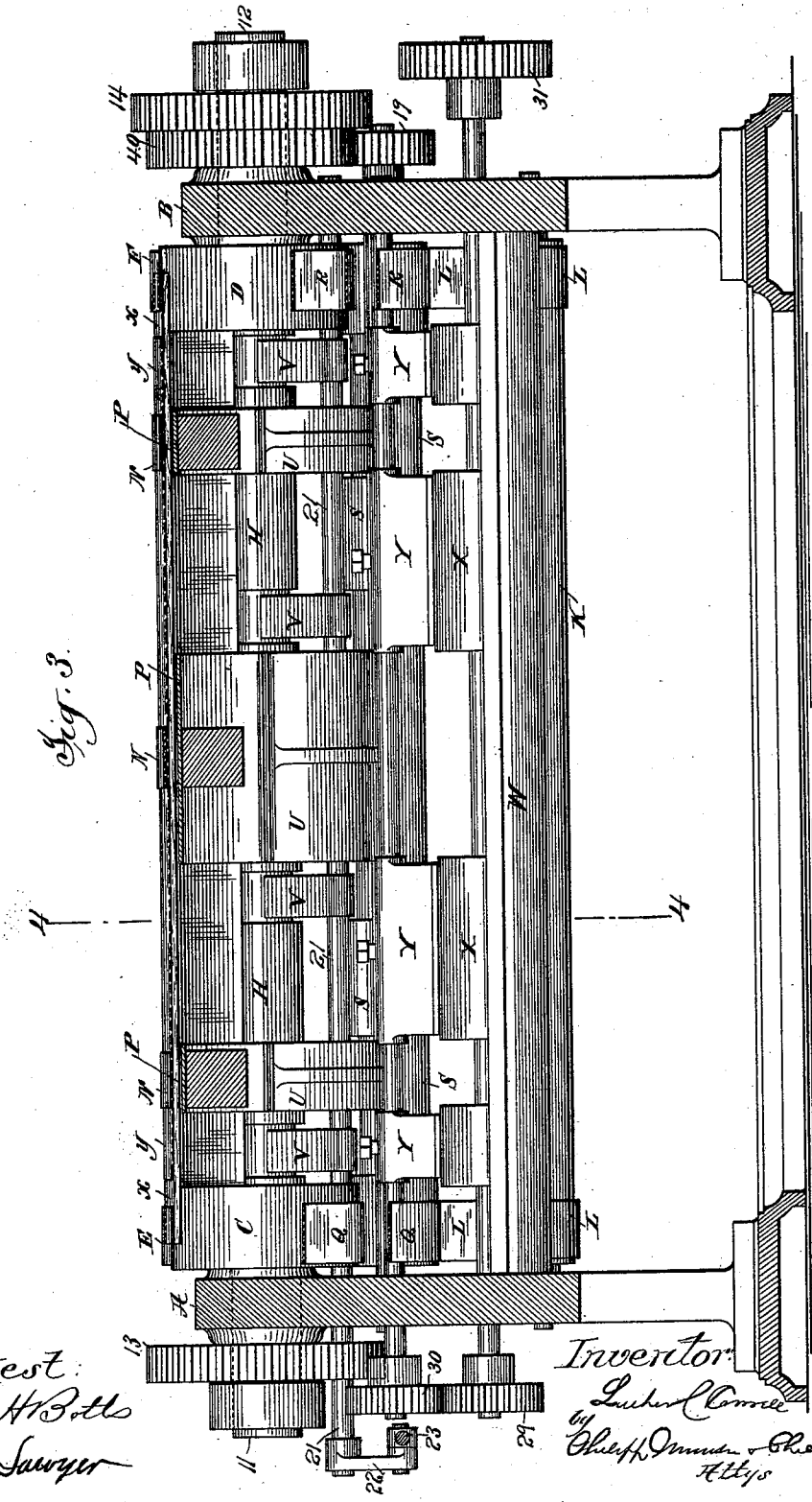

Attest:
Geo. H. B. Bells
C. J. Sawyer

Inventor:
Luther Crowell
 by *Chas. H. Dunning & Co.*
Attys

L. C. CROWELL.

METHOD OF AND MACHINE FOR WRAPPING NEWSPAPERS.

No. 522,197.

Patented July 3, 1894.

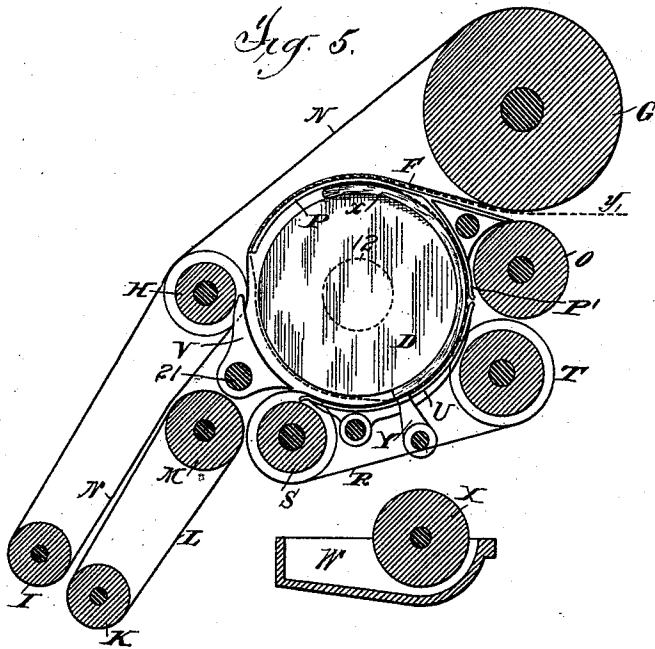
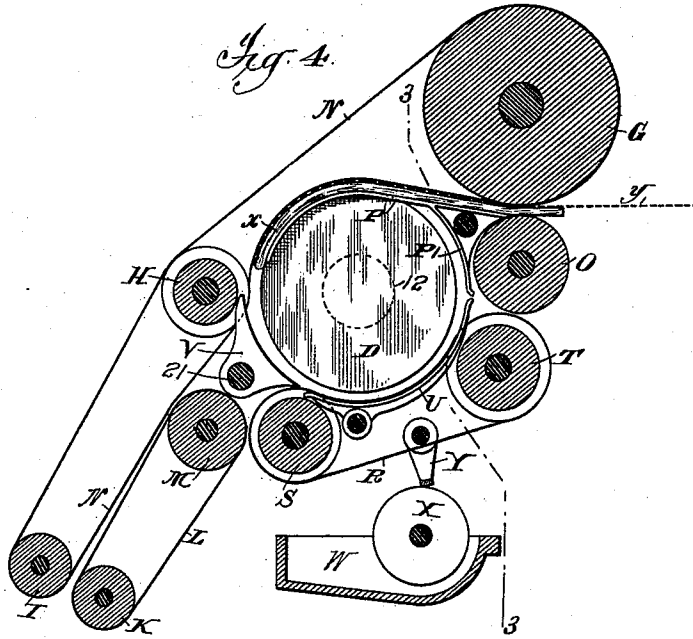

Attest:
 Geo. H. Potts.
 C. J. Sawyer

Inventor:
 Luther C. Crowell
 by
 Phelps, Munson & Phelps
 Attys.

L. C. CROWELL.

METHOD OF AND MACHINE FOR WRAPPING NEWSPAPERS.

No. 522,197.

Patented July 3, 1894.

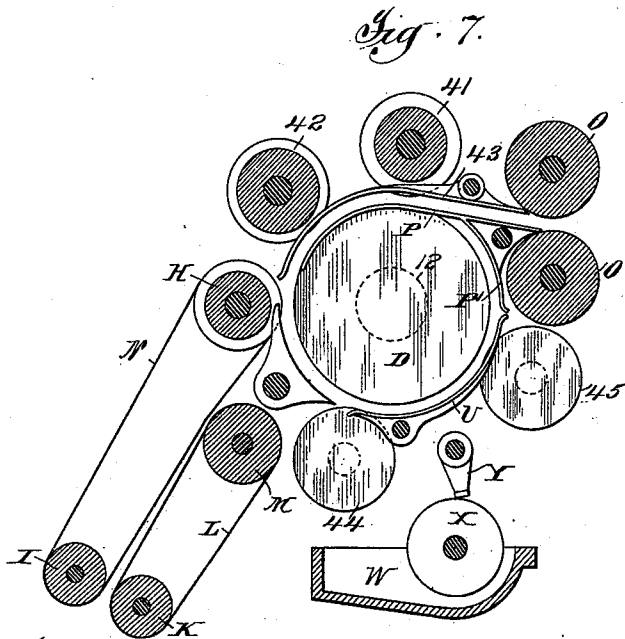
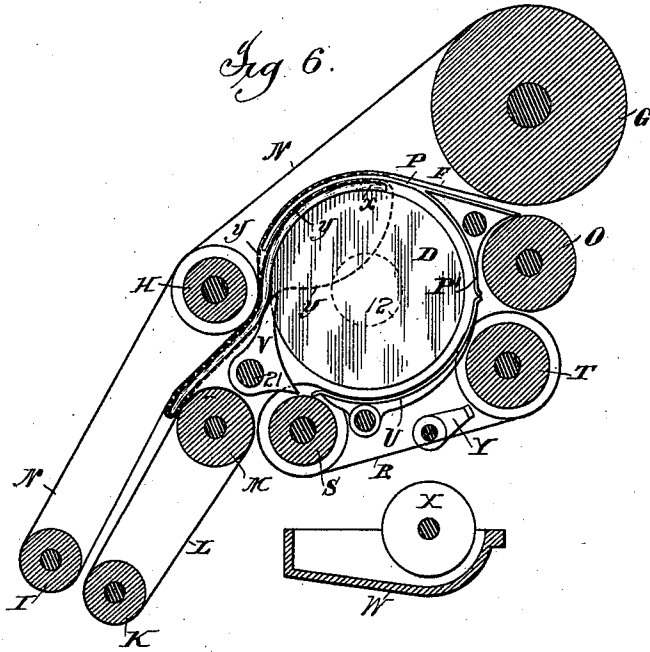

Attest:
 Geo. H. Botts
 C. J. Sawyer

Inventor:
 Luther C. Crowell
 by
 Philip J. ...
 Atty

L. C. CROWELL.

METHOD OF AND MACHINE FOR WRAPPING NEWSPAPERS.

No. 522,197.

Patented July 3, 1894.

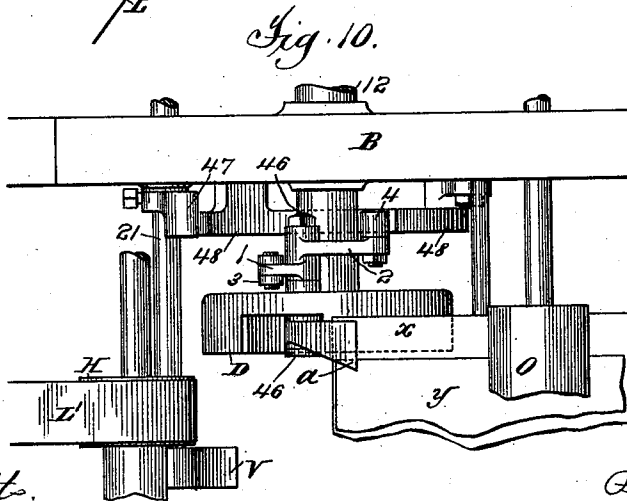
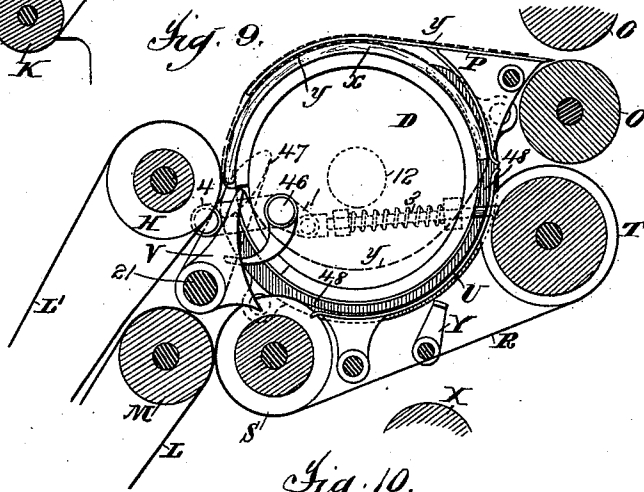
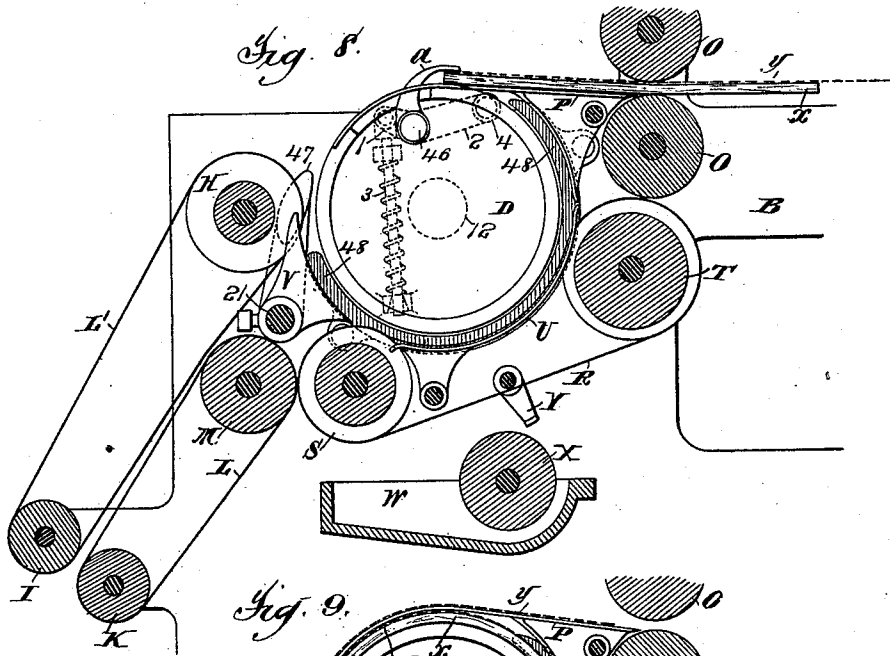

Attest:
 Geo. N. Bolts.
 C. J. Sawyer

Inventor
 L. C. Crowell
 by
 Phlipps, Munroe & Phelps
 Attys

UNITED STATES PATENT OFFICE.

LUTHER C. CROWELL, OF BROOKLYN, ASSIGNOR, BY DIRECT AND MESNE ASSIGNMENTS, TO ROBERT HOE, THEODORE H. MEAD, AND CHARLES W. CARPENTER, OF NEW YORK, N. Y.

METHOD OF AND MACHINE FOR WRAPPING NEWSPAPERS.

SPECIFICATION forming part of Letters Patent No. 522,197, dated July 3, 1894.

Application filed February 20, 1892. Serial No. 422,191. (No model.)

To all whom it may concern:

Be it known that I, LUTHER C. CROWELL, a citizen of the United States, residing at Brooklyn, county of Kings, and State of New York, have invented certain new and useful Improvements in Methods of and Machines for Wrapping Newspapers and other Publications, fully described and represented in the following specification and the accompanying drawings, forming a part of the same.

The object of the present invention is to provide an improved method of wrapping newspapers and other publications, and an improved machine of that class used for this purpose and known as newspaper wrapping machines, and especially to increase the speed at which such publications may be wrapped, and to provide a simple and efficient machine of high capacity.

By the method forming part of the present invention, I roll the paper and wrapper together to form a cylinder and then lead off the paper and wrapper by their leading ends with the rear end of the wrapper overlapping the first layer of wrapper upon the paper, so as to be pasted down and secured by suitable pressing devices, and in carrying out my invention I preferably wind the paper and wrapper upon a core which supports the paper only through a portion of its width, and apply the wrapper to that part of the paper not directly supported by the core, so that the curve on which the paper is rolled is determined by the core while at the same time the leading ends of the paper and wrapper may be led off the core to the pressing devices with the rear end of the wrapper overlapping the first layer of wrapper upon the paper, by the portion of the wrapper not supported by the paper being carried in against the paper as the latter changes from cylindrical to flat form. It is evident that this method employing a core may be carried out by machines of widely different constructions, it being necessary for a hand-fed machine only to provide a core and suitable means for winding the paper and wrapper thereon and feeding and pressing devices by which the paper and wrapper are delivered from the core and the wrapper pasted down, and the addition of

pastings mechanism and feeding devices for advancing the papers and wrappers to the core in proper time producing a machine entirely automatic in its operation and of high capacity. In carrying out my invention, however, I preferably employ a rotating core, by which the paper is supported through only a portion of its width, this core being formed preferably of two cylinders supporting the paper at its opposite side edges, and apply to the portion of the paper between the cylinders the wrapper, which is of less width than this portion of the paper. The length of the paper is substantially one-half of the periphery of the core and the wrapper of sufficient length to extend completely about the paper on the core and overlap upon the first layer of wrapper sufficiently for pasting. The leading ends of the paper and wrapper are taken by the core simultaneously and the paper and wrapper are wrapped upon the core during one rotation of the latter and upon the second rotation are led from the core by suitable feeding devices, the part of the wrapper not supported by the paper being carried in so as to lie against the paper, and the rear end of the wrapper overlapping the first layer of wrapper upon the paper is pressed down by suitable pressing devices, so as to be pasted by paste previously applied either to the rear end of the wrapper or to the first layer of wrapper upon the paper, the wrapped paper thus being delivered as a flat product.

It is evident that the construction thus briefly outlined may be varied widely, that any suitable means may be used for securing the winding of the paper and wrapper upon the core during the rotation of the latter, and that the leading ends of the paper and wrapper may be advanced by positive engagement by the core or by friction between the core and feeding devices co-operating therewith. The means for delivering the paper from the core and pressing the paper for pasting to form a flat product also may be of any suitable form. I prefer, however, to use for advancing the paper and wrapper, feeding devices co-operating with the core, so that the paper and wrapper are advanced without being positively gripped, and I preferably em-

55

60

65

70

75

80

85

90

95

100

ploy as the feeding devices belts moving in the same direction and at the same speed as the core, so as to co-act therewith in advancing the paper and wrapper. In delivering the
 5 paper and wrapper from the core, I preferably employ a switch, which allows the paper and wrapper to pass with the core in its first rotation and is shifted on the second rotation into position to guide the paper and
 10 wrapper from the core and into the grasp of delivering tapes or similar feeding devices, by which the pasted wrapper is secured by pressure and the wrapped paper delivered as a flat product. With this construction I combine a pasting mechanism, which preferably
 15 is adapted to apply paste to the layer of wrapper upon the paper during the first rotation of the core.

As it is evident that the paper is not folded during the wrapping operation of this machine, it must be folded down to the required length before delivery to the wrapping devices, and this folding, of course, may be accomplished in the same machine, or the papers may be folded previously and the wrapping mechanism form an independent machine, which may be fed by hand or suitable feeding devices. Thus the wrapping mechanism may be combined with the delivery
 20 mechanism of a printing press or with a folding machine of any of the common forms, wrapper feeding and pasting mechanisms being added so that the folded paper is automatically wrapped and delivered, or wrapper
 25 and paper feeding devices of any suitable form may be combined with the wrapping mechanism to form an independent paper or pamphlet wrapping machine.

In the accompanying drawings, forming a part of this specification, I have shown a complete automatic machine embodying my invention in its preferred form, and certain modifications thereof, and a full description of the same will now be given in connection
 30 with the drawings and the features forming my invention specifically pointed out in the claims.

Referring to the drawings:—Figure 1 is an end elevation of the machine. Fig. 2 is a side elevation, looking to the right in Fig. 1, showing the delivery side of the machine. Fig. 3 is a vertical longitudinal section taken on the line 3 of Fig. 4, showing the wrapping mechanism from the feeding side. Fig. 4 is a cross section on the line 4 of Figs. 2 and 3 showing the parts in the same position as the general views and as the wrapping of the paper is commenced. Fig. 5 is a similar view, showing the parts after one rotation of the core. Fig. 6 is a similar view, showing the parts during the delivery of the wrapped paper. Fig. 7 shows a modification employing rolls as feeding devices in place of tapes. Figs. 8 and 9 are sections similar to Figs. 4 to 6, showing a modification in which the paper and wrapper are positively gripped by the core, the parts being shown in different posi-
 35
 40
 45
 50
 55
 60
 65

tions during the operation of wrapping, and Fig. 10 is a detail plan of one end of this modified wrapping mechanism.

The frame of the machine may be of any suitable form to support the operating parts. As shown, it consists of the two end frames A, B, in which all the parts of the machine are supported. The core upon which the paper and wrapper are wound consists of two short cylinders C, D carried by shafts 11, 12, mounted in the opposite end frames A, B, and in the upper part of the machine, the cylinders extending within the frames so as to engage and support the paper at its opposite side edges. With the cylinders C, D co-act belts E, F, extending partially about the cylinders from the side on which the paper is received, these belts being driven from a roll G mounted in the frames A, B above the cylinders. These belts are guided about the upper part of the cylinders under a roll H mounted in the frame, and are returned about a roll I and over the roll H, the roll I forming one of the delivery rolls I, K, of the machine, the belts E, F, thus acting as feeding belts in combination with the cylinders to wind the paper about the core, and forming also one set of the delivery belts, by which the wrapped paper is delivered, the other set consisting of a series of short belts L extending about the second delivery roll K and driven from a belt driving roll M. The belts E, F, may be formed to extend inside the cylinders C, D and engage the wrapper so as to feed it forward with the paper, but in the construction shown a series of independent belts N are used for this purpose, these belts being led over rolls G, H, I, and driven by roll G in exactly the same manner as belts E, F so as to form part of the delivery belts between the rolls H, I.

The roll G co-acts with a roll O mounted in the frames A, B, below it to form a pair of feeding rolls by which the leading ends of the paper and wrapper are received and advanced over guides P to the core. These guides P are curved parallel with the circumference of the cylinders C, D and the line of movement of the paper and wrapper, and lie between the cylinders, extending about the core nearly to the roll H, and are constructed, as shown, so as to extend backward from the point at which the paper and wrapper are received to form guides P' by which the paper upon the core is guided during a portion of its rotation when the leading end is not engaged by any of the feeding belts, although it will be understood that separate guides may be provided for this purpose if desired.

The guides P are preferably made of spring metal so as to yield slightly as the paper is led above and below them and thus accommodate papers of different thicknesses, and the belts N co-operate with the guides P to advance the rear end of the wrapper during the delivery of the paper.

Feeding belts Q, R, are provided below the

cylinders C, D corresponding in position and action to the belts E, F, above the cylinders. These belts are driven from roll S and led about roll T. A series of guides U corresponding to the guides P, are provided opposite the belts Q, R, between the cylinders C, D, these guides acting to guide the leading ends of the paper and wrapper and extending in the line of movement of the core to the rear end of the guides P', so that the paper and wrapper are positively guided thereby and the wrapper held pressed against the surface of the paper during the rotation of the core.

Between the rolls H, S is mounted a switch V carried by rock shaft 21 adapted to be rocked so as to throw the switch from the position shown in Fig. 4 in which the paper and wrapper are guided about the core from the roll H to the belts Q, R during the first wrapping rotation of the core to the position shown in Fig. 6 in which the leading ends of the paper and wrapper are guided off to the delivery belts during the second delivering rotation of the core.

The switch V consists preferably of a series of fingers extending in opposite directions, and forming guides for the paper and wrapper, the rolls H, S being grooved to accommodate the fingers, so that the full space between the rolls H, S is filled by the switch. A plate extending over the full space occupied by the fingers shown may be substituted, however, if desired, the rolls H, S, being so positioned that the switch may move through a sufficient arc for guiding the paper from the core.

The paste may be applied to the rear end of the wrapper prior to the wrapping operation or in the machine before reaching the rolls G, O, but I preferably apply the paste to the wrapper upon the paper on the first rotation of the core so that on the second rotation and delivery of the paper the rear end of the wrapper will be pressed down upon the pasted portion of the first layer of the wrapper. For this purpose I provide a paste fountain W, and fountain roll X by which paste is applied to a rotating paster Y mounted in position and arranged to apply paste to the desired portion of the paper. As shown, the paste is applied to the rear end of the paper, the wrapper being of a length three times that of the paper, although it will be understood that the wrapper may be shorter, and the paste applied to any other desired portion of the paper. The paster Y is constructed to apply paste to the portions of the paper between the guides U, and the guides P are cut away to correspond with the guides U so that the pasted portions of the paper will pass forward out of engagement therewith, but will be brought into contact with the wrapper as the leading end of the paper and wrapper pass beneath the guides P on the second rotation. The operating parts of the machine are driven from the main driving shaft Z by the following connections:—The shafts 11, 12 of the

cylinders C, D, are provided with gears 13, 14 which are engaged respectively by gears 15, 16 carried by the shaft of roll G. The roll G carries also at one end inside the gear 16 a second gear 17 which engages a large driving gear 18 carried by the main driving shaft Z. As will be seen, the gears are so timed that the cylinders E, F are rotated twice to each rotation of the main driving shaft Z, and the belts E, F, N driven by roll G move at the same rate of speed as the cylinders. The belts L, Q, R are driven from the rolls M, S, which are geared together by gears 19, and driven from core D by gear 19 on roll S meshing directly with gear 40 on shaft 12. The feeding roll O is driven directly from the roll G by a gear 20 engaging with gear 17. A uniform speed is thus secured for all the parts co-acting with the core in advancing and delivering the paper.

The switch V is carried by a rock shaft 21 mounted in the side frames A, B and provided outside the frame A with a crank arm 22 connected by a pitman 23 with a bell crank lever 24 pivoted on the frame A, the other arm of which carries a bowl which rides upon a cam 25 carried by the main driving shaft Z. The shaft 21 is normally rocked into position to hold the switch in the position shown in the main views and Figs. 4 and 5 by a coiled spring 26 on the pitman 23 held between the adjustable collar 27 on the pitman and a lug 28 on the frame A through which the pitman slides. The cam 25 is so constructed as to hold the switch in the position shown in Figs. 4 and 5 during the first rotation of the core, and a portion of the second, and then to throw the switch into the position shown in Fig. 6 so as to guide the leading end of the paper and wrapper between the rolls H, M, and the delivery belts, the switch at the same time operating to throw in the unsupported part of the wrapper against the body of the paper, the paper and wrapper being pressed between the switch fingers and the roll H, and fed by friction between the two until they reach the roll M and are grasped by it and the belts E, F, N.

The pasting mechanism is operated as follows:—The shaft of the paste fountain roll X carries gear 29 which meshes with a gear 30 on the shaft of the paster Y. The shaft of the fountain roll carries also a larger gear 31 which meshes with a gear 32 carried by a stud mounted in frame B, and which carries also a large gear 33 which meshes with a gear 34 on the main driving shaft Z, these gears being so timed, as shown, that the paster rotates in unison with the main driving shaft, and, therefore, rotates once to each two rotations of the cylinders C, D forming the core, the paste thus being applied during the first rotation of the core with the paper and wrapper thereon.

The operation of the machine will be understood from a brief general description in connection with the drawings and the detailed description of the parts above given.

As shown in the main views and Fig. 4, the paper α and wrapper γ have been received by the belt roll G and feeding roll O and advanced thereby over the guides P to the cylinders C, D forming the core and the belts E, F co-operating therewith, the paper being of such a width as to overlap upon the cylinders, and the wrapper of less width so as to lie entirely between the cylinders and be advanced by friction between the belts N and the paper as shown in Fig. 3. On the first rotation of the cylinders the switch V is held in position as shown in Fig. 4, and the paper and wrapper are wound upon the core, passing inside the switch and being held upon the core during this rotation by the belts R and guides U, P', paste being applied by paster Y to the layer of wrapper upon the paper in proper position for pasting, all as shown in Fig. 5, in which the core is shown as just commencing the second rotation. Upon the second rotation of the core the leading end of the paper and wrapper is carried under the guides P, and, as shown in Fig. 5, the rear end of the wrapper overlaps upon the layer of wrapper on the paper so that the two layers of wrapper are in contact between the guides P, to which space the paste has been applied to the layer of wrapper upon the paper by the paster Y. As the second rotation of the core continues and the leading end of the paper approaches the switch V, the switch is actuated by the cam 25 and connections previously described and thrown into the position shown in Fig. 6, so that it operates to guide the leading end of the paper and wrapper from the cylinders to the delivery belts E, F, N, L, the switch V co-acting with the roll H and belts F, N to advance the paper until it is gripped by the roll M and delivery belts. As the leading end of the paper and wrapper is thus led from the core, the loose portion of the wrapper is carried inward onto the inner surface of the paper as shown in dotted lines in Fig. 6, and as the paper and wrapper are advanced between the delivery belts the rear end of the wrapper is pasted down upon the the layer of wrapper on the paper and the paper delivered in flat form between the rolls I, K, the pasted portion of the wrapper being pressed a sufficient length of time by the delivery belts and rolls so that the wrapper is firmly secured upon the paper.

In the construction shown, the length of the paper is substantially one half the periphery of the core, so that the portion of the wrapper about the core not supported by the paper is substantially the length of the paper and is simply carried inward against the paper in delivering. While this construction is preferred, however, it will be understood that a longer paper may be wrapped, provided the grip of the delivery devices be loose enough to allow the wrapper to slip therein as the paper is straightened out, so as to draw up the rear end of the wrapper to afford suf-

ficient wrapper to extend about the flattened paper. In the machine shown, however, in which the leading ends of the paper and wrapper are guided off the core to the delivery mechanism by a switch, the length of the paper must be somewhat less than the periphery of the core, and a better action is secured by making the length substantially one half the periphery of the core, as shown.

While I have shown as the preferred construction a machine in which the paper and wrapper are gripped by belts co-acting with the cylinders to advance the paper and wrapper, it is evident that I may use other feeding devices in place of the belts. Thus I have shown in Fig. 7 a construction substantially the same as that previously described, except that the belt roll G and belts carried thereby are omitted and the paper and wrapper are advanced to the wrapping mechanism by two feeding rolls O, and in place of the belts E, F, N co-acting with the cylinders C, D to advance the paper and wrapper, I use feeding rolls 41, 42 and a second set of guides 43 outside the guides P, these feeding rolls 41, 42 being grooved and cut away opposite the guides 43, as shown, so as to project inside the guides and grip the paper and wrapper in the same manner as the belts E, F, N. In place of the belt rolls S, T and belts R on the other side of the core, I use short rolls 44, 45 co-acting with the cylinders C, D forming the core, the wrapper being held and guided by the guides U as the paper is advanced by the cylinders and rolls. The operation of this construction is identical with that previously described, the feeding rolls simply being substituted for the belts as feeding devices, and no further description is necessary.

While I prefer to employ feeding devices which co-act with the cylinders C, D to advance the paper by friction, it is evident that my invention may be embodied in a construction in which the paper and wrapper are positively gripped by the core and carried with it during the first rotation and released on the second rotation to allow them to be guided from the core for delivery. Such a construction is shown in Figs. 8, 9 and 10, in which each of the short cylinders C, D forming the end cores is provided with a gripper α operating to seize the leading end of the paper and wrapper. These grippers α may be of any suitable form and arranged in any suitable manner to allow the paper and wrapper to be led from the core but I prefer the construction shown, in which the grippers are cut away on their inner sides so as to form an inclined surface and are so mounted as to grip the paper against the cylinder over a considerable surface but to hold the wrapper against the paper only by a small surface at the inner point of the grippers. With this construction the wrapper will readily slide off the gripper without tearing, as the paper is re-

moved in the manner shown in Fig. 6 and the loose part of the wrapper carried inward against the body of the paper.

The grippers *a* may be mounted and actuated in any suitable manner to secure their proper movement for gripping the paper and wrapper during the first rotation of the cylinder and releasing them during the second rotation for the delivery of the wrapped paper. I have shown a common construction of gripper mounting, in which the grippers *a* are carried by short shafts 46 mounted in the cylinders C, D and provided with crank arms 1, 2 extending in opposite directions, the former of which is spring pressed by the common spring pressed rod 3 to close the gripper, and the other of which carries a bowl 4 running on a cam for operating the gripper.

It is evident that the cam must be so formed that the gripper shall remain closed during the first rotation of the core, be opened on the second rotation for the delivery of the paper, and be again in position to seize a paper and wrapper at the beginning of the next rotation. This result I obtain by the following construction: The shaft 21 carrying the switch V carries also a cam 47 mounted on an arm on said shaft. This cam lies outside the path of movement of the bowl 4 when the switch V is in position to guide the paper and wrapper onward with the core but on the rocking of the shaft 21 to carry the switch inward for the delivery of the wrapped paper, it is carried inside the path of the bowl so that the latter rides upon the outside of the cam and the shaft 46 is rocked against the tension of the spring on rod 3 to open the gripper for the release of the head of the sheet and wrapper. A circular cam 48 extends from the cam 47 to the opposite side of the cylinder and is so positioned that the bowl 4 during the first rotation rides upon the inner side of said cam and the gripper is held in its closed position by spring pressure. When the bowl 4 passes off the outer side of cam 47 in opening the gripper, however, it passes onto the outer surface of the circular cam 48, as shown in Fig. 9, and runs upon this outer surface during the rest of that rotation and until the gripper is in position to seize another sheet, when the bowl 4 passes off the point of the cam 48 into the position shown in Fig. 8, and the gripper is closed by the spring on rod 3 in the usual manner. It will be understood that with this construction the tapes E, F, N need not be used, but the paper and wrapper are held by the grippers until they are seized between roll H and cylinders C, D, as shown in Fig. 9, a second series of delivering tapes L' extending from roll H to delivering roll I being provided. One or more tapes extending between rolls O, H, and corresponding to tapes N in the constructions previously described for securing the proper feed of the wrapper may be used, however, if found necessary in any case.

It will be understood that many other modifications may be made in the constructions shown by those skilled in the art without departing from my invention.

While I have described my invention as applied in wrapping newspapers and other publications, it will be understood that the method and machine of my invention may be applied to wrapping other articles which can be rolled into cylindrical form and that such uses are within my invention.

What I claim is—

1. The method of wrapping newspapers and other publications, which consists in winding the paper and wrapper upon a core of less length than the width of the paper, with the wrapper applied to that part of the paper not supported directly by the core, leading off the paper and wrapper from the core with the rear end of the wrapper overlapping the first layer of wrapper upon the paper, and pressing down the overlapping portion of the wrapper for pasting, substantially as described.
2. The method of wrapping newspapers and other publications, which consists in rolling the paper and wrapper into a cylindrical form with the circumference greater than the length of the paper, leading off the paper and wrapper from the rolling space by their leading ends with the rear end of the wrapper overlapping upon the first layer of wrapper upon the paper, and pressing down the overlapping portion of the wrapper for pasting, substantially as described.
3. The combination with a core of less length than the width of the paper to be wrapped, of means for winding a paper and wrapper upon the core, and devices by which the paper and wrapper are led from the core with the rear end of the wrapper overlapping the first layer of wrapper upon the paper and the overlapping portion of the wrapper pressed down for pasting, substantially as described.
4. The combination with a core formed in two parts and adapted to support at its opposite sides the paper to be wrapped, of means for winding a paper and wrapper upon the core, and devices by which the paper and wrapper are led from the core with the rear end of the wrapper overlapping the first layer of wrapper upon the paper and the overlapping portion of the wrapper pressed down for pasting, substantially as described.
5. The combination with a rotating core of less length than the width of the paper to be wrapped, of devices co-operating with said core to secure the winding of the paper upon the core with a wrapper applied to that part of the paper not supported directly by the core, and devices by which the paper and wrapper are led from the core with the rear end of the wrapper overlapping the first layer of wrapper upon the paper and the overlapping portion of the wrapper pressed down for pasting, substantially as described.
6. The combination with a rotating core of

less length than the width of the paper to be wrapped, of feeding devices co-operating with said core to wind the paper and wrapper upon the core by friction between the feeding devices and core, and devices by which the paper and wrapper are led from the core with the rear end of the wrapper overlapping the first layer of wrapper upon the paper and the overlapping portion of the wrapper pressed down for pasting, substantially as described.

7. The combination with a rotating core of less length than the width of the paper to be wrapped and having a periphery greater than the length of the paper, of devices co-operating with the core to secure the winding of the paper and wrapper upon the core during the first rotation of the core, feeding and pressing devices by which the paper and wrapper are delivered from the core and the wrapper pressed down upon the paper for pasting, and a switch operating to guide the leading ends of the paper and wrapper about the core during the first rotation and to guide the leading ends of the paper and wrapper from the core to the feeding and pressing devices on the second rotation of the core, substantially as described.

8. The combination with a rotating core of less length than the width of the paper to be wrapped and having a periphery greater than the length of the paper, of devices co-operating with the core to secure the winding of the paper and wrapper upon the core during the first rotation of the core, feeding and pressing devices by which the paper and wrapper are delivered from the core and the wrapper pressed down upon the paper for pasting, and a switch operating to guide the leading ends of the paper and wrapper about the core during the first rotation and to guide the leading ends of the paper and wrapper from the core to the feeding and pressing devices on the second rotation of the core, and pasting mechanism for applying paste to the wrapper upon the paper during the first rotation of the core, substantially as described.

9. The combination with the two rotating cylinders C, D adapted to support at its opposite sides the paper to be wrapped and having a periphery greater than the length of the paper, of feeding devices co-operating with said cylinders to wind the paper and wrapper upon the core during the first rotation of the cylinders, delivery belts or rolls by which the papers are delivered and the wrapper pressed down for pasting, switch V operating to guide the leading ends of the paper and wrapper about the cylinders during their first rotation, and means for throwing said switch inward between the cylinders on their second rotation to guide the leading ends of

the paper and wrapper to the delivery belts, substantially as described.

10. The combination with the two rotating cylinders C, D adapted to support at its opposite sides the paper to be wrapped and having a periphery greater than the length of the paper, of feeding devices co-operating with said cylinders to wind the paper and wrapper upon the core during the first rotation of the cylinders, pasting mechanism for applying paste to the wrapper during the first rotation of the cylinders, delivery belts or rolls by which the papers are delivered and the wrapper pressed down for pasting, switch B operating to guide the leading ends of the paper and wrapper about the cylinders during their first rotation, and means for throwing said switch inward between the cylinders on the second rotation to guide the leading end of the paper and wrapper to the delivery devices, substantially as described.

11. The combination with the two rotating cylinders C, D, of the guides P between the cylinders, belts E, F co-operating with said cylinders, one or more belts N between said cylinders, belts Q, R co-operating with said cylinders on the opposite side from the belts E, F, guides U between said belts, delivery belts L co-operating with belts E, F, N to deliver the paper, switch V, and means for operating said switch to guide the leading ends of the paper and wrapper about the cylinders during their first rotation and to guide the leading ends of the paper and wrapper to the delivery belts on their second rotation, substantially as described.

12. The combination with the two rotating cylinders C, D, of the guides P between the cylinders, belts E, F co-operating with said cylinders, one or more belts N between said cylinders, belts Q, R co-operating with said cylinders on the opposite side from the belts E, F, guides U between said belts, mechanism for applying paste to the wrapper upon the paper between the guides U during the first rotation of the cylinders, delivery belts L co-operating with belts E, F, N to deliver the paper, switch V, and means for operating said switch to guide the leading ends of the paper and wrapper about the cylinders during their first rotation and to guide the leading ends of the paper and wrapper to the delivery belts on their second rotation, substantially as described.

In testimony whereof I have hereunto set my hand in the presence of two subscribing witnesses.

LUTHER C. CROWELL.

Witnesses:

J. J. KENNEDY,
C. J. SAWYER.