

No. 644,102.

Patented Feb. 27, 1900.

I. SEDGWICK.
WINDMILL OR ENGINE.

(Application filed Feb. 23, 1899.)

(No Model.)

3 Sheets—Sheet 1.

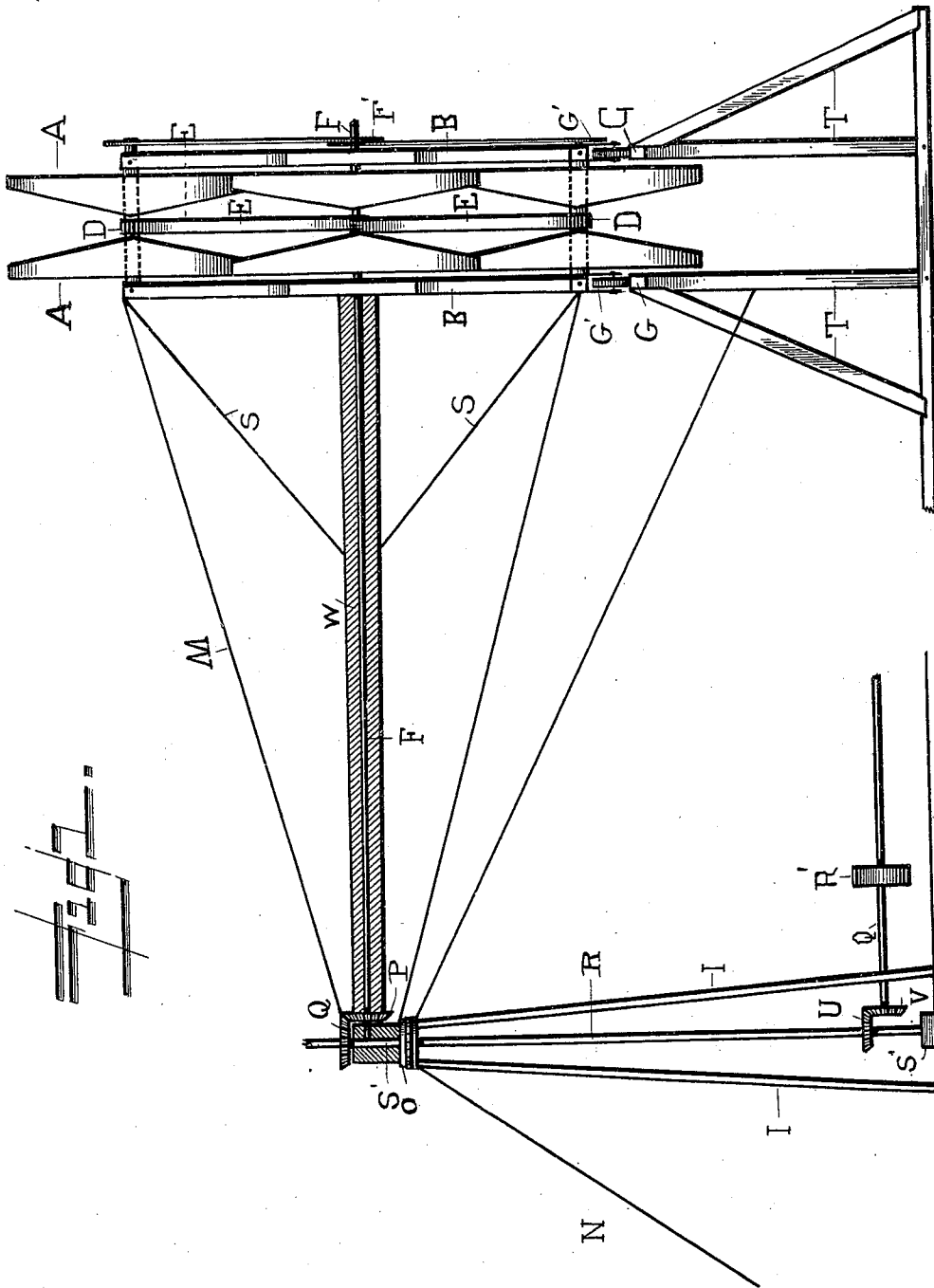

Witnesses
Chas. C. Chitry
Gust. Kant.

Isham Sedgwick Inventor
By *Robert W. Randle* Attorney.

No. 644,102.

Patented Feb. 27, 1900.

I. SEDGWICK.
WINDMILL OR ENGINE.

(No Model.)

(Application filed Feb. 23, 1899.)

3 Sheets—Sheet 2.

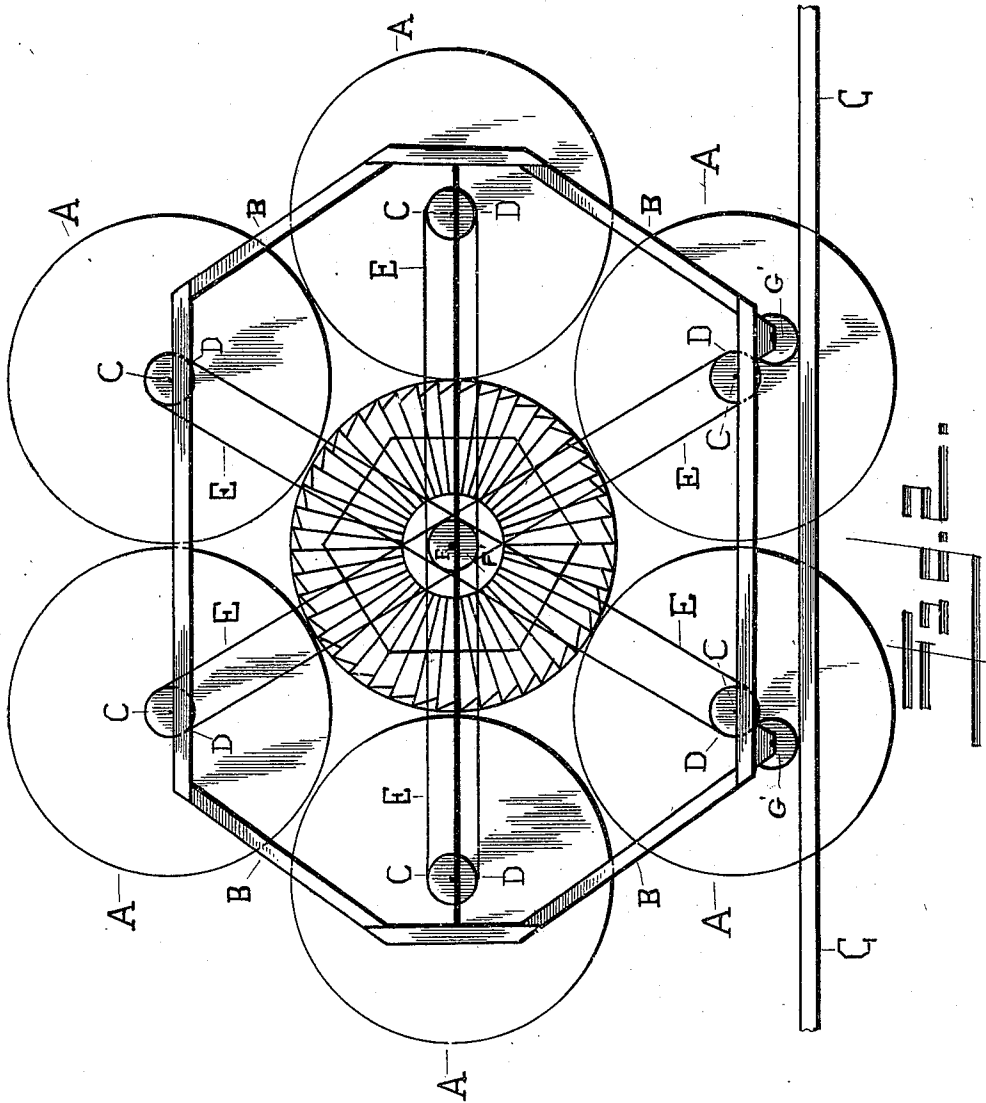

Witnesses
Chas. E. Whitney
Gust. Hunt,

Isham Sedgwick
Inventor

By *Robert W. Randle*
Attorney.

No. 644,102.

Patented Feb. 27, 1900.

I. SEDGWICK.
WINDMILL OR ENGINE.
(Application filed Feb. 23, 1899.)

(No Model.)

3 Sheets—Sheet 3.

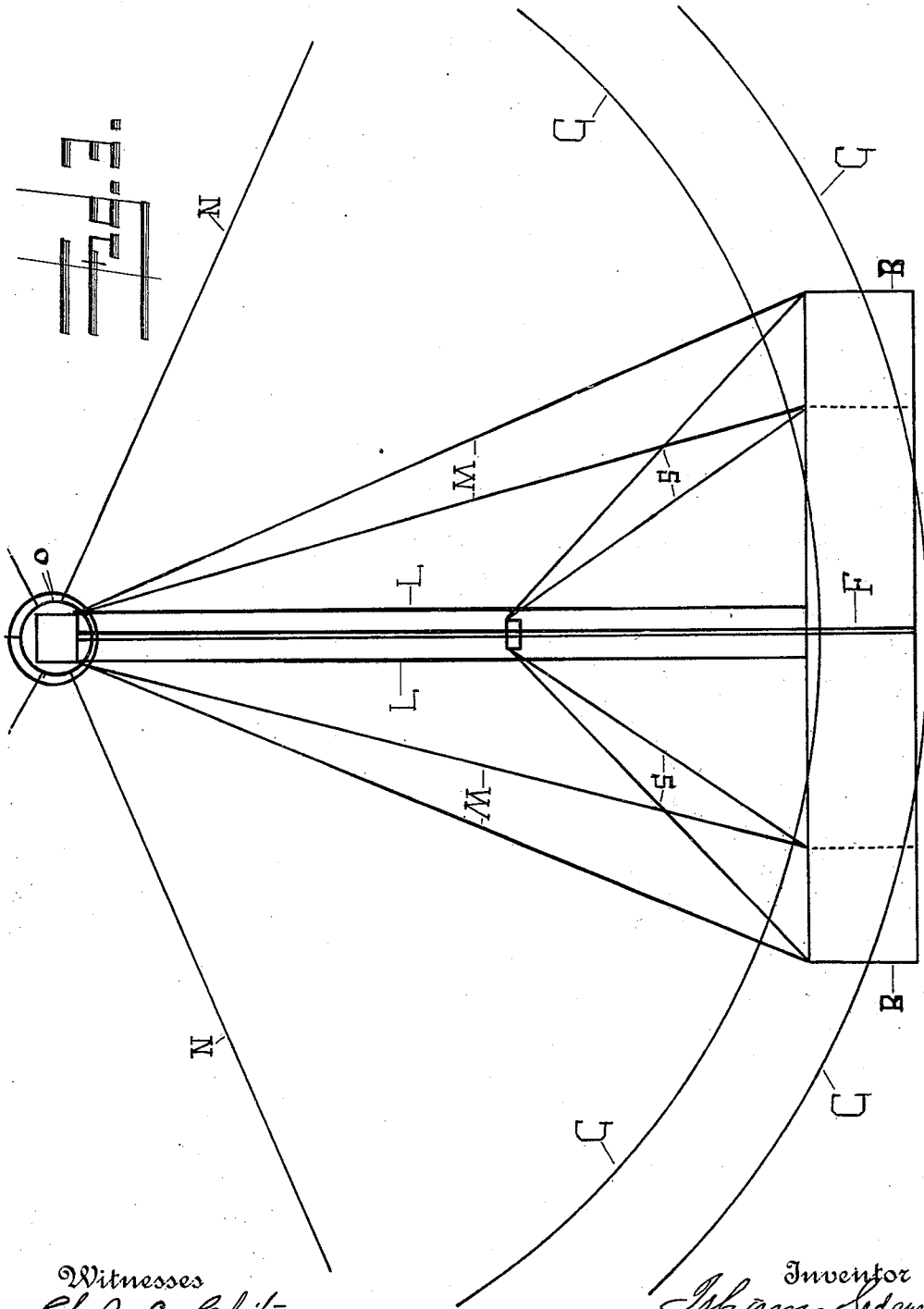

Witnesses
Chas. E. Chitry
Just. Kant.

Inventor
Isham Sedgwick.
By *Robert W. Randle*
Attorney.

UNITED STATES PATENT OFFICE.

ISHAM SEDGWICK, OF RICHMOND, INDIANA.

WIND MILL OR ENGINE.

SPECIFICATION forming part of Letters Patent No. 644,102, dated February 27, 1900.

Application filed February 23, 1899. Serial No. 706,504. (No model.)

To all whom it may concern:

Be it known that I, ISHAM SEDGWICK, a citizen of the United States, residing at Richmond, in the county of Wayne and State of Indiana, have invented certain new and useful Improvements in Wind Mills or Engines, of which the following is a specification.

My invention relates to improvements in wind mills or engines; and the main object of my invention is the provision of a mill or engine whose operating mechanism is movable in order that the wind coming from any direction may be used to operate the mechanism to operate any character of machinery.

Another object of my invention is the provision of a simple, durable, and inexpensive wind mill or engine, thus producing a very efficient and practical one.

To attain the desired objects, the invention consists of a windmill embodying novel features of construction and combination of parts, substantially as disclosed herein.

Figure 1 is a side elevation of the main parts of my improved windmill. Fig. 2 is a front plan view of the power-utilizing mechanism, and Fig. 3 is a diagrammatic top plan view of the main portion of my invention.

In the drawings, A designates the wind-driven wheels, the central one of which is mounted upon the horizontal shaft F, journaled in the central part of the framework or carriage B. Secured upon different parts of the frame and equally distributed therearound are the axles or shafts C, upon which the remainder of the wheels A are journaled. Secured upon these shafts are the sprocket or belt-attaching wheels D, around which are adapted to pass the chains or belts E to the sprocket or other wheels F' on the shaft F. Upon the lower sides of the carriage are secured the rollers G', which are adapted to allow the carriage to run upon circular tracks G, supported by the framework T.

In the center of the circle formed by the tracks is a tower I, which has secured at its top the circular rings or plates O, to which are slidably secured the brace-rods M, which have their other ends secured to the carriage-frame to hold the same in an upright position, and to hold or support the tower in an upright position I employ the brace-rods N, which are

secured near the top of the tower and to the stays of the frame T. This shaft F is journaled in the long sleeve W, supported by the brace-rods S, and near the inner end of this shaft is the bevel gear-wheel P, which meshes with the bevel gear-wheel Q upon the vertical shaft R, journaled in the bearings S' at the top and bottom of the tower, the said top bearing also forming a rotatable bearing for the extreme end of the shaft F. Upon the lower portion of the vertical shaft is another bevel gear-wheel U, which meshes with the gear-wheel V upon the shaft Q', carrying the power-transmitting wheel R', as shown in Fig. 1.

I would have it understood that any well-known means may be employed to hold the driving wind-wheels in their proper direction and also that any well-known power-transmitting means or devices may be employed without departing from the spirit of my invention. Thus it will be seen that the wind turns the wheels mounted on the movable carriage, said wheels revolving the central shaft, which in turn revolves the other mechanism to operate any character of machinery.

It is evident that I provide a windmill which is the embodiment of simplicity, durability, and cheapness, and which is therefore very practical for the intended purposes.

I claim—

1. A windmill, consisting of the central tower mounted on a suitable base, a vertical shaft journaled in said tower, rotatable bearings journaled at the top of said tower, a bevel gear-wheel carried at the top of said shaft, a long horizontal sleeve, a correspondingly-long shaft mounted in said sleeve having its inner end journaled in said bearings and having a bevel gear-wheel meshing with said gear of the vertical shaft, a framework connected to the outer end of said sleeve, a central wind-wheel and other wind-wheels arranged in a circle around and outside of said central wheel, all of said wheels being mounted in said framework, connections between said wheels and the long shaft, and means to brace and support said framework as it is swung around in any direction.

2. A windmill consisting of a central tower,

a vertical shaft mounted in said tower, a horizontal sleeve at right angles to said shaft, a framework connected to the outer end of said sleeve, a shaft connected with said vertical
5 shaft and extending through and out of said sleeve, a central wind-wheel and other wind-wheels arranged in a circle around and outside of said central wheel, all of said wheels being mounted in said framework and having

connections with said horizontal shaft, and to braces to support said sleeve and framework.

In testimony whereof I affix my signature in presence of two witnesses.

ISHAM SEDGWICK.

Witnesses:

P. W. SMITH,
C. W. FERGUSON.