

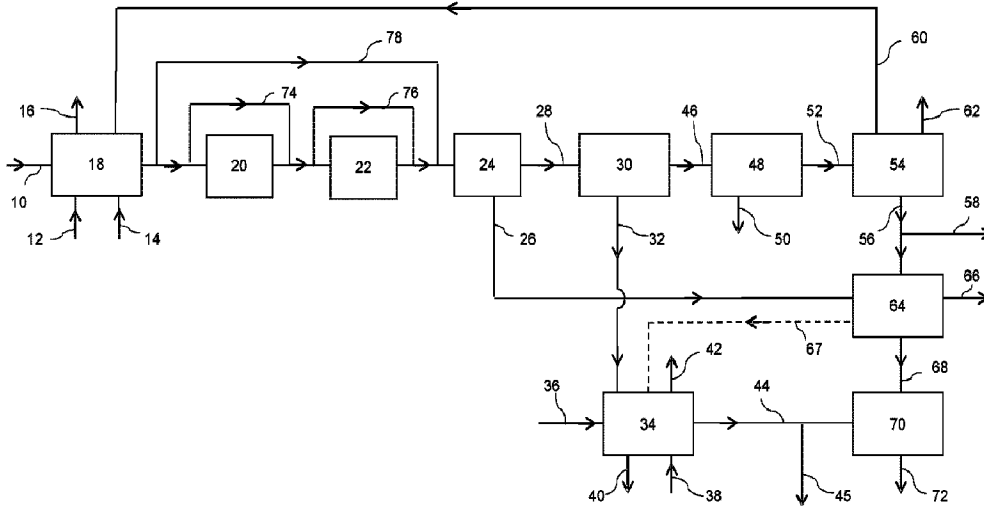

(86) Date de dépôt PCT/PCT Filing Date: 2016/11/28
 (87) Date publication PCT/PCT Publication Date: 2017/06/22
 (45) Date de délivrance/Issue Date: 2024/04/30
 (85) Entrée phase nationale/National Entry: 2018/05/24
 (86) N° demande PCT/PCT Application No.: GB 2016/053725
 (87) N° publication PCT/PCT Publication No.: 2017/103564
 (30) Priorité/Priority: 2015/12/18 (GB1522396.9)

(51) Cl.Int./Int.Cl. *C07C 273/04* (2006.01),
C07C 273/14 (2006.01)
 (72) Inventeurs/Inventors:
ERLANDSSON, OLA, SE;
MAGNUSSON, ANDREAS ERIK JOHAN, SE;
MCFARLANE, KATE, GB;
PACH, JOHN DAVID, GB;
SHELDON, DANIEL THOMAS, GB;
WARD, DARREN, GB
 (73) Propriétaire/Owner:
JOHNSON MATTHEY PUBLIC LIMITED COMPANY, GB
 (74) Agent: GOWLING WLG (CANADA) LLP

(54) Titre : PROCÉDE INTEGRE DE PRODUCTION D'UREE STABILISEE PAR DU FORMALDEHYDE
 (54) Title: INTEGRATED PROCESS FOR THE PRODUCTION OF FORMALDEHYDE-STABILISED UREA



(57) **Abrégé/Abstract:**

A process for the production of formaldehyde-stabilised urea is described comprising the steps of: (a) generating a synthesis gas comprising hydrogen, nitrogen, carbon monoxide, carbon dioxide and steam in a synthesis gas generation unit, (b) subjecting the

(57) **Abrégé(suite)/Abstract(continued):**

synthesis gas to one or more stages of water-gas shift in one or more water-gas shift reactors to form a shifted gas; (c) recovering carbon dioxide from the shifted gas in a carbon dioxide removal unit to form a carbon dioxide-depleted synthesis gas; (d) synthesising methanol from the carbon dioxide-depleted synthesis gas in a methanol synthesis unit and recovering the methanol and a methanol synthesis off-gas comprising nitrogen, hydrogen and residual carbon monoxide; (e) subjecting at least a portion of the recovered methanol to oxidation with air in a formaldehyde production unit; (f) subjecting the methanol synthesis off-gas to methanation in a methanation reactor containing a methanation catalyst to form an ammonia synthesis gas; (g) synthesising ammonia from the ammonia synthesis gas in an ammonia production unit and recovering the ammonia; (h) reacting a portion of the ammonia and at least a portion of the recovered carbon dioxide stream in a urea production unit to form a urea stream; and (i) stabilising the urea by mixing the urea stream and a stabiliser prepared using formaldehyde recovered from the formaldehyde production unit, wherein a portion of the synthesis gas generated by the synthesis gas generation unit by-passes either the one or more water-gas shift reactors; the carbon dioxide removal unit; or the one or more water-gas shift reactors and the carbon dioxide removal unit.

(12) INTERNATIONAL APPLICATION PUBLISHED UNDER THE PATENT COOPERATION TREATY (PCT)

(19) World Intellectual Property
Organization
International Bureau(10) International Publication Number
WO 2017/103564 A1(43) International Publication Date
22 June 2017 (22.06.2017)

- (51) **International Patent Classification:**
C07C 273/04 (2006.01) C07C 273/14 (2006.01)
- (21) **International Application Number:**
PCT/GB2016/053725
- (22) **International Filing Date:**
28 November 2016 (28.11.2016)
- (25) **Filing Language:** English
- (26) **Publication Language:** English
- (30) **Priority Data:**
1522396.9 18 December 2015 (18.12.2015) GB
- (71) **Applicant: JOHNSON MATTHEY PUBLIC LIMITED COMPANY** [GB/GB]; 5th Floor, 25 Farringdon Street, London EC4A 4AB (GB).
- (72) **Inventors: ERLANDSSON, Ola;** Johnson Matthey Formox AB, 28480 Perstorp (SE). **MAGNUSSON, Andreas Erik Johan;** Johnson Matthey Formox AB, 28240 Perstorp (SE). **MCFARLANE, Kate;** Johnson Matthey PLC, PO Box 1, Belasis Avenue, Billingham Cleveland TS23 1LB (GB). **PACH, John David;** Johnson Matthey PLC, PO Box 1, Belasis Avenue, Billingham Cleveland TS23 1LB (GB). **SHELDON, Daniel Thomas;** Johnson Matthey PLC, PO Box 1, Belasis Avenue, Billingham Cleveland TS23 1LB (GB). **WARD, Darren;** Johnson Matthey PLC, PO Box 1, Belasis Avenue, Billingham Cleveland TS23 1LB (GB).
- (74) **Agent: RIDLAND, John;** Johnson Matthey Process Technologies, PO Box 1, Belasis Avenue, Billingham Cleveland TS23 1LB (GB).
- (81) **Designated States** (unless otherwise indicated, for every kind of national protection available): AE, AG, AL, AM, AO, AT, AU, AZ, BA, BB, BG, BH, BN, BR, BW, BY, BZ, CA, CH, CL, CN, CO, CR, CU, CZ, DE, DJ, DK, DM, DO, DZ, EC, EE, EG, ES, FI, GB, GD, GE, GH, GM, GT, HN, HR, HU, ID, IL, IN, IR, IS, JP, KE, KG, KN, KP, KR, KW, KZ, LA, LC, LK, LR, LS, LU, LY, MA, MD, ME, MG, MK, MN, MW, MX, MY, MZ, NA, NG, NI, NO, NZ, OM, PA, PE, PG, PH, PL, PT, QA, RO, RS, RU, RW, SA, SC, SD, SE, SG, SK, SL, SM, ST, SV, SY, TH, TJ, TM, TN, TR, TT, TZ, UA, UG, US, UZ, VC, VN, ZA, ZM, ZW.
- (84) **Designated States** (unless otherwise indicated, for every kind of regional protection available): ARIPO (BW, GH, GM, KE, LR, LS, MW, MZ, NA, RW, SD, SL, ST, SZ, TZ, UG, ZM, ZW), Eurasian (AM, AZ, BY, KG, KZ, RU, TJ, TM), European (AL, AT, BE, BG, CH, CY, CZ, DE, DK, EE, ES, FI, FR, GB, GR, HR, HU, IE, IS, IT, LT, LU, LV, MC, MK, MT, NL, NO, PL, PT, RO, RS, SE, SI, SK, SM, TR), OAPI (BF, BJ, CF, CG, CI, CM, GA, GN, GQ, GW, KM, ML, MR, NE, SN, TD, TG).
- Declarations under Rule 4.17:**
— as to applicant's entitlement to apply for and be granted a patent (Rule 4.17(ii))

[Continued on next page]

(54) **Title:** INTEGRATED PROCESS FOR THE PRODUCTION OF FORMALDEHYDE-STABILISED UREA

Figure 1

(57) **Abstract:** A process for the production of formaldehyde-stabilised urea is described comprising the steps of: (a) generating a synthesis gas comprising hydrogen, nitrogen, carbon monoxide, carbon dioxide and steam in a synthesis gas generation unit, (b) subjecting the synthesis gas to one or more stages of water-gas shift in one or more water-gas shift reactors to form a shifted gas; (c) recovering carbon dioxide from the shifted gas in a carbon dioxide removal unit to form a carbon dioxide-depleted synthesis gas; (d) synthesising methanol from the carbon dioxide-depleted synthesis gas in a methanol synthesis unit and recovering the methanol and a methanol synthesis off-gas comprising nitrogen, hydrogen and residual carbon monoxide; (e) subjecting at least a portion of the recovered methanol to oxidation with air in a formaldehyde production unit; (f) subjecting the methanol synthesis off-gas to methanation in a methanation reactor containing a methanation catalyst to form an ammonia synthesis gas; (g) synthesising ammonia from the ammonia synthesis gas in an ammonia production unit and recovering the ammonia; (h) reacting a portion of the ammonia and at least a portion of the recovered carbon dioxide stream in a urea production unit to form a urea stream; and (i) stabilising the urea by mixing the urea stream and a stabiliser prepared using formaldehyde recovered from the formaldehyde production unit, wherein a portion of the synthesis gas generated by the synthesis gas generation unit by-passes either the one or more water-gas shift reactors; the carbon dioxide removal unit; or the one or more water-gas shift reactors and the carbon dioxide removal unit.

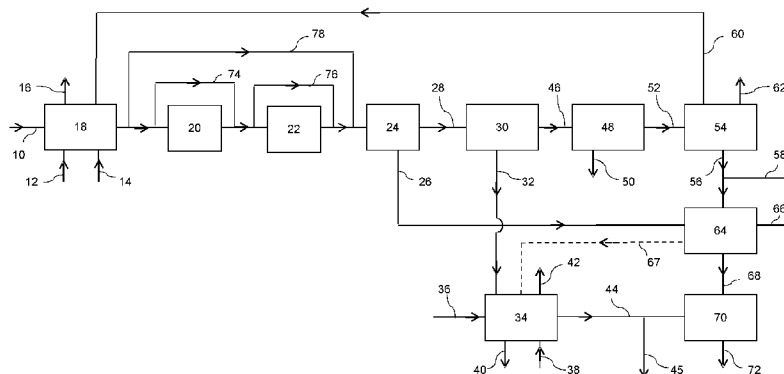

WO 2017/103564 A1

WO 2017/103564 A1 

— *of inventorship (Rule 4.17(iv))*

Published:

— *with international search report (Art. 21(3))*

INTEGRATED PROCESS FOR THE PRODUCTION OF FORMALDEHYDE-STABILISED UREA

5 The present invention relates to a process for the production of formaldehyde-stabilised urea. More particularly, it relates to an integrated process for the production of formaldehyde-stabilised urea in a process including the co-production of methanol and ammonia.

10 Urea finds widespread use as a fertiliser and in industrial chemical manufacture. It is conventionally made by reacting ammonia with carbon dioxide to form a solid product which is often shaped by prilling or granulating. Formaldehyde or a urea-formaldehyde concentrate (UFC) are often used to stabilise the urea before or during the shaping process.

15 However, the demand for formaldehyde to stabilise urea from a single production facility is small and beyond the economic feasibility for a dedicated formaldehyde stabiliser production facility. Due to the small scale of the requirements, the formaldehyde is normally produced at a separate dedicated formaldehyde stabiliser production facility and transported to the ammonia/urea production facility where it is stored.

20 We have developed an integrated urea-formaldehyde process with a dedicated formaldehyde stabiliser production unit based on a methanol-ammonia co-production process that provides improved flexibility in the amount of methanol, ammonia and urea synthesised.

25 Accordingly, the invention provides a process for the production of formaldehyde-stabilised urea comprising the steps of: (a) generating a synthesis gas comprising hydrogen, nitrogen, carbon monoxide, carbon dioxide and steam in a synthesis gas generation unit, (b) subjecting the synthesis gas to one or more stages of water-gas shift in one or more water-gas shift reactors to form a shifted gas; (c) recovering carbon dioxide from the shifted gas in a carbon dioxide removal unit to form a carbon dioxide-depleted synthesis gas; (d) synthesising methanol from the carbon dioxide-depleted synthesis gas in a methanol synthesis unit and recovering the methanol and a methanol synthesis off-gas comprising
30 nitrogen, hydrogen and residual carbon monoxide; (e) subjecting at least a portion of the recovered methanol to oxidation with air in a formaldehyde production unit; (f) subjecting the methanol synthesis off-gas to methanation in a methanation reactor containing a methanation catalyst to form an ammonia synthesis gas; (g) synthesising ammonia from the ammonia synthesis gas in an ammonia production unit and recovering the ammonia; (h) reacting a portion of the ammonia and at least a portion of the
35 recovered carbon dioxide stream in a urea production unit to form a urea stream; and (i) stabilising the urea by mixing the urea stream and a stabiliser prepared using formaldehyde recovered from the formaldehyde production unit,

wherein a portion of the synthesis gas generated by the synthesis gas generation unit by-passes either the one or more water-gas shift reactors; the carbon dioxide removal unit; or the one or more water-gas shift reactors and the carbon dioxide removal unit.

5

Accordingly, the invention provides a process for producing formaldehyde-stabilised urea comprising the steps of:

(A) generating a synthesis gas comprising hydrogen, nitrogen, carbon monoxide, carbon dioxide and steam in a synthesis gas generation unit;

10

(B) subjecting the synthesis gas to one or more stages of water-gas shift in one or more water-gas shift reactors to form a shifted gas;

(C) recovering carbon dioxide from the shifted gas in a carbon dioxide removal unit to form a carbon dioxide-depleted synthesis gas;

15

(D) passing the carbon dioxide-depleted synthesis gas through a methanol synthesis unit to synthesize a crude methanol and recovering the crude methanol and a methanol synthesis off-gas stream comprising nitrogen, hydrogen and residual carbon monoxide;

(E) oxidizing at least a portion of the recovered crude methanol with air in a formaldehyde production unit to produce an oxidised gas containing formaldehyde and a formaldehyde vent gas, the crude methanol having been adjusted to have a water content in a range of from 5 wt% to 20 wt%;

20

(F) methanating the methanol synthesis off-gas in a methanation reactor containing a methanation catalyst to form an ammonia synthesis gas;

(G) synthesising ammonia from the ammonia synthesis gas in an ammonia production unit and recovering the ammonia;

25

(H) reacting a portion of the ammonia and at least a portion of the recovered carbon dioxide in a urea production unit to form a urea stream; and

(I) stabilising the urea by mixing the urea stream and a stabiliser prepared using formaldehyde recovered from the formaldehyde production unit, wherein:

30

(i) a portion of the synthesis gas generated by the synthesis gas generation unit by-passes

(a) one or more water-gas shift reactors; or

(b) one or more water-gas shift reactors and the carbon dioxide removal unit; or

(ii) a portion of the shifted gas by-passes the carbon dioxide removal unit; and

wherein the crude methanol recovered from step (D) is fed to oxidizing step (E).

35

There have been numerous designs for ammonia and methanol co-production over the last 50 years or so, but they have generally focussed on generating large quantities of both materials as saleable products. Examples of such processes are described, for example in US6106793, US6333014, US7521483, US8247463, US8303923, and WO2013/102589.

5 None of these processes include a dedicated formaldehyde production unit as claimed.

In the claimed process, a portion of the synthesis gas generated by the synthesis gas generation unit by-passes either the one or more water-gas shift reactors; the carbon dioxide removal unit; or the one or more water-gas shift reactors and the carbon dioxide removal unit.

10 The streams by-passing the one or more water-gas shift reactors are combined with the shifted gas stream fed to the carbon dioxide removal unit. The streams by-passing the carbon dioxide removal unit are combined with the carbon-dioxide depleted gas stream fed to the methanol synthesis unit. Streams that bypass the carbon dioxide removal unit are desirably treated to remove water therefrom to lessen the amount of water in the crude
15 methanol and improve the rate of the methanol synthesis reaction. The by-pass streams allow the levels of carbon monoxide and/or carbon dioxide to the methanol synthesis unit to be controlled thereby increasing the flexibility in the amount of methanol, ammonia and urea synthesised.

20 In addition, the methanol synthesis reactions may be depicted as follows:

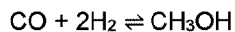

25 From these reactions, it can be seen that carbon dioxide makes water as a by-product in the methanol synthesis whereas carbon monoxide does not. If the major carbon oxide source for the methanol synthesis reaction is carbon monoxide, less water will be formed in the reaction which has the added advantage that the crude methanol need not be subjected to a distillation step before being used as feed to the formaldehyde plant, which offers
30 considerable savings in capital and operating costs. If the carbon-dioxide removal stage is by-passed and hence the proportion of the carbon dioxide in the methanol synthesis feed gas is higher, more water is produced but the methanol synthesis reactor may be smaller.

In the process, the methanol converter for the formaldehyde production is placed between the
35 carbon dioxide removal and methanation stages of the ammonia/urea plant, where carbon oxide levels are low, preventing excessive hydrogen consumption. There is still a need for a methanator because, to maintain a reasonable sized methanol converter, the approach to equilibrium is kept relatively high.

Other possible placements of the methanol converter are upstream of the high temperature shift converter and immediately upstream of the synthesis loop. In the first case, the temperatures are too high for methanol synthesis and the high levels of all reactants makes over-conversion possible, with associated wastage of hydrogen. In the latter case, the methanol synthesis would need to run at ammonia synthesis pressure (>130 bar) which requires non-conventional, and more expensive, methanol synthesis apparatus.

Should methanol reach the methanation unit, it will conveniently be converted into carbon oxides and water. The carbon oxides will then be methanated as normal. This process would generate a small endotherm to compete against the exothermic methanation. An additional benefit of this scheme is clear when considering the two sets of reactions;



Any methanol synthesis that occurs saves one mole of hydrogen per mole of methanol produced (assuming equivalent consumption of carbon monoxide and dioxide), enabling increased ammonia production, estimated to be approximately an additional third of a percent, equivalent to about 7 mtpd on a 2,000 mtpd ammonia plant.

The synthesis gas, comprising carbon monoxide, carbon dioxide, hydrogen and nitrogen provided in step (a) may be formed by any suitable means. Different synthesis gas generation units can provide synthesis gases with different carbon monoxide: carbon dioxide ratios. The process allows the product mix to be adjusted for a wide range of synthesis gas compositions. The synthesis gas generation may be based on primary steam reforming of a hydrocarbon such as natural gas, naphtha or a refinery off-gas and secondary reforming with air or oxygen-enriched air; or by the gasification of a carbonaceous feedstock, such as coal or biomass with air. Preferably the synthesis gas generation stage comprises steam reforming a hydrocarbon. This may be achieved by primary reforming a hydrocarbon with steam in externally-heated catalyst-filled tubes in a fired- and/or gas-heated steam reformer and secondary reforming the primary-reformed gas mixture in an autothermal or secondary reformer by subjecting it to partial combustion with air, or air enriched in oxygen, and then passing the partially combusted gas mixture through a bed of steam reforming catalyst. A heat exchange reformer, such as a gas-heated steam reformer (GHR), may be operated in parallel with a conventional fired reformer or in series with a conventional fired reformer and the product gas fed to a common secondary reformer. By-passing a portion of the hydrocarbon feedstock around a primary reformer may be used to reduce the carbon monoxide: carbon dioxide ratio in the synthesis gas. If desired one or more stages of

adiabatic pre-reforming may also be performed before the fired reformer and/or heat exchange reformer.

5 The primary reforming catalyst typically comprises nickel at levels in the range 5-30% wt, supported on shaped refractory oxides, such as alpha alumina, magnesium aluminate or calcium aluminate. If desired, catalysts with different nickel contents may be used in different parts of the tubes, for example catalysts with nickel contents in the range 5-15% wt or 30-85% wt may be used advantageously at inlet or exit portions of the tubes. Alternatively, structured catalysts, wherein a nickel or precious metal catalyst is provided as a coated layer on a
10 formed metal or ceramic structure may be used, or the catalysts may be provided in a plurality of containers disposed within the tubes. In a fired steam reformer, steam reforming reactions take place in the tubes over the steam reforming catalyst at temperatures above 350°C and typically the process fluid exiting the tubes is at a temperature in the range 650-950°C. The combusting gases flowing around the outside of the tubes may have a temperature in the
15 range 900-1300°C. In a GHR, the catalyst may again be at temperatures above 350°C with the process fluid exiting the tubes at a temperature in the range 500—950°C. Here, the heat exchange medium flowing around the outside of the tubes may have a temperature in the range 500-1200°C. The pressure may be in the range 10-80 bar abs. In a secondary reformer, the primary-reformed gas is partially combusted often in a burner apparatus
20 mounted usually near the top of the reformer. The partially combusted reformed gas is then passed adiabatically through a bed of a steam reforming catalyst usually disposed below the burner apparatus, to bring the gas composition towards equilibrium. Heat for the endothermic steam reforming reaction is supplied by the hot, partially combusted reformed gas. As the partially combusted reformed gas contacts the steam reforming catalyst it is cooled by the
25 endothermic steam reforming reaction to temperatures in the range 900-1100°C. The bed of steam reforming catalyst in the secondary reformer typically comprises nickel at levels in the range 5-30% wt, supported on shaped refractory oxides, but layered beds may be used wherein the uppermost catalyst layer comprises a precious metal, such as platinum or rhodium, on a zirconia support. Such steam reforming apparatus and catalysts are
30 commercially available.

Alternatively, the steam reforming may be achieved by passing a mixture of the hydrocarbon and steam through an adiabatic pre-reformer containing a bed of steam reforming catalyst and then passing the pre-reformed gas mixture and air to an autothermal reformer which
35 operates in the same way as the secondary reformer to produce a gas stream containing hydrogen, carbon oxides and steam. In adiabatic pre-reforming, a mixture of hydrocarbon and steam, typically at a steam to carbon ratio in the range 1-4, is passed at an inlet temperature in the range 300-620°C to a fixed bed of pelleted nickel-containing pre-reforming catalyst. Such catalysts typically comprise $\geq 40\%$ wt nickel (expressed as NiO) and may be
40 prepared by co-precipitation of a nickel-containing material with alumina and promoter

compounds such as silica and magnesia. Again, the pressure may be in the range 10-80 bar abs.

5 Alternatively, the reaction stream may be formed by gasification of coal, biomass or other carbonaceous material with air using gasification apparatus. In such processes the coal, biomass or other carbonaceous material is heated to high temperatures in the absence of a catalyst to form a crude synthesis gas often containing sulphur contaminants such as hydrogen sulphide, which have to be removed. Gasification of carbonaceous feedstock to produce a synthesis gas may be achieved using known fixed bed, fluidised-bed or entrained-
10 flow gasifiers at temperatures in the range 900-1700°C and pressures up to 90 bar abs. The crude synthesis gas streams require additional treatments known in the art to remove unwanted sulphur and other contaminants.

15 In a preferred process, the synthesis gas generation stage comprises primary reforming a hydrocarbon, particularly natural gas, in a fired steam reformer to produce a gas stream comprising hydrogen, carbon monoxide, carbon dioxide and steam, and secondary reforming in which the primary reformed gas is further reformed in a secondary reformer using air or oxygen-enriched air to provide a synthesis gas stream comprising hydrogen, carbon oxides and nitrogen.

20 If desired, one air feed may be provided for both the production of the synthesis gas and the production of the formaldehyde. This offers benefits in the reduction of capital and operating costs when compared to that required for the separate systems utilised in the prior art. In generating synthesis gas on ammonia plants, multiple stages of compression are often used.
25 The air for the methanol oxidation may therefore conveniently be taken after the first stage and before the final stage of air compression. This air source therefore removes the need for a separate air compression unit for the formaldehyde production unit. Thus in one embodiment, a single source of air is compressed, divided into first and second portions, the first portion provided to a formaldehyde production unit and the second portion further
30 compressed and provided to a synthesis gas generation unit. The first portion of compressed air provided to the formaldehyde production unit is used to oxidise at least a portion of the methanol. The first portion may be compressed to a pressure in the range 1.1-5 bar abs. The second portion of compressed air fed to the synthesis gas generation unit is used to generate the synthesis gas, for example in a secondary or autothermal reformer. The second
35 portion may be compressed to 10-80 bar abs. If desired, the second portion may also be preheated. The amount of air in the second portion may also be varied to control the eventual hydrogen:nitrogen ratio in the ammonia synthesis gas. The proportion of compressed air fed to the formaldehyde production unit may be up to about 20% by volume, preferably in the range 1.5-15% by volume, of the total air fed to the process.

40

Before recovery of the carbon dioxide, the crude synthesis gas is subjected in step (b) to one or more stages of water-gas shift to produce a shifted synthesis gas with the desired gas composition. In a water-gas shift stage, a portion of the carbon monoxide in the stream is converted to carbon dioxide. Any suitable catalytic shift conversion reactor and catalyst may be used. If insufficient steam is present, steam may be added to the gas stream before it is subjected to the water-gas shift conversion. The reaction may be depicted as follows;

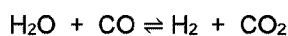

The reaction may be carried out in one or more stages. The, or each, stage may be the same or different and may be selected from high temperature shift, low temperature shift, medium temperature shift, isothermal shift and sour shift, and is preferably selected from a single stage of high temperature shift, a combination of high temperature shift and low temperature shift, a single stage of medium temperature shift, or a combination of medium temperature shift and low temperature shift.

High temperature shift catalysts may be promoted iron catalysts such as chromia- or alumina-promoted magnetite catalysts. Other high temperature shift catalysts may be used, for example iron/copper/zinc oxide/alumina catalysts, manganese/zinc oxide catalysts or zinc oxide/alumina catalysts. Medium, low temperature and isothermal shift catalysts typically comprise copper, and useful catalysts may comprise varying amounts of copper, zinc oxide and alumina. Alternatively, where sulphur compounds are present in the gas mixture, such as synthesis gas streams obtained by gasification, so-called sour shift catalysts, such as those comprising sulphides of molybdenum and cobalt, are preferred. Such water-gas shift apparatus and catalysts are commercially available.

For high temperature shift catalysts, the temperature in the shift converter may be in the range 300-460°C or 300-360°C, for medium temperature shift catalysts the temperature may be in the range 190-300°C and for low-temperature shift catalysts the temperature may be 185-270°C. The water-gas shift reaction is exothermic and so cooling may therefore be necessary between the stages. For sour shift catalysts the temperature may be in the range 200-370°C. The flow-rate of synthesis gas containing steam may be such that the gas hourly space velocity (GHSV) through the bed of water-gas shift catalyst in the reactor may be $\geq 6000 \text{ hour}^{-1}$. The pressure may be in the range 10-80 bar abs.

In a preferred embodiment, the water-gas shift stage comprises a high temperature shift stage or a medium temperature shift stage or an isothermal shift stage with or without a low temperature shift stage.

The portion of the synthesis gas produced by the synthesis gas generation unit may by-pass one or more of the water-gas shift stages, each stage comprising one or more water-gas shift reactors. Thus the portion of the synthesis gas may by-pass a high temperature shift reactor, a low temperature shift reactor, a medium temperature shift reactor, which may be an isothermal medium temperature shift reactor containing a bed of cooled medium-temperature water gas shift catalyst, or any combination of these. In a preferred embodiment where the shift stage consists of a high temperature shift reactor and a low temperature shift reactor, the portion of the synthesis gas may by-pass either the high temperature shift reactor, the low temperature shift reactor or both the high temperature shift reactor and the low temperature shift reactor. A by-pass around just the low temperature shift reactor is preferred because it produces a crude methanol stream with lower levels of water.

The amount of the by-pass streams around the water-gas shift reactors may be adjusted depending on the synthesis gas composition and the desired carbon monoxide/carbon dioxide content of the gas stream fed to the methanol synthesis stage. For example, a by-pass around a high temperature shift converter will likely be high in carbon monoxide and relatively lower in carbon dioxide. The carbon monoxide concentration of the by-pass stream around the high temperature shift in such a case may be in the range of 10-15 vol% on a dry basis and the carbon dioxide concentration may be in the range of 5-10 vol% on a dry basis. A high temperature shift reactor converts the bulk of the carbon monoxide in the synthesis gas to carbon dioxide; hence the inlet composition of a downstream water-gas shift reactor, such as a low temperature shift reactor, will be lower in carbon monoxide and higher in carbon dioxide. The carbon monoxide concentration inlet the downstream shift reactor may be in the range of 2-5 vol% on a dry basis and the carbon dioxide concentration may be in the range of 13-17 vol% on a dry basis. The downstream shift reactor converts still more carbon monoxide to carbon dioxide, and a shifted gas stream, e.g. from a low temperature shift reactor, may contain 0.1-0.5 vol% carbon monoxide on a dry basis and 15-20 vol% carbon dioxide on a dry basis.

One aspect of this invention is to co-produce a relatively small amount of methanol for the purpose of making formaldehyde to stabilise urea produced from ammonia obtained from one or more ammonia plants. Therefore, a relatively small concentration of carbon oxides may be sufficient to produce the required amount of methanol.

The amount of gas that is by-passed around each unit is dependent on the required methanol production rate and the composition of the by-pass stream. The higher the production rate of methanol, the higher the required by-pass flow rates around one or more of the water-gas shift reactors.

The unshifted synthesis gas is rich in carbon monoxide compared to the shifted synthesis gas, therefore the proportion of by-pass of unshifted gas will be smaller. The carbon dioxide content of the synthesis gas does not affect the proportion of by-pass when the by-pass stream is re-combined with a shifted synthesis gas stream upstream of the carbon dioxide removal unit. In a preferred embodiment where a by-pass stream of a partially shifted gas from a high or medium temperature shift reactor is taken around a downstream low temperature shift reactor, the by-pass flow rate around the low temperature shift reactor may be in the range of 1-70% of the partially shifted gas or synthesis gas flow rate. Where there is a by-pass around all of the water-gas shift reactor(s), as the concentration of carbon monoxide is higher, the proportion that is by-passed will be smaller. The by-pass flow rate in such cases may be in the range of 1-25% of the unshifted synthesis gas flow rate.

Where carbon dioxide constitutes a significant proportion of the shifted or unshifted synthesis gas, a by-pass around the carbon dioxide removal unit, or all or part of the water-gas shift section and the carbon dioxide removal unit, will be a smaller proportion of the total process gas flow, compared to a by-pass around all or part of the water-gas shift section only. If a by-pass stream is taken around a low temperature shift reactor and the carbon dioxide removal unit, the by-pass flow rate may be in the range of 1-20% of the total process gas flow. Similarly, if a by-pass stream is taken around all of the water-gas shift section and the carbon dioxide removal unit, the by-pass flow rate may be in the range of 1-15% of the unshifted synthesis gas flow rate.

It should be understood that in the process, the total concentration of carbon oxides (on a wet basis) is the same but the ratio of carbon monoxide to carbon dioxide will change.

Steam present in the shifted gas mixture may be condensed by cooling the shifted gas to below the dew point using one or more heat exchangers fed, for example, with cooling water. The resulting dried shifted gas may be passed to the carbon dioxide removal unit. The condensate recovered may, if desired, be fed to a condensate stripping unit or, if desired be fed to steam generators that produce steam for the synthesis gas generation and/or water-gas shift stages.

A carbon dioxide removal unit is used to recover carbon dioxide from the shifted synthesis gas in step (c). It is located downstream of a water-gas shift stage, and upstream of the methanol synthesis stage. Any suitable carbon dioxide removal unit may be used. Suitable removal units may function by reactive or chemical absorption, such as those known as aMDEA™ or Benfield™ units that are based on using regenerable amine or potassium carbonate washes, or by physical absorption, based on using methanol, glycol or another liquid at low temperature, such as Rectisol™, Selexol™ units. Carbon dioxide removal may also be performed by means of pressure-swing adsorption (PSA) using suitable solid

adsorbent materials. Such carbon dioxide removal apparatus and materials are commercially available. Some or all of the carbon dioxide formed in the synthesis gas may be removed to produce a gas stream comprising mainly hydrogen and nitrogen with low levels of carbon monoxide and/or carbon dioxide. The carbon dioxide removed by the carbon dioxide removal unit may be captured, treated to remove contaminants such as hydrogen, and stored or used for reaction downstream with the ammonia produced to form urea.

The portion of the synthesis gas produced by the synthesis gas generation unit may by-pass the carbon dioxide removal unit. The portion of the synthesis gas by-passing the carbon dioxide removal unit may also by-pass one or more of the upstream water-gas shift reactors or, there may be no by-pass of the water gas shift stage, such that a portion of a shifted gas is by-passed around the carbon dioxide removal unit. In a preferred embodiment, a by-pass stream of partially shifted gas from a high temperature shift stage or a medium temperature shift stage is taken around a low temperature shift reactor and the carbon dioxide removal unit.

As an alternative to a by-pass around the carbon dioxide removal unit, the operating conditions and effectiveness of the carbon dioxide removal unit may be adjusted so that the carbon dioxide is only partially removed from the feed gas. Thus the carbon dioxide concentration in the carbon dioxide-depleted gas stream fed to the methanol synthesis unit may be controlled by manipulation of process variables within the carbon dioxide removal unit. A by-pass stream around one or more of the water gas shift reactors may be used in combination with such manipulation to provide the desired gas composition for the downstream processes.

It is desirable to remove water from the carbon dioxide-depleted synthesis gas. Water removal, or drying, is desirable to protect the downstream methanol synthesis catalyst, improve the rate of the methanol synthesis reaction and to minimise water in the crude methanol product. Water removal may also improve the performance and reliability of the first stage of compression. Water removal may be accomplished by cooling the water-containing gas below the dew point using one or more stages of heat exchange and passing the resulting stream through a gas liquid separator. Further stages of drying, e.g. with a desiccant may be performed if desired.

Methanol is synthesised from the carbon dioxide-depleted synthesis gas in step (d). The synthesis reactions may be depicted as follows:

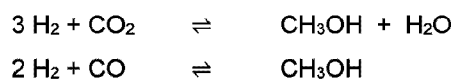

Any methanol production technology may be used. Methanol is synthesised in a synthesis unit, which may comprise a methanol converter containing a methanol synthesis catalyst. The process can be operated on a once-through basis, or on a recycle basis in which unreacted product gas, after optional methanol condensate removal, is mixed with make-up gas comprising hydrogen and carbon oxides in the desired ratio and returned to the methanol reactor. The methanol synthesis, because it is exothermic, may involve cooling by indirect heat exchange surfaces in contact with the reacting gas, or by subdividing the catalyst bed and cooling the gas between the beds by injection of cooler gas or by indirect heat exchange.

A crude methanol product comprising methanol, water and trace amounts of impurities such as ethanol may be recovered by cooling of the product gas stream to below the dew point, e.g. with cooling water. If desired, liquid ammonia may be used in a further cooling stage. Alternatively, or in addition, methanol may be recovered by scrubbing the product gas with water.

Any methanol synthesis catalyst may be used, but preferably it is based on a promoted or unpromoted copper/zinc oxide/alumina composition, for example those having a copper content in the range 50-70% wt. Promoters include oxides of Mg, Cr, Mn, V, Ti, Zr, Ta, Mo, W, Si and rare earths. In the catalyst, the zinc oxide content may be in the range 20-90% wt, preferably 20-50% wt, and the one or more oxidic promoter compounds, if present, may be present in an amount in the range 0.01-10% wt. Magnesium compounds are preferred promoters and the catalyst preferably contains magnesium in an amount 1 - 5% wt, expressed as MgO. The synthesis gas may be passed over the catalyst at a temperature in the range 200-320°C, and at a pressure in the range 20-250 bar abs, preferably 20-120 bar abs, and a space velocity in the range 500-20000 h⁻¹. Because the aim of the process is not to maximise methanol production, the inlet temperature of the methanol synthesis stage may be lower, e.g. 200-270°C thus extending the catalyst lifetime by reducing sintering of the active copper sites.

In the present process, a single stage of methanol synthesis is sufficient. Nevertheless, if desired, the methanol synthesis may be part of a multiple stage synthesis process where the product gas, with or without condensate removal, is fed to one or more further methanol synthesis reactors, which may contain the same or different methanol synthesis catalyst. Such methanol production apparatus and catalysts are commercially available. A purge gas stream may be removed to prevent the undesirable build-up of inert/unreactive gases. If desired methanol may also be synthesised from this purge gas, or hydrogen recovered from it to adjust the stoichiometry of the feed gas or to generate power.

The crude methanol recovered from the methanol synthesis unit contains water and other impurities that are often separated from the product methanol by one or more stages of distillation. In the present process, preferably all of the recovered methanol is oxidised to

produce formaldehyde. The formaldehyde production unit may use purified methanol as the feed or crude methanol as the feed. By "crude methanol" we include the liquid product of the methanol synthesis reactor after separation from the gas stream and a liquid methanol product in which the water content of the methanol has been adjusted to the range 5-20% by weight. When using crude methanol, the water content is desirably ≤ 20 %wt so that the formaldehyde stabiliser products are produced efficiently at suitable concentrations. This makes it possible to send crude methanol directly to the formaldehyde plant without the need for multiple distillation steps. Achieving low water content by controlling the reactor inlet gas composition using the appropriate by-pass would save both capital cost on distillation columns and associated equipment, as well as the operating cost of this equipment, resulting in a significant benefit.

The crude methanol may be sent for storage in a suitable storage tank. Alternatively, the crude methanol may be subjected to one or more purification stages, including a de-gassing stage, in a methanol purification unit prior to feeding it to the oxidation reactor. The de-gassing stage or any distillation stages may be provided by distillation columns heated using heat recovered from the oxidation reactor or elsewhere in the process. In particular, the degassing stage may be heated using steam generated by the oxidation stage. This simplification of the purification offers significant savings in capital and operating costs for the process.

Optionally, a water scrubber may be employed to improve recovery of the synthesised methanol from the unreacted gas after bulk separation. Recovering the methanol will improve the efficiency of the plant and will reduce the duty on the methanator. The wash water containing methanol recovered from the water scrubber may be blended with the crude methanol or may be sent to steam generators used to provide steam for the synthesis gas generation and/or the water-gas shift stages.

The unreacted gas stream recovered from the methanol synthesis unit after separation of the crude methanol stream is the methanol synthesis off-gas. It comprises nitrogen, hydrogen, and small amounts of methane, argon, carbon monoxide and carbon dioxide.

Methanol is oxidised to formaldehyde in step (e). Any formaldehyde production technology using air as the oxidant may be used. The formaldehyde is synthesised in a formaldehyde production unit, which may comprise an oxidation reactor containing an oxidation catalyst. The oxidation catalyst may be provided as a fixed bed or within externally-cooled tubes disposed within the reactor. A compressed air source, which may be from the single source as described above, is used in the formaldehyde production unit. The air may be in the temperature range 10-50°C. The air and methanol may be passed to the reactor containing an oxidation catalyst in which the methanol is oxidised. Air is preferably provided at 1.1-5 bar

abs, e.g. from a first stage of compression of the air fed to the process. The amount of air fed to the formaldehyde production unit is a relatively small proportion of the air fed to the overall process and so compression costs are not significantly increased and may be more than compensated for by the removal of additional compression equipment.

5

Production of formaldehyde from methanol and oxygen may be performed either in a silver- or a metal oxide catalysed process operated at methanol-rich or methanol-lean conditions, respectively. Hence the oxidation catalyst may be selected from either a silver catalyst or a metal oxide catalyst, preferably comprising a mixture of iron and molybdenum oxides.

10 Vanadium oxide catalysts may also be used. In the metal oxide process, the principal reaction is the oxidation of the methanol to formaldehyde;

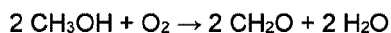

15 Over silver catalysts, in addition to the above oxidation reaction, methanol is also dehydrogenated in the principal reaction for this type of catalyst;

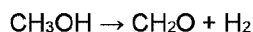

20 In the metal oxide process, formaldehyde is produced in multi-tube reactors. Typically, a reactor comprises 10-30,000 tubes containing catalyst pellets or extrudates and cooled by oil or by molten salts as heat transfer fluid. Since the reaction is highly exothermic ($\Delta H = -156$ kJ/mol), isothermal conditions are difficult to obtain and consequently a hotspot may be formed within the reaction zone. In order to limit the hot spot temperature, at the first part of
25 the reactor the catalyst can be diluted with inert pellets or extrudates. The catalyst used in the oxide process is preferably a mixture of iron molybdate $\text{Fe}_2(\text{MoO}_4)_3$ and molybdenum trioxide MoO_3 with a Mo:Fe atomic ratio between 2 and 3. The plant yield is high (88-94%) and neither molybdenum nor iron are toxic, which is favourable considering both environmental and human health aspects.

30

Air is preferably used at levels to maintain the oxygen content at the inlet of the reactor below the explosive limit. The feed gas may therefore comprise ≤ 6.5 vol% methanol for a once-through reactor or about 8-11 vol% methanol where there is recirculation. The oxidation reactor may be operated adiabatically or isothermally, where the heat of reaction can be used
35 to generate steam. The inlet temperature to the oxidation reactor is typically in the range 80-270°C, with iron-based catalytic processes operating up to 400 °C and silver-based processes up to 650°C.

40 A single passage through the oxidation reactor can result in high yields of formaldehyde, or if desired it is possible to recycle unreacted gases, which comprise mainly of nitrogen, to the

reactor inlet to maintain a low oxygen concentration. Due to the scale required in the present process, preferably the formaldehyde production stage is operated without recycle of oxidised gas to the inlet of the oxidation reactor as this removes the need for a recycle compressor and hence offers further savings.

5

An absorption tower may be used to extract the formaldehyde product from the oxidised gas mixture into either water to produce aqueous formaldehyde solution, or a urea solution to produce a urea-formaldehyde concentrate (UFC). The absorption tower may contain a selection of packing, trays and other features to promote the absorption, and cooling water may be used to provide the product at a temperature in the range 20-100°C. The absorption stage typically runs at a slightly lower pressure than the reactor.

10

In the present process, products made from the formaldehyde are used to stabilise urea. The formaldehyde production unit may be used to produce an aqueous formaldehyde solution (formalin) or a urea-formaldehyde concentrate (UFC). Urea formaldehyde concentrate that may be used typically comprises a mixture of about 60 % wt formaldehyde, about 25 % wt urea and the balance about 15% water. Such a product may be termed "UFC85". Other UFC products may also be used, e.g. UFC80. Other formaldehyde products may also be produced. Excess formaldehyde products may be recovered and sold.

15

20

The formaldehyde production unit generates a vent gas which may be passed to a vent gas treatment unit such as an emission control unit or emission control system (ECS) and discharged to atmosphere. An emission control unit or system may comprise a catalytic combustor that reacts any carbon monoxide, methanol, formaldehyde and dimethyl ether in the vent gas with oxygen. The gas emitted from an ECS, i.e. an ECS effluent, may comprise carbon dioxide, steam and nitrogen and therefore may be recycled, preferably after suitable compression, to one or more stages of the process. Thus the ECS effluent may be passed to the carbon dioxide-removal stage where steam and carbon dioxide may be recovered, to provide additional nitrogen in the synthesis gas. Alternatively the ECS effluent may be provided to the methanol synthesis stage where the carbon dioxide may be reacted with hydrogen in the synthesis gas to produce additional methanol. Alternatively, the ECS effluent may be fed to the urea production unit to provide carbon dioxide for additional urea production.

25

30

35

In another embodiment, the vent gas treatment unit comprises a gas-liquid separator that separates the nitrogen-rich off-gas from liquid methanol, which may be recycled to the oxidation reactor directly or after one or more stages of purification. The nitrogen-rich gas separated in the separator may be compressed and passed to the ammonia synthesis stage.

Alternatively the formaldehyde vent gas may be recycled directly to the process, i.e. the vent gas treatment unit or system may be omitted. In one embodiment, the formaldehyde vent gas is recycled directly to the synthesis gas generation unit as a fuel gas so that the organic contaminants present in the vent gas may be combusted to generate energy. The
5 formaldehyde vent gas may, for example, be recycled directly to the fuel gas stream of a primary reformer or may be fed to a furnace for steam generation. In this way an ECS or vent gas treatment unit is not required, which offers considerable savings. Alternatively the vent gas may be combined with a hydrocarbon feedstock fed to the synthesis gas generation unit.

10 Alternatively, the formaldehyde vent gas may be recycled directly to the carbon dioxide removal stage so that the carbon dioxide and water vapour present in the vent gas may be captured. Organic contaminants such as methanol, formaldehyde and dimethyl ether may also be captured, e.g. using a PSA unit.

15 Alternatively, the formaldehyde vent gas maybe recycled directly to the methanol synthesis stage. Direct recycling is simpler and is preferred. With direct recycling, the by-products will be limited by equilibrium across the methanol synthesis catalyst and so will not accumulate in this recycle loop. The nitrogen is also recovered without the need for catalytic combustion or intensive pressurisation.

20 The formaldehyde vent gas may be recycled directly to one, two or more of these alternatives.

The formaldehyde production unit may also produce an aqueous waste stream, for example a condensate recovered as a by-product of the methanol oxidation. This condensate may
25 contain organic compounds such as methanol, formaldehyde and dimethyl ether and therefore provide a potential source of hydrocarbon for the process. In one embodiment, the process condensate is recycled to the synthesis gas generation stage where it is used to generate steam for use in steam reforming. The steam may be formed in a conventional boiler and added to the hydrocarbon feed or may, preferably, be generated in a saturator to
30 which the aqueous effluent and hydrocarbon are fed. Alternatively the effluent may be fed to a process condensate stripper.

In the methanation stage (f), residual carbon monoxide and carbon dioxide in the methanol synthesis off-gas stream is converted to methane in the methanator. Any suitable
35 arrangement for the methanator may be used. Thus the methanator may be operated adiabatically or isothermally. One or more methanators may be used. A nickel-based methanation catalyst may be used. For example, in a single methanation stage, the gas from the methanol synthesis stage may be fed at an inlet temperature in the range 200-400°C, preferably 325-375°C, to a fixed bed of pelleted nickel-containing methanation catalyst.
40 Higher inlet temperatures are useful to decompose any methanol in the feed gas. Such

catalysts are typically pelleted compositions, comprising 20-40% wt nickel. Such methanation apparatus and catalysts are commercially available. The pressure for methanation may be in the range 10-80 bar abs or higher up to 250 bar abs. Steam is formed as a by-product of methanation. The steam is desirably removed using conventional means such as cooling and separation of condensate. An ammonia synthesis gas stream may be recovered from the methanation and drying stage. Such methanation apparatus and catalysts are commercially available.

The methanated gas stream may be fed to the ammonia production unit as the ammonia synthesis gas. However, the hydrogen:nitrogen molar ratio of the methanated gas stream may need to be adjusted, for example by addition of nitrogen from a suitable source, to provide the ammonia synthesis gas. The adjustment of the hydrogen:nitrogen molar ratio is to ensure the ammonia synthesis reaction operates efficiently. The nitrogen may be provided from any source, for example from an air separation unit (ASU). The adjustment may be performed by direct addition of nitrogen to the methanated gas stream. The adjusted gas mixture may then be passed to the ammonia synthesis unit as the ammonia synthesis gas.

Ammonia is synthesised in step (g). The ammonia synthesis gas may be compressed to the ammonia synthesis pressure and passed to an ammonia production unit. The ammonia production unit comprises an ammonia converter containing an ammonia synthesis catalyst. The nitrogen and hydrogen react together over the catalyst to form the ammonia product. Ammonia synthesis catalysts are typically iron based but other ammonia synthesis catalysts may be used. The reactor may operate adiabatically or may be operated isothermally. The catalyst beds may be axial and/or radial flow and one or more beds may be provided within a single converter vessel. The conversion over the catalyst is generally incomplete and so the synthesis gas is typically passed to a loop containing a partially reacted gas mixture recovered from the ammonia converter and the resulting mixture fed to the catalyst. The synthesis gas mixture fed to the loop may have a hydrogen:nitrogen ratio of 2.2-3.2. In the ammonia production unit, the hydrogen/nitrogen mixture may be passed over the ammonia synthesis catalyst at high pressure, e.g. in the range 80-350 bar abs, preferably 150-350 bar abs for large-scale plants, and a temperature in the range 300-540°C, preferably 350-520°C.

A purge gas stream containing methane and hydrogen may be taken from the ammonia synthesis loop and fed to the synthesis gas generation step or used as a fuel.

Compression of the synthesis gas is preferably effected in multiple stages, with a first and a second stage performed before the methanol synthesis to achieve e.g. 50-100 barg, preferably 80-100 barg, and a third stage after methanation to achieve a higher pressure, e.g. 150-250 barg, before the ammonia synthesis. Thus methanol synthesis may usefully be provided between the second and third stages of compression, with the methanator

downstream of methanol synthesis and upstream of the third stage of compression.

Alternatively, the methanol synthesis may usefully be provided upstream of the first stage of compression.

- 5 Urea is produced in step (h) by reacting ammonia from step (g) with carbon dioxide recovered from step (c). Typically only a portion of the ammonia produced in step (g) will be used to produce urea, which is limited by the amount of carbon dioxide recovered in step (c). The excess ammonia may be recovered and used to make nitric acid, ammonium nitrate or ammonia products for sale. Any urea production technology may be used. For example,
10 ammonia and carbon dioxide may be combined in a first reactor in the range 140-200°C and 120-220 bar abs to form ammonium carbamate as follows;



- 15 The ammonium carbamate is then dehydrated in a further reactor to form urea;



- The high pressure favours ammonium carbamate formation and the high temperature favours
20 the dehydration, so the resultant mixture contains all the above components. Unreacted carbamate is therefore generally decomposed back to ammonia and carbon dioxide, which may then be recycled to the reactor. The carbon dioxide readily dissolves in the water from the dehydration, which if recycled suppresses the equilibria and so the system may be run with excess ammonia to minimise this recycle. The decomposition and subsequent recycling can
25 be carried out in one or more successive stages at decreasing pressures to minimise the ultimate concentration of ammonium carbamate dissolved in the urea solution. An alternative process arrangement uses the fresh carbon dioxide gas to strip unreacted ammonia and carbon dioxide from the ammonium carbamate and urea solution at the same pressure as the reactor. Further unreacted material is recycled from lower pressure stages as ammonium
30 carbamate solution. Such urea production apparatus is commercially available.

- Formaldehyde-stabilised urea is produced in step (i) by mixing urea produced in step (h) stream and a stabiliser prepared using formaldehyde recovered from the formaldehyde production unit in step (e). The stabiliser may be any formaldehyde-containing stabiliser;
35 including aqueous formaldehyde and an aqueous urea-formaldehyde concentrate. Aqueous formaldehyde and urea formaldehyde concentrate may be prepared directly in the formaldehyde production unit. Formaldehyde, either as a concentrated solution or as a combined solution of urea and formaldehyde may be added to molten urea prior to forming into either prills or granules. This reduces the tendency of the urea to absorb moisture and
40 increases the hardness of the surface of the solid particles, preventing both caking (bonding

of adjacent particles) and dusting (abrasion of adjacent particles). This maintains the free flowing nature of the product; prevents loss of material through dust, and enhances the stability during long term storage. If urea is available then it is preferable to use the urea formaldehyde solution as a stable solution with a higher formaldehyde concentration can be produced, which minimises the water being added to the molten urea. Such stabilised urea production apparatus is commercially available.

The present invention will now be described by way of example with reference to the accompanying drawings in which;

10 Figure 1 is a schematic representation of a process according to a first aspect of the present invention including by-pass of the one or more water-gas shift reactors, and Figure 2 is a schematic representation of a process according to a second aspect of the present invention including by-pass of the carbon dioxide removal unit.

15 It will be understood by those skilled in the art that the drawings are diagrammatic and that further items of equipment such as reflux drums, pumps, vacuum pumps, temperature sensors, pressure sensors, pressure relief valves, control valves, flow controllers, level controllers, holding tanks, storage tanks, and the like may be required in a commercial plant. The provision of such ancillary items of equipment forms no part of the present invention and
20 is in accordance with conventional chemical engineering practice.

In Figure 1, a natural gas stream 10, steam 12 and an air stream 14 are fed to a synthesis gas generation unit 18 comprising a primary reformer and secondary reformer. The natural gas is primary reformed with steam in externally-heated catalyst filled tubes and the primary reformed gas subjected to secondary reforming in the secondary reformer with the air to
25 generate a raw synthesis gas comprising nitrogen, hydrogen, carbon dioxide, carbon monoxide and steam. A portion of the natural gas may by-pass the primary reformer and be fed along with the primary reformed gas to the secondary reformer. A flue gas 16 is discharged from the primary reformer. The steam to carbon monoxide ratio of the raw synthesis gas may be adjusted by steam addition if necessary and the gas subjected to
30 water-gas shift in a high temperature shift reactor 20 containing a high temperature shift catalyst and then a low temperature shift reactor 22 containing a low temperature shift catalyst. The water-gas shift reaction increases the hydrogen and carbon dioxide contents and the steam and carbon monoxide contents are decreased. The shifted synthesis gas is fed to a carbon dioxide removal unit 24 operating by means of reactive absorption. A carbon dioxide and water stream is recovered from the separation unit 24 by line 26 for further use.
35 A carbon dioxide-depleted synthesis gas 28 comprising hydrogen, carbon monoxide and nitrogen is passed from the carbon dioxide removal unit 24 to a methanol synthesis unit 30 comprising a methanol converter containing a bed of methanol synthesis catalyst. Upstream of the methanol synthesis unit 30, water in the shifted gas and the carbon dioxide-depleted
40

synthesis gas is removed by cooling and separation of the condensate. The dried carbon dioxide-depleted synthesis gas is then heated and fed to the methanol synthesis unit. Methanol is synthesised in the converter on a once-through basis, separated from the product gas mixture and recovered from the methanol synthesis unit 30. The methanol is passed via line 32 to a formaldehyde production unit 34 comprising an oxidation reactor containing an oxidation catalyst. An air source 36 is fed to the oxidation reactor where it is reacted with the methanol to produce formaldehyde. The oxidation reactor is operated in a loop with a portion of the reacted gas fed to the inlet of the reactor. The formaldehyde production unit is fed with cooling water 38 and generates a steam stream 40 and a formaldehyde vent gas 42. The formaldehyde is recovered in an absorption tower which may be fed with water or urea via line 67 such that either aqueous formaldehyde or a urea-formaldehyde concentrate (UFC) product stream 44 may be recovered from the formaldehyde production unit 34 for further use. A portion of the formaldehyde product stream 45 can be taken for use in, for example, a separate urea-stabilisation plant or for sale, if the flow of formaldehyde produced is in excess of that required for the associated urea plant. A methanol synthesis off-gas stream 46 comprising hydrogen, nitrogen and unreacted carbon monoxide recovered from the methanol synthesis unit 30 is passed to a methanation unit 48 comprising a methanation reactor containing a bed of methanation catalyst. Carbon oxides remaining in the off-gas 46 are converted to methane and water in the methanation reactor. Water is recovered from the methanation unit 48 by line 50. The methanated off-gas is an ammonia synthesis gas comprising nitrogen, hydrogen and methane. The ammonia synthesis gas is passed from the methanation unit 48 by line 52 to an ammonia synthesis unit 54 comprising an ammonia converter containing one or more beds of ammonia synthesis catalyst. The ammonia converter is operated in a loop with a portion of the reacted gas fed to the inlet of the converter. Ammonia is produced in the converter and recovered from the ammonia synthesis unit 54 by line 56. A purge gas stream 60 comprising methane and unreacted hydrogen and nitrogen is recovered from the ammonia synthesis unit 54 and provided to the synthesis gas generation unit 18 as fuel and/or feed to the primary and/or secondary reformers. A vent gas stream 62 is also recovered from the ammonia synthesis unit 54. A portion 58 of the ammonia is separated from the product stream 56. The remaining ammonia is passed to a urea synthesis unit 64 where it is reacted with a purified carbon dioxide stream provided by stream 26 to produce a urea stream and water. Water is recovered from the urea synthesis unit 64 by line 66. The urea stream is passed by line 68 to a stabilisation unit 70 comprising a stabilisation vessel where it is treated with aqueous formaldehyde or a urea formaldehyde concentrate provided by line 44 to form a formaldehyde-stabilised urea product. The formaldehyde-stabilised urea product is recovered from the stabilisation unit 70 by line 72.

In Figure 1, in order to adjust the carbon oxides content of the gas stream 28 fed to the methanol synthesis unit 30, one or more by-pass streams are provided around the water-gas shift reactors. Thus in one aspect, a by-pass stream 74 conveys a portion of the raw

synthesis gas produced by the synthesis gas generation unit 18 around the high temperature shift reactor 20 to the feed to the low temperature shift reactor 22. In an alternative aspect, a by-pass stream 76 conveys a portion of the high temperature shifted synthesis gas around the low temperature shift reactor 22 and to the feed stream to the carbon dioxide removal unit 24. In a preferred aspect, a by-pass stream 78 conveys a portion of the raw synthesis gas produced by the synthesis gas generation unit 18 around the high temperature shift reactor 20 and the low temperature shift reactor 22 directly to the feed stream to the carbon dioxide removal unit 24.

10 In Figure 2, the synthesis gas generation, water-gas shift, carbon dioxide removal, methanol synthesis, methanation, formaldehyde synthesis, ammonia synthesis, urea synthesis and stabilisation step are the same as depicted in Figure 1.

However, in Figure 2, in order to adjust the carbon oxides content of the gas stream 28 fed to the methanol synthesis unit 30, one or more by-pass streams are provided around the carbon dioxide removal unit 24. Thus in one aspect, a by-pass stream 80 conveys a portion of the shifted synthesis gas produced by the low temperature shift reactor 22 around the carbon dioxide removal unit 24 to the feed stream 28 to the methanol synthesis unit 30. In an alternative aspect, a by-pass stream 82 conveys a portion of the high temperature shifted synthesis gas around the low temperature shift reactor 22 and the carbon dioxide removal unit to the feed stream 28 to the methanol synthesis unit 30. In an alternative aspect, a by-pass stream 84 conveys a portion of the raw synthesis gas produced by the synthesis gas generation unit 18 around the high temperature shift reactor 20, the low temperature shift reactor 22 and the carbon dioxide removal unit 24 directly to the feed stream 28 to the methanol synthesis unit 30.

The present invention will now be described with reference to the following example.

A process according to Figure 1 was modelled to determine the effect of by-passing a portion of the process gas 76 around the low temperature shift reactor 22. The synthesis gas generation was by primary and secondary steam reforming with air of natural gas with, both high temperature and low temperature water-gas shift. There was no hydrocarbon by-pass of the primary reformer to the secondary reformer. The formaldehyde product was produced using the air oxidation of the methanol over a particulate iron/molybdenum catalyst disposed in cooled tubes, with recycle of a portion of the unreacted gas to control the temperature within the oxidation reactor. The methanol synthesis was performed on a once through basis and the ammonia synthesis was performed with recycle of a portion of the product gas to maximise ammonia production. The compositions, pressures and temperatures for the various streams are given below.

40

Stream mole% dry	10	12	14	36	26	28	32	46	52
N ₂	1.32		78.08	78.08	0.16	23.61	0.04	24.52	24.91
O ₂			20.96	20.96					
H ₂	2.81				0.65	73.69	0.01	73.90	73.48
NH ₃									
CH ₄	91.81				0.01	0.62	0.01	0.64	1.22
Ar	0.01		0.93	0.93		0.36		0.38	
CO ₂	2.56		0.03	0.03	99.15	0.10	0.01	0.03	
CO					0.03	1.62		0.45	
C ₂ H ₆	1.23								
C ₃ H ₈	0.02								
C ₄ +	0.24								
CH ₃ OH							99.92	0.08	
CH ₂ O									
CO(NH ₂) ₂									
Dry Flow kmol/hr	1525.0		1988.2	240.2	1359.7	6658.1	78.2	6408.8	6308.7
H ₂ O kmol/hr		4369.4	151.1	18.3	2559.8	2.5	6.7	0.2	1.1
Total flow kmol/hr	1525.0	4369.4	2139.3	258.5	3919.5	6660.6	84.9	6409.0	6309.8
Temperature °C	365	390		25		225	10	350	103
Pressure bar abs	44	45		1	1	92	3	90	182

Stream mole% dry	56	68	67	44	42	72	76
N ₂	<0.01				92.46		20.52
O ₂					5.49		
H ₂	<0.01						59.71
NH ₃	99.99	0.18	0.18				
CH ₄	0.01						0.43
Ar							0.24
CO ₂							15.25
CO							3.85
C ₂ H ₆							
C ₃ H ₈							
C ₄ +							
CH ₃ OH				0.24	0.18	<0.01	
CH ₂ O		0.04	0.04	82.50	0.02	1.10	
CO(NH ₂) ₂		99.78	99.78	17.19		98.89	
Dry Flow kmol/hr	3067.3	1225.6	14.8	84.8	200.6	1236.5	2299.2
H ₂ O kmol/hr		172.3	48.1	28.5	5.8	8.2	840.2
Total flow kmol/hr	3067.3	1397.8	62.9	113.3	206.4	1244.7	3139.5
Temperature °C	22	133	45	30	30	95	205
Pressure bar abs	17	1	4	3	1	1	32

This example relates to a 1,200 mtpd ammonia plant that makes 86 mtpd of UFC-85, for which about 60 mtpd of methanol is required. In this case (Case 1), the process characteristics are as follows;

	Units	Case 1
By-pass flow rate as % of the reformed synthesis gas flow rate	mol %	30
Carbon monoxide in by-pass	mol% (dry)	3.85
Carbon dioxide in by-pass	mol% (dry)	15.25
Carbon monoxide inlet methanol synthesis	mol% (dry)	1.62
Carbon dioxide inlet methanol synthesis	mol% (dry)	0.01
Water content of crude methanol	% wt	4.6
Relative size of methanol synthesis catalyst bed	%	100

5

The proportion of the gas flow that is diverted to the by-pass stream in Case 1 is relatively high as a large portion of the carbon oxides are removed in the carbon dioxide removal unit. In comparison, Case 2, modelled according to Figure 2, refers to the situation where there is a by-pass stream 82 around the low temperature shift reactor 22 and the carbon dioxide removal unit 24. In comparison, Case 3, again modelled according to Figure 2, refers to the situation where there is a by-pass stream 84 around the high temperature shift reactor 20, the low temperature shift reactor 22 and the carbon dioxide removal unit 24. That is, a single by-pass stream around all three units, transferring a portion of the synthesis gas to the carbon dioxide-depleted gas stream. The model results are shown below.

10
15

	Units	Case 2	Case 3
By-pass flow rate as % of the reformed synthesis gas flow rate	Mole %	7	6
Carbon monoxide in by-pass	mol% (dry)	3.85	13.81
Carbon dioxide in by-pass	mol% (dry)	15.25	7.12
Carbon monoxide inlet methanol synthesis	mol% (dry)	0.70	1.27
Carbon dioxide inlet methanol synthesis	mol% (dry)	1.29	0.53
Water content of crude methanol	% wt	32.6	17.1
Relative size of methanol synthesis catalyst bed	%	63	79

By comparison to Case 1 above, the proportion of the process gas stream being by-passed around the units is significantly smaller.

20

Claims

1. A process for the production of formaldehyde-stabilised urea comprising:
 - a) generating a synthesis gas comprising hydrogen, nitrogen, carbon monoxide, carbon dioxide and steam in a synthesis gas generation unit,
 - b) subjecting the synthesis gas to one or more stages of water-gas shift in one or more water-gas shift reactors to form a shifted gas;
 - c) recovering carbon dioxide from the shifted gas in a carbon dioxide removal unit to form a carbon dioxide-depleted synthesis gas;
 - d) synthesising methanol from the carbon dioxide-depleted synthesis gas in a methanol synthesis unit and recovering the methanol and a methanol synthesis off-gas comprising nitrogen, hydrogen and residual carbon monoxide;
 - e) subjecting at least a portion of the recovered methanol to oxidation with air in a formaldehyde production unit;
 - f) subjecting the methanol synthesis off-gas to methanation in a methanation reactor containing a methanation catalyst to form an ammonia synthesis gas;
 - g) synthesising ammonia from the ammonia synthesis gas in an ammonia production unit and recovering the ammonia;
 - h) reacting a portion of the ammonia and at least a portion of the recovered carbon dioxide stream in a urea production unit to form a urea stream; and
 - i) stabilising the urea by mixing the urea stream and a stabiliser prepared using formaldehyde recovered from the formaldehyde production unit,

wherein a portion of the synthesis gas generated by the synthesis gas generation unit by-passes either the one or more water-gas shift reactors; the carbon dioxide recovery unit; or the one or more water-gas shift reactors and the carbon dioxide removal unit.

2. The process according to claim 1, wherein the synthesis gas is generated by steam reforming of a hydrocarbon feedstock comprising natural gas, naphtha or a refinery off-gas; or by the gasification of a carbonaceous feedstock, comprising coal or biomass.

3. The process according to claim 1 or claim 2, wherein the synthesis gas is generated by adiabatic pre-reforming and/or primary reforming a hydrocarbon feedstock in a primary fired or gas-heated steam reformer and secondary or autothermal reforming with air or oxygen-enriched air.
4. The process according to claim 3, wherein a portion of the hydrocarbon feedstock by-passes the primary fired or gas-heated steam reformer.
5. The process according to any one of claims 1 to 4, wherein a source of air is compressed and divided into first and second portions, the first portion is provided to the formaldehyde production unit for the oxidation of methanol and the second portion is further compressed and provided to the synthesis gas generation unit.
6. The process according to any one of claims 1 to 5, wherein the one or more stages of water-gas shift comprise one or more stages of high temperature shift, low temperature shift, medium temperature shift, isothermal shift and sour shift.
7. The process according to claim 6, wherein the one or more stages of water-gas shift comprise one or more stages of high temperature shift, a single stage of high temperature shift, a combination of high temperature shift and low temperature shift, a single stage of medium temperature shift, or a combination of medium temperature shift and low temperature shift.
8. The process according to any one of claims 1 to 7, wherein the one or more stages of water-gas shift consists of a high temperature shift reactor and a low temperature shift reactor and the portion of the synthesis gas by-passes either the high temperature shift reactor, the low temperature shift reactor or both the high temperature shift reactor and the low temperature shift reactor.
9. The process according to any one of claims 1 to 8, wherein carbon dioxide removal in c) is effected using absorption or adsorption.
10. The process according to any one of claims 1 to 9, wherein the methanol synthesis in d) is operated on a once-through basis, or on a recycle basis in which unreacted gases, after methanol condensate removal, are returned to a methanol converter in a loop.
11. The process according to any one of claims 1 to 10, wherein the methanol synthesis in d) is operated in a single stage at an inlet temperature in the range 200-320°C.

12. The process according to claim 11, wherein the methanol synthesis in d) is operated in a single stage at an inlet temperature in the range 200-270°C.

13. The process according to any one of claims 1 to 12, wherein crude methanol recovered from the methanol synthesis stage is fed to the oxidation reactor.

14. The process according to claim 13, wherein the crude methanol contains $\leq 20\%$ wt water.

15. The process according to any one of claims 1 to 14, wherein the formaldehyde production unit in e) comprises an oxidation reactor containing a bed of oxidation catalyst and is operated with or without recycle of oxidised gas to an inlet of the oxidation reactor.

16. The process according to any one of claims 1 to 15, wherein the formaldehyde production unit in e) generates a formaldehyde vent gas which is recycled to the process, either directly or after one or more stages of vent gas treatment in a vent-gas treatment unit.

17. The process according to claim 16, wherein the vent gas treatment unit comprises a gas-liquid separator that separates a nitrogen-rich off-gas from liquid methanol.

18. The process according to claim 16, wherein the formaldehyde vent gas is recycled directly without treatment to the methanol synthesis stage or indirectly after first passing to an emission control unit comprising a catalytic combustor to convert a vent stream into carbon dioxide, nitrogen and steam.

19. The process according to claim 16, wherein the formaldehyde vent gas is recycled directly without treatment to the carbon dioxide removal stage or indirectly after first passing to an emission control unit comprising a catalytic combustor to convert a vent stream into carbon dioxide, nitrogen and steam.

20. The process according to claim 16, wherein the formaldehyde vent gas is recycled after first passing to an emission control unit comprising a catalytic combustor to convert a vent stream into carbon dioxide, nitrogen and steam to the urea synthesis stage.

21. The process according to claim 16, wherein the formaldehyde vent gas is recycled directly to the synthesis gas generation unit as a component of a fuel gas.

22. A process for producing formaldehyde-stabilised urea comprising:

- (A) generating a synthesis gas comprising hydrogen, nitrogen, carbon monoxide, carbon dioxide and steam in a synthesis gas generation unit;
- (B) subjecting the synthesis gas to one or more stages of water-gas shift in one or more water-gas shift reactors to form a shifted gas;
- (C) recovering carbon dioxide from the shifted gas in a carbon dioxide removal unit to form a carbon dioxide-depleted synthesis gas;
- (D) passing the carbon dioxide-depleted synthesis gas through a methanol synthesis unit to synthesize a crude methanol and recovering the crude methanol and a methanol synthesis off-gas stream comprising nitrogen, hydrogen and residual carbon monoxide;
- (E) oxidizing at least a portion of the recovered crude methanol with air in a formaldehyde production unit to produce an oxidised gas containing formaldehyde and a formaldehyde vent gas, the crude methanol having been adjusted to have a water content in a range of from 5 wt% to 20 wt%;
- (F) methanating the methanol synthesis off-gas in a methanation reactor containing a methanation catalyst to form an ammonia synthesis gas;
- (G) synthesising ammonia from the ammonia synthesis gas in an ammonia production unit and recovering the ammonia;
- (H) reacting a portion of the ammonia and at least a portion of the recovered carbon dioxide in a urea production unit to form a urea stream; and
- (I) stabilising the urea by mixing the urea stream and a stabiliser prepared using formaldehyde recovered from the formaldehyde production unit,

wherein:

- (i) a portion of the synthesis gas generated by the synthesis gas generation unit by-passes (a) one or more water-gas shift reactors; or (b) one or more water-gas shift reactors and the carbon dioxide removal unit; or
- (j) a portion of the shifted gas by-passes the carbon dioxide removal unit; and wherein the crude methanol recovered from (D) is fed to oxidizing step (E).

23. The process according to claim 22, wherein the synthesis gas is generated by steam reforming a hydrocarbon or gasifying a carbonaceous feedstock.

24. The process according to claim 22, wherein the synthesis gas is generated from a hydrocarbon by adiabatic pre-reforming, primary reforming in a primary fired or gas-heated steam reformer and secondary or autothermal reforming with air or oxygen-enriched air, or a combination thereof.

25. The process according to claim 24, wherein a portion of the hydrocarbon by-passes the primary fired or gas-heated steam reformer.

26. The process according to claim 22, further comprising compressing and dividing a source of air into a first portion that is provided to the formaldehyde production unit of step (E) for oxidizing methanol and a second portion that is further compressed and provided to the synthesis gas generation unit of step (A).

27. The process according to claim 22, wherein the one or more stages of water-gas shift of step (B) comprise one or more stages of high temperature shift, low temperature shift, medium temperature shift, isothermal shift, or sour shift.

28. The process according to claim 22, wherein the one or more stages of water-gas shift in step (B) consists of a high temperature shift reactor and a low temperature shift reactor and the portion of the synthesis gas by-passes either the high temperature shift reactor, or both the high temperature shift reactor and the low temperature shift reactor, or a portion of a high-temperature shifted gas by-passes the low temperature shift reactor.

29. The process according to claim 22, wherein carbon dioxide is removed in step (C) using absorption or adsorption.

30. The process according to claim 22, wherein the methanol synthesis of step (D) is performed on a once-through basis, or on a recycle basis wherein unreacted gases, after methanol condensate removal, are returned to the methanol synthesis unit.

31. The process according to claim 22, wherein the methanol synthesis unit of step (D) is operated in a single stage at an inlet temperature in the range of from 200-320°C.

32. The process according to claim 22, wherein the formaldehyde production unit of step (E) comprises an oxidation reactor containing a bed of oxidation catalyst.

33. The process according to claim 22, wherein the formaldehyde production unit of step (E) generates a formaldehyde vent gas which is directly recycled or recycled after one or more stages of vent gas treatment in a vent-gas treatment unit.

34. The process according to claim 33, wherein the vent gas treatment unit comprises a gas-liquid separator that separates a nitrogen-rich off-gas from liquid methanol.

35. The process according to claim 33, wherein the formaldehyde vent gas is recycled to the methanol synthesis step (D) either directly without treatment or indirectly after first passing to an emission control unit comprising a catalytic combustor to convert a vent stream into carbon dioxide, nitrogen and steam.

36. The process according to claim 33, wherein the formaldehyde vent gas is recycled to the carbon dioxide removal step (C) either directly without treatment or indirectly after first passing to an emission control unit comprising a catalytic combustor to convert a vent stream into carbon dioxide, nitrogen and steam.

37. The process according to claim 33, wherein the formaldehyde vent gas is recycled to the urea synthesis stage after first passing to an emission control unit comprising a catalytic combustor to convert a vent stream into carbon dioxide, nitrogen and steam.

38. The process according to claim 33, wherein the formaldehyde vent gas is recycled directly to a synthesis gas generation unit comprising the synthesis gas.

39. The process according to claim 22, wherein the one or more stages of water-gas shift of step (B) comprise a single stage of high temperature shift, a combination of high temperature shift and low temperature shift, a single stage of medium temperature shift, or a combination of medium temperature shift and low temperature shift.

40. The process according to claim 22, wherein (i) a portion of the synthesis gas generated by the synthesis gas generation unit by-passes (a) one or more water-gas shift reactors.

41. The process according to claim 22, wherein (i) a portion of the synthesis gas generated by the synthesis gas generation unit by-passes (b) one or more water-gas shift reactors and the carbon dioxide removal unit.

42. The process according to claim 22, wherein (ii) a portion of the shifted gas by-passes the carbon dioxide removal unit.

43. A process for the production of formaldehyde-stabilised urea comprising the steps of:

- (a) generating a synthesis gas comprising hydrogen, nitrogen, carbon monoxide, carbon dioxide and steam in a synthesis gas generation unit,
- (b) subjecting the synthesis gas to one or more stages of water-gas shift in one or more water-gas shift reactors to form a shifted gas;
- (c) recovering carbon dioxide from the shifted gas in a carbon dioxide removal unit to form a carbon dioxide-depleted synthesis gas;
- (d) synthesising methanol from the carbon dioxide-depleted synthesis gas in a methanol synthesis unit and recovering the methanol and a methanol synthesis off-gas comprising nitrogen, hydrogen and residual carbon monoxide;
- (e) subjecting at least a portion of the recovered methanol to oxidation with air in a formaldehyde production unit;
- (f) subjecting the methanol synthesis off-gas to methanation in a methanation reactor containing a methanation catalyst to form an ammonia synthesis gas;
- (g) synthesising ammonia from the ammonia synthesis gas in an ammonia production unit and recovering the ammonia;
- (h) reacting a portion of the ammonia and at least a portion of the recovered carbon dioxide stream in a urea production unit to form a urea stream; and
- (i) stabilising the urea by mixing the urea stream and a stabiliser prepared using formaldehyde recovered from the formaldehyde production unit,

wherein a portion of the synthesis gas generated by the synthesis gas generation unit by-passes either the one or more water-gas shift reactors; the carbon dioxide recovery unit; or the one or more water-gas shift reactors and the carbon dioxide removal unit, and wherein crude methanol recovered from the methanol synthesis stage is fed to an oxidation reactor in the formaldehyde production unit.

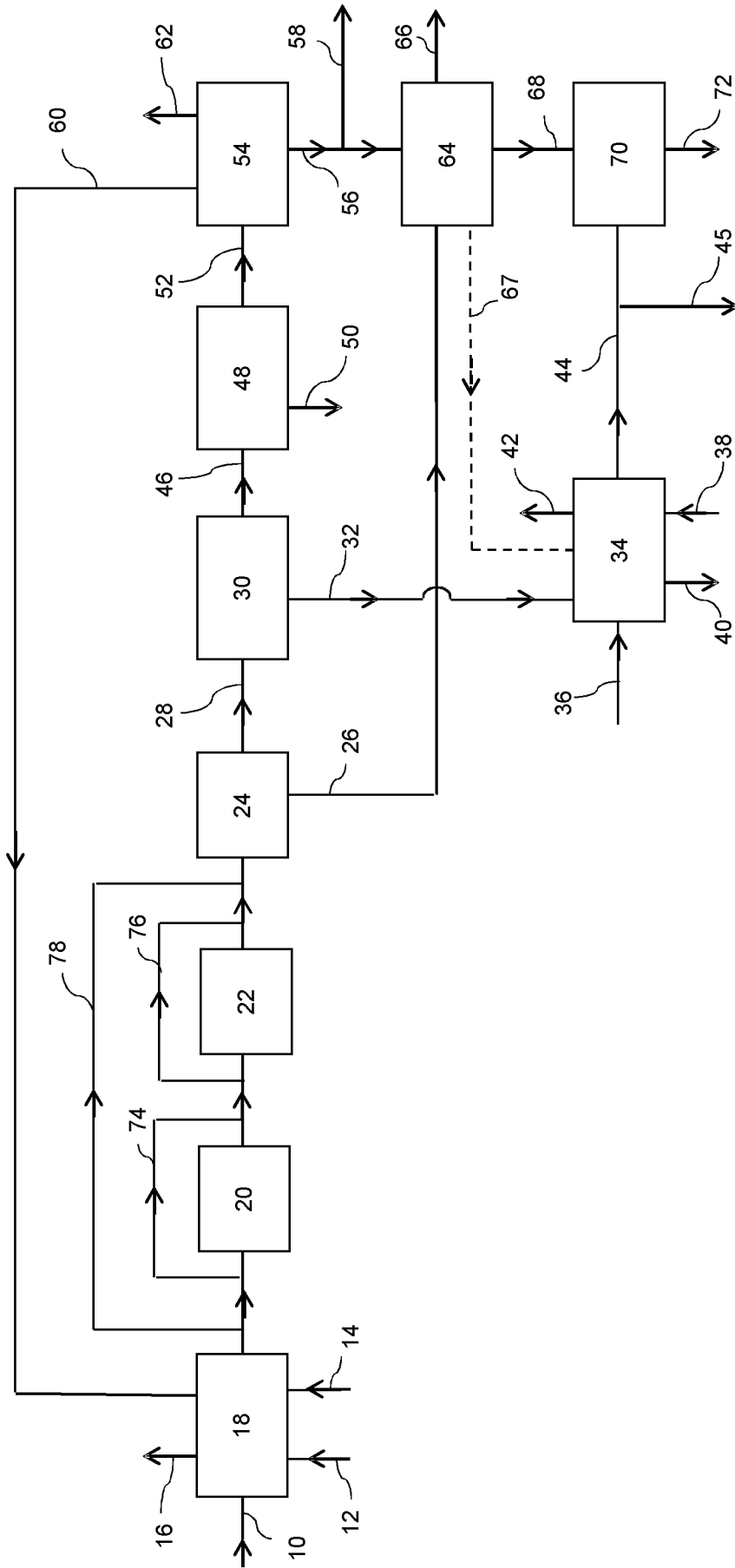

Figure 1

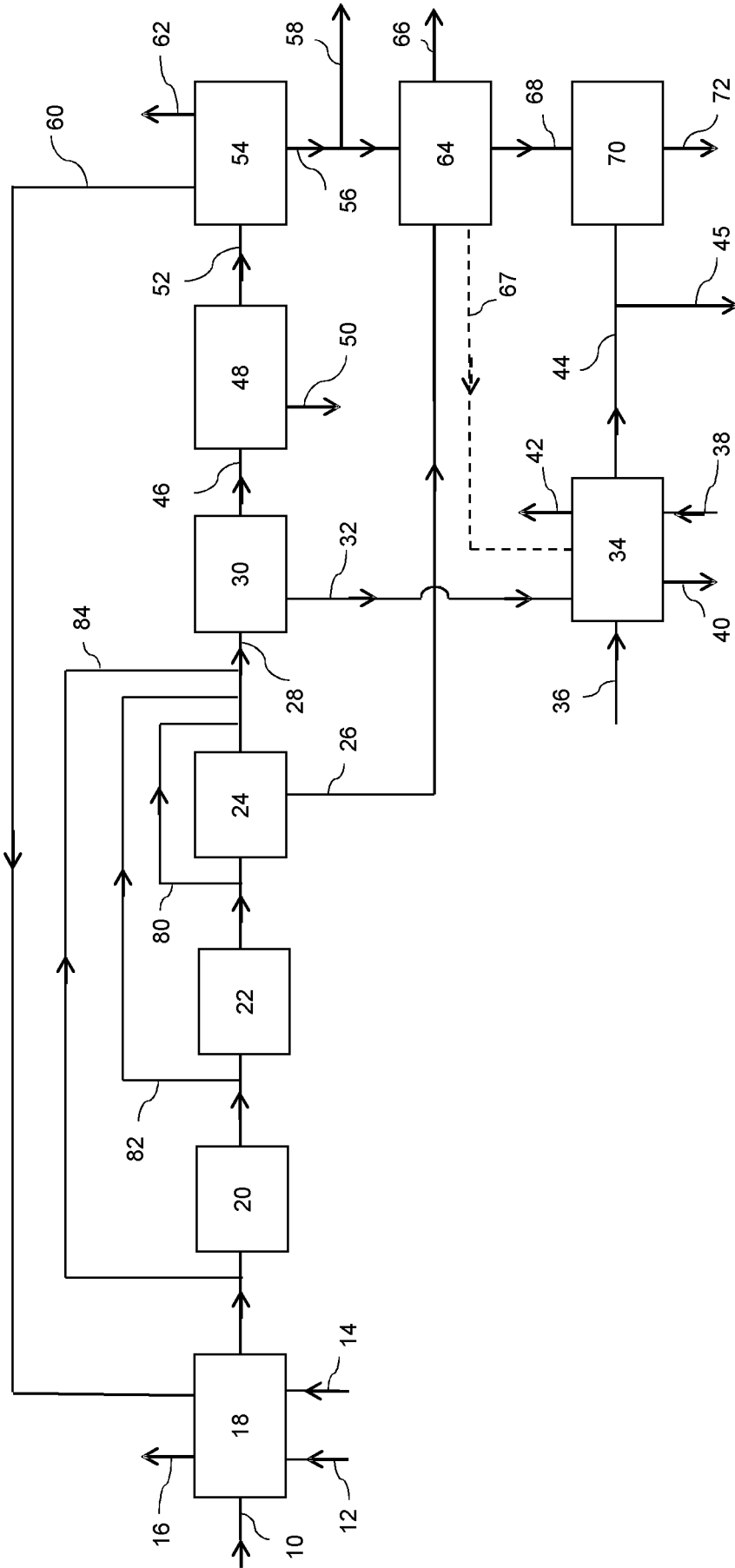

Figure 2

