

(19) **DANMARK**

(10) **DK/EP 3569909 T3**



(12) **Oversættelse af  
europæisk patentskrift**

Patent- og  
Varemærkestyrelsen

- 
- (51) Int.Cl.: **F 16 L 27/047 (2006.01)** **F 16 L 27/053 (2006.01)**
- (45) Oversættelsen bekendtgjort den: **2024-02-19**
- (80) Dato for Den Europæiske Patentmyndigheds bekendtgørelse om meddelelse af patentet: **2023-11-29**
- (86) Europæisk ansøgning nr.: **19168590.8**
- (86) Europæisk indleveringsdag: **2019-04-11**
- (87) Den europæiske ansøgnings publiceringsdag: **2019-11-20**
- (30) Prioritet: **2018-05-14 US 201815978293**
- (84) Designerede stater: **AL AT BE BG CH CY CZ DE DK EE ES FI FR GB GR HR HU IE IS IT LI LT LU LV MC MK MT NL NO PL PT RO RS SE SI SK SM TR**
- (73) Patenthaver: **Freudenberg Flow Technologies LLC, 10035 Brookriver Drive, Suite 400, Houston TX Texas 77040, USA**
- (72) Opfinder: **Sheehan, Michael, 43 Riversdale Road, Swansea, SA3 5PX, Storbritannien**  
**Stobbart, John, 139 Gower Road, Swansea, SA2 9HS, Storbritannien**
- (74) Fuldmægtig i Danmark: **Budde Schou A/S, Dronningens Tværgade 30, 1302 København K, Danmark**
- (54) Benævnelse: **Fejlopretningsflange til rørledningsinstallationer**
- (56) Fremdragne publikationer:  
**EP-A2- 2 148 120**  
**DE-U1- 9 207 970**  
**GB-A- 1 596 794**  
**US-A- 5 368 342**  
**US-B1- 6 419 279**



# DESCRIPTION

## FIELD

[0001] The present disclosure relates to an improved misalignment flange for connecting two misaligned pipeline conduits in fluid-tight communication.

## BACKGROUND

[0002] This section provides background information related to the present disclosure which is not necessarily prior art.

[0003] It is common in the oil production and refining industry to utilize a ball and socket type flange to join two misaligned pipe ends. These prior art ball and socket flanges have found application in both above-sea environments and sub-sea environments.

[0004] Current misalignment flange designs require a large, heavy assembly. It is desirable to provide a misalignment flange design that is smaller, and lighter without compromising the sealing capability and without limiting the amount of misalignment that can be accommodated.

[0005] EP 2148120 A2 discloses a pipeline misalignment flange of the prior art.

## SUMMARY

[0006] The invention is a pipeline misalignment flange as defined in claim 1.

[0007] Further areas of applicability will become apparent from the description provided herein. The description and specific examples in this summary are intended for purposes of illustration only and are not intended to limit the scope of the present disclosure.

## DRAWINGS

[0008] The drawings described herein are for illustrative purposes only of selected embodiments and not all possible implementations, and are not intended to limit the scope of the present disclosure.

Figure 1 is a perspective cross-sectional view of a misalignment flange according to the principles of the present disclosure; and

Figure 2 is a cross-sectional view of the misalignment flange shown in Figure 1.

**[0009]** Corresponding reference numerals indicate corresponding parts throughout the several views of the drawings.

#### **DETAILED DESCRIPTION**

**[0010]** Example embodiments will now be described more fully with reference to the accompanying drawings.

**[0011]** Example embodiments are provided so that this disclosure will be thorough, and will fully convey the scope to those who are skilled in the art. Numerous specific details are set forth such as examples of specific components, devices, and methods, to provide a thorough understanding of embodiments of the present disclosure. It will be apparent to those skilled in the art that specific details need not be employed, that example embodiments may be embodied in many different forms and that neither should be construed to limit the scope of the disclosure. In some example embodiments, well-known processes, well-known device structures, and well-known technologies are not described in detail.

**[0012]** The terminology used herein is for the purpose of describing particular example embodiments only and is not intended to be limiting. As used herein, the singular forms "a," "an," and "the" may be intended to include the plural forms as well, unless the context clearly indicates otherwise. The terms "comprises," "comprising," "including," and "having," are inclusive and therefore specify the presence of stated features, integers, steps, operations, elements, and/or components, but do not preclude the presence or addition of one or more other features, integers, steps, operations, elements, components, and/or groups thereof. The method steps, processes, and operations described herein are not to be construed as necessarily requiring their performance in the particular order discussed or illustrated, unless specifically identified as an order of performance. It is also to be understood that additional or alternative steps may be employed.

**[0013]** When an element or layer is referred to as being "on," "engaged to," "connected to," or "coupled to" another element or layer, it may be directly on, engaged, connected or coupled to the other element or layer, or intervening elements or layers may be present. In contrast, when an element is referred to as being "directly on," "directly engaged to," "directly connected to," or "directly coupled to" another element or layer, there may be no intervening elements or layers present. Other words used to describe the relationship between elements should be interpreted in a like fashion (e.g., "between" versus "directly between," "adjacent" versus "directly adjacent," etc.). As used herein, the term "and/or" includes any and all combinations of one or more of the associated listed items.

**[0014]** With reference to Figures 1 and 2, the misalignment flange 10 according to the invention will now be described. The misalignment flange 10 includes a socket member 12, a ball member 14, a retainer member 16 and a plurality of fasteners 18. A first pipe 20 can be welded or otherwise connected to a weld flange 12a of the socket member 12 and a second pipe 22 can be welded or otherwise connected to a weld flange 14a of the ball member 14.

**[0015]** Socket member 12 includes a first substantially spherical internal surface 24 having a first diameter. The socket member 12 further includes a first mounting flange 26 having a plurality of apertures 28 for receiving fasteners 18. The retainer member 16 includes a second mounting flange 30 having a plurality of apertures 32 for receiving the fasteners 18 which mount the socket member 12 and the retainer member 16 together. Alternatively, the apertures and fasteners can be eliminated and the socket member 12 and retainer member 16 can be clamped together or otherwise secured together. The socket member 12 includes a first face surface 34 surrounding the first substantially spherical internal surface 24, with the first face having a recessed channel 36 disposed therein.

**[0016]** The retainer member 16 has a second substantially spherical internal surface 38 having a second diameter larger than the first diameter.

**[0017]** The ball member 14 has a first substantially spherical external surface 40 for engaging the first substantially spherical internal surface 24 of the socket member 12. The ball member 14 has a second substantially spherical external surface 42 for engaging the second substantially spherical internal surface 38 of the retainer member 16. The second substantially spherical external surface 42 includes an axially protruding portion 44 with a radial undercut 46. The ball member 14 is adjustably pivotable relative to the socket member 12 and retainer member 16 to account for misalignment between the first pipe 20 and the second pipe 22. The axially protruding portion 44 can be received in the recessed channel 36. The first substantially spherical external surface includes a metal seal ring 50 at a distal end thereof. The first substantially spherical internal surface 24 includes a recessed seal ring 52 engaging the first substantially spherical external surface 40.

**[0018]** The double ball design of the misalignment flange 10 gives the ability to keep the hydrostatic end load low while also having the increased load capacity. By placing the metal-to-metal seal ring 50 at the end point of the smaller inner bowl profile 40 allows the misalignment flange to maintain a smaller seal ring size. This, in turn, allows for a reduced hydrostatic end load. This also allows a significant reduction in raw material size. By including the larger outer ball profile 42, the misalignment flange also maintains a large load capacity with a large bearing surface and, as a result, a higher bending moment capacity without affecting the seal ring size. In addition, the larger outer ball 42 has an overlap at the front end that, at maximum misalignment, increases its load capacity. A comparative single ball design would have a far higher hydrostatic end load at the same pressure capacity expectation and, as a result, the overall package of the double-ball design can be greatly reduced, providing a significant weight and cost savings.

**[0019]** The use of the misalignment flange 10 allows subsea installations to be carried out quicker, thus reducing the cost of the overall operation. One or more misalignment flange 10 can be used as part of a jumper system to give the installation contractors an element of adjustment while eliminating the requirement for jumper flexible bends. This will reduce the requirement of costly, complex and time-consuming metrology measurements prior to final system installation. Additional uses for the misalignment flange 10 is for subsea pipeline installations. Often the actual length of pipe in the exact final location of equipment is unknown right up until the end of an installation program. With the use of the misalignment flange 10, redundancy can be added into the system and final adjustment can be completed prior to installation making the installation quicker and more cost-effective.

**[0020]** The foregoing description of the embodiments has been provided for purposes of illustration and description. It is not intended to be exhaustive or to limit the disclosure. Individual elements or features of a particular embodiment are generally not limited to that particular embodiment, but, where applicable, are interchangeable and can be used in a selected embodiment, even if not specifically shown or described. The same may also be varied in many ways. Such variations are not to be regarded as a departure from the disclosure, and all such modifications are intended to be included within the scope of the invention as long as they fall within the scope of the claims.

## **REFERENCES CITED IN THE DESCRIPTION**

### Cited references

This list of references cited by the applicant is for the reader's convenience only. It does not form part of the European patent document. Even though great care has been taken in compiling the references, errors or omissions cannot be excluded and the EPO disclaims all liability in this regard.

### **Patent documents cited in the description**

- [EP2148120A2 \[0005\]](#)

## PATENTKRAV

## 1. Rørledningsfejlopretningsflange (10) omfattende:

- 5 et muffeelement (12) med en første i det væsentlige sfæriske indvendig overflade (24), som har en første diameter, et holdeelement (16) med en anden i det væsentlige sfæriske indvendig overflade (38), som har en anden diameter, som er større end den første diameter, hvor muffeelementet (12) og holdeelementet (16) er fastgjort til hinanden, og
- 10 et kugleelement (14) med en første i det væsentlige sfæriske udvendig overflade (40) til at indgribe med muffeelementet (12), og som har en diameter, som er omtrent lig med den første diameter, og en anden i det væsentlige sfæriske udvendig overflade (42) til at indgribe med holdeelementet (16), og som har en diameter, som er omtrent lig med den anden diameter,
- 15 hvor muffeelementet (12) har en første flade (34), som omgiver den første i det væsentlige sfæriske indvendige overflade (24), hvilken første flade (34) har en tilbagetrukket kanal (36), hvor den i det væsentlige sfæriske udvendige overflade (42) omfatter en aksialt fremstående del (44) med en underskæring (46), kugleelementet (14) er vipbart i forhold til muffeelementet (12) således, at den aksialt fremstående del (44) i den anden i det væsentlige sfæriske udvendige overflade (42) modtages i den tilbagetrukne kanal (36), og
- 20 muffeelementet (12) og holdeelementet (16) omfatter hver især en montageflange (26, 30) med adskillige åbninger (28) til at modtage fastgørelseselementer (18) til at fastgøre muffeelementet (12) og holdeelementet (16) til hinanden, og
- 25 **kendetegnet ved, at** den første i det væsentlige sfæriske udvendige overflade (40) på kugleelementet (14) omfatter en metalforseglingsring (50) ved en distal ende deraf, hvor den første i det væsentlige sfæriske indvendige overflade (24) omfatter en tilbagetrukket forseglingsring (52) deri,
- 30 ved en maksimal fejlopretning imellem kugleelementet (14) og muffeelementet (12) tilvejebringer én side af den aksialt fremstående del (44) på kugleelementet (14) en fuldstændig overfladekontakt med den tilbagetrukne kanal (36).

2. Rørledningsfejlopretningsflange ifølge krav 1, hvor den første i det væsentlige sfæriske udvendige overflade (40) befinder sig ved en distal ende af kugleelementet (14).
- 35

3. Rørledningsfejlopretningsflange ifølge krav 1, som yderligere omfatter et første rør (20) svejst på en svejseflange (12a) på muffeelementet (12).
  
4. Rørledningsfejlopretningsflange ifølge krav 3, som yderligere omfatter et andet rør
- 5 (22) svejst på en svejseflange (14a) på kugleelementet (14).

# DRAWINGS

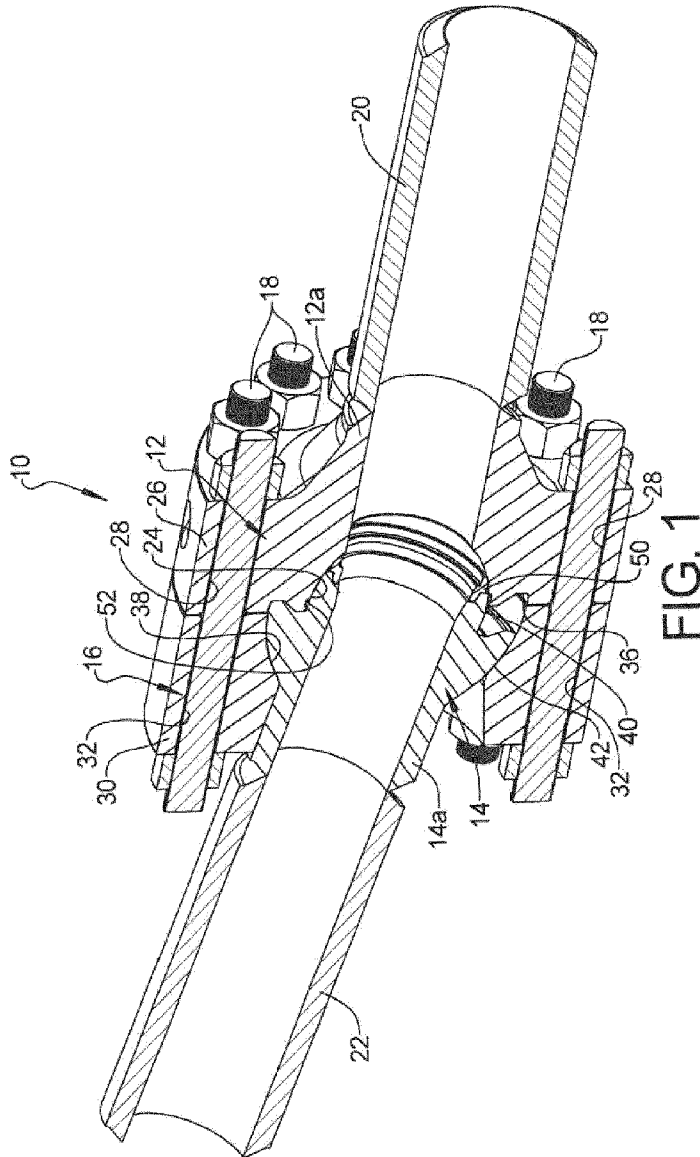

FIG. 1

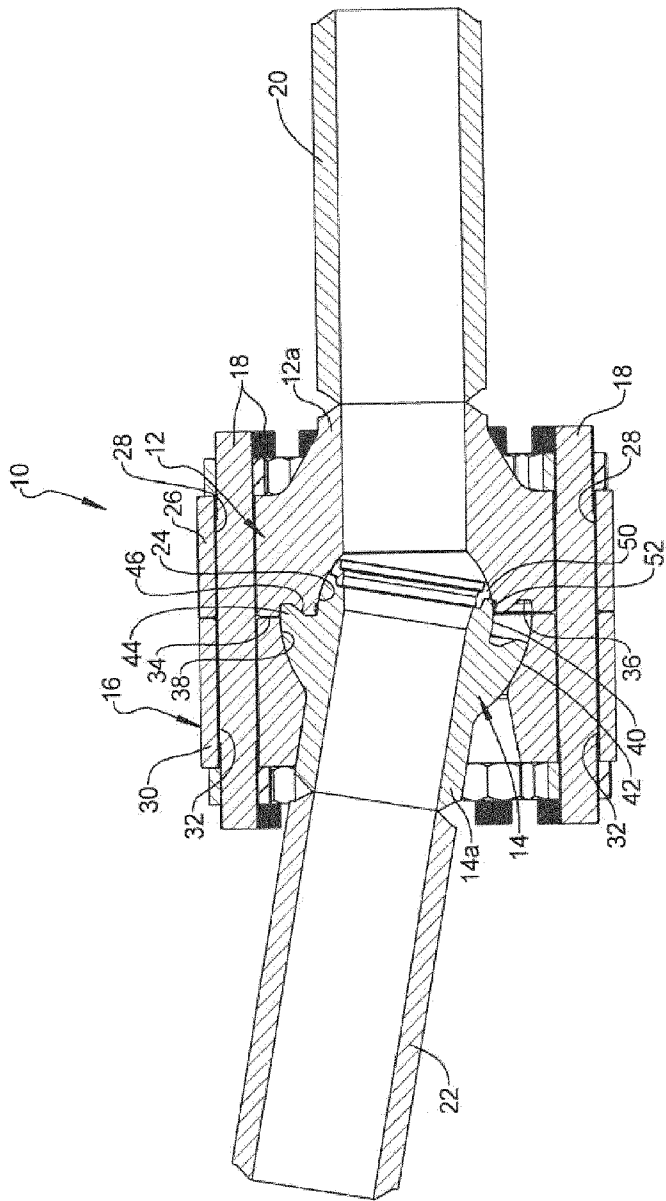

FIG. 2