



INTERNATIONAL APPLICATION PUBLISHED UNDER THE PATENT COOPERATION TREATY (PCT)

<p>(51) International Patent Classification ⁵ : G01N 30/02, 30/48, 30/60 G01N 30/91, B01D 15/08</p>	<p>A1</p>	<p>(11) International Publication Number: WO 93/01494 (43) International Publication Date: 21 January 1993 (21.01.93)</p>
<p>(21) International Application Number: PCT/US92/05768 (22) International Filing Date: 8 July 1992 (08.07.92) (30) Priority data: 729,356 12 July 1991 (12.07.91) US (71) Applicant: TOXI LAB, INC. [US/US]; 2 Goodyear, Irvine, CA 92718 (US). (72) Inventors: O'DONNELL, C., Michael ; 30993 Paseo Valencia, San Juan Capistrano, CA 92675 (US). SCHULTHEIS, Stephen, K. ; 25001 Marin Court, Laguna Hills, CA 92653 (US). (74) Agent: HACKLER, Walter, A.; 2372 S.E. Bristol, Ste. B, Santa Ana Heights, CA 92707 (US).</p>		<p>(81) Designated States: AU, CA, JP, European patent (AT, BE, CH, DE, DK, ES, FR, GB, GR, IT, LU, MC, NL, SE). Published <i>With international search report.</i> <i>With amended claims and statement.</i></p>

(54) Title: METHOD AND APPARATUS FOR IMPROVED SOLID PHASE EXTRACTION

(57) Abstract

A solid phase extraction device (10, 100) for extracting a desired analyte from a sample is disclosed. The device includes an upper cartridge (20, 120) having a fluid inlet (40, 157), a lower cartridge (25, 125) having a fluid outlet (75, 165) in fluid communication with the fluid inlet (40, 157), and at least one concentrator disc (30) positioned intermediate the inlet (40, 157) and the outlet (75, 165). The disc (30) is comprised of silica embedded in a rigid matrix, and has a phase capable of binding the analyte associated therewith. A kit including an extraction device (10, 100) and a chromatographic development sheet (200) is also disclosed. In addition, methods of extracting and storing a desired analyte are disclosed.

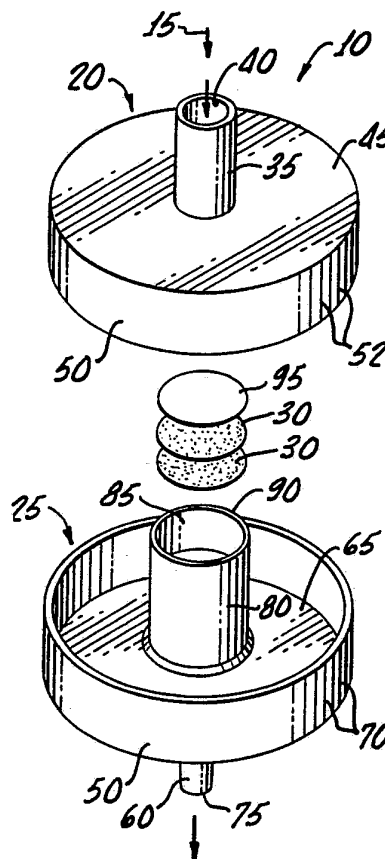

FOR THE PURPOSES OF INFORMATION ONLY

Codes used to identify States party to the PCT on the front pages of pamphlets publishing international applications under the PCT.

AT	Austria	FI	Finland	MI	Mali
AU	Australia	FR	France	MN	Mongolia
BB	Barbados	GA	Gabon	MR	Mauritania
BE	Belgium	GB	United Kingdom	MW	Malawi
BF	Burkina Faso	GN	Guinea	NL	Netherlands
BG	Bulgaria	GR	Greece	NO	Norway
BJ	Benin	HU	Hungary	PL	Poland
BR	Brazil	IE	Ireland	RO	Romania
CA	Canada	IT	Italy	RU	Russian Federation
CF	Central African Republic	JP	Japan	SD	Sudan
CG	Congo	KP	Democratic People's Republic of Korea	SE	Sweden
CH	Switzerland	KR	Republic of Korea	SN	Senegal
CI	Côte d'Ivoire	LI	Liechtenstein	SU	Soviet Union
CM	Cameroon	LK	Sri Lanka	TD	Chad
CS	Czechoslovakia	LU	Luxembourg	TG	Togo
DE	Germany	MC	Monaco	US	United States of America
DK	Denmark	MG	Madagascar		
ES	Spain				

METHOD AND APPARATUS FOR IMPROVED
SOLID PHASE EXTRACTION

BACKGROUND OF THE INVENTION

5

FIELD OF THE INVENTION

The field of the present invention relates to the process of solid phase extraction. More specifically, the present invention relates to the use of a process of solid phase extraction to isolate a specific chemical from a prepared liquid sample. One common application of this process is in the drug screening field.

15

DESCRIPTION OF THE RELATED ART

In conventional solid phase extraction, several steps are required to properly process a sample. For example, the sample to be screened must first be prepared in a liquid form, e.g., by dissolving the sample in a solvent. Next, the liquid is run through a column with loose silica material packed in the bottom. In the typical conventional process, loose silica is suspended in between two porous stops called frits at the base of the column. In order to retain the analyte of interest, the silica must be treated with a phase such as an ion or cation exchange agent to attract specific drugs. A vacuum, positive pressure or a centrifuge is used to aid in passage of the liquid through the bed of silica. Next, the silica is washed several times with an extracting solvent to remove the analyte. Finally, the resulting solution containing the drug is dried out and concentrate. This concentrate is then screened for the presence of

35

the analyte. The concentrate can be used in its solid form or reconstituted depending on the type of screen that is to be performed.

5 Some common screening processes include gas, liquid, or thin layer chromatography. While gas and liquid chromatography are used for quantitative results, they are time intensive and expensive. If only qualitative results are needed, thin film or thin
10 layer chromatography is used because of the simplicity and low cost. The process of thin layer chromatography, as is well known in the art, characterizes analytes based on their ability to migrate in a known medium. An example of this process is disclosed in
15 U.S. Patent No. 3,714,035.

 The foregoing conventional column-based solid phase extraction process uses chemical agents to attract the desired chemical to the silica by forcing
20 the sample to pass through a bed of the treated silica particles. The loose silica must be carefully packed between the frits to insure that the sample, when poured into the column, will pass through the treated particles. If the silica is improperly packed, there
25 is the possibility that small channels will form in between the loose silica fibers. These channels act as passageways of low resistance which allow the liquid to flow through the silica bed without coming into contact with enough of the reagents to pick up
30 sufficient amounts of the analyte. This phenomena is commonly known as channeling and is the main cause of inaccuracy in the solid phase extraction process.

Thus, there exists a need for an improved solid phase extraction process that improves the accuracy of the process.

5

SUMMARY

10

15

20

25

30

35

In accordance with one aspect of the present invention, there is provided a solid phase extraction device for extracting a desired analyte from a sample, comprising an upper cartridge having a fluid inlet, a lower cartridge having a fluid outlet, and at least one concentrator disc positioned intermediate the inlet and the outlet. The fluid outlet is in fluid communication with the fluid inlet. The inlet and the outlet can be provided with luer fittings. The disc is comprised of silica embedded in a rigid matrix, and has associated therewith a phase capable of binding the analyte. Preferably, the rigid matrix comprises a material selected from the group consisting of glass, a crystalline polymer and a non-crystalline polymer. In one embodiment, the phase is an ion exchange resin, including cation exchange resins such as activated silica, sulfonyl and cyanopropyl, and anion exchange resins, such as trimethyl amino propyl.

In one embodiment of the solid phase extraction device of the present invention, the upper and lower cartridges are formed from a single unitary piece. Alternatively, the upper and lower cartridges can be press fit together to substantially prevent removal of the disc by hand. In still another embodiment, the upper and lower cartridges are separable so as to allow removal of the disc for further processing. In this embodiment, the upper and lower cartridges preferably each comprise a handle to facilitate

separation of the cartridges. These handles preferably extend radially symmetrically from the inlet and outlet and comprise ridges to provide additional traction during separation of the cartridges.

5

One preferred phase is an alkyl silane, including C₂, C₈ and C₁₈ alkyl silanes. Other preferred phases include a cation exchange resin, such as sulfonyl and cyanopropyl. The device is preferably provided with a visually discernable code associated with the type of the phase.

10

In an alternative embodiment, the device includes a reservoir in fluid communication with the inlet. This reservoir preferably comprises a filter to substantially prevent undissolved solids from entering the inlet.

15

A vacuum source in connection with the outlet is preferably used with the device. The device can include more than one disc and discs can be treated with different phases. In one embodiment, the disc has a mass under 15 mg. Preferably the disc is comprised of a material sufficiently rigid to be used for thin layer chromatography, such as glass matrix produced from an inert glass membrane dipped in a silica gel.

20

25

The inlet is preferably sized to allow insertion of a conventional piston apparatus. In an alternative embodiment, the upper cartridge is sized for use with a centrifuge tube, and the lower cartridge is sized to hold the disc.

30

The present invention also provides a method of extracting a desired analyte from a fluid sample,

35

comprising the steps of inputting the fluid sample into a solid phase extraction device, contacting the fluid sample with a concentrator disc located inside the extraction device, and binding the analyte to the disc, allowing the substantial part of the fluid component of the sample to pass through the disc. The disc used in this method is comprised of silica embedded in a rigid matrix, and has associated therewith a phase capable of binding the analyte. In one preferred embodiment, the contacting step comprises aspiration of the sample using a vacuum. In another embodiment, the contacting step comprises centrifuging the solid phase extraction concentrator. The method preferably also comprises washing the disc with wash reagents. The inputting step preferably additionally comprises using a piston to input the fluid sample. In one embodiment, the method includes eluting the analyte from the disk. The elution step preferably comprises selecting an elution solvent that will remove the analyte from the disc, and binding the analyte with the elution solvent. The disc resulting from the disc can be dried. Thus, the present invention also provides a method of storing specimens comprising using a preferred method and storing the dried disc produced therefrom. Preferably, the method is performed using a sample, such as urine, whole blood, serum, saliva, or other body fluid. The method preferably additionally comprises identifying the disc as related to a particular sample, and transferring the disc while ensuring the chain of custody when the disc is transferred.

A chromatographic detection kit for detecting a desired analyte from a fluid sample is also provided. This kit comprises a solid phase extraction device

having a fluid inlet and a fluid outlet, at least one
concentrator disc positioned intermediate the inlet
and the outlet, and a chromatographic development
sheet of the same material as the disc. The sheet has
5 a sample space thereon sized and shaped to accept the
disc. The disc is of a material comprised of silica
embedded in a rigid matrix. Preferably, the disc
comprises a phase for binding the analyte.

10 In another aspect of the present invention, there
is provided a method of performing thin layer chroma-
tography to detect the presence of a desired analyte
in a fluid sample, comprising extracting the analyte
from the sample onto an extraction concentrator disc
15 by inputting the sample into a fluid inlet of a solid
phase extraction device having the disc positioned
therein, the disc being of a material comprised of
silica embedded in a glass matrix, inoculating the
disc having the extracted sample thereon into a sample
20 space on a thin layer chromatography sheet of the same
material as the disc, developing the thin layer chro-
matography sheet using a developing solution which
will migrate along the sheet, so as to differentiate
the analyte from other components in the sample based
25 on the analyte's ability to migrate through the sheet
as the developing solution migrates along the sheet,
and detecting the analyte as a spot on the sheet. The
detecting step preferably additionally comprises iden-
tifying the spot by a color reaction and/or identify-
30 ing the spot under UV light. The extracting step
preferably comprises extracting the sample onto a disc
treated with a phase capable of binding the analyte.

BRIEF DESCRIPTION OF THE DRAWINGS

5 Figure 1 is a perspective view of an assembled apparatus of the preferred embodiment of the present invention.

Figure 2 is an exploded view of the apparatus of the preferred embodiment of the present invention.

10 Figure 3 is a cross sectional view of the assembled apparatus of the preferred embodiment of the present invention.

Figure 4 is a perspective view of an assembled apparatus of an alternate embodiment of the present invention.

15 Figure 5 is an exploded view of the apparatus of the alternate embodiment of the present invention.

Figure 6 is a cross sectional view of the assembled apparatus of the alternate embodiment of the present invention.

20 Figure 7 is an exploded perspective view of the thin film chromatographic developing sheet with a concentrator disc aligned with its respective sample space.

DETAILED DESCRIPTION OF THE INVENTION

25

The present invention advantageously provides an apparatus that simplifies the process of solid phase extraction. The present invention also eliminates the channeling effect common in loose particle based extraction methods. Advantageously, the present invention also allows a user thereof to quickly adapt the results of the solid phase extraction to thin layer chromatography in order to identify the analyte while providing means to use the analyte in any other type of identification process.

30

35

5 As described in more detail hereinbelow, the present invention is an apparatus for performing solid phase extraction that uses a concentrator disc made from silica embedded in a rigid matrix instead of the loose silica used in the prior art. The concentrator disc of the present invention has several advantages over the loose silica of the prior art. One advantage is that significantly less silica material is re-
10 quired. Normally between 50 and 100 mg of loose silica is required but each disc of the present invention requires less than 15 mg of silica. Another advantage is that the concentrator disc does not suffer from channeling that may occur in loose silica and therefore provides more accurate test results. Still
15 another advantage is that the disc may immediately be placed in a thin layer chromatographic plate which eliminates the need for several steps of the conventional solid phase extraction processes.

20 The disc is made from a medium that is rigid enough to be placed in the apparatus used for the standard thin layer chromatographic process. In the conventional solid phase extraction, once the analyte of interest is bound to the loose silica, the analyte
25 must be eluted off. The elution process, as is well known in the art, involves several steps: washing the silica several times with a specific reagent to remove the analyte; drying down the eluted solution; concentrating the resultant; and then reconstituting the
30 solid so that it can be spotted on the thin layer chromatographic medium. In contrast, the method and apparatus of the present invention remove the need for several of these steps, as the disc can be removed from the apparatus of the present invention, dried and

then placed directly into the thin layer chromatography apparatus.

5 Although the discs are designed to facilitate the thin layer chromatographic process, they may be treated like loose silica in the conventional solid phase extraction process. The analyte can be eluted as well known in the art, for processing by liquid or gas chromatography.

10 Another advantage of the present invention is that multiple discs may be placed in the apparatus. Each collects a portion of the sample and can be used individually to perform a different screening process.
15 For example, one disc can be used in a thin layer screen while the others can be prepared for liquid or gas chromatography screens. Alternatively, depending on the sample that is being screened, each disc can be treated with a different phase to try to detect the
20 presences of multiple types of drugs while only requiring one decanting. Further, while some drugs are stable, the samples that they come from are often unstable, e.g., urine. Such analytes can be preserved by extracting them from the sample onto the concen-
25 trator discs and then drying and storing the discs for later testing.

Improved Solid Phase Extraction Device

30 Referring now to the drawings in detail, wherein like referenced numerals refer to like features in each of the Figures, there is shown generally at 10 in Figure 1 one preferred embodiment of the solid phase extraction device of the present invention. This
35 embodiment comprises a two-piece unit that when

5 assembled forms a hollow drum shaped unit with a centrally located cylindrical passage 15. As best seen in Figure 2, in the preferred embodiment, the upper cartridge 20 and lower cartridge 25 are separable to allow for insertion and removal of one or more concentrator discs 30. These discs 30 are described in greater detail hereinbelow.

10 Referring to Figures 1-3, the upper cartridge 20 preferably comprises a fluid inlet piece 35, a central passage 15, and an annular portion 45. The annular portion serves as a handle 50 for manipulation of the device as a whole and for removing the upper cartridge 20 from the lower cartridge 25, as will be described below. The fluid inlet piece 35 defines a fluid inlet 15 through which the sample can be introduced into the device 10. The central passage 15 through the upper cartridge 20 preferably comprises two concentrically aligned passages: the fluid inlet piece 35 and an interior passage tube 55. The fluid inlet piece 35 and the upper interior passage tube 55 are concentrically aligned with each other and with the annular portion 45. The fluid inlet piece 35 extends perpendicularly from an upper surface 47 of the annular portion 45, and is preferably sized to allow insertion of a conventional piston nozzle of a syringe. In addition, the fluid inlet piece 35 can be provided with conventional luer fittings to provide for a solid connection with various types of input apparatuses.

25 30 The lower cartridge 25 preferably comprises a fluid outlet piece 60, a central passage 15, and a lower annular portion 65, also defining a handle 50, as described above. The fluid outlet piece 60 defines a fluid outlet 75 through which the extracted sample

35

can exit the device 10. The central passage 15 is concentrically aligned with the annular portion 65 and is preferably comprised of two concentrically aligned passages: the lower interior passage tube 80 and the fluid outlet piece 60. The fluid outlet 75 is in fluid communication with the fluid inlet 40 of the upper cartridge 20 through the central passage 15. The lower interior passage tube 80 extends perpendicularly from the top surface 67 of the annular portion 65, and contains an inner shoulder 85 located approximately a third of the way from a top surface 90 of the lower interior passage 80. The fluid outlet piece 60 extends perpendicularly from a lower surface 68 of the annular portion 65. The fluid outlet piece 60 has a significantly smaller diameter than the lower interior passage 80 and tapers slightly to enable the use of a conventional vacuum apparatus. In certain embodiments of the invention, the outlet piece 60 is provided with standard luer fittings to provide for a solid connection with various types of receiving apparatuses.

As described previously, the upper cartridge 20 and lower cartridge 25 are preferably each provided with a handle 50 for facilitating the manipulation, assembly, and separation of the two cartridges. In the preferred embodiment, each handle 50 is provided with a plurality of traction ridges 52 that are oriented in parallel with the central passageway 15 and extend from the edge of the annular portions 45, 65 to the rim of the handle 50 itself. The traction ridges 52 provide for grippability when the upper cartridge 20 and lower cartridge 25 are separated or assembled. The handles 50 extend radially symmetrically from the fluid inlet 40 and the fluid outlet 75. In the upper cartridge 20, the handle 50 extends

5 from the annular portion 45 in a generally parallel direction to the upper interior passage tube 55. In the lower cartridge 25, the handle 50 extends from the annular portion 65 in a generally parallel direction to the lower interior passage tube 80.

10 In one embodiment of the present invention, both the upper cartridge 20 and lower 25 cartridges are formed from a single unitary piece, but in the preferred embodiment, as illustrated in Figures 1-3, the upper and lower cartridges are two separate pieces. To assemble the preferred embodiment of the invention, one or more concentrator discs 30 are placed within the lower interior passage tube 80 and are oriented
15 parallel to the top surface 67 of the annular portion 65. The first concentrator disc 30 is inserted until it abuts the interior shoulder 85 of the lower interior passage tube 80. Additional discs 30 can be inserted with the same orientation as described above and are placed adjacent to each other. In the preferred embodiment, sufficient space is provided to allow for the placement of three discs 30 and/or
20 filter units 95.

25 If desired, a filter unit 95 may be placed above the concentrator discs 30 to prevent undesired large particles from coming into contact with the concentrator discs 30. The upper cartridge 20 is mated with the lower cartridge 25 about the concentrically
30 aligned central passage 15. The upper interior passage tube 55 fits within the lower interior passage tube 80 and the upper cartridge 20 and the lower cartridge 25 are squeezed together with the two handles 50 moving towards each other. The two cartridges
35 20 and 25 are preferably assembled tightly so

that a bottom surface 97 of the upper interior passage tube 55 is pressing the concentrator discs 30 and optional filter 95 against the inner shoulder 85 of the lower interior passage tube 80. This helps to drain the sample out of the concentrator discs 30 as well as ensure that the entire central passage 15 is properly sealed to prevent leakage. Any number of concentrator discs 30 and filters 95 may be installed, so long as the seal is maintained. Upon completion of the assembly, the central passage 15 should be properly sealed as described above, the handles 50 are located proximate to each other, and the hollow drum-like shape of the unit has been achieved.

In one embodiment, the upper interior passage tube 55 and the lower interior passage tube 55 are provided with a series of concentric receiving and engaging ridges. The ridges are aligned so that the upper cartridge 20 and lower cartridge 25 can be press fit together, to prevent the removal of the concentrator discs 30 from the unit. This embodiment does not have the traction ridges 52 all around the handle 50 of the cartridges as the upper cartridge 20 and lower cartridge 25 need not be separated. Instead, this embodiment has these traction ridges 52 in enough locations on the handle 50 to provide for improved traction, so that the cartridge will not slip out of the hands of the user.

As illustrated in Figures 4-6, an alternative embodiment 100 is provided to allow for use with multiple sizes of centrifuge tubes. This embodiment comprises an inner passageway 110 through an upper cartridge 120 and a lower cartridge 125 with a disc 30 held therebetween. Preferably, this embodiment also

includes a hollow cylindrical column 130 with two ends, with one end being covered with a filter 135 for keeping undesired large particles suspended in the sample as they pass through the passageway 110. The
5 column 130 extends to a larger diameter at its upper portion 140 and has an outer extending shoulder 145 at its edge. The upper portion 140 is open at its end, thereby providing a fluid inlet 150. The upper portion 140 is sized to provide an interference fit
10 with the rim of a standard 50 ml centrifuge tube. The shoulder 145 preferably extends beyond the rim of the centrifuge tube in order to keep the device 100 in the upper portion of a standard centrifuge tube. The column 130 provides a reservoir for approximately 5 ml
15 of the unfiltered sample used in the solid phase extraction method of the present invention.

The upper cartridge 120 comprises a hollow cylinder 157 having a diameter sized to allow inser-
20 tion of the column 130. The hollow cylinder 157 serves as a fluid inlet for the upper cartridge 120. This hollow cylinder 157 tapers to form a smaller cylinder 158 sized to fit within an upper cylinder 159 of the lower cartridge 125. The upper cylinder 159 of
25 the lower cartridge 125 is sized to hold the concentrator discs 30. The discs 30 are placed in parallel alignment with an inner shoulder 162 of the lower cartridge 125 as it tapers to form a fluid outlet 165. The smaller cylinder 158 of the upper cartridge 120 is
30 sized to provide for an interference fit with a standard small centrifuge tube, such that the cylinder 158 can hold a substantial portion of the upper cartridge 120 above the centrifuge tube while the lower cartridge 125 is suspended inside the tube.

35

Thus, the alternate embodiment 100 can be assembled as follows: the concentrator discs 30 are placed within the lower cartridge 125, the upper cartridge 20 is placed within the lower cartridge 125 such that smaller cylinder 158 of the upper cartridge 120 squeezes the concentrator discs 30 against the inner shoulder 162 of the lower cartridge 125 and thereby seals the inner passageway 110 with the lower cartridge 125; finally, the column 130 complete with filter 135 is placed within the upper cartridge 120 to complete the inner passageway 110 and maintain a proper seal.

Concentrator Discs

Referring back to Figures 1-3 of the preferred embodiment of the solid phase extraction device 10 of the present invention, the device 10 comprises one or more concentrator discs 30. The discs 30 are comprised of silica embedded in a rigid matrix. For reasons which will be made apparent hereinbelow, it is preferable that the matrix be sufficiently rigid that the sheets made of the same material as the discs can be used in conventional thin layer chromatography. Thus, preferred matrix materials include glass, crystalline polymers, such as acrylic, and non-crystalline polymers. In the preferred embodiment, silica is embedded in glass by dipping raw glass fiber paper into a concentrated sodium silicate solution and it is immersed in an ammonium chloride solution to gel. The paper is then dried, water rinsed and dried again. The silica embedded paper is shaped into a specifically sized disc depending on the required absorbency of the disc. The amount of silica provided in each disc will depend on the analyte being tested, the

concentration of the analyte, the molecular weight of the analyte and its affinity for the phase. Thus, greater amounts of silica are needed for analytes in low concentration in the sample, of high molecular weight or having low affinity for the phase. Generally, the disc will have an amount of silica in the range of 1.5 to 15 mg. In one embodiment, each disc 30 has approximately 1.5 to 2.0 mg of silica embedded in a glass matrix.

10 The concentrator discs 30 of the present invention that are made from silica embedded in a glass matrix advantageously provide silica in a form that is not loose as is common in the prior art. The silica on the concentrator discs 30 is held in place in the glass matrix, so there are no areas where channels can form, as is common in loose silica. When the sample is poured through the concentrator discs 30 of the present invention, there is always a resistive layer embedded with silica for the analyte to bind. As the silica embedded in the glass matrix does not suffer from channeling problems common in loose silica, the concentrator disc 30 itself provides for the more accurate extraction process of the present invention. Using the preferred size of the concentrator discs 30, approximately 1.5-2.0 mg of silica per disc 30, enables multiple concentrator discs 30 to be placed in the apparatus of the present invention. Each disc 30 can then be used for a different screening process, for storing the analyte or for repeat testing. In addition each disc 30 can be doped with a different phase in order to extract different analytes onto different discs from the same sample. In certain embodiments, the same disc 30 can be doped with more than one phase.

As noted above, the concentrator discs 30 of the present invention are preferably doped with a phase that will attract a desired analyte. There are many different types of phases available, as will be known to those with ordinary skill in the art. If a desired analyte is non-polar, then an alkyl silane phase may be used, such as a C2, C8, or C18 silane. In general, for highly non-polar analytes, shorter chain silanes are preferable in order to allow for elution of the analyte from the phase. For desired analytes of intermediate polarity, a cyclohexyl (CH) phase can be chosen. Additionally, a phenyl phase can be used which provides a different selectivity due to its aromaticity.

In addition, there are many anionic and cationic phases that rely on the properties of ionic bonding to attract the analyte. A variety of such phases will be known to those of ordinary skill in the art. An example of a strong anionic phase is trimethyl amino propyl. An example of a strong cationic phase, or cationic resin, is sulfonyl. In addition, there are weaker cation exchange phases such as cyanopropyl (CN) and activated silica. Use of the weaker ion exchange phases is appropriate for strongly ionic analytes, which would be difficult to elute from the strong ion exchange phases.

There are many techniques which will be known to those of ordinary skill in the art to dope the silica particles of the discs with the phase. As an example of a doping process, silica embedded paper is doped with C18 as follows: The silica paper is dipped in a 5% solution of octadecyl (C18) silane, rinsed in toluene and then dried. In order to dope the silica

paper with a cationic phase such as sulfonyl, the silica paper is dipped in a 5% solution of 2(4-cholorosulfonylphenyl) ethyl trichlorosilane/toluene solution, rinsed in methanol, dipped in a sodium bicarbonate solution and then dried. Doping the silica paper with other solutions may require slightly different processes, but the two illustrated examples are considered the best mode solutions. In order to distinguish which units of the solid phase extraction devices of the present invention 10 contain discs 30 doped with which phase, the devices 10 are coded with a visually discernable marking, preferably using a color code, to indicate what phases are contained within each apparatus. Thus, for example, devices employing discs treated with a cationic exchange resin can be constructed from blue plastic.

Method of Extracting a Desired Analyte

Referring generally to Figures 1-3, the preferred method of extracting the desired analyte will be described. The sample to be tested is first poured into the fluid inlet 40. If desired, the sample can be forced through the inlet 40 by a piston, such as that of a syringe. Next, the fluid sample will pass through the passage 15 of the upper cartridge 20, through a filter 95, if present, and then come into contact with at least one concentrator disc 30. Preferably, the disc 30 will be comprised of silica embedded in a rigid matrix, such as a glass matrix, and will be doped with a phase capable of binding the desired analyte. The desired analyte will be bound to the concentrator disc 30 and the remainder of the sample will pass through the disc 30 and out the fluid outlet 75. In order to improve the accuracy of the

solid phase extraction process, the fluid may be aspirated through the unit by attaching a conventional vacuum apparatus to the fluid outlet piece 60. Additionally, the fluid may be forced through the concentrator discs 30 in the apparatus of the alternative embodiment 100 illustrated in Figures 4-6 by using the forces of a centrifuge.

Referring back to Figures 1-3, after the sample passes through the concentrator discs 30 by any method of the present invention, a small amount of wash reagent, approximately 1 ml, is preferably used to wash the discs 30 to remove foreign material not bound to the phase. The wash reagent is a solvent which will not elute the analyte off the phase yet will still remove unbound foreign material. For many combinations of phase and analyte, distilled water can be used as a wash reagent. Those of ordinary skill in the art will know of other wash reagents for other combinations of phases and analytes.

Once the concentrator disc 30 has extracted the desired analyte, the discs 30 may be removed from the solid phase extraction device for further screening, or the analyte can be eluted from the disc 30 using an elution solvent which will remove the analyte from the disc 30.

If the elution process is used to remove the analyte from the concentrator discs 30, no direct access to the discs 30 is required. Therefore, if embodiment 10 is used, the upper and lower cartridges 20, 25 need not be opened as the discs 30 can remain in the apparatus 10. The elution process requires that the discs 30 be washed with a solvent to remove

the analyte from the phase that bound it to the concentrator disc. The solvent is poured into the fluid inlet 40 and the solution that exits the fluid outlet 75 will contain the analyte that has been removed from the concentrator discs 30. The solvent is chosen based on the analyte of interest and the phase that the disc 30 was doped with.

Referring now to Figures 4-6 of the alternate embodiment 100 of the present invention, the preferred use of this embodiment 100 requires some variations in the method described above in connection with the embodiment of Figures 1-3. After the analyte is bound to the disc, the column 130 is removed which automatically removes the filter 135. Next, the analyte can be eluted from the discs 30 or the disc 30 removed for further processing. The remaining upper cartridge 120 and lower cartridge 125 can be balanced on a smaller centrifuge tube while the elution solvent is poured into the disc retainer portion 155 of the upper cartridge 120. The elution solution is pulled through the concentrator discs 30 and then through the fluid outlet 165 in the lower cartridge 125. Preferably this process is aided by the forces of the centrifuge. The solution containing the analyte is captured in the centrifuge tube, and can then be dried. The dried analyte can then be processed in several different ways depending on the type of screen required.

As discussed above, the analyte is removed from the disk using an elution solvent. Whether this elution solvent is used for removal of the analyte from the disc for further screening or whether the solvent is used to chromatograph the analyte directly from the disc, such as through thin layer chroma-

5 tography (TLC) in the kit described hereinbelow, many
of the same considerations for selection of the
solvent apply. The combination of elution solvent and
phase on the disc can be used to select for desired
analytes, in a manner which will be known to those of
ordinary skill in the art. In order to elute a
desired analyte, the analyte should have a higher
affinity for the elution solvent than for the phase.
For example, highly non-polar molecules will bind very
10 tightly to long chain alkyl silane, such as C18
phases. Thus, to extract a mildly non-polar analyte,
a C18 phase can be used with a methanol/acetone
solvent. When this combination of phase and solvent
is used, highly non-polar contaminants will remain
15 bound to the phase and the desired moderately non-
polar analyte will be eluted. On the other hand, if
the analyte is highly non-polar, a C2 alkyl silane
phase would be more appropriate. A methanol/acetone
solvent would be expected to readily elute the more
20 non-polar analyte from the C2 phase, but not from the
C18 phase. Similarly, when using ion exchange phases,
strong ion exchange phases would be more appropriate
for analytes which are weak ions, with elution using
a solution of a strong counter ion. Weak ion exchange
25 phases would be more appropriate for strongly ionic
analytes. There are several variables associated with
the extraction and elution solutions used in conjunc-
tion with the method of the present invention. The
phases, elution solutions and their combinations
30 listed above are intended to be exemplary and are by
no means exhaustive. As is well known in the art, and
disclosed in "Solvent Extraction Technology" by K.C.
Hormen (1985), available from Analytichem, Division of
Varian Associates of Harbor City, California (the
35 disclosure of which is hereby incorporated by refer-

ence), the specific extraction solutions chosen can affect the accuracy of the solid phase extraction process.

5 In a preferred method of the present invention, whether obtained from embodiment 10 or embodiment 100, the concentrator disc 30 can be removed from the apparatus and dried. The dried disc may be stored or used for a variety of screening processes. Many
10 samples, particularly urine, can be unstable and will break down over time. Thus, it is advantageous to extract the analyte of interest from the sample as the analytes are often more stable than the sample. First, referring to Figures 1-3 of the preferred
15 embodiment of the apparatus of the present invention 10, the apparatus 10 can be used in the improved method of solid phase extraction described above to capture the analyte of interest onto one or more concentrator discs 30. The apparatus is then opened,
20 by separating the upper cartridge 20 and the lower cartridge 25, and one or more of the discs 30 can be removed and dried. The discs 30 containing the desired analyte can then be identified by relating the disc to the sample from which it was extracted.
25 Preferably the disc 30 can be marked directly or can be placed within a marked container to associate the analyte with the sample from which it was extracted. The concentrator disc 30 can be stored as evidence or it can be stored for further testing at a later date.
30 As the disc 30 can be transferred or stored in other locations, a chain of custody can be maintained to ensure the origin of the disc 30 for use as evidence of the origin of the sample stored on the disc 30.

The Chromatographic Detection Kit and Method of Use

5 In order to detect a desired analyte from a fluid
sample, a chromatographic detection kit of the present
invention can be used. The chromatographic detection
kit includes a solid phase extraction device, such as
that illustrated in Figures 1-3 or in Figures 4-6.
The device of the kit includes a fluid inlet 40 and a
fluid outlet 75 and at least one concentrator disc 30
10 of a material comprised of silica embedded in a rigid
matrix. The kit includes a chromatographic sheet 200,
as illustrated in Figure 7. The sheet 200 is
comprised of the same material as the concentrator
disc 30, and has a sample space 210 sized and shaped
15 to receive the disc 30 from the device. The disc 30
is preferably comprised of a glass matrix that is
rigid enough to be used for thin layer chromatography,
although other rigid materials can also be used. The
disc is doped with a phase to bind a desired analyte.

20

The desired analyte is extracted from the sample
by pouring the sample into the fluid inlet 40 of the
solid phase extraction device, allowing it to come
into contact with the concentrator disc 30. The
25 concentrator disc 30 is treated with a phase that will
bind with the analyte of interest and allow other
materials, including most of the fluid component of
the sample, to pass through the fluid outlet 75. Once
the disc has extracted the selected analyte, the disc
30 is removed, such as by separating the upper 20 and
lower cartridges 25. The disc can then be dried or
can be immediately placed into the specifically sized
sample space 210 of thin layer chromatography
development sheet 200 in order to identify the analyte
35 of interest. The thin layer detection process

comprises developing the thin layer chromatographic sheet 200 with a developing solution that will migrate along the sheet and the analyte of interest will migrate along with the solution. The developing solution must be selected as discussed above, to ensure that the analyte is eluted from the phase. The characteristics of the analyte can be determined by its ability to migrate along the thin layer medium in the developing solution. The desired analyte can be detected as a spot on the developing sheet 200 having the appropriate characteristics. As will be recognized by those of ordinary skill in the art, many other identification procedures can then be readily employed. For example, the thin layer chromatographic developing sheet 200 can be placed under ultraviolet (UV) light and the analyte can be determined by its color change under the light. Further the thin film chromatographic developing sheet 200 can be dipped in water or a staining solution and based on the color change of the developing paper 200, the analyte can be identified. Of course, any combination of methods can be used to determine the identity of a given analyte, with more testing providing more accurate results.

Although the invention has been described with reference to specific embodiments, the description is intended to be illustrative of the invention and is not intended to be limiting. Various modifications and applications may occur to those skilled in the art without departing from the true spirit and scope of the invention as defined in the appended claims.

WE CLAIM:

1. A solid phase extraction device for extracting a desired analyte from a sample, comprising:

5 an upper cartridge having a fluid inlet;

a lower cartridge having a fluid outlet, said fluid outlet being in fluid communication with said fluid inlet; and

10 at least one concentrator disc positioned intermediate said inlet and said outlet, said disc being comprised of silica embedded in a rigid matrix, and having associated therewith a phase capable of binding said analyte.

2. The device of Claim 1, wherein said rigid matrix comprises a material selected from the group consisting of glass, a crystalline polymer and a non-crystalline polymer.

3. The device of Claim 1, wherein said upper and lower cartridges are formed from a single unitary piece.

4. The device of Claim 1, wherein said upper and lower cartridges are press fit together to substantially prevent removal of the disc by hand.

5. The device of Claim 1, wherein said upper and lower cartridges are separable so as to allow removal of the disc for further processing.

6. The device of Claim 5, wherein said upper and lower cartridges each comprise a handle to facilitate separation of said cartridges.

7. The device of Claim 6, wherein said handles extend radially symmetrically from said inlet and outlet.

8. The device of Claim 6, wherein said handles comprise ridges to provide additional traction during separation of said cartridges.

9. The device of Claim 1, wherein said inlet and said outlet are provided with luer fittings.

10. The device of Claim 1, wherein said phase is an alkyl silane.

11. The device of Claim 1, wherein said phase is selected from the group consisting of C₂, C₈ and C₁₈ alkyl silanes.

12. The device of Claim 1, wherein said phase is an ion exchange resin.

13. The device of Claim 12, wherein said phase is a cation exchange resin.

14. The device of Claim 13, wherein said phase is selected from the group consisting of activated silica, sulfonyl and cyanopropyl.

15. The device of Claim 12, wherein said phase is an anion exchange resin.

16. The device of Claim 15, wherein said phase comprises trimethyl amino propyl.

17. The device of Claim 1, wherein said disc has associated therewith a plurality of phases.

18. The device of Claim 1, additionally comprising a visually discernable code associated with the type of said phase.

19. The device of Claim 1, additionally comprising a reservoir in fluid communication with said inlet.

20. The device of Claim 19, wherein said reservoir comprises a filter to substantially prevent undissolved solids from entering said inlet.

21. The device of Claim 1, additionally comprising a vacuum source in connection with said outlet.

22. The device of Claim 1, comprising at least two discs.

23. The device of Claim 22, wherein at least one of said discs is treated with a different phase than another one of said discs.

24. The device of Claim 1, wherein said disc has a mass under 15 mg.

25. The device of Claim 1, wherein the disc is comprised of a material sufficiently rigid to be used for thin layer chromatography.

26. The device of Claim 25, wherein said disc is produced from an inert glass membrane dipped in a silica gel.

27. The device of Claim 1, wherein said inlet is sized to allow insertion of a conventional piston apparatus.

28. The device of Claim 1, wherein said upper cartridge is sized for use with a centrifuge tube, and said lower cartridge is sized to hold said disc.

29. A method of extracting a desired analyte from a fluid sample, comprising the steps of:

inputting said fluid sample into a solid phase extraction device;

5 contacting said fluid sample with a concentrator disc located inside said extraction device, said disc being comprised of silica embedded in a rigid matrix, and having associated therewith a phase capable of binding said analyte; and

10 binding said analyte to said disc, allowing the substantial part of the fluid component of said sample to pass through said disc.

30. The method of Claim 29, wherein the contacting step comprises aspiration of said sample using a vacuum.

31. The method of Claim 29, wherein the contacting step comprises centrifuging said solid phase extraction concentrator.

32. The method of Claim 29, additionally comprising washing said disc with wash reagents.

33. The method of Claim 29, wherein the inputting step additionally comprises using a piston to input the fluid sample.

34. The method of Claim 29, additionally comprising eluting said analyte from said disc.

35. The method of Claim 34, wherein said elution step comprises selecting an elution solvent that will remove said analyte from said disc; and binding said analyte with said elution solvent.

36. The method of Claim 29, additionally comprising drying said disc.

37. A method of storing specimens comprising the method of Claim 36 and storing the dried disc produced therefrom.

38. The method of Claim 37, wherein said sample comprises urine, whole blood, serum, saliva, or other body fluid.

39. The method of Claim 37, additionally comprising:

identifying the disc as related to a particular sample; and

transferring the disc while ensuring the chain of custody when the disc is transferred.

40. A dried disc produced by the method of Claim 36.

41. A chromatographic detection kit for detecting a desired analyte from a fluid sample, comprising:

5 a solid phase extraction device having a fluid inlet and a fluid outlet;

at least one concentrator disc positioned intermediate said inlet and said outlet, said disc being of a material comprised of silica embedded in a rigid matrix; and

10 a chromatographic development sheet of the same material as said disc, said sheet having a sample space thereon sized and shaped to accept said disc.

42. The kit of Claim 41, wherein said disc comprises a phase for binding said analyte.

43. A method of performing thin layer chromatography to detect the presence of a desired analyte in a fluid sample, comprising:

5 extracting the analyte from said sample onto an extraction concentrator disc by inputting said sample into a fluid inlet of a solid phase extraction device having said disc positioned therein, said disc being of a material comprised of silica embedded in a glass matrix;

10 inoculating said disc having said extracted sample thereon into a sample space on a thin layer chromatography sheet of the same material as said disc;

15 developing said thin layer
 chromatography sheet using a developing
 solution which will migrate along said
 sheet, so as to differentiate said analyte
 from other components in said sample based
20 on the analyte's ability to migrate through
 said sheet as said developing solution
 migrates along said sheet; and
 detecting said analyte as a spot on
 said sheet.

44. The method of Claim 43, wherein said detecting step comprises identifying said spot by a color reaction.

45. The method of Claim 43, wherein said detecting step comprises identifying said spot under UV light.

46. The method of Claim 43, wherein said extracting step comprises extracting said sample onto a disc treated with a phase capable of binding said analyte.

AMENDED CLAIMS

[received by the International Bureau on 27 November 1992 (27.11.92);
original claims 1-42 replaced by amended claims 1-12 (4 pages)]

1. A solid phase extraction device for extracting a desired analyte from a fluid sample, said device comprising:

an upper cartridge having a fluid inlet;
a lower cartridge having a fluid outlet in fluid communication with said fluid inlet;
means positioned intermediate said inlet and said outlet, and including a phase capable of binding said desired analyte, for extracting said desired analyte from a sample passing therethrough; and

means for preventing channeling of said sample through the means for extracting said desired analyte, said means for preventing channeling comprising a solid matrix having silica and said phase imbedded therein.

2. The device of claim 1, wherein said rigid matrix comprises a material selected from the group consisting of glass, a crystalline polymer and a non-crystalline polymer.

3. A manually manipulated extraction device for extracting a desired analyte from a fluid sample comprising:

an upper cartridge having a fluid inlet;
a lower cartridge having a fluid outlet adapted to be removably coupled with said fluid inlet;

means for preventing contact by a user of the extraction device from contacting said sample during extraction of analyte from the sample and during disassembly of the fluid inlet from the fluid outlet, said means for preventing contact comprising an upper cartridge annular portion disposed around said fluid inlet and a lower cartridge annular portion disposed around said fluid outlet, each annular portion including a handle means, defining a perimeter thereon, for facilitating separation of said cartridges;

means, positioned intermediate said inlet and said outlet and including a phase capable of finding said desired analyte, for extracting said desired analyte from a sample passing therethrough; and

means for preventing channeling of said sample through the means for extracting said desired analyte, said means for preventing channeling comprising a solid matrix having silica and said phase imbedded therein.

4. The device of claim 3, wherein said handles extend radially symmetrically from said inlet and outlet.

5. The device of claim 3, wherein said handles comprise ridges to provide additional traction during separation of said cartridges.

6. The device of claim 1, wherein said means for extracting a desired analyte includes a plurality of phases capable of extracting a plurality of analytes.

7. The device of claim 1, additionally comprising a reservoir in fluid communication with said inlet.

8. The device of claim 7, wherein said reservoir comprises a filter to substantially prevent undissolved solids from entering said inlet.

9. The device of claim 1, wherein the solid matrix and silica have a mass less than about 15 mg.

10. The device of claim 1, wherein the disc is comprised of a material sufficiently rigid to be used for thin layer chromatography.

11. A method of extracting a desired analyte from a fluid sample, comprising the steps of:

assembling a solid matrix including a phase capable of binding said desired analyte between a fluid inlet and a fluid outlet;

passing said fluid sample through the solid matrix without channeling of the fluid sample in the solid matrix to enable binding of said desired analyte to said solid matrix and allowing a non-analyte part of the fluid sample to pass through said matrix;

disassembling the solid matrix from the fluid inlet and fluid outlet; and

providing structure surrounding said fluid inlet and outlet for collecting of leaked fluid sample or fluid sample remaining proximate the solid matrix in order to prevent contact with the assembler/disassembler.

12. The method of claim 11, additionally comprising the step of washing said solid matrix with wash reagents before disassembly.

STATEMENT UNDER ARTICLE 19

New claims 1-12 are submitted in lieu of original claims 1-42. The new claims distinguish the invention over the art cited by the Examiner.

FIG. 4.

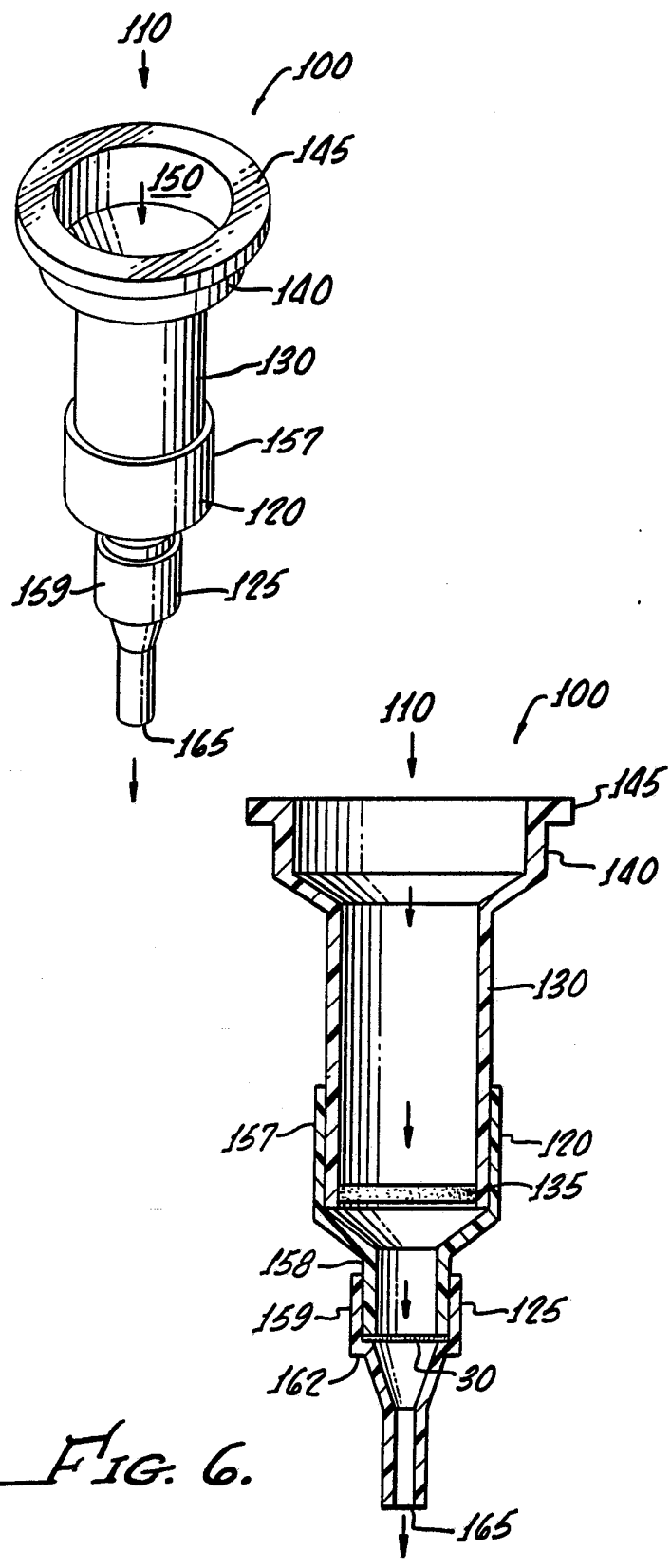

FIG. 6.

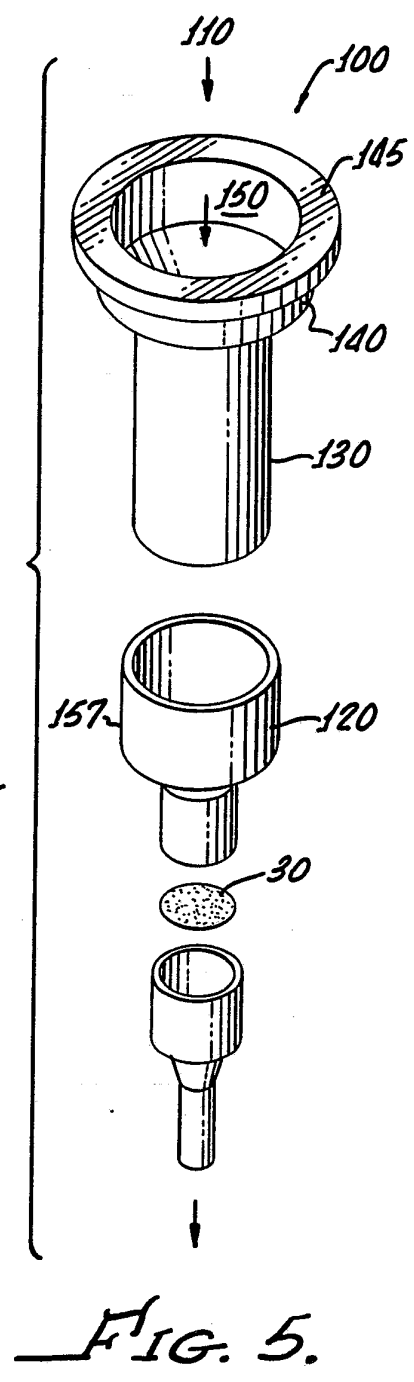

FIG. 5.

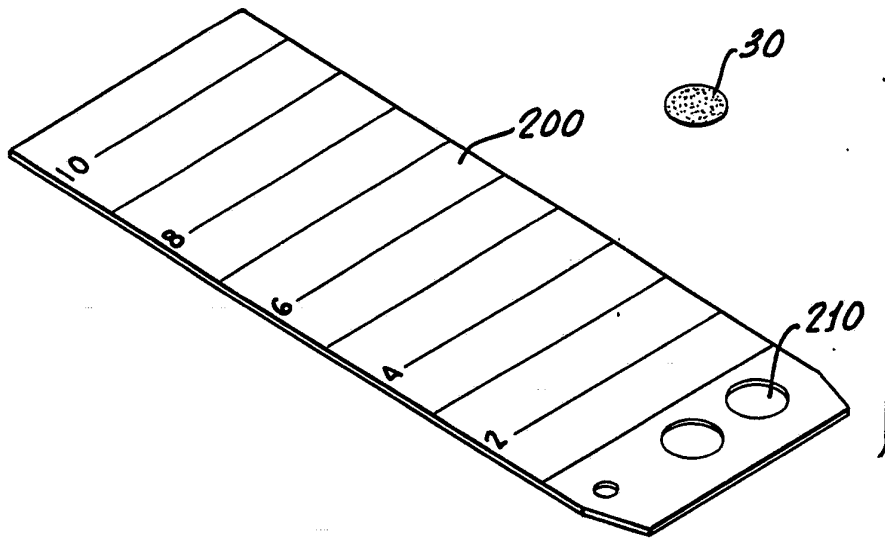

FIG. 7.

INTERNATIONAL SEARCH REPORT

International application No.
PCT/US92/05768

A. CLASSIFICATION OF SUBJECT MATTER

IPC(5) : G01N 30/02, 30/48, 30/60, 30/91; B01D 15/08
US CL : Please See Extra Sheet.

According to International Patent Classification (IPC) or to both national classification and IPC

B. FIELDS SEARCHED

Minimum documentation searched (classification system followed by classification symbols)

U.S. : 422/69, 70, 59, 60, 68.1; 436/ 161, 162; 210/ 656, 658, 198.2, 198.3

Documentation searched other than minimum documentation to the extent that such documents are included in the fields searched
None

Electronic data base consulted during the international search (name of data base and, where practicable, search terms used)
None

C. DOCUMENTS CONSIDERED TO BE RELEVANT

Category*	Citation of document, with indication, where appropriate, of the relevant passages	Relevant to claim No.
Y,P	US, A, 5,124,041 (Sheer et al) 23 June 1992, see column 2, lines 53-57; column 3, lines 12-16; column 4, lines 37-48; column 6, lines 21-42.	1-46
Y	US, A, 3,714,035 (Jones) 30 Jan 1973, see column 1, lines 12-26; column 2, lines 45-47; column 3, lines 35-37.	1-46
Y	US, A, 3,963,421 (Jones) 15 June 1976, see column 5, lines 15-19.	1-46
Y	US, A, 4,961,916 (Lesage et al) 09 October 1990, see column 4, lines 49-66; column 6, line 58 - column 7, line 37.	1-46
Y	US, A, 4,787,971 (Donald) 29 November 1988, see column 6, lines 13-21.	9

Further documents are listed in the continuation of Box C. See patent family annex.

<p>* Special categories of cited documents:</p> <p>"A" document defining the general state of the art which is not considered to be part of particular relevance</p> <p>"E" earlier document published on or after the international filing date</p> <p>"L" document which may throw doubts on priority claim(s) or which is cited to establish the publication date of another citation or other special reason (as specified)</p> <p>"O" document referring to an oral disclosure, use, exhibition or other means</p> <p>"P" document published prior to the international filing date but later than the priority date claimed</p>	<p>"T" later document published after the international filing date or priority date and not in conflict with the application but cited to understand the principle or theory underlying the invention</p> <p>"X" document of particular relevance; the claimed invention cannot be considered novel or cannot be considered to involve an inventive step when the document is taken alone</p> <p>"Y" document of particular relevance; the claimed invention cannot be considered to involve an inventive step when the document is combined with one or more other such documents, such combination being obvious to a person skilled in the art</p> <p>"&" document member of the same patent family</p>
---	---

Date of the actual completion of the international search 27 JULY 1992	Date of mailing of the international search report 14 AUG 1992
---	--

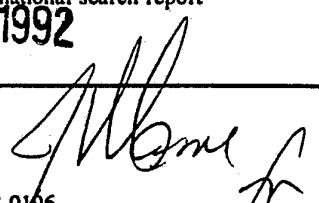
Name and mailing address of the ISA/ Commissioner of Patents and Trademarks Box PCT Washington, D.C. 20231 Facsimile No. NOT APPLICABLE	Authorized officer  STEPHANIE BLYTHE Telephone No. (703) 308-0196
---	---

INTERNATIONAL SEARCH REPORT

International application No.
PCT US92/05768

A. CLASSIFICATION OF SUBJECT MATTER:

US CL :

422/69, 70, 59, 60, 68.1; 436/ 161, 162; 210/ 656, 658, 198.2, 198.3