

June 2, 1970

J. J. DOUGHERTY, JR

3,514,959

PEDESTAL TIMBER PILE SHOE

Filed Sept. 5, 1968

3 Sheets-Sheet 1

Fig. 1



Fig. 3

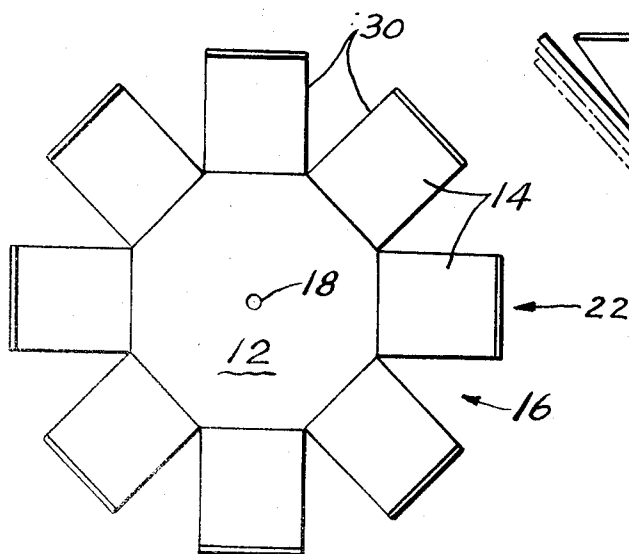
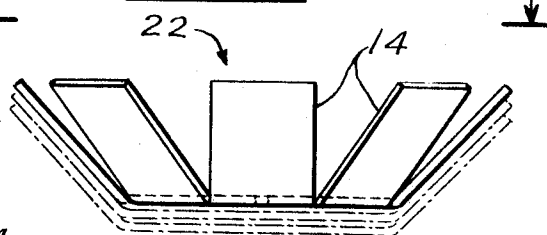

Fig. 2



INVENTOR.
JOHN J. DOUGHERTY, JR.
BY
Edw. S. Higgins
ATTORNEY

June 2, 1970

J. J. DOUGHERTY, JR

3,514,959

PEDESTAL TIMBER PILE SHOE

Filed Sept. 3, 1968

3 Sheets-Sheet 2

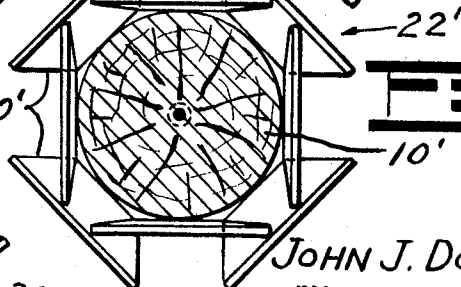
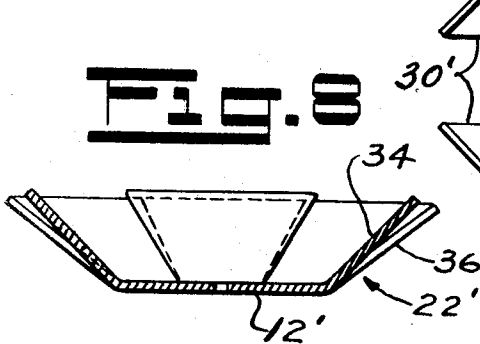
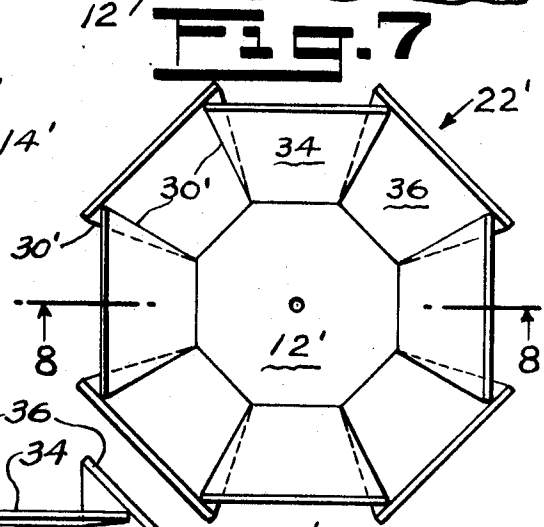
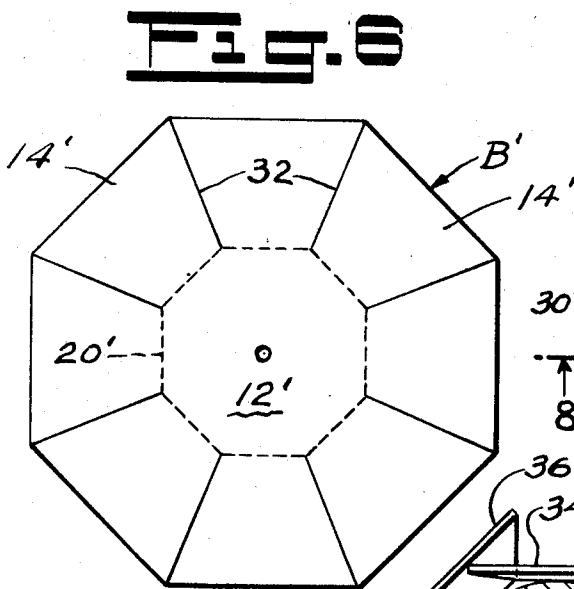
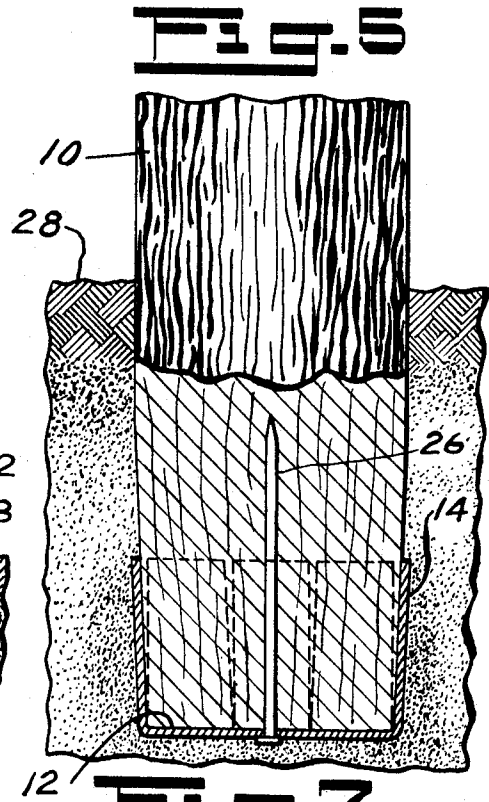
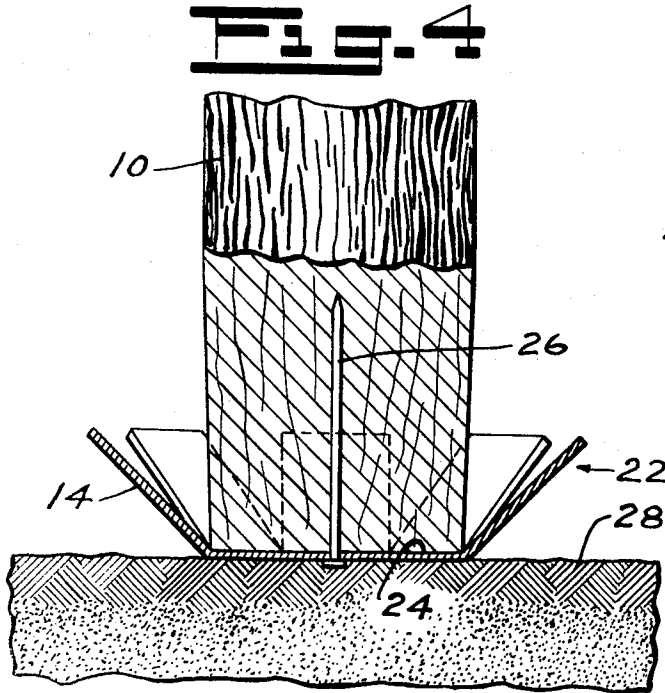

INVENTOR.
JOHN J. DOUGHERTY, JR.
BY
Edw. S. Higgins
ATTORNEY

June 2, 1970

J. J. DOUGHERTY, JR

3,514,959

PEDESTAL TIMBER PILE SHOE

Filed Sept. 3, 1968

3 Sheets-Sheet 3

Fig. 10

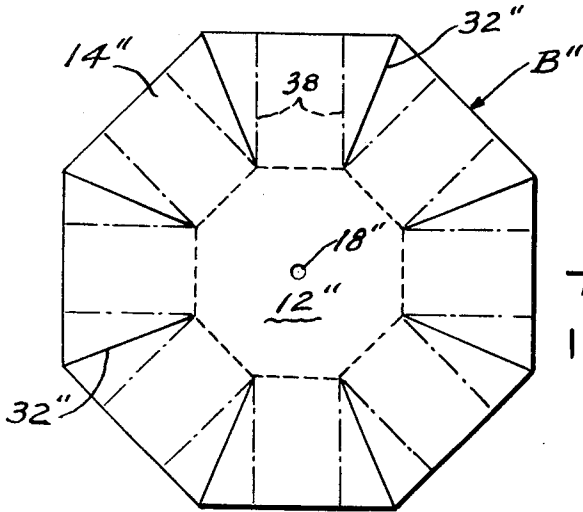

Fig. 11

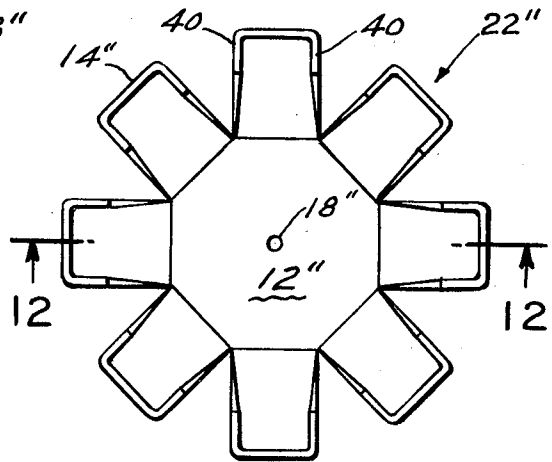

Fig. 13

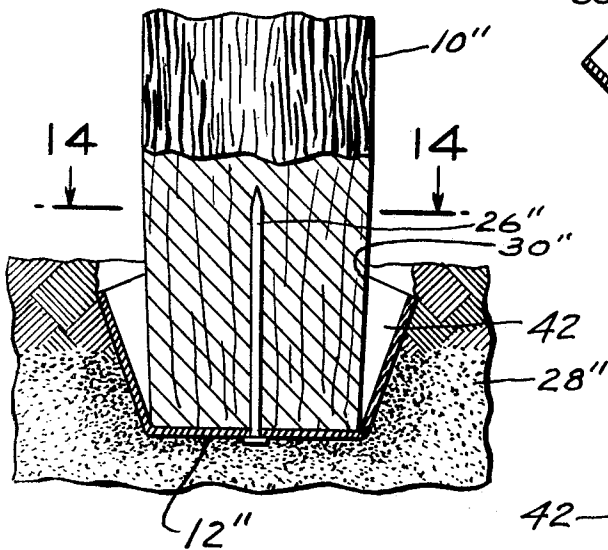

Fig. 12

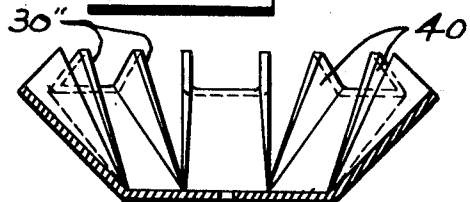
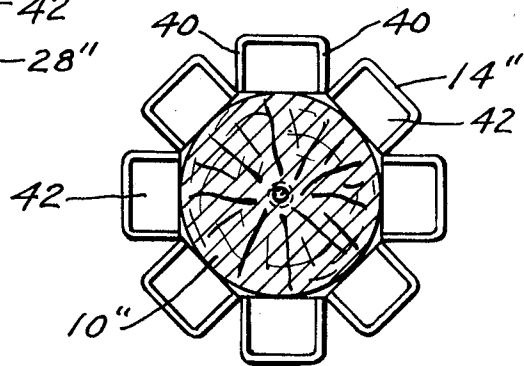

Fig. 14



INVENTOR.

JOHN J. DOUGHERTY, JR

BY

Edw. S. Higgins

ATTORNEY

1

3,514,959

PEDESTAL TIMBER PILE SHOE

John J. Dougherty, Jr., 262 Rutherford Blvd.,
Franklin Lakes, N.J. 07014

Filed Sept. 3, 1968, Ser. No. 756,841

Int. Cl. E02d 5/26

U.S. Cl. 61—53

1 Claim

ABSTRACT OF THE DISCLOSURE

A shoe for the bottom end of a timber pile having a flat body with peripheral radial wings adapted to be bent against the side surface of the timber pile. The flat body has a central hole for receiving a fastening element for fastening the shoe to the pile.

This invention relates generally to piles and more particularly to new and useful improvements in a pedestal timber pile shoe adapted to be driven into layers of coarse sand or gravel and held suspended in the earth.

A principal object of the present invention is to provide a shoe for a timber pile that is easily attached to the pile yet affords effective protection for the penetrating end of the timber pile against splitting, spreading, dog-legging or blooming.

Brief description of the views of the drawings

FIG. 1 is a top plan view of the precut blank from which the shoe is formed.

FIG. 2 is a side elevational view on a reduced scale of the completed shoe, a number of shoes being shown in dash lines in nested position.

FIG. 3 is a top plan view of the shoe of FIG. 2 as seen from the line 3—3 of FIG. 2.

FIG. 4 is a side elevational view of the lower portion of a timber pile having the improved shoe fastened thereto, preparatory to being driven into the ground.

FIG. 5 shows the timber pile and shoe of FIG. 4 driven into the ground.

FIG. 6 is a view similar to FIG. 1 of a blank for a modified form of shoe.

FIG. 7 is a top plan view of the completed shoe of FIG. 6.

FIG. 8 is a cross-sectional view taken on the plane of the line 8—8 of FIG. 7.

FIG. 9 is a cross sectional view through the bottom portion of a timber pile with the shoe of FIG. 7 attached thereto.

FIG. 10 is a view similar to FIG. 1 of a blank for another modified form of shoe.

FIG. 11 is a view similar to FIG. 3 of the shoe formed from the blank of FIG. 10.

FIG. 12 is a cross-sectional view taken on the line 12—12 of FIG. 11.

FIG. 13 is a view similar to FIG. 4 showing the shoe of FIG. 11 fastened to a timber pile.

FIG. 14 is a cross sectional view taken on the lines 14—14 of FIG. 13.

Detailed description of the drawings

Referring in detail to the various views of the drawings, and particularly to FIG. 4 wherein the lower portion of a timber pile 10 is shown with a flat bottom surface 12.

2

In producing pile shoes for application to flat bottomed timber piles 10 a blank B such as shown in FIG. 1 is cut from sheet metal such as steel, for example, of suitable width and thickness. The blank B has a central substantially circular flat body 12 with integral rectangular shaped wings 14 integrally extending radially from the periphery thereof, eight such wings being shown, with V-shaped notches 16 therebetween. A hole 18 is formed in the center of the body 12 for receiving a fastening element.

The wings 14 are suitably initially bent angularly approximately 45 degrees from the plane of the body 12 along fold lines 20 as seen in FIG. 2 forming a completed shoe indicated generally at 22 in FIG. 3.

In use, the shoe 22 is fastened to the flat bottom surface 24 of the timber pile 10 by placing the body 12 of the shoe against the flat bottom surface of the pile and driving a nail or spike 26 through the center hole 18 and material of the pile as shown in FIG. 4.

In operation, the timber pile 10 is driven through the sandy soil or gravel 28 in the usual manner and due to the friction and pressure of the sand or gravel against the wings 14 as the pile is being driven downwardly, the wings are bent farther upwardly until they strike against the side surface of the timber pile as shown in FIG. 5, at which time the edges 30 of the wings will be in abutting or edge to edge relation, the shoe thus protecting the bottom end edge of the timber pile from splitting, blooming and damage from striking rocks and the like.

In FIGS. 6 to 9, inclusive, a modified form of improved shoe 22' is shown formed from a blank B' shown in FIG. 6 which is formed with spaced radial slits 32 extending outwardly from the periphery of the center body 12' defining radial wings 14'. In this form of shoe 12', the wings 14' are initially bent upwardly along the fold lines 20', approximately 45 degrees and every other wing is bent slightly farther than its adjacent wing so that the edges 30' of the wings overlap slightly thus defining a series of inner wings 34 and a series of outer wings 36.

The shoe 22' is applied to the timber pile 10' similarly to shoe 22 and in operation the inner wings 34 are bent flat against the side surface of the timber pile 10' and the outer wings 36 are bent against the adjacent edges 30' of the inner wings as best shown in FIG. 9.

In the modified form of shoe 22'' shown in FIGS. 10 to 14, inclusive, the blank B'' is formed with radial slits 32'' extending outwardly from the periphery of the body 12'', defining wings 14''. Each wing is folded longitudinally along a pair of spaced fold lines 38, 38, defining inwardly extending flanges 40, 40. The wings with the flanges have channel-shaped tapered bodies, with the wide portions of the tapered bodies on the outer ends thereof. The channel-shaped tapered bodies are initially bent upwardly approximately 45 degrees as seen in FIGS. 12 and 14.

The shoe 22'' is applied to the timber pile 10'' in the same manner as shoe 22 and is fastened thereto by the nail 26'' extending through the hole 18'' in the body 12'' of the shoe. When the pile and shoe are driven into the clay soil 28'', the channel-shaped wings 14'' are farther bent by the pressure of the soil against the side surface of the timber pile with the tapered edges 30'' of the flanges 40 of the wings abutting against the side surface of the pile, leaving a space 42 between each wing 14'' and the pile as seen in FIG. 13.

The shoes are readily nested in shipment for economizing space as shown in FIG. 2.

I claim:

1. A timber pile shoe comprising a flat circular sheet steel body with a central hole therein and radial wings extending outwardly from the periphery of the body, said body adapted to be placed flat against the flat bottom and surface of a timber pile, said wings adapted to be bent inwardly against the side surface of the timber pile when the pile is driven into sandy soil, the wings being separately bendable inwardly and being initially bent inwardly at an angle of 45 degrees, each of said wings being bent at right angles to the plane of the body thereof forming diverging sides, said sides constituting tapering flanges, the free edges of the flanges adapted to engage the side surface of the timber pile.

References Cited

UNITED STATES PATENTS

	1,018,979	2/1912	Mast	-----	61—53
	2,102,921	12/1937	Schmitt	-----	61—53
5	2,710,996	6/1955	Pittman	-----	52—301

FOREIGN PATENTS

	3,475	2/1913	Great Britain.
--	-------	--------	----------------

10 JACOB SHAPIRO, Primary Examiner

U.S. Cl. X.R.

52—300