

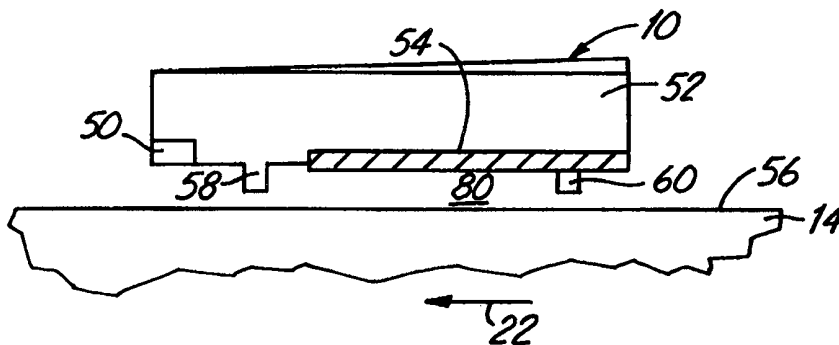

INTERNATIONAL APPLICATION PUBLISHED UNDER THE PATENT COOPERATION TREATY (PCT)

<p>(51) International Patent Classification ⁶ : G11B 5/60, 17/32, 21/21</p>	<p>A1</p>	<p>(11) International Publication Number: WO 99/09547</p> <p>(43) International Publication Date: 25 February 1999 (25.02.99)</p>
<p>(21) International Application Number: PCT/US98/05628</p> <p>(22) International Filing Date: 20 March 1998 (20.03.98)</p> <p>(30) Priority Data: 60/055,740 15 August 1997 (15.08.97) US</p> <p>(71) Applicant (for all designated States except US): SEAGATE TECHNOLOGY, INC. [US/US]; 920 Disc Drive, Scotts Valley, CA 95066 (US).</p> <p>(72) Inventor; and (75) Inventor/Applicant (for US only): BOUTAGHOU, Zine-Eddine [US/US]; 307 Lily Pond Lane, Vadnais Heights, MN 55127 (US).</p> <p>(74) Agents: CHAMPLIN, Judson, K.; Westman, Champlin & Kelly, P.A., International Centre Suite 1600, 900 Second Avenue South, Minneapolis, MN 55402-3319 (US) et al.</p>		<p>(81) Designated States: CN, DE, GB, JP, KR, SG, US.</p> <p>Published <i>With international search report.</i></p>

(54) Title: SLIDER FOR DISC STORAGE SYSTEM



(57) Abstract

A storage device for storing information includes a disc storage medium (14) having a disc surface (56). An armature (12) is positioned over the disc surface (56) and carries a head (50) proximate the disc surface (56). Transducing circuitry (20) is coupled to the head (50) for reading and writing information onto the disc surface (56). A slider (10) is coupled to the armature (12) near an end of the armature (12) for carrying the head (50) and is adapted to position the transducing head proximate the disc surface (56). The slider (10) includes an interface surface facing the disc surface (56) having an air bearing region adapted to form an air bearing (80) with the disc surface (56) and having a contact pad (58, 60, 62, 64, 80) extending from the air bearing region.

FOR THE PURPOSES OF INFORMATION ONLY

Codes used to identify States party to the PCT on the front pages of pamphlets publishing international applications under the PCT.

AL	Albania	ES	Spain	LS	Lesotho	SI	Slovenia
AM	Armenia	FI	Finland	LT	Lithuania	SK	Slovakia
AT	Austria	FR	France	LU	Luxembourg	SN	Senegal
AU	Australia	GA	Gabon	LV	Latvia	SZ	Swaziland
AZ	Azerbaijan	GB	United Kingdom	MC	Monaco	TD	Chad
BA	Bosnia and Herzegovina	GE	Georgia	MD	Republic of Moldova	TG	Togo
BB	Barbados	GH	Ghana	MG	Madagascar	TJ	Tajikistan
BE	Belgium	GN	Guinea	MK	The former Yugoslav Republic of Macedonia	TM	Turkmenistan
BF	Burkina Faso	GR	Greece	ML	Mali	TR	Turkey
BG	Bulgaria	HU	Hungary	MN	Mongolia	TT	Trinidad and Tobago
BJ	Benin	IE	Ireland	MR	Mauritania	UA	Ukraine
BR	Brazil	IL	Israel	MW	Malawi	UG	Uganda
BY	Belarus	IS	Iceland	MX	Mexico	US	United States of America
CA	Canada	IT	Italy	NE	Niger	UZ	Uzbekistan
CF	Central African Republic	JP	Japan	NL	Netherlands	VN	Viet Nam
CG	Congo	KE	Kenya	NO	Norway	YU	Yugoslavia
CH	Switzerland	KG	Kyrgyzstan	NZ	New Zealand	ZW	Zimbabwe
CI	Côte d'Ivoire	KP	Democratic People's Republic of Korea	PL	Poland		
CM	Cameroon	KR	Republic of Korea	PT	Portugal		
CN	China	KZ	Kazakstan	RO	Romania		
CU	Cuba	LC	Saint Lucia	RU	Russian Federation		
CZ	Czech Republic	LI	Liechtenstein	SD	Sudan		
DE	Germany	LK	Sri Lanka	SE	Sweden		
DK	Denmark	LR	Liberia	SG	Singapore		
EE	Estonia						

SLIDER FOR DISC STORAGE SYSTEM

BACKGROUND OF THE INVENTION

The present invention relates to disc storage systems of the type used to store information. More specifically, the invention relates to the interface between slider and a surface of a storage disc.

Magnetic disc drives are used to store magnetically encoded information. As the magnetic disc spins, a transducing head "flies" over the surface of the disc. The transducing head is used to sense magnetic fields from the disc surface during readback of information, and to generate magnetic fields which are impressed onto the surface of the disc during writing of information. As the disc spins, the transducing head is supported by an "air bearing" which is formed between the disc surface and an air bearing slider of the transducer head assembly. The slider body has aerodynamic properties which provide a lifting force.

It is known that improved magnetic interaction between the disc surface and the transducing head can be achieved by reducing the spacing between the head slider and the disc surface. However, as the spacing between slider and disc is reduced, it becomes critical that the fly height be accurately maintained. If the slider should dip slightly, it will touch the surface of the disc and potentially damage the surface. This is particularly problematic with magnetoresistive or magneto-optic recording heads in which contact with an asperity on the disc surface can generate an error in the readback signal.

One technique for achieving very close spacing between the transducing head and the disc surface is described in U.S. Patent No. 5,550,691 which issued

-2-

August 27, 1996 to Hamilton and is entitled "SIZE-INDEPENDENT, RIGID-DISK, MAGNETIC, DIGITAL-INFORMATION STORAGE SYSTEM WITH LOCALIZED READ/WRITE ENHANCEMENTS. The Hamilton reference describes a slider for contact recording in which the surface of the slider is dragged
5 across the disc surface.

SUMMARY OF THE INVENTION

A storage device for storing information includes a disc storage medium having a disc surface.
10 An armature is positioned over the disc surface and carries a magnetoresistive or a magneto-optic head proximate the disc surface. Transducing circuitry is coupled to the head for reading and writing information onto the disc surface. The slider is coupled to the
15 armature near an end of the armature for carrying the head and is adapted to position the head proximate the disc surface. The slider includes an interface surface facing the disc surface having an air bearing region adapted to form an air bearing with the disc surface and
20 having at least one contact pad extending from the air bearing region for contact recording. The air bearing provides an opposed lifting force which, when combined with the contact force on the pad, is substantially equal to the preload force.

25 In one aspect of the invention a sacrificial wear layer is provided on the at least one contact pad. In another aspect of the invention, the contact pad has a height which is at equilibrium with the air bearing during operation of the disc whereby the air bearing
30 forms a shock absorbing cushion for the slider.

-3-

BRIEF DESCRIPTION OF THE DRAWINGS

Figure 1 is a top plan view of a disc storage system having a slider in accordance with the present invention.

5 Figure 2 is a side plan view of a slider in accordance with the present invention.

Figure 3 is a bottom plan view of the slider of Figure 2.

10 Figure 4 is a graph of separation distance between a slider and a disc surface versus lift provided by the slider.

Figure 5 is a simplified diagram showing a geometrical relation between slider pitch, pad position and pad height.

15 Figure 6 shows the fly height distribution of typical sliders.

DETAILED DESCRIPTION OF THE PREFERRED EMBODIMENTS

The present invention provides a new design for a slider for use with a rotating disc storage medium. U.S. Patent No. 5,550,691, issued August 27, 20 1996 to Hamilton shows one prior art technique in which a slider is dragged across the disc surface. The Hamilton patent describes a slider having "feet" which are constructed of a hardened material. A transducing head is embedded within the one of the feet. The load 25 placed on the transducing head by the armature is very low and the slider surface is designed to wear at a very low rate. However, the design is particularly susceptible to vibrations or other impacts which can 30 cause the slider to crash against the disc surface. Further, the design set forth in the Hamilton patent is for a vertical recording device and is not suited for implementation in horizontal recording systems such as those that are currently used with magnetoresistive

-4-

transducing elements. Further still, impact with an asperity will cause an error in readback from the magnetoresistive head.

5 The present invention includes a slider for use with a disc storage medium which includes an air bearing (or a "squeeze film") to achieve a number of advantages over the prior art. The design allows an equilibrium to be reached between the fly height, the preload force and the pad height. This is achieved
10 through wear of the pad. Advantages include a reduction in the sensitivity of the slider to external vibrations or to contact induced excitation. The additional air bearing provides a damping function to vibrations as the slider moves across the disc surface. A slider in
15 accordance with the present invention includes at least one protruding pad which extends from an air bearing surface of the slider.

Figure 1 is a top plan view which illustrates a slider 10 supported by gimbal 11 over a disc 14. Gimbal 11 is secured to arm 12. Arm 12 positions slider
20 10 over individual data tracks on disc 14 (not shown) along an arc 18. As disc 14 rotates, it generates wind or air flow in the direction shown by arrows 16 (wind 16). Wind 16 is approximately parallel to the
25 tangential velocity of the disc as indicated by arrow 22. Wind 16 cooperates with slider 10 to produce lift which pushes slider 10 away from disc 14. Typically, gimbal 11 is a resilient spring that allows slider 10 to follow the topography of disc 14. Gimbal 11 includes a
30 dimple (not shown) that is in point contact with arm 12. The dimple provides a pivot about which slider 10 can pitch and roll following the topography of disc 14. Transducing circuitry couples to a head 50 (magnetoresistive or magneto-optic) on slider 10 for

-5-

reading and writing information on disc 14. The elements described to this point are generally conventional in the design in disc drives.

Figure 2 is a side plan view of slider 10 in accordance with the present invention. Slider 10 includes magnetoresistive or magneto-optic element 50 positioned on a trailing edge of slider 10 which may be any type of transducing element such as a magnetoresistive head or magneto-optical element, etc. Slider 10 also includes main body portion 52 having air bearing surface 54 carried thereon which generally faces surface 56 of disc 14. Slider 10 carries contact or wear pads 58 and 60 in accordance with the invention.

Figure 3 is a bottom plan view of slider 10 which shows wear pads 62 and 64 in addition to pads 58 and 60. Additionally, Figure 3 shows air bearing surface 54 in greater detail. In the example shown, air bearing surface 54 is a multi-step air bearing surface having steps 66, 68 and 70 and is designed for maximum damping effectiveness during operation. However, air bearing surface 54 is shown generally in schematic form and any type of air bearing surface 54 may be employed as the present invention is not limited to the particular embodiment shown. Additionally, any number of pads may be used and their particular shape may be changed as desired. In one preferred embodiment, a single pad 80 may be used and positioned slightly in front of head 50. In one preferred embodiment, pads 58, 60, 62 and 64 are formed of (or coated with) a hard material such as diamond-like carbon (DLC). The air bearing surface 54 may be designed to provide net lift or no net lift, as desired, in order to achieve a given nominal separation which is guaranteed by the height of contact pads 58-64.

-6-

The present invention provides a design in which there is an equilibrium reached between the air bearing, the preload force and the pad height. This ensures that the magnetoresistive head flies as close as possible to the disc without contacting asperities. Benefits related to an air bearing surface include damping which is very useful when the disc drive system is exposed to external shocks. Such shocks are particularly problematic for lap top or portable computers. Furthermore, the air bearing surface 54 can be designed such that the resultant air bearing shown generally at 80 in Figure 2 will start to provide lift and pads 58-64 begin to wear. If the air bearing includes a negative air bearing section, it may be desirable to saturate the negative air bearing section during initial operation such that when the pads are wearing, the positive portion of the air bearing surface provides additional lift to thereby provide a positive clearance of the air bearing surface. Other design strategies can be adopted including using a negative net suction after a wear-in period to thereby provide more effective damping.

The lift force of the present invention can be designed to follow a simple graph such as that shown in Figure 4. Figure 4 shows the relationship between the separation of slider 10 from disc surface 56, the lift force provided by the air bearing surface 54 due to the air bearing 80 and the contact force between the pads and the disc surface 56 due to the preload lift and any other effects. The sum of the lift force and the contact force equals the preload force on the slider. The interface can be designed so that as the pads 58-64 wear in, the lift force balances the existing contact force and thereby transitions to a "flying" interface.

-7-

An intermediate configuration is also possible in which the slider 10 is in elastic contact with disc surface 56 after an initial wear period.

5 The operation of slider 10 is illustrated in exaggerated form in Figure 5. As slider 10 tends to pitch up at the leading edge, the height h and position l from the trailing edge are selected such that h is equal to $\tan(\alpha) \cdot l + d$, where α is the pitch angle and d is a small value which provides the separation between the
10 head 50 and the disc surface 56. In the present invention, the height h is decreased as the pad wears until the point is reached at which time the slider is in equilibrium.

15 Figure 6 is a graph showing the distribution of heads relative to fly height from a typical manufacturing process. The present invention is effective when used with those heads which would be in contact with the disc surface. In the prior art, these heads would typically be discarded. With the invention,
20 these heads may be used and the contact pad will compensate for the difference between the lift force from the air bearing and the preload force from the armature. For example, if the preload force is 500 mg and the lift force is 400 mg, the contact force on the
25 pad will be 100 mg. Preferably, the pad will wear to a point where the pad is just slightly touching the disc surface.

30 The present invention is readily applicable to existing slider designs. The invention does not require accurate fly height control during manufacture. The air bearing can be designed to achieve a net lift in order to accommodate high preload applications such as those required for portable devices. The invention allows a transition from contact technology to flying technology

-8-

as the pads wear. The heights of the pads are not necessarily the same. For example, the front pads can be designed to be higher to thereby provide additional lift during takeoff so that the contact occurs along the rear pads only. Furthermore, the invention can be extended to include independent air bearing areas which surround each of the pads such that each micro air bearing provides both damping and lift functions.

A slider in accordance with the present invention may be manufactured using known slider formation technologies including additive or subtractive processes, machining, milling, etc. The pads may be formed as integral components or may be deposited separately from the main slider body. Variable pad hardness may be achieved by adding hydrogen to the DLC during fabrication. Further, note that in the present invention the actual contact area, when the slider is contacting the disc surface, is over the relatively small pad area as opposed to over the entire slider surface as in prior art designs. For example, 10,000 microns².

Although the present invention has been described with reference to preferred embodiments, workers skilled in the art will recognize that changes may be made in form and detail without departing from the spirit and scope of the invention.

WHAT IS CLAIMED IS:

1. A storage device, comprising:
a storage medium; and
means for carrying a transducer used to read
and write information onto the storage
medium.
2. A storage device comprising:
a disc storage medium having a disc surface;
an armature having a preload force;
a transducer head carried on the armature
proximate the disc storage medium;
transducing circuitry coupled to the
transducer;
a slider coupled to the armature and the
transducer adapted to position the
transducer proximate the disc, the
slider including an interface surface
facing the disc surface having an air
bearing region adapted to form an air
bearing with the disc and having a
contact pad extending from the air
bearing region and contacting the disc
surface with a contact force, wherein
the pad has a height which is sufficient
to contact the disc surface and thereby
prevent contact between the disc surface
and the transducer during normal
operation.
3. The storage device of claim 2 wherein the
height of the pad compensates for a difference between
a lift force due to the air bearing and the preload
force on the slider.
4. The storage device of claim 2 wherein the air
bearing provides an opposed lifting force substantially

-10-

equal to the preload force minus the contact force acting on the contacting pad.

5. The storage device of claim 2 including sacrificial wear layers on the contact pad.

6. The storage device of claim 5 wherein the sacrificial wear layers comprise a diamond-like coating (DLC).

7. The storage device of claim 2 wherein the contact pad has a height which wears in and reaches equilibrium.

8. The storage device of claim 2 wherein the slider includes multiple contacting pads positioned on slider.

9. The storage device of claim 8 wherein the contact pads have different heights.

10. The storage device of claim 8 wherein contact pads near a leading edge of slider have a greater height than contact pads near a trailing edge of the slider.

11. The storage device of claim 2 wherein the contact pad wears during normal operation of the storage device until an equilibrium is reached between the lifting force due to the air bearing and a contact force between a pad and the disc surface.

12. The storage device of claim 2 including a plurality of contact pads and individual air bearing regions proximate each of the contact pads.

13. The storage device of claim 2 wherein the air bearing provides a damping force to damp shock or vibration on the slider during operation.

14. The storage device of claim 2 wherein the pad provides sufficient fly height to protect the transducer from contact with an asperity.

15. The storage device of claim 2 wherein the transducer comprises a magnetoresistive head.

-11-

16. The storage device of claim 2 wherein the transducer comprises a magneto-optical head.

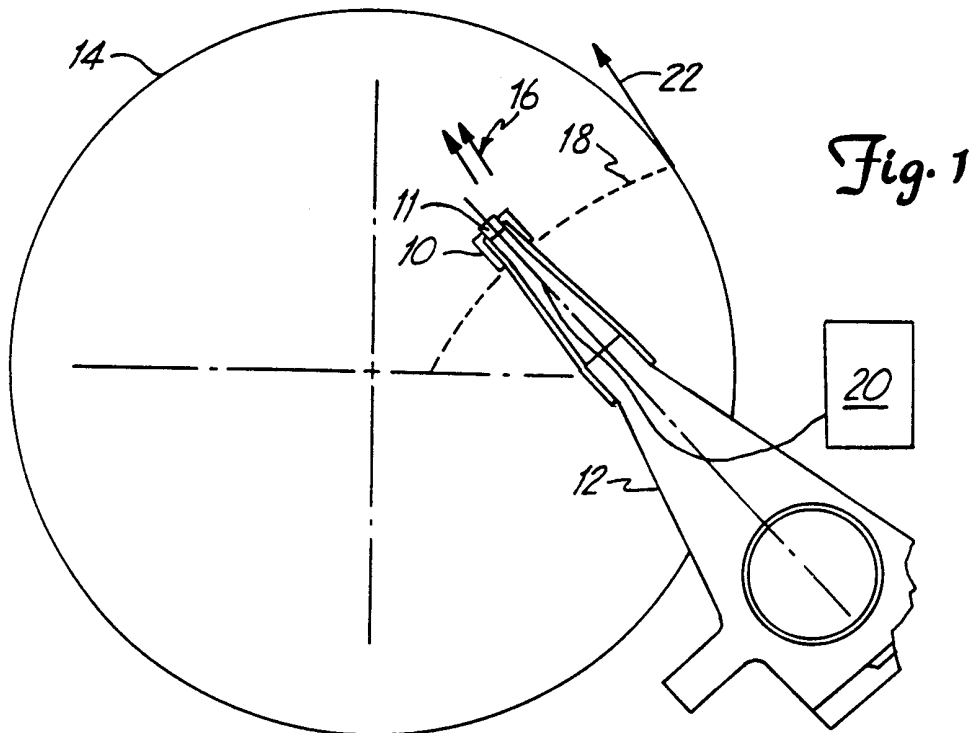

Fig. 1

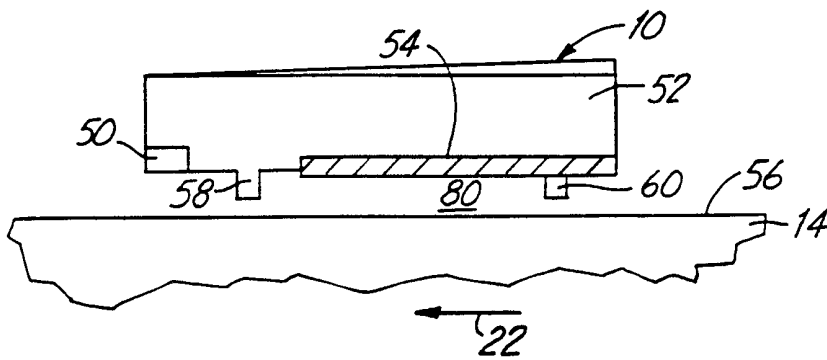

Fig. 2

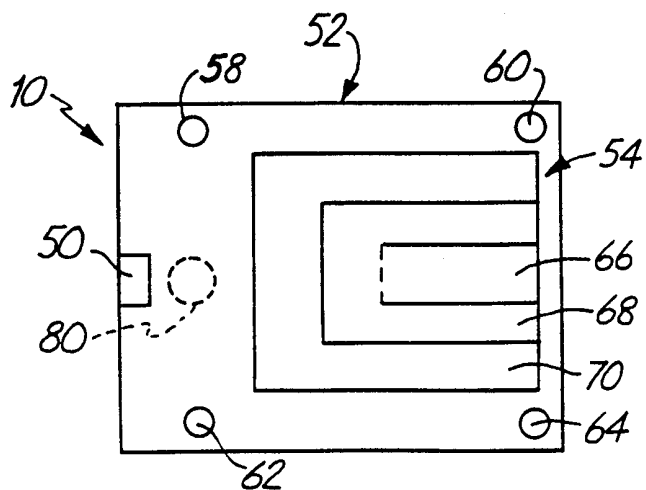
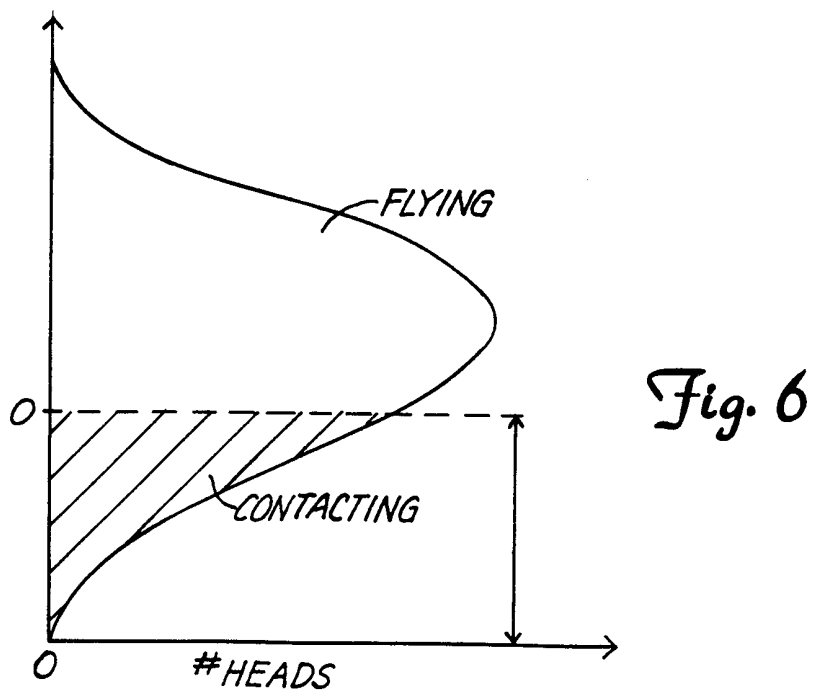
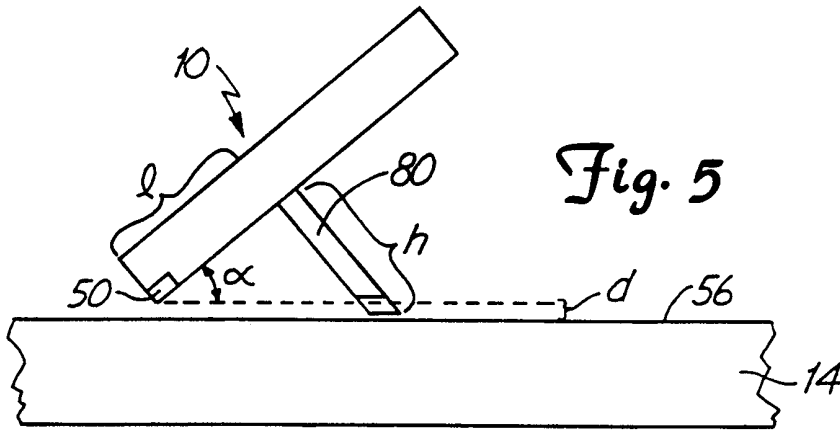
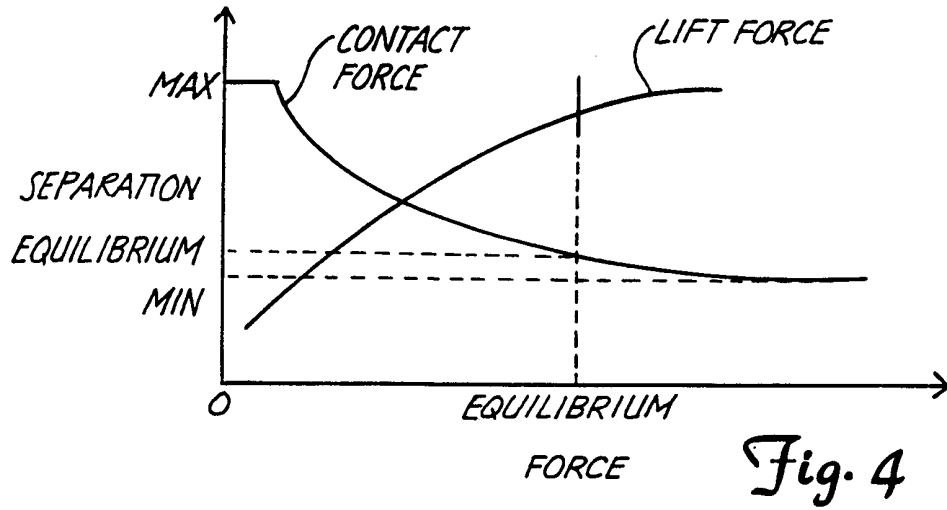

Fig. 3



INTERNATIONAL SEARCH REPORT

International application No.
PCT/US98/05628

A. CLASSIFICATION OF SUBJECT MATTER IPC(6) :G11B 5/60, 17/32, 21/21 US CL :360/103 According to International Patent Classification (IPC) or to both national classification and IPC		
B. FIELDS SEARCHED Minimum documentation searched (classification system followed by classification symbols) U.S. : 360/103, 102, 104 Documentation searched other than minimum documentation to the extent that such documents are included in the fields searched NONE Electronic data base consulted during the international search (name of data base and, where practicable, search terms used) APS; GPI WEBCLIENT 2.0 search terms: slider, air bearing, contact, wear, pads, skis, rails, struts, pitching, DLC, diamond-like-carbon		
C. DOCUMENTS CONSIDERED TO BE RELEVANT		
Category*	Citation of document, with indication, where appropriate, of the relevant passages	Relevant to claim No.
X	JP 8-279132 A (KODAIRA ET AL) 22 October 1996, abstract, figs. 1-3, 10, 13.	1-16
A	US 5,285,337 A (BEST ET AL) 08 February 1994, entire document.	1-16
A	US 5,420,735 A (HAINES) 30 May 1995, see entire document.	1-16
A	US 5,499,149 A (DOVEK) 12 March 1996, see entire document.	1-16
<input type="checkbox"/> Further documents are listed in the continuation of Box C. <input type="checkbox"/> See patent family annex.		
* Special categories of cited documents:	"T"	later document published after the international filing date or priority date and not in conflict with the application but cited to understand the principle or theory underlying the invention
"A" document defining the general state of the art which is not considered to be of particular relevance	"X"	document of particular relevance; the claimed invention cannot be considered novel or cannot be considered to involve an inventive step when the document is taken alone
"B" earlier document published on or after the international filing date	"Y"	document of particular relevance; the claimed invention cannot be considered to involve an inventive step when the document is combined with one or more other such documents, such combination being obvious to a person skilled in the art
"L" document which may throw doubts on priority claim(s) or which is cited to establish the publication date of another citation or other special reason (as specified)	"a"	document member of the same patent family
"O" document referring to an oral disclosure, use, exhibition or other means		
"P" document published prior to the international filing date but later than the priority date claimed		
Date of the actual completion of the international search 18 JUNE 1998	Date of mailing of the international search report 13 AUG 1998	
Name and mailing address of the ISA/US Commissioner of Patents and Trademarks Box PCT Washington, D.C. 20231 Facsimile No. (703) 305-3230	Authorized officer WILLIAM J. KLIMOWICZ Telephone No. (703) 305-3452	