

Feb. 17, 1953

N. MEURER

2,628,828

PORTABLE AERATION APPARATUS

Filed Aug. 27, 1948

3 Sheets-Sheet 1

Fig. 1

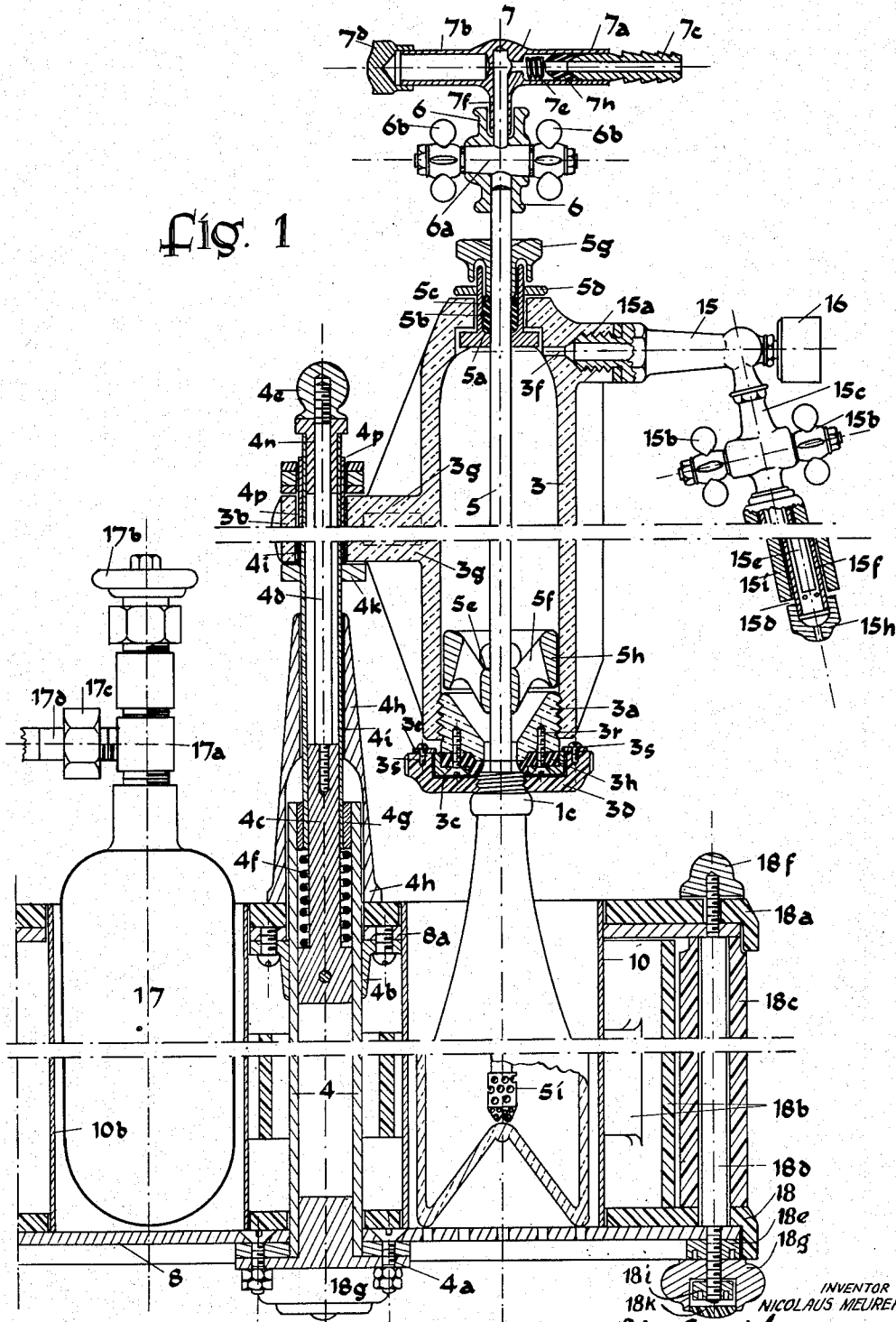

INVENTOR
NICOLAUS MEURER
BY *Naylor & Jassaguz*
ATTORNEYS

Feb. 17, 1953

N. MEURER
PORTABLE AERATION APPARATUS

2,628,828

Filed Aug. 27, 1948

3 Sheets-Sheet 2

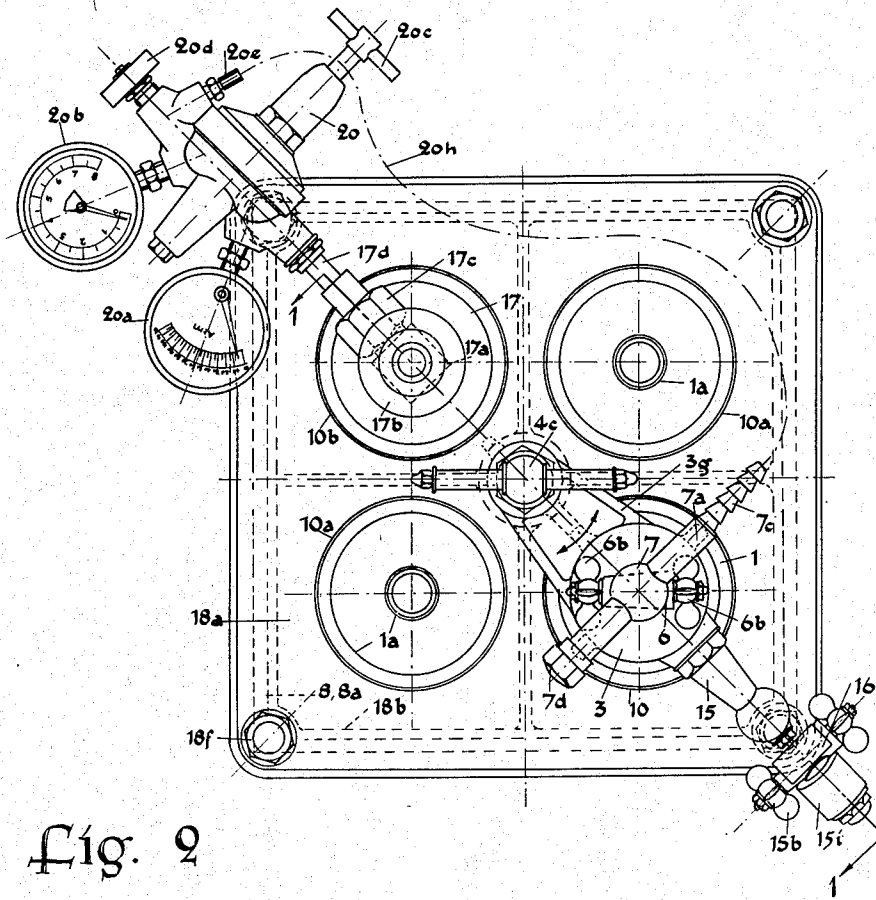

Fig. 2

INVENTOR
Nicolaus Meurer

Feb. 17, 1953

N. MEURER

2,628,828

PORTABLE AERATION APPARATUS

Filed Aug. 27, 1948

3 Sheets-Sheet 3

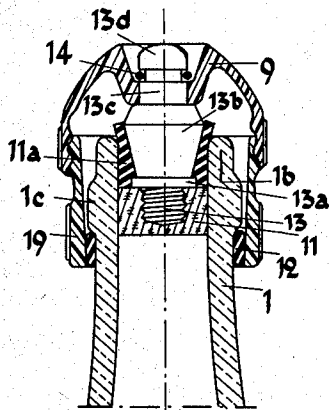
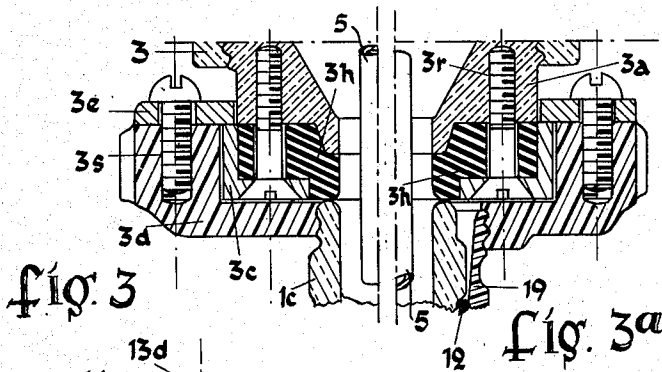

Fig. 4

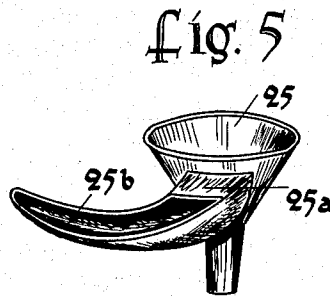

Fig. 5

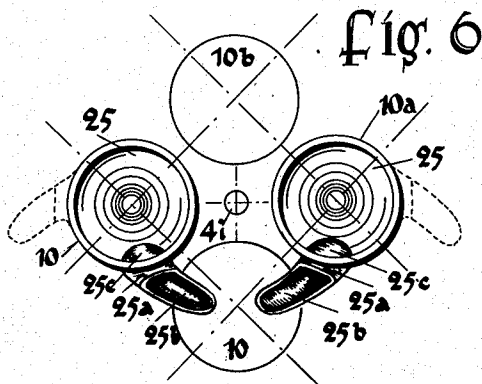

Fig. 6

INVENTOR
NICOLAUS MEURER
BY *Naylor and Kellogg*
ATTORNEYS.

UNITED STATES PATENT OFFICE

2,628,828

PORTABLE AERATION APPARATUS

Nicolaus Meurer, Radolfzell/Baden, Germany

Application August 27, 1948, Serial No. 46,541

8 Claims. (Cl. 261—121)

1

Portable devices are known to charge beverages which have been filled into bottles or the like receptacles with carbonic acid. To this end each bottle is lowered into a protective shell or sleeve having a bottom, whereas the upper rim of the mouth of the bottle neck is forced against a resilient annular insert provided at the bottom of a closed-top, atomizing and mixing chamber coaxial with the bottle. The apertured top of the mixing chamber is provided with a stuffing box, through which suitably extends a carbonic acid feed pipe, the upper end of which is connected by means of a hose or pipe to a container of pressurized carbonic acid gas. The lower end of this pipe is provided with a gas feed nozzle or sprayer, the small apertures of which permit of the escape of the carbonic acid gas fed thereto into the bottom zone of the liquid contents of the bottle, when a valve of the carbonic acid container is opened. Thereby upon each opening of the valve a portion of the liquid contents of the bottle is forced into the interior of the mixing chamber and atomized. During these operations particles of air mechanically or chemically combined with the liquid contents are liberated and, being mixed with carbonic acid gas, accumulate inside the mixing chamber near its top. There is provided a venting or bleeder valve closed when the carbonic acid is admitted but opened for a short time after pressure equalization between mixing chamber and bottle, and then closed again. Thus the mixture is allowed to escape. This procedure is repeated several times. Upon each atomizing operation carbonic acid from the liquid contents replaces vigorously the air escaped and combines with the atomized liquid particles entered into the mixing chamber. When all air has escaped from the beverage and has been removed by venting from the mixing chamber, and when the beverage has flown back completely into the bottle and the carbonic acid has escaped from the mixing chamber so that the pressure gauge thereof indicates zero, then the gastight connection between the mixing chamber and the bottle is interrupted and after the carbonic acid feed pipe has been moved upwardly and while the valve for the carbonic acid is closed, the bottle is preliminarily closed, then pulled out of the protective sleeve or shell and replaced by another bottle to be treated. Only after the removal of the bottle the treatment of which has just been completed is the preliminary closure replaced by a final one.

Using all essential parts and charging operations of these known types of apparatus, it has

2

been found that the output thereof may be increased when the mixing chamber, which has previously been supported in a stationary relationship to the protective sleeve, is now mounted for swinging movement about a support member, which extends vertically upwardly from a base adapted to carry a plurality of open-topped, filled bottles each lowered into a protective sleeve. Where these individual bottles are placed on the base along the arc of a circle the radius of which equals the radial distance between the axis of the mixing chamber and the center of the pivotal movement of the mixing chamber about its support, any of the bottles placed on the base may selectively be subjected to the charging treatment, whereas at the same time the bottle liquid contents of which has been treated just before may be closed definitely, then lifted out of its protective shell, and replaced by a bottle the liquid contents of which is to be treated thereafter.

A first object of this invention, which utilizes such a swingable mixing chamber, is to prevent during the swing of the mixing chamber from one operative position to the next the carbonic acid feed pipe, being supported only at the top of the mixing chamber, from swaying to and fro and from laterally moving relative to its support, as well as from moving eccentrically to the center line of the bottle through the annular opening between the lower part of the mixing chamber and the mouth of the bottle into the bottom zone thereof, whereby the charging operation would be disturbed considerably.

It is another object to provide at the vertical support member for the mixing chamber swingable about said member, means to lift the mixing chamber somewhat relative to the support and to transmit the weight of the mixing chamber to the base member of the carrier.

Further objects of the invention will be apparent from the following description and the accompanying drawings, in which an embodiment of the invention is shown diagrammatically and by way of example.

Figure 1 is a fragmentary sectional view taken along lines I—I of Figure 2;

Figure 2 is a plan view, on a somewhat enlarged scale, of the novel apparatus;

Figure 3 is an enlarged partial diametral section view showing one form of connection between the mixing chamber and the neck of a bottle;

Figure 3a is an enlarged partial diametral section view showing another form of connection

3

between the mixing chamber and the neck of a bottle;

Figure 4 is a vertical section through a bottle closure;

Figure 5 is a perspective view of a funnel which may be used in connection with the aerator; and

Figure 6 is a diagrammatic plan view showing the relative position of the parts of the aerator.

Referring now to the drawings in greater detail, it will be seen that there are arranged, on a base plate 3, preferably consisting of light metal, in a circle around a central metallic pipe column 4 secured on base plate 3 at 4a, a plurality of, e. g. in this case four, sheet metal shells 10, 10a and 10b, which are open at their top and bottom ends. A second metal plate 3a of similar form and dimensions but having apertures for the passage of the end portions of the shells 10, 10a and 10b, is connected to plate 3, at a proper distance and parallel thereto, so as to form a frame together therewith. The top surfaces of the plates 3, 3a are covered by further plates 13, or 13a, which are also formed with apertures for the passage of the shells and consist of synthetic resin or ceramic materials. The space between the metal plates 3, 3a and the covering plates 13, 13a is enclosed by a wall frame 13b of synthetic or ceramic material.

Said parts are interconnected to form a rigid and yet easily portable supporting frame by four connecting stuts, e. g., pipe columns 13c of synthetic resin or ceramic material, said columns being arranged at the corners of said plate. A metal bolt 13d, whose tapered ends are threaded for nuts 13f or 13e, respectively, extends through each of said pipe columns. The lower portion of each bolt 13d may also extend through a foot member 13g, of synthetic or ceramic material, which member is held in position by a nut 13i and has a rubber insert 13k. Said parts are held in their relative positions by the frame 13b being inwardly bulged or recessed at the joints with the tubular pillars 13c, which fit snugly in said recesses.

The shells 10 and 10a serve to receive each a bottle 1 or 1a containing a liquid; the shell 10b serves to hold a carbonic acid container 17. A shut-off spindle 17a, fitted with a hand wheel 17b, has connected to it by means of a pipe branch or socket 17d and a cap nut 17c the reducing valve 20 with gauges 20a and 20b to indicate the contents of carbonic acid in said container and the outlet pressure, respectively, said reducing valve having a handle-operable spindle 20c to control the outlet pressure. The opening and shutting-off of the carbon dioxide flowing from the pipe socket 20e into a supply hose 20h connected thereto is effected by the actuation of a hand wheel 20d. The metal tube pillar 4, secured to base plate 3 at 4a and supported by plate 3a at 4b, has therein an insert bolt 4c fixedly secured thereto by a pin extending transversely of the lower or larger diametral portion of the bolt. The upper or reduced diametral portion of the bolt is surrounded by a helical spring 4f, which engages the underside of a ring 4g slidably disposed in the tube pillar 4 and secured to the lower end of a tube 4i, said tube 4i being in a sleeved relation to a bolt 4d, which has its lower end screwed into the upper end of bolt 4c and its upper end projecting through a drilled metal stopper 4n serving as the closure for the upper end of tube 4i. The upper end of bolt 4d has a handle 4e in threaded engagement therewith, which handle is capable of bearing the whole

4

weight of the apparatus when it is to be transported. The cylinder ring 4g is movable piston-like in the upper part of the pipe column. The insert part 4i continues through an aperture in the support arm 3g of the mixing chamber, which aperture is closed by the stopper 4n. An ornamental tubular pillar 4h adapted to be supported on plate 13a, surrounds a lower portion of tube 4i, while the upper portion thereof passes through a metal sleeve 4p inserted in the hub body 3b of the mixing chamber 3. Said hub body is in an eccentric position with respect to chamber 3, its lower end finding a bearing support on a flange offset 4k of insert pipe 4i. The upper end of sleeve 4p is provided with a pair of nuts terminating it. The spring 4f relieves the weight of chamber 3, which advantageously is made of porcelain or glass and stiffened by ribs against the carbon dioxide pressure to be set up inside the chamber. The spring 4f transmits the load of this weight by way of 4k, 4i, 4g, and 4c, to the tubular pillar 4 and thus to the base plate 3 and the frame parts 3a and 13d to such an extent that its spring force slightly outweighs the load due to the weight. Therefore, when the mixing chamber 3 is not used and during the pauses of operation the bottom member 3a fitted into the mixing chamber will float a small distance above the mouth of the bottle put into protective shell coaxially with the center line of chamber 3.

The mixing chamber 3 is connected to its hub body 3b by at least two ear lug members 3g. Where the latter, as in this instance, are of U-shaped section, it seems advisable to connect them by a vertical central rib. The chamber 3 with its bearing bush 4k, 4p can be swung around tube 4i as a pivot, in the direction of the arrow indicated in Figure 2. The inner space of the chamber has longitudinally extending there-through in a manner known a gas feed tube 5 terminated at its lower end by a sprinkler foot 5i and being gastightly guided at the head portion of the mixing chamber by means of a stuffing box 5a, 5b, 5c, 5d and 5g, and terminated by a stopcock 6, 6a, 6b, to which the carbonic acid is fed through a pipe branch 7, 7a, 7b and 7d, designed as a draw handle, and through a quick-coupling nipple 7c, which in turn is connected to the supply hose 20h secured to the pipe branch 20e of reducing valve 20, a spring 7e pressing against the resilient member 7h inserted into the sleeve to establish a gastight connection between the nipple 7c and the duct 7f.

The air discharge channel 3f of the mixing chamber has connected to it the screw nipple 15a of a tube 15 carrying the pressure gauge 16. Connected to the tube 15 is a faucet 15c. The spigot of said faucet is provided with handles 15b at either end. By turning the spigot the cross bore thereof is moved into or out of communication with the tube 15e. Said tube 15e is surrounded by a tube 15f upon which is mounted a bored handle 15i. An axially bored cap screw 15h, mounted upon the end of tube 15f, forms an annular slot 15d with the adjacent end of the bored handle 15i. Adjacent this annular slot, the tube 15f is provided with perforations. Therefore with the bore of the faucet communicating with tube 15e, said faucet discharges the air, which is released from the beverage into the mixing chamber head as quantities of the beverage are thrown upwards, to be mixed with carbonic acid gas through the tube 15e partially through the perforations of cover tube 15f and partially through the axial aperture of

the cap, tube 15*h*. It is a necessary premise, however, that the carbonic acid tube 5 be lifted above the level of the liquid in the bottle.

The bottom 3*a* of the mixing chamber, made of porcelain or glass and rendered gastight by a suitable cement, is advantageously screwed in and carries a sleeve body 3*c* secured thereto by screw bolts 3*r* and containing a packing ring 3*b* of resilient rubber, Figure 3, and an annular member 3*d*, preferably made of synthetic resin. This annular member is mounted to revolve around the outer periphery of sleeve 3*c* and is prevented from falling down therefrom by a metal ring 3*e* covering its upper rim, said metal ring being screwed to 3*d* at 3*s* and supported on 3*c*. The outer periphery of ring member 3*d* is roughened or ribbed so that it can easily be seized by hand and turned towards chamber 3. The central bottom aperture of the ring member has provided therein coupling means in the form of female threads adapted to be engaged with suitable counter-coupling members provided at the outside surface of the neck of the bottle, whereby the soiling of parts of the apparatus by dripping liquid can be avoided almost completely.

Where the coupling means have been provided during the manufacture of the bottles in the outer surface of their necks, e. g., in the end portion of a bottle, which portion is provided above the known neck reinforcement 1*c*, as in Figure 3, the gastight coupling between chamber 3 and bottle may be established by an engagement of the female threads of the ring member 3*d* with the male threads of said end portion of the bottle neck. In this engagement the chamber 3 is somewhat pulled down by a turning of ring member 3*d* overcoming the opposing force of spring 4*f*.

However, where the neck portion of the bottle has no coupling members formed thereon, as shown in Figure 3*a*, a gastight connection between chamber 3 and bottle 1 may be established as follows, with reference to Figure 4 showing a vertical section of a bottle closure: A cork stopper 11 is formed with a blind hole into which is screwed a spindle 13*a*, 13*b*, 13*e*, 13*d*. In addition to the cork 11 the spindle on its middle part 13*b* carries a sleeve 11*a* of soft rubber, and above the neck portion 13*c* which passes through the hub of a cap 9 of synthetic resin, it carries a spring or retaining ring 14 of spring wire seated in an annular groove underneath the spindle head 13*d* and holding the parts 11, 13*a*, 13 and 9 together as a unit of construction. The cap 9 is formed with a female thread fitting into the male thread of an auxiliary sleeve 19, of synthetic resin, with a conical bore widening from bottom to top. The smallest inside diameter of the conical bore slightly exceeds the outer diameter of the neck reinforcement 1*c* lying underneath the end portion 1*b*. Now, before sleeve 19 is put over the bottleneck, a resilient rubber ring 12 is rolled down over the neck portions 1*b*, 1*c* and is extended thereby in such a way that it finds a stop at the lower rim of reinforcement 1*c*, sleeve 19 following over said neck portions whereby the lower conical zone is caused to compress the ring and oppose any upward displacement of sleeve 19. This displacement of sleeve 19 in a bottle closure as shown in Figure 4 may be accomplished by a turning of cap 9 with engagement of the female thread with the male thread of sleeve 19 and pressing the rubber body 11*a* gastightly against the mouth of the bottle.

According to another modification, cap 9 with its associated components may be omitted, while

the same sleeve 19 with its ring 12 is utilized for a gastight connection of chamber 3 and bottle 1, as will be seen clearly from Figure 3*a*.

In order to avoid swinging and bending of the gas feed tube 5, 5*i* upon pivotal swinging of mixing chamber 3 about tube 4*i*, the mixing chamber has provided in its interior, immediately above the bottom member 3*a*, a second bearing and centering member for the gas feed tube. According to the invention this bearing member consists of a vertically slidable body of pure aluminum, ceramic or synthetic material, whose hub 5*e* surrounds tube 5 as a loose fit. From the hub 5*e* to the inner periphery of the cover of the chamber a portion 5*h* extends, which is connected with ribs 5*f* to the hub 5*e* so that between any two successive ribs there is ample clearance for the passage of quantities of liquid which have been forced upwardly and are flowing down. The slidability of the bearing member 5*e*, *f*, *h*, also permits of the bearing body to be moved upwardly with the liquid and of its automatic return to its initial position after an equalization of the pressure between the chamber and bottle. Thus, on the one hand the tendency of the carbonic acid to atomize the beverage is not hindered, while on the other hand the viscous foam developing inside the chamber is turned by the returning bearing member, whereby its recondensation into a liquid, which is capable of flowing off, is facilitated.

When the feeding of gas into the liquid flown back into the bottle is completed, the chamber is disconnected from the bottle 1 and the gas feed pipe is pulled upwardly above the mouth of the bottle. Owing to the excess power of spring 4*f* the chamber 3 is thus lifted automatically by a small distance on tube 4*i*. Now the chamber 3 may be moved automatically in the direction of the arrow in Figure 2 in the left or right hand position, or the bottle, still remaining in its protective shell 10, may be sealed first, e. g., by means of a cap 9 to be screwed on the auxiliary socket 19 after the mixing chamber has been lifted somewhat further by hand. In both cases the bottle is then lifted from shell 10.

Figure 5 shows diagrammatically a funnel 25, 25*a*, 25*b* designed according to the invention to avoid the soiling parts of the apparatus when the mixing chamber is swung into another position.

Figure 6 shows diagrammatically in a plan view the positions of the three protective sleeves 10 and 10*a*, with two of said funnels immersed into the mouths of the lateral bottles 1*a*; in this case it is assumed that the closed bottle has been removed already from the front protective sleeve 10 and that the funnels, whose beaks 25*b* during the gas feeding operation in the front protective sleeve 10 have been in the position shown in dotted lines, have been swung into the position shown in solid lines only because for the time being no further gas feeding operation is intended.

It will be understood that the operator is free to effect the aeration of the beverage in the bottle either always only in the front position of the bottle 1, or alternately in the left and right hand positions. For the optimum utilization of the time required for feeding the gas, he may utilize the intervals during which the beverage forced upwardly in the chamber is flowing back into the bottle, for picking up and immersing into the protective sleeves those bottles from the vicinity of the apparatus, which according to their contents are to be aerated in a predetermined

7

order. Assuming that the aeration is to be effected regularly in the front position, there will be filled bottles in the lateral sleeves 10a and the funnels 25 will engage the mouth of one or both of them. Then, after the removal of the treated front bottle, the left or right hand bottle is lowered into the front sleeve 10 connected to chamber 3 and is replaced by another filled bottle, into which the funnel is introduced in the position shown with dotted lines.

Before completing the aerating operations, at the latest, the tube 5 is raised by such a distance, with the cock 6, 6a still in its open position, that the sprinkler head 5i comes to lie in the conical crater of the bottom member 3a of the mixing chamber. Thus, for a sufficiently long period of time any rising of carbonic acid bubbles, and the development of foam above the level of the beverage, are prevented so that after the next following discharge of air from inside the mixing chamber, by the opening of cock 15b, c at atmospheric pressure, the disconnection of parts 1, 3 may be effected. It is followed, before the outward swing of the mixing chamber about 4i, by the swinging of the funnels 25, 25a, b, placed in one or both of the lateral bottles 1a, so that their beaks 25b come into the position shown in full lines in Figure 6. Only now is the mixing chamber swung to the left or right, whereby the collected drops get into the respective vessel and soiling of parts of the apparatus is prevented.

I claim:

1. Aeration apparatus comprising a metallic base plate, a vertical pillar mounted thereon, a second metal plate mounted in parallel spaced relationship to the base plate for supporting said pillar, connecting struts between said base plate and said second plate to form said base plates into a supporting frame, a protective sleeve member vertically disposed within said supporting frame in laterally spaced relation to said pillar, a bottle located within said protective sleeve, a mixing chamber member having an arm in sleeved relation to said pillar and means associated with said pillar constituting a bearing support for said arm and operable to allow horizontal swinging movement of said chamber member, means associated with the lower end of said chamber member for establishing a gas-tight connection between said bottle and the mixing chamber, means including a vertically movable gas feed tube passing through the chamber and operable to introduce pressurized gas into the bottom zone of the liquid contents of said bottle in such manner that a portion of the liquid in said bottle is forced into said chamber and atomized therein, means for venting said chamber for said aerating and atomizing operation, means allowing the liquid to flow into the bottle from said chamber after the pressure is equalized in the bottle and chamber, a container for carbonic acid having a reducing valve and socket connection with the gas feed tube, means associated with said mixing chamber enabling the raising of said gas feed tube out of the bottle during aeration, and a handle at the upper end of said pillar adopting the apparatus to be transported as an integral unit.

2. Aeration apparatus according to claim 1 having a tubular pillar, a double diametral insert bolt having its lower and larger diametral end fixedly secured within said pillar, a helical spring surrounding the upper end or reduced diametral portion of said bolt, a tube in jacketing relation to the upper end of said bolt supported on said

8

spring and forming a pivot for the hub of the arm of said chamber member, and an elongated bolt connected to said insert bolt and terminating in a handle above said hub.

3. Aeration apparatus according to claim 1 having four ninety degree spaced vertically disposed compartments provided with protective liner sleeves, with said bottle being located in one compartment, the carbonic acid container being located in the compartment diagonally opposed thereto, and replacement bottles located in the other two compartments, said pillar being located centrally between said compartments.

4. Aeration apparatus comprising a bottle, a mixing chamber member disposed above said bottle in alignment therewith, means associated with the lower end of said chamber including a packing ring and ring member mounted to revolve freely about the outer circumference of said lower end and carried by said lower end, said ring member including a bottom plate provided with a central aperture, an auxiliary sleeve having a conically extending bore and coupling means at its upper end adapted to cooperate with coupling means provided in the aperture of said ring member, said auxiliary sleeve being disposed about the mouth of said bottle, a resilient ring adapted to engage behind the lower face of the re-enforcing flange of the bottle-neck of said bottle and adapted to thereby prevent said auxiliary sleeve from being removed from said bottle-neck during the coupling operation, whereby a gas-tight connection between said bottle and the chamber of said chamber member may be established, means including a vertically movable gas feed tube passing through said chamber and operable to feed gas into the bottom zone of the liquid contents of said bottle in such manner that portions of the liquid within the bottle are forced into the chamber and atomized therein, means for venting said chamber during said aerating and atomizing operation, means allowing the liquid forced into said chamber to flow back into said vessel from said chamber after equalization of pressure between the bottle and chamber, mechanically operable mounting means for moving said chamber away from said vessel in a horizontal swinging movement, and means for raising said gas feed tube out of said vessel during aeration, said auxiliary sleeve being also operable to permit the gas-tight sealing of the bottle after its disconnection from the mixing chamber member, said sealing being adapted to be achieved with a bottle head cap.

5. A portable aeration apparatus for the successive charging with carbonic acid of the liquid contents of each of several bottles comprising a base having a plurality of open topped protective shells therein for the reception of the bottles, a vertical support member carried by said base and extending upwardly therefrom, a mixing chamber member mounted for horizontal swinging movement about said support member and having its outlet end alignable with the mouths of said bottles, means carried at the lower end of said chamber member to form a gas-tight connection between said member and the mouth of a bottle, a vertically disposed and vertically movable gas feed tube carried by said chamber member and extending longitudinally through said chamber member, said tube having means at its upper end to form a connection with a container of carbonic acid and having at its lower end a gas feed nozzle insertable through the mouth of a bottle whereby the

bottom zone of liquid contents of the bottle may be charged with carbonic acid, the chamber of said member being in communication with the interior of the bottle during the charging operation, whereby a portion of said liquid contents may be driven upwardly into said chamber and flow downwardly therefrom upon equalization of the pressure within said chamber and bottle, a bleeder valve carried by said chamber member adapted to be opened following equalization of the pressure within said chamber and bottle to bring said chamber into communication with the atmosphere, and movable means within said chamber in sleeved relation with the gas feed tube operable to prevent lateral movement of said tube and so arranged as to allow for passage of the liquid to and from said chamber.

6. A portable aeration apparatus for the successive charging with carbonic acid of the liquid contents of each of several bottles comprising a base having a plurality of open topped protective shells therein for the reception of the bottles, a vertical support member carried by said base and extending upwardly therefrom, a mixing chamber member mounted for horizontal swinging movement about said support member and having its outlet end alignable with the mouths of said bottles, means carried at the lower end of said chamber member to form a gas-tight connection between said member and the mouth of a bottle, a vertically disposed and vertically movable gas feed tube carried by said chamber member and extending longitudinally through said chamber member, said tube having means at its upper end to form a connection with a container of carbonic acid and having at its lower end a gas feed nozzle insertable through the mouth of a bottle whereby the bottom zone of liquid contents of the bottle may be charged with carbonic acid, the chamber of said member being in communication with the interior of the bottle during the charging operation, whereby a portion of said liquid contents may be driven upwardly into said chamber and flow downwardly therefrom upon equalization of the pressure within said chamber and bottle, a bleeder valve carried by said chamber member adapted to be opened following equalization of the pressure within said chamber and bottle to bring said chamber into communication with the atmosphere, movable means within said chamber in sleeved relation with the gas feed tube operable to prevent lateral movement of said tube and so arranged as to allow for passage of the liquid to and from said chamber, a cross channel located in the upper part of the mixing chamber member transversely of the mixing chamber, and a manually operable faucet for opening and closing said channel, said channel opening to a pipe leading downwardly outside the mixing chamber member, whereby when the faucet is opened the inside of the mixing chamber member may be depressurized, the depressurizing pipe connected to the cross channel of the mixing chamber member forming the carrier for a handle whereby the mixing chamber member is pivotally movable about its support member into and out of a position coaxial with any of said bottles.

7. A portable aeration apparatus for the successive charging with carbonic acid of the liquid contents of each of several bottles comprising a base having a plurality of open topped protective shells therein for the reception of the bottles, a vertical support member carried by said base and extending upwardly therefrom, a mixing cham-

ber member mounted for horizontal swinging movement about said support member and having its outlet end alignable with the mouths of said bottles, means carried at the lower end of said chamber member to form a gas-tight connection between said member and the mouth of a bottle, a vertically disposed and vertically movable gas feed tube carried by said chamber member and extending longitudinally through said chamber member, said tube having means at its upper end to form a connection with a container of carbonic acid and having at its lower end a gas feed nozzle insertable through the mouth of a bottle whereby the bottom zone of liquid contents of the bottle may be charged with carbonic acid, the chamber of said member being in communication with the interior of the bottle during the charging operation, whereby a portion of said liquid contents may be driven upwardly into said chamber and flow downwardly therefrom upon equalization of the pressure within said chamber and bottle, a bleeder valve carried by said chamber member adapted to be opened following equalization of the pressure within said chamber and bottle to bring said chamber into communication with the atmosphere, movable means within said chamber in sleeved relation with the gas feed tube operable to prevent lateral movement of said tube and so arranged as to allow for passage of the liquid to and from said chamber, a cross channel located in the upper part of the mixing chamber member transversely of the mixing chamber, and a manually operable faucet for opening and closing said channel, said channel opening to a pipe leading downwardly outside the mixing chamber member, whereby when the faucet is opened the inside of the mixing chamber member may be depressurized, the depressurizing pipe connected to the cross channel of the mixing chamber member forming the carrier for a handle whereby the mixing chamber member is pivotally movable about its support member into and out of a position coaxial with any of said bottles, the support member carried by the base being provided with means to equalize approximately the weight of the mixing chamber member and transmit said weight to the base, which means is operable to slightly lift the mixing chamber member automatically on the support member when the mixing chamber member, after the gas-tight connection with a bottle has been broken, is to be swung around said support member.

8. A portable aeration apparatus for the successive charging with carbonic acid of the liquid contents of each of several bottles comprising a base having a plurality of open topped protective shells therein for the reception of the bottles, a vertical support member carried by said base and extending upwardly therefrom, a mixing chamber member mounted for horizontal swinging movement about said support member and having its outlet end alignable with the mouths of said bottles, means carried at the lower end of said chamber member to form a gas-tight connection between said member and the mouth of a bottle, a vertically disposed and vertically movable gas feed tube carried by said chamber member and extending longitudinally through said chamber member, said tube having means at its upper end to form a connection with a container of carbonic acid and having at its lower end a gas feed nozzle insertable through the mouth of a bottle whereby the bottom zone of the liquid contents of the bottle may

11

be charged with carbonic acid, the chamber of said member being in communication with the interior of the bottle during the charging operation, whereby a portion of said liquid contents may be driven upwardly into said chamber and flow downwardly therefrom upon equalization of the pressure within said chamber and bottle, a bleeder valve carried by said chamber member adapted to be opened following equalization of the pressure within said chamber and bottle to bring said chamber into communication with the atmosphere, movable means within said chamber in sleeved relation with the gas feed tube operable to prevent lateral movement of said tube and so arranged as to allow for passage of the liquid to and from said chamber, a cross channel located in the upper part of the mixing chamber member transversely of the mixing chamber, and a manually operable faucet for opening and closing said channel, said channel opening to a pipe leading downwardly outside the mixing chamber member, whereby when the faucet is opened the inside of the mixing chamber member may be depressurized, the depressurizing pipe connected to the cross channel of the mixing chamber member forming the carrier for a handle whereby the mixing chamber member is pivotally movable about its support member into and out of a position coaxial with any of said bottles, the support member carried by the base being provided with means to equalize approximately the weight of the mixing chamber member and transmit said weight to the base, which means is operable to slightly lift the mixing chamber member automatically on the support member when the mixing chamber member, after the gas-tight connection with a bottle has been broken, is to be swung around said support member, said support member comprising a vertical pipe column provided above its lower end with a bearing sleeve, said pipe column being provided with a double diametral insert bolt, the lower, larger diametral end of which is se-

12

cured to the pipe column and forms the carrier for a helical spring surrounding the upper reduced diametral portion of said insert bolt, as well as for an insert pipe which is placed above the spring and which may be moved up and down in sleeved relation to said insert bolt, the lower end of said insert pipe having a cylinder ring firmly secured thereto movable piston-like in the upper section of the pipe column, said spring being in engagement with said ring and tending to move the same slightly upwards with its pipe, with said insert pipe, which surrounds the reduced diametral upper end of the insert bolt, continuing through a drilled opening in a support arm for the mixing chamber member, the lower end of which support arm rests on a flange offset of the insert pipe forming a support for the mixing chamber member, said drilled opening being closed at its upper end by means of a drilled stopper, through a drilled opening of which stopper passes the insert bolt, and a handle screwed into the upper end of the insert bolt adapted to carry the full load of the apparatus when the apparatus is to be moved by hand.

NICOLAUS MEURER.

REFERENCES CITED

The following references are of record in the file of this patent:

UNITED STATES PATENTS

Number	Name	Date
938,482	Haller	Nov. 2, 1909
1,115,834	Keifer	Nov. 3, 1914

FOREIGN PATENTS

Number	Country	Date
18,726	Great Britain	Aug. 18, 1913
233,743	Great Britain	May 18, 1925
656,518	Germany	Apr. 14, 1933
657,402	Germany	Sept. 28, 1935