



US 20070148618A1

(19) **United States**

(12) **Patent Application Publication**
Feine

(10) **Pub. No.: US 2007/0148618 A1**

(43) **Pub. Date: Jun. 28, 2007**

(54) **LIGHTED ULTRASONIC HANDPIECE AND COLOR CODE GRIP SYSTEM**

Publication Classification

(76) Inventor: **James Feine**, Houston, TX (US)

(51) **Int. Cl.**
A61C 3/03 (2006.01)

(52) **U.S. Cl.** 433/119

Correspondence Address:
LUNDEEN & DICKINSON, LLP
PO BOX 131144
HOUSTON, TX 77219-1144 (US)

(57) **ABSTRACT**

The present invention relates to a dental scaling translucent insert which provides a coaxially aligned light adjacent the distal end of such insert for illuminating the tip of the dental scaler which light may be provided by light emitting from a fiber optic light guide from a light source located remotely from the tip. The light provided can also be used to view through a camera lens system located in translucent insert to provide a clear unobstructed view of the work at the tip of the scaler on a remote screen or for recording.

(21) Appl. No.: **11/612,330**

(22) Filed: **Dec. 18, 2006**

Related U.S. Application Data

(63) Continuation of application No. 10/249,165, filed on Mar. 19, 2003, now Pat. No. 7,150,629.

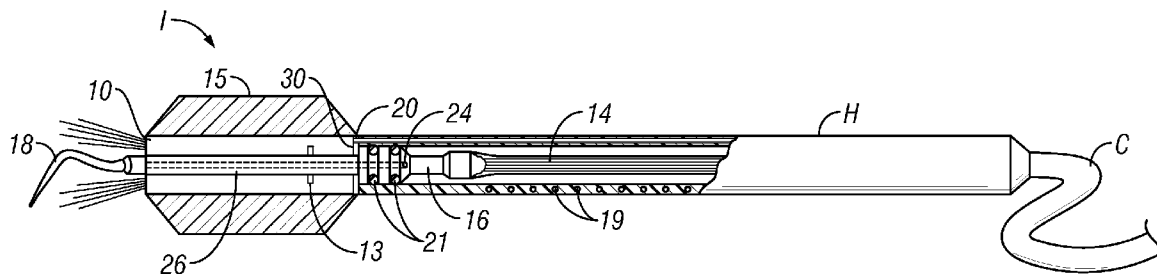

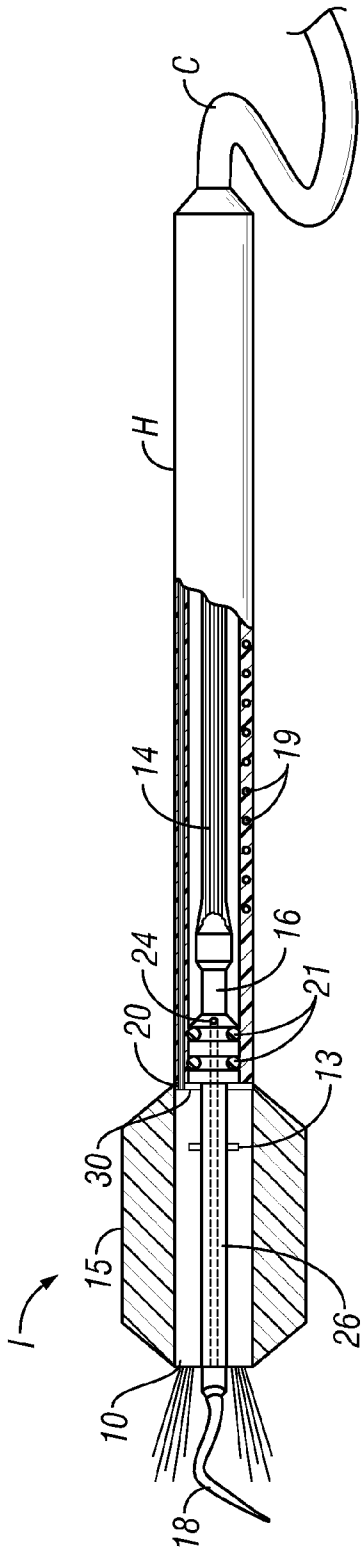

FIG. 1

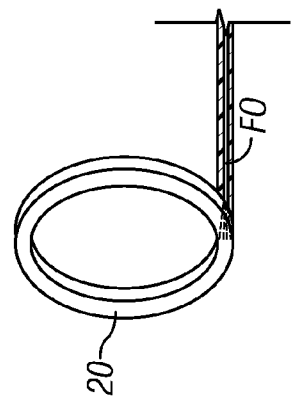

FIG. 2

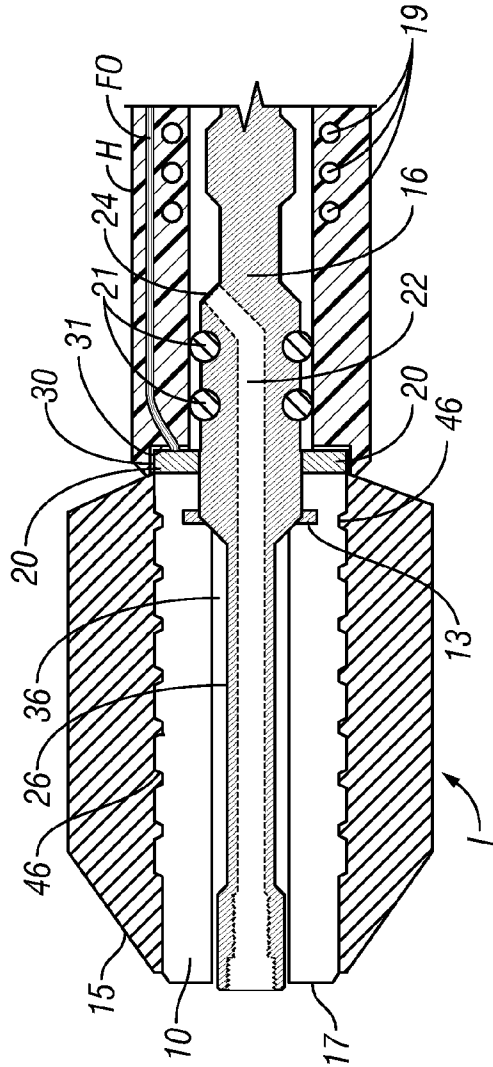

FIG. 3

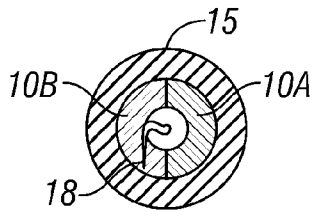

FIG. 4A

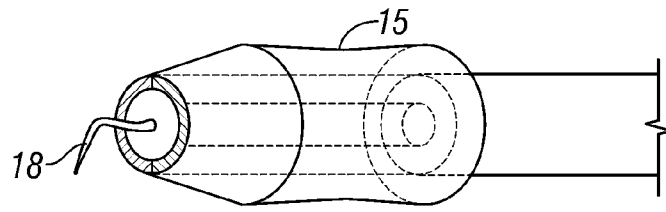

FIG. 4B

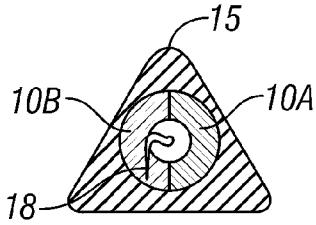

FIG. 5A

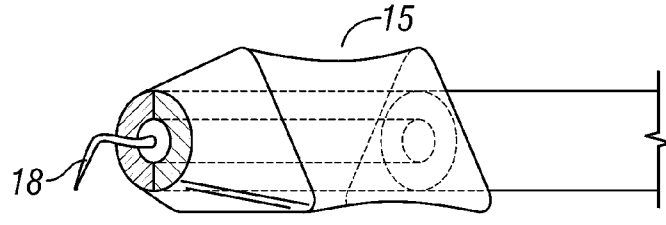

FIG. 5B

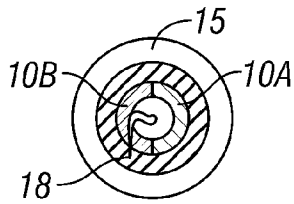

FIG. 6A

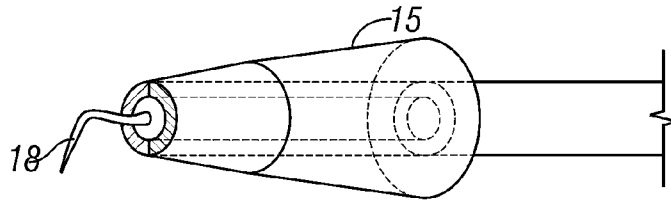

FIG. 6B

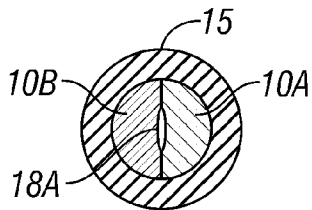

FIG. 7A

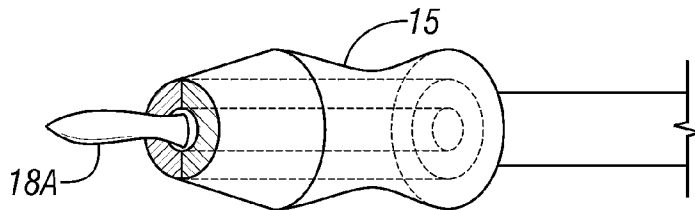

FIG. 7B

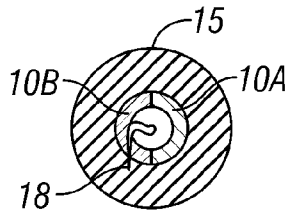

FIG. 8A

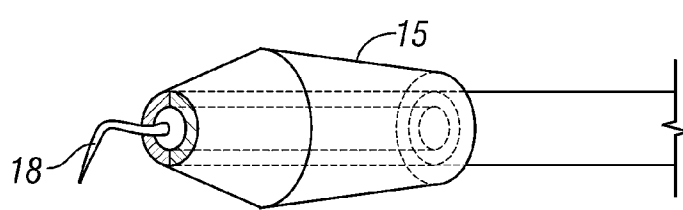

FIG. 8B

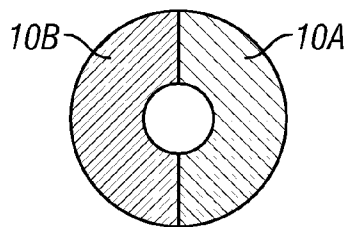

FIG. 9

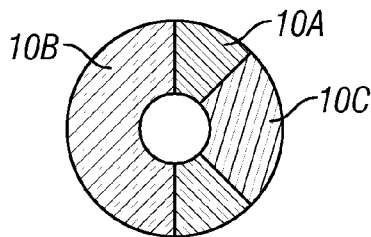

FIG. 10

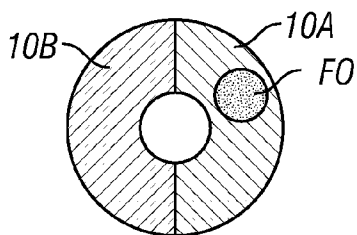

FIG. 11

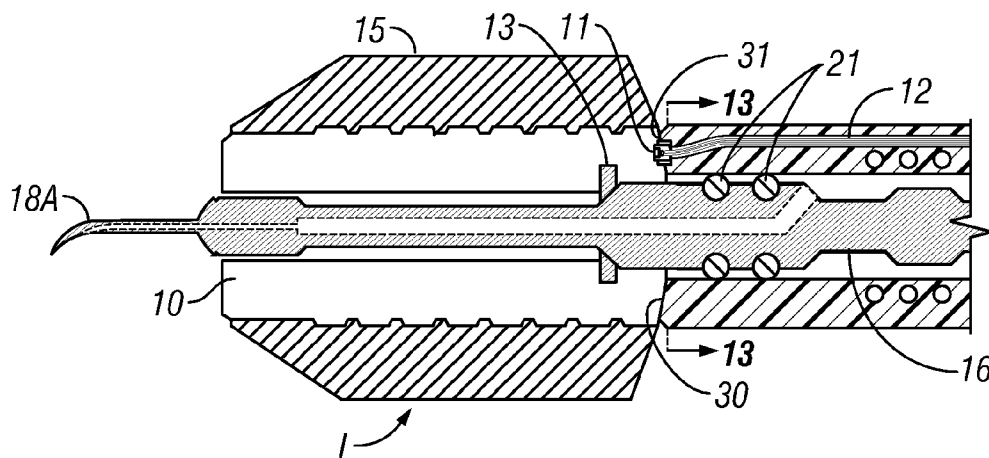

FIG. 12

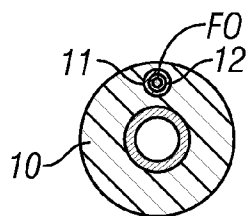

FIG. 13

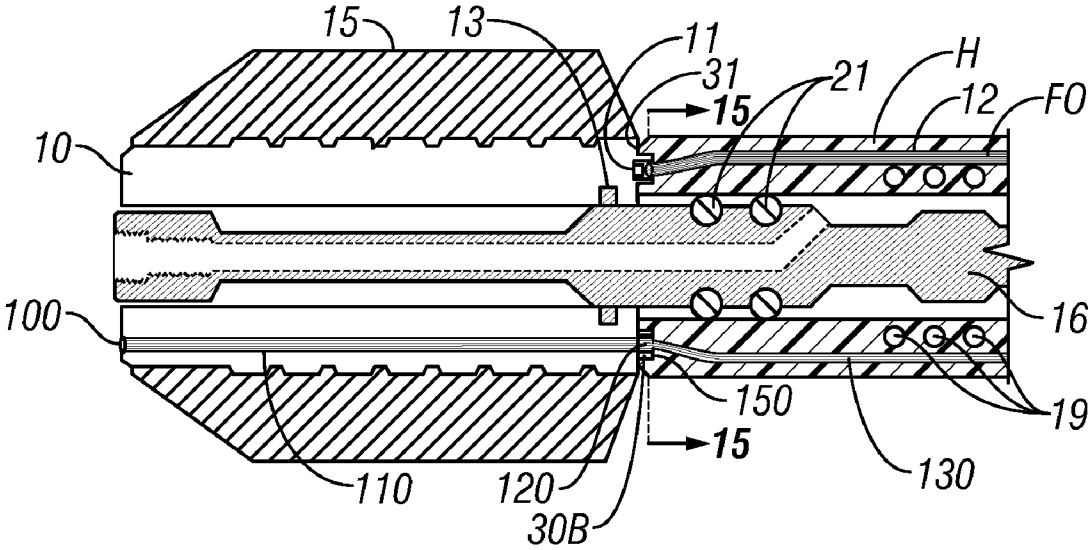

FIG. 14

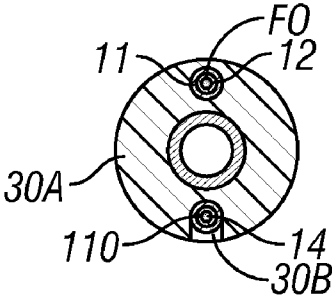

FIG. 15

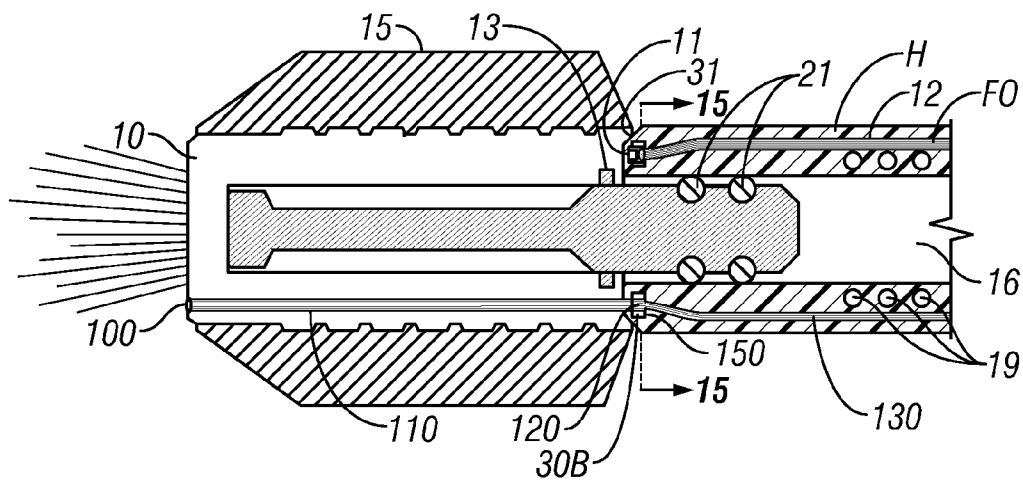

FIG. 16

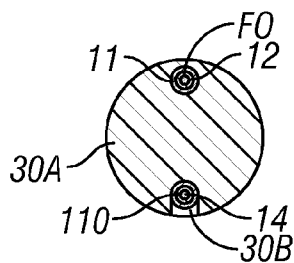

FIG. 17

**LIGHTED ULTRASONIC HANDPIECE AND
COLOR CODE GRIP SYSTEM**

**CROSS REFERENCE TO RELATED
APPLICATIONS**

[0001] This application is a continuation of U.S. Ser. No. 10/249,165 filed Mar. 19, 2003, now U.S. Pat. No. 7,150,629.

BACKGROUND OF THE INVENTION

[0002] 1. Field of the Invention

[0003] The present invention relates to a medical or dental handpiece; specifically to an ultrasonic handpiece providing a independently controlled light source connected through an interchangeable and easily identifiable grip on an ultrasonic insert adjacent the end of the handpiece for illuminating the surface to be engaged by the tip of the handpiece and which may additionally provide a camera lens for viewing the work area without interference with the work performed.

[0004] 2. Description of the Related Art

[0005] The present invention relates to an ultrasonic tool, which can be a dental scaler, or—alternatively—a scalpel, additionally providing a light directed from the handpiece of the tool toward the work surface on which the tip or blade is engaged. For ease of description, applicant discloses the dental scaling embodiment, but an ultrasonic scalpel can be fabricated from the present disclosure without departure from the coverage of this application.

[0006] Light emission from an operator's handpiece allows the operator a clear and unobstructed lighted surface on which the dental scaling tip works. This permits the operator of the scaling tip to readily see the teeth and gums or dental appliances (i.e. implants, crowns, bridges or the like) while using the ultrasonic dental scaler. Heretofore, light from an outside source such a pole mounted dental light or headlamp system shines in the back of the working area and is blocked from the working area by the hand or body of the operator or by the patient's body, tongue, or teeth. Light directed from a distal edge of the handpiece will provide the necessary illumination directly onto the working area without shadows or other impediments. Although various prior art devices disclosed mounting a light or light source in the handpiece, so far as known to applicant, no prior art provides a light path through the insert grip to guide remotely generated light to the tip of the scaler. This provides features not heretofore available in the industry. For example, the presence of a bulb in the handpiece is eliminated thereby eliminating the heat associated with this proximal light source.

[0007] Each insert tip is retained in a grip which provides a light guide which therefore remains in fixed spatial relationship with the tip to be illuminated. Since the light is driven by its own separate power supply, it may remain illuminated throughout the procedure and is not dependent upon the ultrasonic drive circuit to power the light required by other prior art devices. This feature allows the light to be used for viewing of the mouth of the patient and further allows the light to remain at a fixed intensity throughout the procedure despite variations in electrical power caused by the loading of the coil which energizes the ultrasonic stack, or piezoelectric crystal.

[0008] Since the power supply to the light source is separate and apart from the power supply to the coil in the magnetostrictive ultrasonic arrangement, there is no frequency distortion caused by the use or non-use of the lamp to interfere with the power harmonics of the coil. Finally, the inserts will always be useable with the conventional handpieces since the light source connection need not connected to a power supply to operate the magnetostrictive stack. Since the grip provides a light source, it may also provide a camera lens to capture the view of the work surface as the technician performs the necessary operation.

BRIEF SUMMARY OF INVENTION

[0009] The present invention is a lighted ultrasonic handpiece providing a dental scaling tip or alternatively a scalpel, a velocity transducer connected to said tip, an ultrasonic stack connected to said velocity transducer inserted in a grip having a longitudinally aligned light guide from a light source remote from the magnetostrictive stack insert (or an alternative piezoelectric crystal oscillator), and a light conductor connected to said light source for guiding light from a remote light source to the distal end of said insert.

[0010] The improved lighted ultrasonic dental scaling insert features a scaling tip, a velocity transducer connected to said scaling tip, an ultrasonic stack connected to said velocity transducer inserted through a grip adapted for connection with a dental scaling handpiece of the present invention. An interchangeable grip sheath can be ergonomically form fitted to more easily allow the operator to grip the ultrasonic device for long periods of time without muscle fatigue or cramping. Additionally, the interchangeable grip sheath may be color coded to permit the operator to readily identify a preferred handpiece from amongst a number of similar designed handpieces. This ability to visually determine the instrument being accessed by virtue of the color coding and the ability to use an ergonomically designed sheath adaptable to the hand of the operator fosters a less stressful clinical setting for both the dental technician and the patient.

[0011] The light source terminus in the handpiece abutts the translucent grip body and is connected to a light transmission cable permitting the transmission through the terminus into the interior of the grip covered by the sheath. A light source, which may be switched on or off and regulated to increase or decrease light intensity through the light transmission cable provides illumination through cable to the light source terminus. As previously noted, an ergonomic resilient and opaque sheath is retained over the translucent grip body to permit comfortable use of the ultrasonic device and also blocks ambient light from escaping from the translucent grip at any point except the distal end of the grip adjacent the tip.

[0012] Alternatively, the lighted ultrasonic handpiece can provide a partially translucent grip body providing a longitudinal passage through which an ultrasonic velocity transducer is connected to a tip and energized by an ultrasonic generator driving a in said handpiece having a light source terminus abutting said translucent grip body providing illumination through the grip body to a distal end of the grip body adjacent a tip and a light cable connected to said light source terminus providing illumination from a remote source to the light source terminus; and, a resilient ergo-

nomic opaque sheath covering said grip thereby preventing the light from leaving the translucent grip body at any position except its distal tip. Since the sheath may be readily and easily slip on and off the grip, it can be colored to provide visual identification to the operator of the type and configuration of the tip and light system being utilized. This facilitates easy and quick use of a number of tips for busy dental hygienists who may prefer one tip over an alternative design for a given problem.

[0013] The ultrasonic handpiece grip system of the present invention can also be fashioned with a molded body having a longitudinal passage therethrough; and, a translucent insert, such as a fiber optic channel, to transmit light from the handpiece light terminus to the grip insert, which provides an exterior surface for engaging an elastomeric opaque sheath and further providing a passage for the insertion of a velocity transducer and water path to the distal tip of the grip system and permitting the passage of light through the interior of the molded body to the distal end of the grip body to illuminate the adjacent distal tip.

[0014] Additionally, the ultrasonic handpiece grip system of the present invention can be fashioned with a lens located at the distal end of the grip and an optical image transmission path for connection to a video or photographic viewing system mounted at a remote location.

BRIEF DESCRIPTION OF THE SEVERAL VIEWS OF THE DRAWINGS

[0015] FIG. 1 is a partial cross-sectional perspective view of the dental scaling insert, grip and sheath of the present invention.

[0016] FIG. 2 is a side view perspective view of the light ring of the present invention.

[0017] FIG. 3 is a cross-sectional side view of the grip and sheath on the insert with the light ring and handpiece of the present invention.

[0018] FIG. 4A is an end view of the cylindrical sheath around the translucent insert of the present invention.

[0019] FIG. 4B is a perspective side view of the cylindrical sheath around the translucent insert of the present invention.

[0020] FIG. 5A is an end view of the triangular sheath around the translucent insert of the present invention.

[0021] FIG. 5B is a perspective side view of the triangular sheath around the translucent insert of the present invention.

[0022] FIG. 6A is an end view of the tapered backed to front sheath around the translucent insert of the present invention.

[0023] FIG. 6B is a perspective side view of the tapered back to front sheath around the translucent insert of the present invention.

[0024] FIG. 7A is an end view of the concave sheath around the translucent insert of the present invention.

[0025] FIG. 7B is a perspective side view of the concave sheath around the translucent insert of the present invention, showing a scalpel tip.

[0026] FIG. 8A is an end view of the alternative tapered front to back sheath around the translucent insert of the present invention.

[0027] FIG. 8B is a perspective side view of the alternative tapered front to back sheath around the translucent insert of the present invention.

[0028] FIG. 9 is a cross-sectional end view of the segmented insert fabricated from two translucent halves.

[0029] FIG. 10 is a cross-sectional end view of the segmented insert fabricated with a portion of one half of the insert translucent and the remaining portions opaque.

[0030] FIG. 11 is a cross-sectional end view of the segmented insert fabricated with a fiber optic pathway to transmit light from the light ring to the distal end of the insert.

[0031] FIG. 12 is a cross-sectional side view of an alternative bayonet light connector having a male and a female connector.

[0032] FIG. 13 is a cross-sectional end view of the alternative bayonet light connector of FIG. 12.

[0033] FIG. 14 is a cross-sectional side view of an alternative embodiment of a lens system mounted in the grip system of the present invention to permit the transmission of images of the work surface to a remotely located camera or video display system.

[0034] FIG. 15 is a cross-sectional end view of an alternative embodiment of the lens support system of FIG. 14 above.

[0035] FIG. 16 is a cross-sectional view of a camera lens snub assembly which allows the camera to be used at the end of a standard ultrasonic dental appliance for recording or viewing the work without being encumbered by the tip system.

DETAILED DESCRIPTION OF THE INVENTION

[0036] The present invention relates to a dental scaling insert providing a translucent path from a light source to the end of the handpiece through a translucent grip covered by an ergonomically designed resilient sheath. In a preferred embodiment shown in FIG. 1, insert system I is comprised of a magnetostrictive stack 14 typically formed of nickel or nickel alloy plates in a manner well known to those skilled in this art, which are soldered together and which respond to electrical energy supplied by coil 19 encircling stack 14 in the handpiece H. Stack 14 is connected to a velocity transducer 16 which is connected to a scaling tip 18 and which is covered with grip 10. Grip 10 is formed from two segments or pieces of high grade plastic, for example, such as a polycarbonate, that provide a profile on their interior surface to retain the velocity transducer 16. In this embodiment, one or more teeth 13 are provided on the exterior lateral surfaces of the velocity transducer 16 to prevent rotation of the velocity transducer in the interior passage of the grip 10. Velocity transducer 16 may be integral with scaling tip 18 or may be threaded to provide threaded connection with scaling tip 18. Velocity transducer 16 provides a longitudinal pathway 26 for the delivery of water through port 24 in transducer 16 to scaling tip 18.

[0037] The handpiece H is connected with cable bundle C which provides the electrical connection to the remote power supply (not shown) to drive the magnetostrictive insert, a water supply to cool stack 14 and rinse the affected area in the patient's mouth or gum being cleaned through the water pathway 26, and to the light source by either fiber optic cabling FO or liquid light cabling (not shown).

[0038] Translucent grip 10 provides a light path for light provided at its proximal end 30 by light ring 20 to a distal end of grip 10 where the light emitted is adjacent the tip of dental scaler 18. Light ring 20 is positioned adjacent the proximal end of translucent grip 10 and retained there by a recessed lip 31 in handpiece H, as more closely described in FIG. 3. Insert 10 is compressively engaged in the handpiece H with one or more O-rings 15 as more clearly shown in FIG. 3.

[0039] FIG. 2 more clearly demonstrates a method of connecting a fiber optic cable FO to the light ring 20, which is held adjacent the proximal end 30 of the insert 10. The fiber optic cabling FO is splayed and the individual fibers are affixed to a lateral edge of the light ring 20. An epoxy can be used to attach the ends of the fiber optic FO individual fibers to the ring 20. An alternative embodiment of the light delivery system is disclosed in FIGS. 12 and 13.

[0040] Insert grip alone 10 is hard and difficult to hold over an extended period of time. Accordingly, a sheath 15 is engaged over the translucent grip 10 to provide a larger diameter material that is more readily conformable to the hand of the operator to reduce the fatigue associated with long extended treatment processes. This sheath can be manufactured using many types of sterilizable soft or semi-soft materials such as silicon rubber. The color and hardness of the material of sheath 15 can be controlled during the manufacturing process or molding of the sheath by selection of appropriate color and durometer raw material for the fabrication of the sheath. The ColorID® system of the applicant, as more fully described in U.S. Pat. No. 6,328,566, which is incorporated herein by reference as if fully copied herein, can be coordinated in this grip system to provide an easily identifiable system of scaling tip and shape to the dental hygienist.

[0041] Additionally, sheath 15 can be fabricated to provide a number of differing shapes of exterior surfaces to conform more ergonomically to the hand and preference of the dental hygienist. A variety of shapes will be more fully described herein. To retain sheath 15 on grip 10, the exterior surface of grip 10 can be roughened or ribbed 46 to provide resistance to movement of the sheath on the grip. Since sheath 15 is resilient, the operator will slip the desired shape and color on grip 10 and the roughened or ribbed exterior surface 46 of the grip will allow sheath 15 to remain fixed on grip 10 without substantial movement.

[0042] Sheath 15 can also be installed by slipping it over other manufacturer's ultrasonic inserts to give the operator the ability to use the ColorID® system to identify the insert for the hygienist. Since sheath 15 can be readily slipped on and off the grip 10 of the present invention, any number of differing color schemes and shapes may be used by the operator to suit the operator's preferences. The sheath may be marketed in assorted packages or ordered in one preferred color and style as the hygienist prefers. Once received the sheaths may be inserted over the grip 10, sterilized and used by the hygienist.

[0043] As may be readily appreciated from FIG. 11, grip 10 can be fabricated to also provide a similar path for a light guide in the form of a fiber optic bundle. The use of a remote light source and control circuit eliminates the need for a light emitting diode or incandescent bulb in the grip or handpiece, but still allows the light to remain on without power being used in the scaler tip. The remote control circuit contains a heat sink, miniaturized ballast and ultrasonic generator circuitry (which can be either for driving a magnetostrictive or a piezoelectric device) and a circuit for powering and control a high intensity light system. An incandescent bulb, a quartz halogen arc or a high intensity light emitting diode lamp or any other high intensity light emission source may be adapted for use in the remotely located source and can be independently monitored by the circuitry of the remote control device which can provide an automatic shutoff after detection of either a period of inactivity of the ultrasonic circuitry or dangerous temperature build up in the lamp section, or both. A rheostat can also be provided in the remote power supply to adjust the level of intensity of the light delivered to the distal tip end of the ultrasonic device. Each of these enhancements are readily accomplished by a person having ordinary skill in this art field. Since the light source is operated independent of the dental scaling handpiece, the control may also provide means for permitting the attachment of a headlamp for the use of the operator. Light is delivered to the handpiece H by either a fiber optic cable bundle FO, or by a liquid light guide cable (not shown), such as may be obtained from Rofin Australia Pty, Ltd., for example. Additionally, as more fully described subsequently in this application, an alternative embodiment can be provided with a lens and cable connection affixed in the grip to permit imaging of the process at the tip of the dental scaler.

[0044] FIG. 3 discloses the perspective view of the light ring of the present invention showing light ring 20 connected to a multi-stranded fiber optic cable FO which runs through handpiece H of FIG. 1 with each of such fibers being attached to the exterior lateral surface of the light ring. Light ring 20 provides an outer diameter which fits inside a groove 31 provided in handpiece H adjacent the proximal end 30 of translucent insert or grip 10. The light from the light source reaches the light ring 20 and is diffused throughout the ring and thereby transmitted to the translucent insert or grip 10. The light is thereby transmitted through insert 10 to the exposed distal end of the insert system I to provide light to the work surface adjacent the tip 18. Sheath 15 covers the grip to allow the operator to comfortably hold the ultrasonic scaling device. FIG. 3 shows insert 10 with a threaded velocity transducer 16 to permit the interchange of scaling tips to the velocity transducer in an alternative manner.

[0045] FIG. 4A is an end view of an alternative cylindrical form of sheath 15 mounted on conjoined inserts 10A and 10B which support scaling tip 18 on velocity transducer 16 (not seen in this view). FIG. 4B is a side view of the cylindrical sheath 15.

[0046] FIG. 5A is an end view of another alternative triangular form of sheath 15 mounted on the conjoined inserts 10A and 10B which support scaling tip 18 on velocity transducer 16. FIG. 5B is a side view of triangular sheath 15.

[0047] FIG. 6A is an end view of another alternative tapered conical form of sheath 15 mounted on the conjoined

inserts **10A** and **10B** which support scaling tip **18** on velocity transducer **16**. FIG. **6B** is a side view of the tapered conical form of sheath **15**.

[**0048**] FIG. **7A** is an end view of another concave form of sheath **15** mounted on the conjoined inserts **10A** and **10B** mounting a scalpel blade **18A** on the end of the velocity transducer. FIG. **7B** is a side view of this form of sheath **15** showing the scalpel blade, which is an alternative use of the present invention.

[**0049**] FIG. **8A** is an end view of another view of a tapered conical form of sheath **15** showing a taper from large at the distal end to small at the proximal end. FIG. **8B** is a side view of this alternative tapered conical form of sheath **15**.

[**0050**] As previously noted, the insert system I of the present invention can provide a number of alternative arrangements which remain within the scope and intent of the present disclosure. For example, FIG. **9** shows an end view of two halves of the translucent polycarbonate insert body that are ultrasonically welded together to form insert **10**. As previously noted, the interior surface of the two halves provides a profile to retain velocity transducer **16**. Alternatively, as shown in FIG. **10**, a portion of one half of insert **10** can be fabricated translucent with the remainder opaque. Portions **10A** and **10B** could be fabricated as translucent polycarbonate or any other well known materials while portion **10C** is opaque, to reduce the amount of light reaching the distal tip of insert **10**. Conversely, portion **10C** may be fabricated as translucent and portions **10A** and **10B** can be fabricated as opaque. Additionally, as shown in FIG. **11**, fiber optic bundle FO can be laid in a portion of the insert shell **10A** that is then conjoined with portion **10B** to form an insert. The fiber optic bundle would allow the light transmission to flow from the remote lamp to the distal end of the insert system I. Other arrangements may be derived from this disclosure without departing from the spirit of this disclosure or the invention disclosed herein.

[**0051**] Another embodiment permitting the connection of the fiber optic bundle FO through a bayonet connection **12** in handpiece H to a female receptacle **11** in insert **10** is disclosed in FIG. **12**. Insert **10** (shown without a velocity transducer **16**) is fashioned with female receptacle **11**, which mates with male bayonet end **12** of the fiber optic bundle FO. Light is transmitted through the fiber optic cabling to the insert after handpiece end **31** is brought into mating arrangement with the proximal surface **30** of insert body **10**.

[**0052**] FIG. **13** is a partial end view of bayonet end **12** of the fiber optic FO cabling showing the relative location of the bayonet with the central core of the handpiece H. The interior of said bayonet connection **12** is filled with the terminus ends of the fiber optic cable fibers.

[**0053**] FIG. **14** is a cross-sectional view of an alternative embodiment of the lighted ultrasonic handpiece and grip system with camera lens and optical pathway. As can be appreciated, mounting a camera lens system **100** and connecting such camera lens through a return fiber optic cable bundle **110** permits the hygienist to view the area around the tip on a large screen. Since the lighting provided is adequate to illuminate the work area, the hygienist can record or permit other dental health care providers to view the scaling activity and to view the health of the gums and teeth adjacent the dental scaling tip. Utilizing the system as an ultrasoni-

cally driven scalpel would permit the surgeon to permit colleagues to view the incision being made in real time at the tip of the scalpel.

[**0054**] FIG. **14** discloses a cross-sectional view of the grip assembly providing a male-female bayonet connection (**11**, **12**) for the fiber optic light guide FO into the translucent grip body **10** and a fiber optic link bayonet connection **120-30B** to the camera lens **100** and integrated fiber optic fiber or endoscopic tubing **110** disposed in grip **10**, providing a connector **120** to convey images obtained by the lens **100** from the space adjacent the distal end of grip **10** to the fiber optic bundle **130** for processing by the imaging portion of the camera contained within the remote control device not shown. The provision of a CCD or other optical device to capture the image provided by a remote lens/fiber optic cable system is well known technology to those skilled in the art of making and using dental and medical equipment.

[**0055**] FIG. **15** is an end cross-sectional view of the light providing handle H providing bayonet connections for both the light delivering fiber optic FO bundle (**11-12**) to the grip system and the lens providing imaging (**100-110-30B**). When connected to the grip the light providing introduces an appropriate level and frequency of light into grip **10** for illumination of the distal end of the grip and the camera lens **100** obtains and permits an image to be returned through grip **10** in fiber optic cable or endoscopic tube **110** to connector **120** which mates with receptacle **30B** which is connected to fiber optic cable **130** for return to the control box containing the image processor. A variety of viewing angles may be chosen from 0° (straight ahead) to 90° (at a right angle to the longitudinal axis of the insert).

[**0056**] In the embodiment of tubing **110** inserted into grip **10**, connector **120** mates with the tube through connector **30B** in the light ring **30A**. Other methods of providing a path to and a connection with the fiber optic cabling FO can be provided without departing from the spirit or intent of the present disclosure.

[**0057**] Further, it may be useful to provide a lighted camera which may be readily held by the hygienist for viewing the gums, teeth or other portions of the mouth either before or after the procedure. FIG. **16** discloses an alternative embodiment of the present lighted handpiece which provides a lighted insert **10**, with sheath **15**, inserted in handpiece H of a standard ultrasonic scaler, but which only provides a light path and camera lens and optical system for viewing the work area unimpeded by the presence of the tip system. The grip **10** is closed at its distal end providing sufficient light for the camera lens **100** to gather an unobstructed view of the gums which is returned to the optical system through fiber optic cabling **110** to the handpiece and its fiber optic cabling **130**.

[**0058**] One skilled in the art will realize that the embodiments disclosed are illustrative and that the scope and content of the invention is to be determined by the scope of the claims.

What is claimed is:

1. An ultrasonic apparatus comprising:
 - an ultrasonic driver connected to a velocity transducer;
 - an annular translucent insert disposed on the velocity transducer; and

a light source abutting a proximal end of the annular translucent insert.

2. The ultrasonic apparatus of claim 1 further comprising an opaque sheath over the annular translucent insert.

3. The ultrasonic apparatus of claim 1 wherein the annular translucent insert is formed with one or more fiber optic bundles running therethrough.

4. The ultrasonic apparatus of claim 2 wherein the annular translucent insert provides external ridges to inhibit movement of the opaque sheath positioned thereon.

5. The ultrasonic apparatus of claim 2 wherein the annular translucent insert provides an indented external surface to restrain movement of the opaque sheath retained thereon.

6. The ultrasonic apparatus of claim 1 wherein the velocity transducer is connected to a scaling tip.

7. The ultrasonic apparatus of claim 1 wherein the velocity transducer is connected to a scalpel.

8. The ultrasonic apparatus of claim 1 wherein the ultrasonic driver is a magnetostrictive stack device.

9. The ultrasonic apparatus of claim 1 wherein the ultrasonic driver is a piezoelectric crystal device.

10. The ultrasonic apparatus of claim 1 wherein the annular translucent insert provides a light path from the proximal end to a distal end of the annular translucent insert.

11. The ultrasonic apparatus of claim 1 wherein the annular translucent insert is an at least partially translucent annular insert.

12. The ultrasonic apparatus of claim 1 wherein the velocity transducer is optically opaque.

13. The ultrasonic apparatus of claim 1 wherein the annular translucent insert further provides a camera lens on

a distal end optically connected through the annular translucent insert to the proximal end.

14. The ultrasonic apparatus of claim 14 wherein an optical connection in the annular translucent insert and a fiber optic bundle are mated to permit transmission of images from the camera lens to a remote image processing system.

15. An ultrasonic handpiece grip comprising:

a molded grip body having a longitudinal passage there-through; and

a light guide comprising an annular translucent insert disposed on a velocity transducer and providing an exterior surface for engaging the molded grip body within the longitudinal passage and permitting passage of light through the molded grip body to a distal end of the molded grip body.

16. The ultrasonic handpiece grip of claim 16 wherein the velocity transducer is optically opaque.

17. The ultrasonic handpiece grip of claim 16 wherein the molded grip body is an interchangeable, user-selected, molded grip body.

18. The ultrasonic handpiece grip of claim 16 wherein the molded grip body is selectively colored for visually distinguishing the ultrasonic handpiece grip from a similar handpiece grip having a differing colored exterior surface.

19. The ultrasonic handpiece grip of claim 16 wherein the annular translucent insert further provides a camera lens on a distal end optically connected through the annular translucent insert to a proximal end.

* * * * *