

E. H. JOHNSON.
MACHINE FOR MAKING TOOTHPICKS.

(Application filed July 27, 1898.)

(No Model.)

3 Sheets—Sheet 1.

Fig. 1.

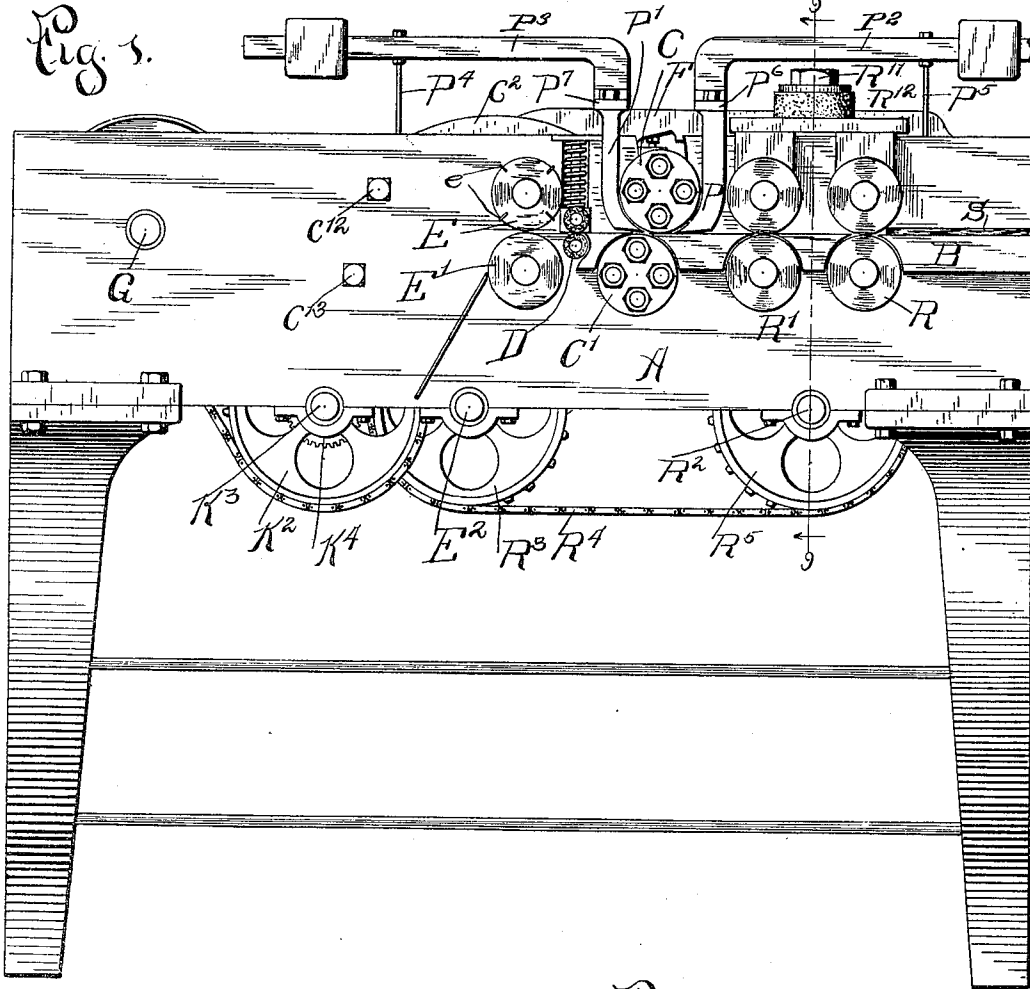

Fig. 3.

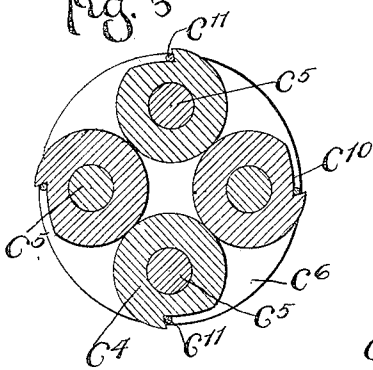
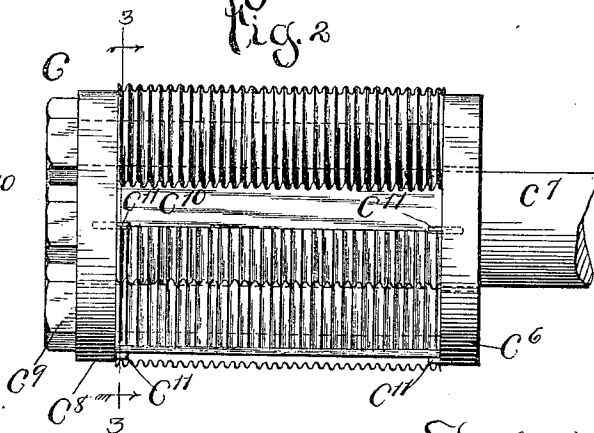

Fig. 2.



Witnesses
 Frank W. Murphy,
 B. A. Raymond.

Inventor:
 E. H. Johnson
 By W. Williams
 atty

E. H. JOHNSON.
MACHINE FOR MAKING TOOTHPICKS.

(Application filed July 27, 1898.)

(No Model.)

3 Sheets—Sheet 2.

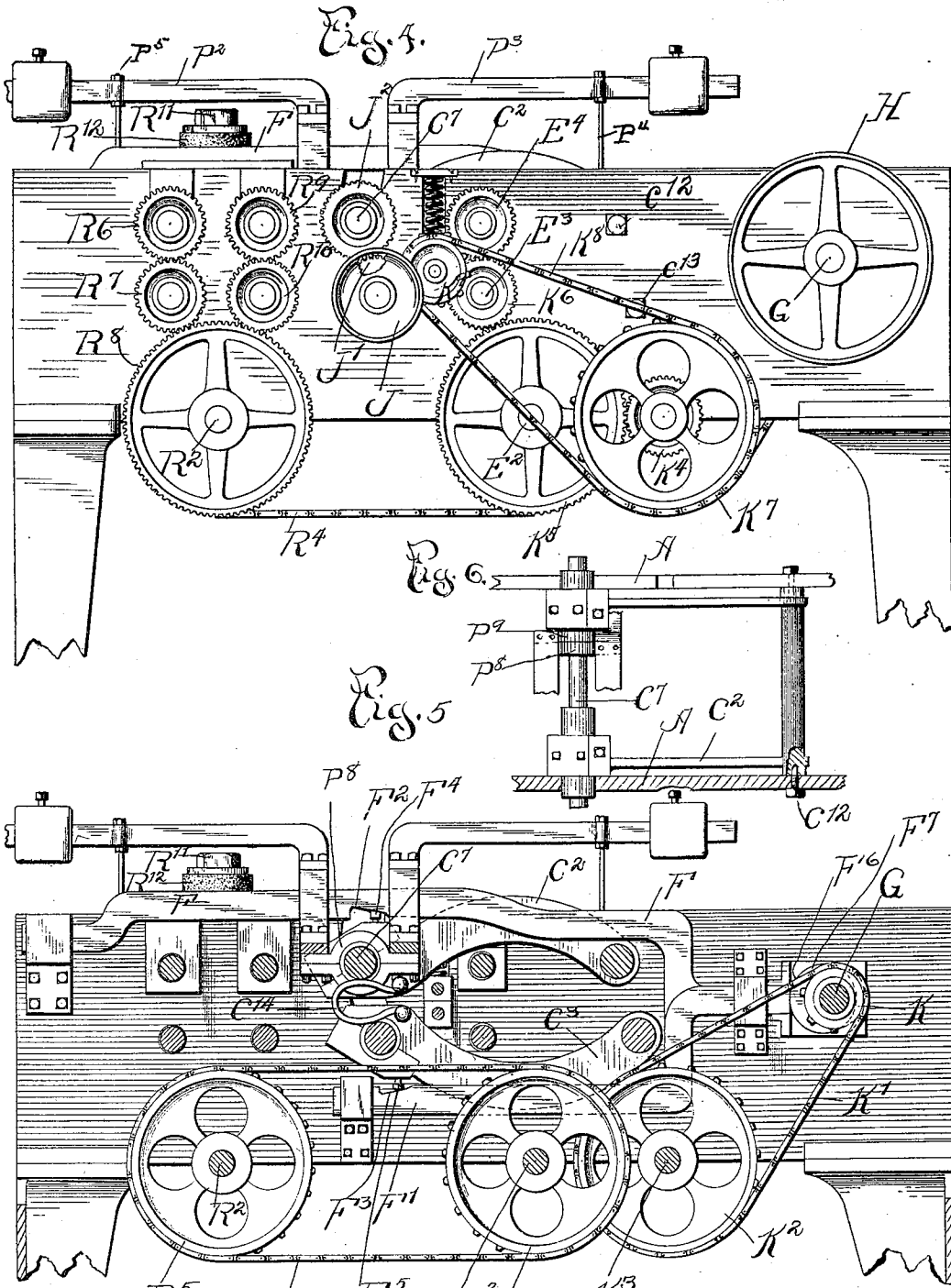

Witnesses:
 Frank W. Murphy
 R. A. Raymond

Inventor:
 E. H. Johnson
 By W. E. Williams
 atty

E. H. JOHNSON.

MACHINE FOR MAKING TOOTHPICKS.

(Application filed July 27, 1898.)

(No Model.)

3 Sheets—Sheet 3.

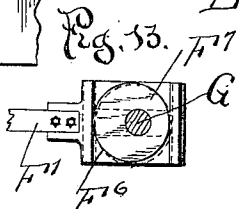
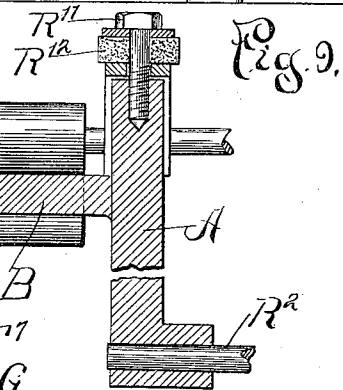
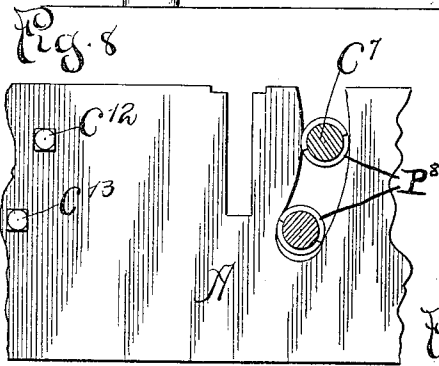
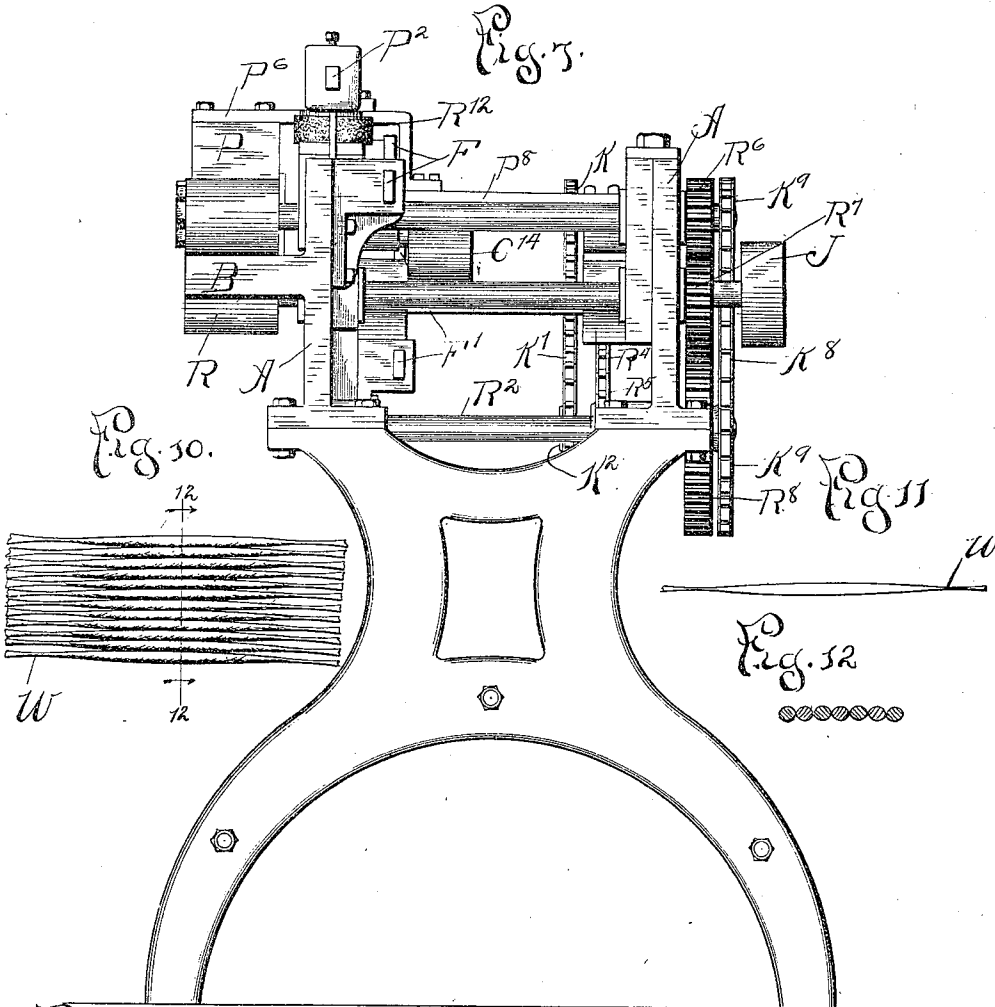

Witnesses:
 Frank W. Murphy
 B. A. Raymond

Inventor:
 E. H. Johnson
 By N. E. Williams
 atty.

UNITED STATES PATENT OFFICE.

EDGAR H. JOHNSON, OF MARION, INDIANA, ASSIGNOR TO THE JOHNSON MANUFACTURING COMPANY, OF INDIANA.

MACHINE FOR MAKING TOOTHPICKS.

SPECIFICATION forming part of Letters Patent No. 654,260, dated July 24, 1900.

Application filed July 27, 1898. Serial No. 687,001. (No model.)

To all whom it may concern:

Be it known that I, EDGAR H. JOHNSON, a citizen of the United States of America, and a resident of Marion, Grant county, Indiana, have invented certain new and useful Improvements in Machines for Making Toothpicks and Butchers' Skewers, of which the following is a specification.

The object of my invention is to produce a machine that will manufacture a toothpick or a butcher's skewer which will be smooth throughout its entire length and will be pointed at both ends; and the invention consists in the novel construction of the parts and devices and the novel combination of the parts and devices, as is set forth in the claims thereof.

Reference will be had to the accompanying drawings, in which—

Figure 1 is a side elevation of the working side of the machine. Fig. 2 is an enlarged detail view of one of the cutter-heads. Fig. 3 is a transverse sectional view of Fig. 2. Fig. 4 is a side elevation of the gearing side of the machine. Fig. 5 is a vertical sectional elevation of the machine. Fig. 6 is a plan detail of one of the arms which carry the cutter-head shafts. Fig. 7 is an end view of the end from which the stock is supplied to the machine. Fig. 8 is a detail section of the frame. Fig. 9 is a transverse detail of the section of the frame. Fig. 10 is a detail showing the method of cutting the picks from the stock. Fig. 11 is a side view of Fig. 10. Fig. 12 is a view on line 12 12 of Fig. 10. Fig. 13 is a detail of one of the eccentrics.

The wood S, from which the picks are to be cut, is prepared in long flat strips of suitable width and thickness, and it is fed to the machine upon the table or bracket B and is engaged and fed forward by two sets of positively-driven feed-rollers R and R', which feed the strips to the cutter-heads C and C', which are mounted in arms C² and C³, pivoted in the frame and are moved to and from the stock-strip while the cutters are acting upon it. The cutters of the cutter-heads are so shaped that they cut the stock-strip into small longitudinal strips, as is shown by Figs. 10, 11, and 12, and the movement of the heads to and from the stock causes the cutters at

intervals to cut deeper into the stock, causing the bottoms of the grooves of the cutters to cut away almost entirely the stock-strip at certain points, (indicated by W.) After passing the cutter-heads the strips are drawn forward gently by the rubber-faced feed-rolls D, which deliver the strips to the cutting-off rollers E and E', which are positively driven and so timed that the cutting-blades e always cut the strips at the points W, which completes the picks.

The cutter-heads C and C' are offset from each other a little at the line of contact with the stock-strip S to permit the cutters' edges to pass through the stock-strip without coming in contact with the cutters of the other head and to allow a presser-foot to hold the stock while the cutters are doing their work.

The movement of each cutter-head to and from the stock-strip is so timed that the swells and depressions on each side of the stock-strip are opposite to each other, and in connection with this movement the roller E, with its cutter-blades e, is positively timed to cut the strips at the points W. The stock-strip S is engaged on each side of the cutter-heads C and C' by the presser-feet P and P', which are held in contact by the weighted levers P² and P³, provided with stops P⁴ and P⁵, resting upon the frame. Presser-foot P' follows the swells and depressions in the stock-strip made by cutter C and also serves as a plate for the lower cutter C' to cut against.

The cutter-heads are made each of four circular grooved cutters C⁴, mounted upon spindles C⁵, held in a plate C⁶ upon the shaft C⁷. A plate C⁸ fits over the ends of the spindle and is made to clamp the cutters by the nuts C⁹. The circular cutters C⁴ are notched or cut away at C¹⁰ to produce a cutting edge, and pins C¹¹ are fixed into the plate C⁶, to which the cutting edges of the cutters are always set. This form of cutter has many merits. The several cutters are turned accurately alike, and then the notches are milled out and the cutters hardened and ground and then slipped on the spindles and set to the pins and clamped, and thus they are always balanced, and when dull the four cutters are taken off and slipped upon one spindle, bringing their cutting edges in line, and they then

may be ground all alike, preserving the balance, and as the cutting edge wears away the block is revolved, and thus the whole stock of the cutter-block can be used without a new turning or alteration of the grooves or shape of the cutting-face.

The arms C² and C³, which support and carry cutter-head shafts, are pivoted in the frame by the conical-pointed screws C¹² and C¹³, and the movement of the arms in carrying the cutter-heads toward the stock is produced by the longitudinally-moving bars F and F', provided with the inclined surfaces F² and F³, acting against the screws or stops F⁴ and F⁵, fixed in the arms C² and C³. Surfaces F² and F³ are shaped to give the desired form to the article being made. The longitudinal movement of the bars is produced by the eccentrics F⁶ and F⁷, fixed upon shaft G. The arms C² and C³ are moved away from the strip-stock by the spring C¹⁴.

The presser-feet P and P' are fixed to bars P⁶ and P⁷, which are bent downward and are fastened to two sets of split collars P⁸ and P⁹ upon the inner ends of the boxes of the arms which carry the cutter-head shaft for the cutter-head C, and the ends of these boxes are made round for this purpose and also for passing through the frame members. (See Fig. 8.) Thus the presser-feet P and P' are pivoted upon a center corresponding to the axis of cutter-head C.

Power is applied to the shaft of the cutter-head C' by the pulley J, and a gear J' on this shaft engages and drives a gear J² on shaft of cutter-head C. Power is also applied to the machine by belt-wheel H and driving-shaft G, and shaft K³ is driven from shaft G by the sprocket K, chain K', and sprocket K². Shaft K³ drives the rubber feed-rolls through the medium of the sprocket K⁷, chain K⁸, and sprocket K⁹ on the shaft of one of the rolls, the other roll being driven from this shaft by a set of small gears hidden by sprocket K⁹. Shaft K⁸ also drives shaft E² through the medium of gear K⁴ and gear K⁵, and gear K⁵ drives gear K⁶ upon shaft E³, which is shaft of roll E', and cutting-off roll E is driven by gear E⁴ engaging gear K⁶. The shaft E² drives shaft R² through the medium of sprocket R³, chain R⁴, and sprocket R⁵, and shaft R² drives the feed-rolls R and R' through the medium of the gears R⁶, R⁷, R⁸, R⁹, and R¹⁰.

The two sets of feed-rolls R and R' are held in elastic connection with the stock S by the screw R¹¹ engaging a rubber block R¹², bearing upon a block in contact with the boxes of the roll-shafts. The two sets of rolls are provided in order to insure a positive feed of the stock-strip, that it may register properly with the cutter-heads and cutting-off rolls.

In place of the devices, means, or mechanism that I have shown to perform the work I may use any device, means, or mechanism suitable for the purpose, as described, and many parts and devices of my invention may be used with other machines varying widely

from the machine here shown, and I desire to be protected in any application that may be made of them.

What I claim is—

1. The combination of a table, a positively-driven, rotary, vertically-adjustable corrugating cutter-head above the table, means to force a stock-strip beneath said cutter-head, presser-feet pivotally supported by the cutter-head shaft and acting beneath the cutter-head upon opposite sides thereof, and a second similar cutter-head projecting from below through the table and acting beneath one of said presser-feet.

2. The combination with the stock-feeding rollers, of the corrugating cutter-heads one slightly in advance of the other, a rotary transverse cutter parallel to the rollers and cutter-heads and at a short distance from the latter, means for continuously rotating the feed-rollers and cutter-heads, means for causing the cutter-heads to gradually approach and recede within the path of the stock at regular intervals corresponding to pick-length advances of the stock, and means for advancing the formed stock to the transverse cutter.

3. The combination of a corrugating cutter-head mounted upon a laterally-moving shaft, a presser-foot pivotally supported by said shaft and acting at one side of its vertical plane, and means to yieldingly urge the rotation of the presser-foot about the shaft, whereby the presser-foot while moving bodily with the shaft may yet always press upon the work beneath the cutter.

4. The combination of a laterally-moving shaft carrying a rotary cutter-head, a presser-foot pivotally supported by said shaft and working at one side of its vertical plane, an arm connected to the presser-foot, a weight adjustable upon said arm and tending to swing the presser-foot to its work, and a stop limiting the swinging.

5. The combination of cutter-heads revolvably mounted in the free ends of arms pivotally fixed at their opposite ends and forming with the cutter-heads swinging members, longitudinally-movable bars having inclined surfaces, adjustable stops projecting from said members against said inclined surfaces, respectively, and eccentrics arranged to slide each of said bars back and forth at regular intervals.

6. The combination with continuously-rotating, corrugating cutter-heads, of means for feeding flat stock-strips between the cutter-heads, and means for causing the cutter-heads to gradually approach and retreat while acting upon the strip; whereby the continuously-moving strip is formed into successive transverse sets of gradually and oppositely tapering picks.

7. In a toothpick-machine the combination with means for constantly feeding a strip many times longer than a pick, of rotary corrugating-cutters arranged to act continuously to form the strip longitudinally into parallel

rods, means for causing the cutters to gradually approach and recede at regular intervals, within the path of the stock, whereby each rod is gradually varied in diameter and
5 formed into a succession of picks connected end to end, and cut-off devices arranged to separate the advancing picks so formed.

8. The combination with mechanism to feed a stock-strip positively and continuously, of
10 two rotary corrugating cutting-heads acting, one slightly in advance of the other, upon opposite sides of the strip, means for gradually moving the cutter-heads toward and away

from each other and within the path of the strip to vary the amount cut therefrom, and
15 a cut-off device arranged to sever transversely at proper intervals that portion of the strip left by the cutter-heads, said mechanism, means and device being positively timed each
20 with reference to each of the others.

Signed by me at Marion, Indiana, this 21st day of July, 1898.

EDGAR H. JOHNSON.

Witnesses:

WILL H. TROOK,
RALPH H. JOHNSON.