

(No Model.)

3 Sheets—Sheet 1.

J. H. PIERCE.
WATER FILTER.

No. 583,236.

Patented May 25, 1897.

Fig. 1.

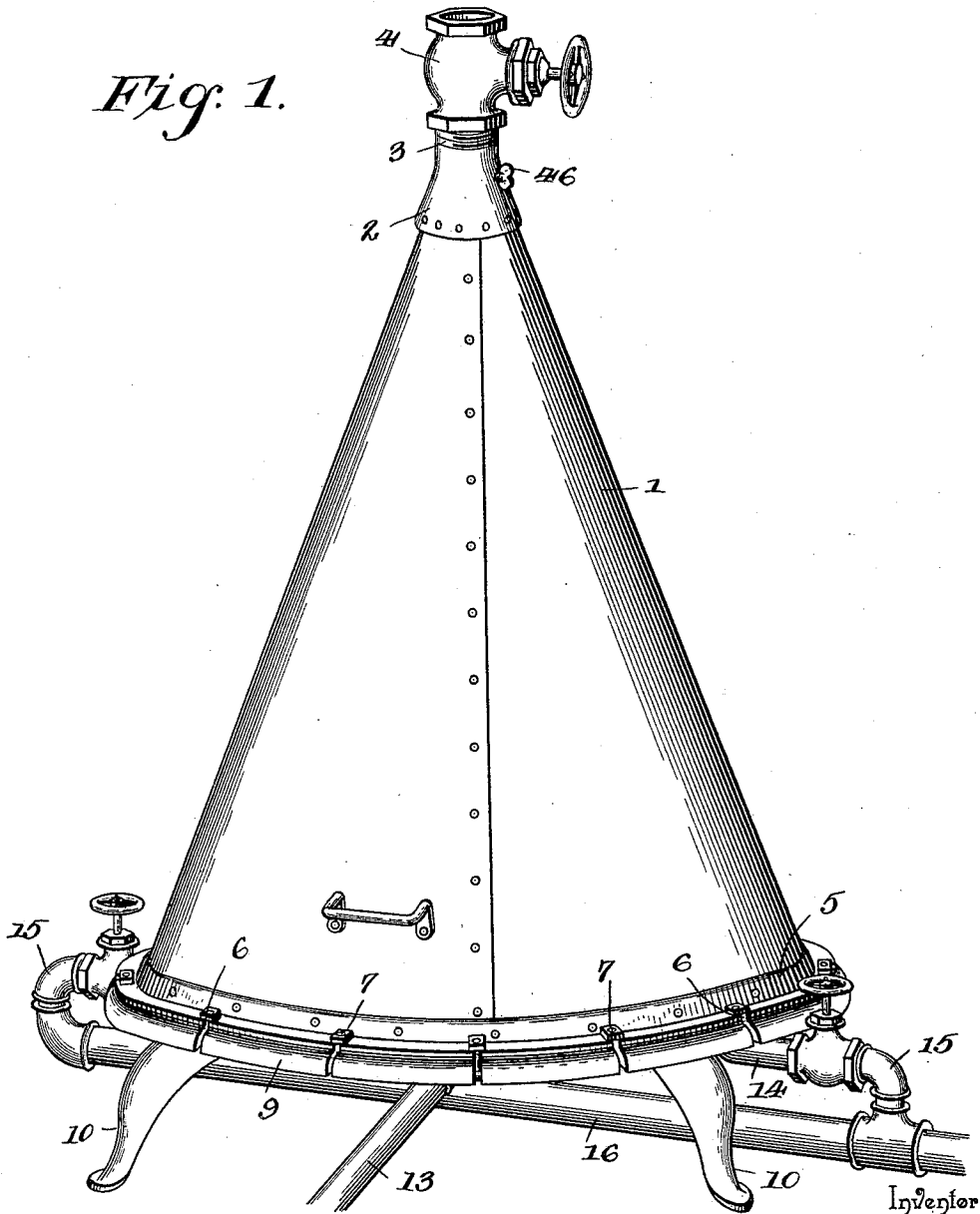

Inventor

Witnesses

Chas. A. Ford.
S. P. Holhauser.

By *his* Attorneys,

C. A. Snow & Co.

Joseph H. Pierce,

J. H. PIERCE. WATER FILTER.

No. 583,236.

Patented May 25, 1897.

Fig. 5.

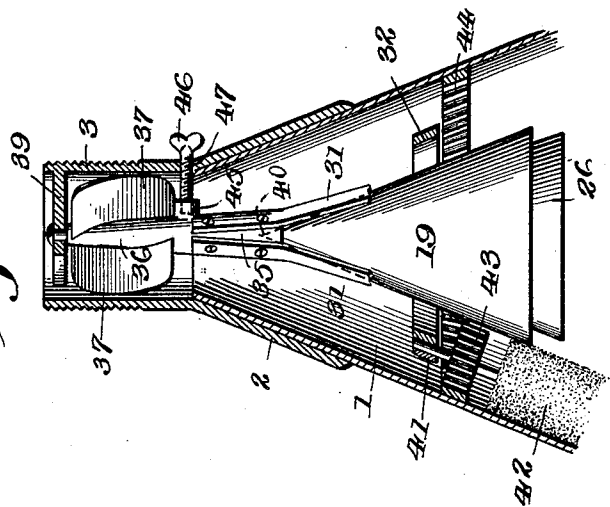

Fig. 2.

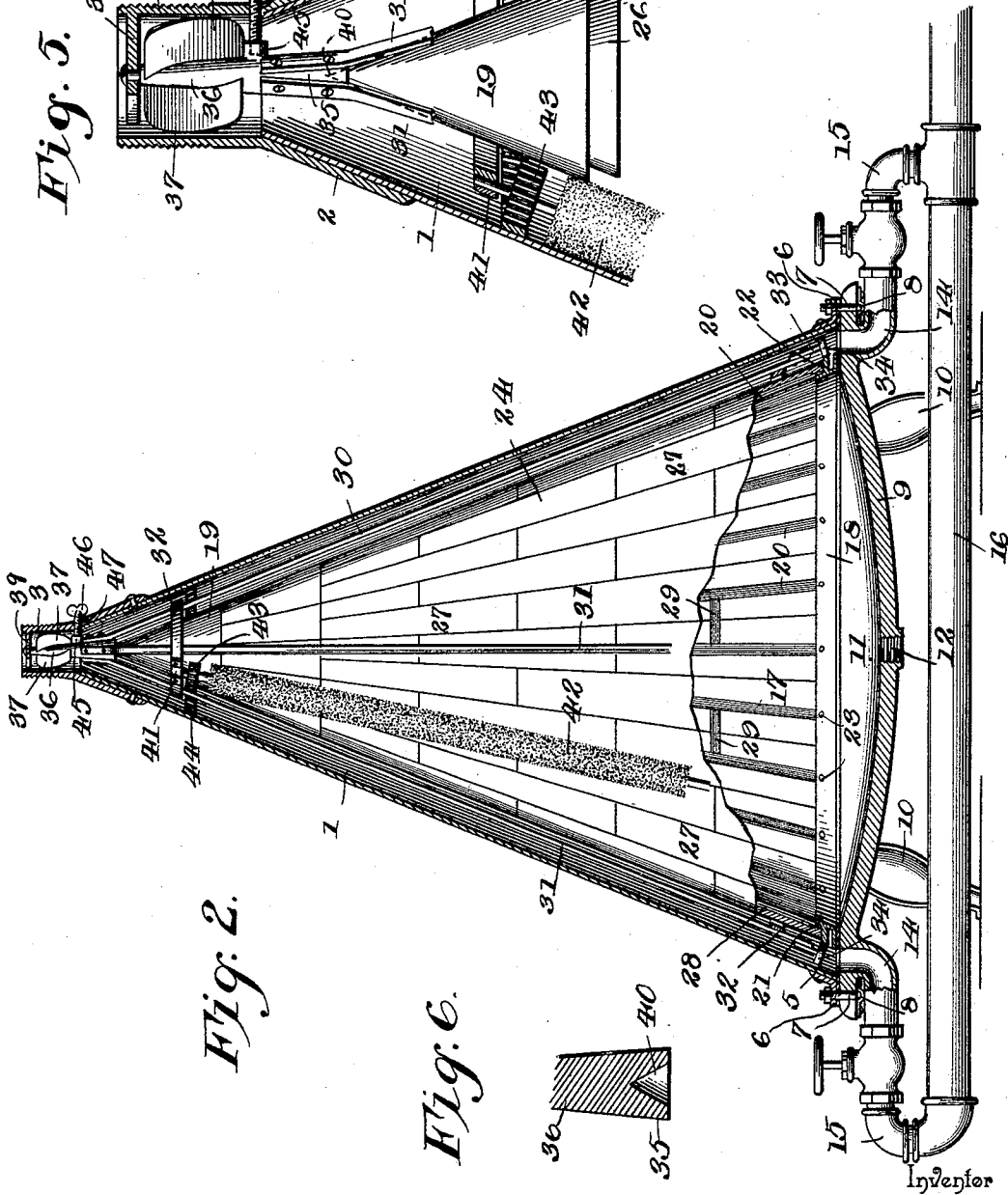
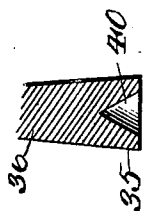

Fig. 6.



Inventor

Joseph H. Pierce,

By his Attorneys,

Chas. A. Ford

Witnesses

Chas. A. Ford

S. P. Thompson

(No Model.)

3 Sheets—Sheet 3.

J. H. PIERCE.
WATER FILTER.

No. 583,236.

Patented May 25, 1897.

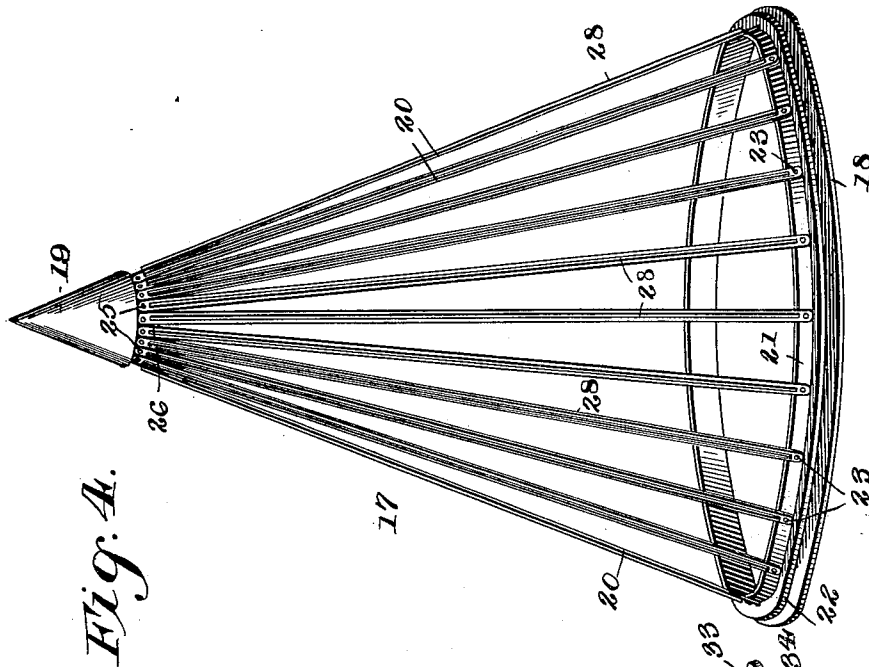

Fig. A.

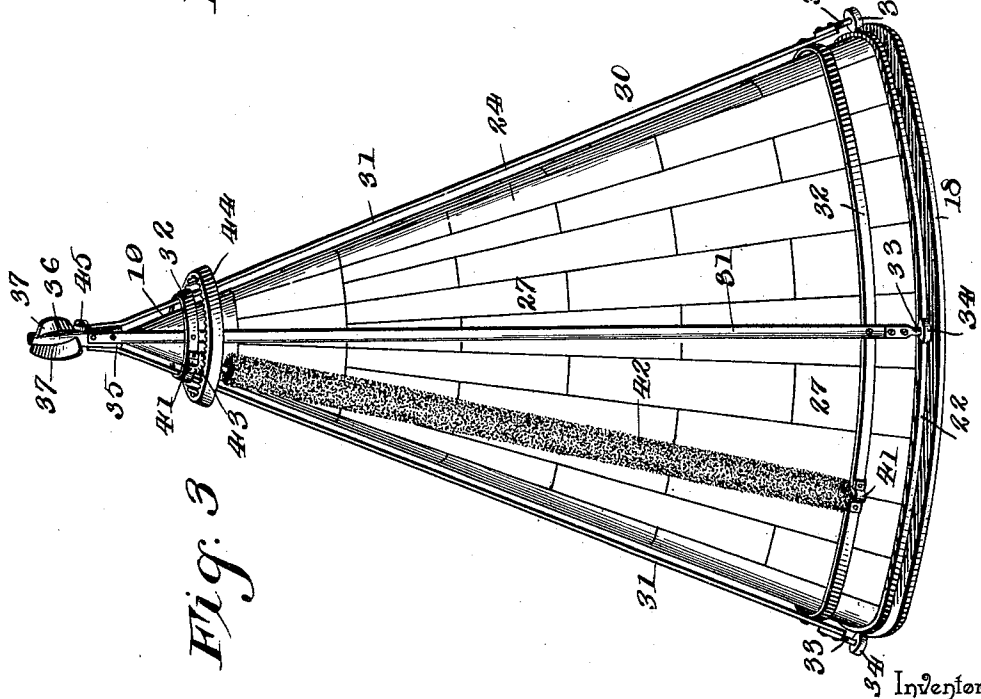

Fig. 3

Inventor

Joseph H. Pierce,

Witnesses

Chas. A. Ford.
S. P. H. [Signature]

By his Attorneys,

C. Snow & Co.

UNITED STATES PATENT OFFICE.

JOSEPH H. PIERCE, OF DENVER, COLORADO.

WATER-FILTER.

SPECIFICATION forming part of Letters Patent No. 583,236, dated May 25, 1897.

Application filed April 27, 1896. Serial No. 589,273. (No model.)

To all whom it may concern:

Be it known that I, JOSEPH H. PIERCE, a citizen of the United States, residing at Denver, in the county of Arapahoe and State of Colorado, have invented a new and useful Water-Filter, of which the following is a specification.

This invention relates to filters; and it has for its object to provide a pressure-filter adapted to be used in connection with a line of piping carrying water under pressure.

To this end the main and primary object of the invention is to construct a pressure-filter in a simple and efficient manner and to provide a large filtering area, whereby the filter shall be especially available for use for filtering on a large scale, as is demanded in laundries, bottling-works, hotels, and the like, and the invention also contemplates novel and efficient means for quickly and readily cleaning the entire filter from sedimentary matter.

With these and other objects in view, which will readily appear as the nature of the invention is better understood, the same consists in the novel construction, combination, and arrangement of parts hereinafter more fully described, illustrated, and claimed.

In the drawings, Figure 1 is a perspective view of a filter constructed in accordance with this invention. Fig. 2 is a central vertical sectional view thereof. Fig. 3 is a perspective view of the stationary conical filter-stone and the skeleton revolving brush-frame encircling the same. Fig. 4 is a perspective view of the skeleton stone-supporting frame. Fig. 5 is an enlarged detail sectional view at the upper end of the filter, illustrating more clearly the construction of the turbine. Fig. 6 is a detail sectional view of the lower end of the turbine-hub.

Referring to the accompanying drawings, 1 designates a conical metallic filter-casing constructed in a suitable size according to the required capacity of the filter, and the said casing 1 has fitted to the upper contracted end thereof an apex cap 2, provided with an exteriorly-threaded upwardly-extending inlet-neck 3, to which is fitted the inlet-valve 4, which controls the inlet of water to be filtered into the top of the casing and regulates the

pressure thereof. The conical casing 1 has fitted to its flared lower edge a flanged attaching-ring 5, provided in its outer edge at intervals with a series of bolt-notches 6, which removably receive the free ends of the hinged fastening-bolts 7, hinged at their lower ends, as at 8, to the under side of the bottom cap 9, near the edge thereof, and providing simple and efficient means for detachably clamping the conical casing onto its bottom cap, but it will of course be understood that any other suitable fastening means may be employed for effecting the same result.

The bottom cap 9 of the filter-casing preferably has fitted to the under side thereof a series of supporting-legs 10 for properly supporting the filter in position at any convenient point, and the said bottom cap 9 is downwardly dished to form a basin 11 for filtered water, which has an outlet through the outlet-opening 12, formed centrally in the cap 9 and in which is fitted one end of the filtered-water pipe 13, which leads to any desired point of use. In addition to the central outlet-opening 12 the bottom cap 9 of the casing is provided at diametrically opposite points outside of the plane of the basin 11 with the depending drain-nipples 14, to which are fitted the valved branch pipes 15, both of which are connected to the common waste-pipe 16, which is brought into use when the filter is cleaned by flushing, in a manner to be more particularly referred to, and the portion of the waste-pipe 16 lying between the opposite valved branch pipes 15 is preferably conveniently disposed out of the way below the bottom cap 9.

The conical filter-casing 1 has arranged therein a stationary upright conical stone-supporting frame 17. The stone-supporting frame 17 essentially consists of a flanged base-ring 18, an upper bearing-cone 19, and a series of convergently-arranged mullions 20. The base-ring 18 is securely bolted in a watertight joint on the upper side of the bottom cap 9 at a point outside of the circle of the basin 11 and at a distance from the casing 1, so as to leave a space between said casing and the frame 17, with which space communicate the drain-nipples 14, as clearly illustrated in Fig. 2 of the drawings. The flange

21 of the ring 18 converges upwardly and is provided at a point intermediate of its upper and lower edges with a horizontal circular track-flange 22, and above the track 22 the flange 21 has attached thereto, by means of bolts or rivets 23, the lower ends of the circular group of convergently-arranged mullions 20. The mullions 20 are arranged sufficiently close together to provide for the support of the hollow conical filter-stone 24 and are suitably fastened at their upper ends, as at 25, to the shouldered lower end 26 of the bearing-cone 19, which completes the upper end of the frame 17.

The hollow conical filter-stone 24 is preferably sectional and is composed of a number of filter bricks or sections 27, cemented together and on the mullions 20 to complete a conical filtering medium or stone entirely covering the skeleton part of the frame 17. In order that the bricks or sections 27 of the sectional stone 24 may be securely held in place, the mullions 20 of the frame 17 are preferably provided on their outer sides with longitudinal ribs 28, which engage in grooves in the inner sides of the stone-sections 27, and said stone-sections being cemented at their meeting edges and also on the ribbed mullions will necessarily be firmly connected together to complete the hollow conical stone 24, through which the water is filtered under pressure into the space confined within the stone, from which the filtered water is drawn through the filtered-water pipe 13 at the bottom of the casing, as will be readily understood. The bricks or sections 27 of the conical stone 24 are preferably arranged so as to break joints, whereby said joints will not interfere materially with the filtering action at any particular point on the stone, and in order to more firmly support the filter bricks or sections 27 short brace-strips 29 may connect the mullions 20, as illustrated in Fig. 2, at the points where the ends of the said bricks or sections 27 meet.

Arranged to work in the space between the exterior of the conical filter-stone 24 and the casing 1 is a revolving skeleton brush-frame 30, essentially consisting of a convergent series of longitudinally-arranged frame-strips 31, connected near their upper and lower ends by the frame-bands 32. The lower extremities of the longitudinal strips 31 of the frame 30 have fitted thereto the short spindles 33, on which are journaled the traveler-wheels 34, which ride or travel on the track-flange 22 of the flange 21, and which track-flange also forms a base or rest for the lower tier of the filter bricks or sections 27, as clearly illustrated in the drawings. The travelers 34 provide a wheeled support for the lower end of the frame 30, and the upper adjacent ends of the strips 31 forming said frame are fitted to the lower flared end 35 of the revolving turbine-hub 36, provided at a point intermediate of its ends with a pair or more of spirally-arranged blades 37, forming a tur-

bine arranged to revolve within the inlet-neck 3 at the top of the casing 1. The upper end of the turbine-hub 36 is suitably mounted to turn centrally in the transverse bearing-web 39, arranged transversely within the neck 3, and in its lower end the hub 36 is provided with a conical bearing-socket 40, which receives the point or apex of the bearing-cone 19 at the upper end of the stone-supporting frame 17, said cone 19 thereby providing a pivotal bearing-support for the upper end of the revolving skeleton frame 30.

The upper and lower frame-bands 32 of the skeleton frame 30 are provided with the aligned bearing-boxes 41, in which are journaled, respectively, the opposite spindle extremities of the revolving cleaning-brush 42, carried by the frame 30 and arranged to work in the space between the casing 1 and the stone 24. The brush 42 also works directly against the exterior surface of the stone 24, and has fitted on its upper spindle extremity a pinion 43, which meshes with the teeth of an internally-toothed cog-ring 44, secured in a stationary position within the upper contracted end of the casing 1, so as to provide means, in connection with the pinion 43, for the rotation of the brush 42 when the frame 30 revolves and in a reverse direction to the motion of said frame.

In order to secure the frame 30 stationary, the turbine-hub 36 is provided below its blades 37 with an offstanding recessed lug 45, designed to removably receive the inner tip end of the set-screw 46, mounted in a threaded opening 47 in one side of the cap 2, to provide simple and convenient means for locking the turbine and the frame 30 against rotation and also for releasing the same to permit rotation under the influence of the incoming water operating on said turbine.

When the filter is in use, the revolving brush-frame is held stationary in the manner described, and the valves in the branch drain-pipes 15 closed; but when it is desired to clean the filter-stone the said valves of the pipes 15 are opened and the screw 46 unscrewed, so as to release the turbine. The incoming water will then rotate the turbine, which in turn will communicate motion to the frame 30 and cause the brush 42 to be swung around the stone 24, and at the same time revolve so as to thoroughly brush or scrape dirt or other sedimentary deposits off from the stone, and by reason of the conical shape of the stone it will be noted that with the pipes 15 open the water has a natural tendency to wash said sedimentary matter off of the stone, and with the aid of the brush 42 the said filter can be thoroughly cleaned by flushing. By making the combined capacity of the drains 14 greater than the capacity of the inlet the water will be entirely unimpeded and will flush out the filter naturally even without the aid of the brush.

Changes in the form, proportion, and the minor details of construction may be resorted

to without departing from the principle or sacrificing any of the advantages of this invention.

Having thus described the invention, what is claimed, and desired to be secured by Letters Patent, is—

1. In a filter, a conical casing provided at the top or apex with an inlet-neck and with a downwardly-dished bottom cap having a central filtered-water outlet and near its edges with diametrically opposite depending drain-nipples, a common waste-pipe, valved branch pipes respectively connected with said drain-nipples and to said waste-pipe, and a hollow conical filter-stone supported within the casing on the bottom cap between the dish of said cap and said drain-nipples, substantially as set forth.

2. In a filter, a conical casing having a water-inlet at its apex and a bottom cap provided with a central filtered-water outlet, a stationary upright hollow conical filter-stone supported on said bottom cap within the casing, a revolving brush-frame arranged between the casing and the stone, a revolving brush journaled on the brush-frame, and means for revolving the brush by the rotation of the brush-frame, substantially as set forth.

3. In a filter, the conical casing, a bottom cap covering the lower end of said casing, a stationary skeleton upright conical stone-supporting frame arranged within the casing on said bottom cap, and a hollow conical sectional filter-stone built exteriorly on said supporting-frame, substantially as set forth.

4. In a filter, a casing, a stationary skeleton stone-supporting frame arranged within the casing and of a smaller size than the same, and a hollow conical sectional filter-stone built exteriorly on said supporting-frame, substantially as set forth.

5. In a filter, a conical casing having an inlet at its apex and a bottom cap provided with a central water-outlet, a stationary upright conical stone-supporting frame arranged within the casing and comprising a flanged base-ring, an upper cone, and a circular series of convergently-arranged mullions secured at their lower ends to the flange of the base-ring and at their upper ends to said upper cone, said mullions being provided on their outer sides with longitudinal ribs, the base-ring of said frame being secured on said bottom cap, and a hollow conical filter-stone built exteriorly on the mullions of said stone-supporting frame, substantially as set forth.

6. In a filter, a conical casing having an inlet at its apex and a bottom cap provided with a central filtered-water outlet, and with valved drains near its edge, a hollow conical filter-stone supported on the bottom cap within the casing, a skeleton revolving brush-frame arranged between the casing and the stone and carrying at its upper end a turbine arranged within the inlet of the casing, a revolving brush journaled on the brush-frame, and means for revolving said brush by the rotation of the brush-frame, substantially as set forth.

7. In a filter, the casing, a filter-stone arranged in the casing, a revolving brush-frame arranged between the casing and the stone and carrying a turbine arranged within the inlet of the casing, a revolving brush journaled on the brush-frame, and means for revolving said brush by the rotation of the brush-frame, substantially as set forth.

8. In a filter, the casing having an inlet-neck at its apex and a bottom cap provided with a central filtered-water outlet, and with valved drains near its edge, an upright conical stone-supporting frame arranged within the casing and provided at its top with a bearing-cone and at the bottom with an exterior circular track-flange, a hollow conical filter-stone arranged on said stone-supporting frame, a vertically-arranged turbine mounted within said inlet-neck, the hub of said turbine being provided in its lower end with a conical bearing-socket receiving the apex of said bearing-cone and at an intermediate point with an offstanding lug, a skeleton revolving brush-frame essentially consisting of a series of connected converging strips secured at their upper ends to the hub of the turbine and carrying at their lower extremities traveler-wheels riding on said track-flange, an internally-toothed stationary cog-ring secured within the upper contracted end of the casing, a revolving cleaning-brush journaled in a fixed position on the brush-frame and carrying at one end a pinion meshing with the teeth of said cog-ring, and a set-screw mounted in one side of said inlet-neck and adapted to engage the lug of the turbine-hub, substantially as set forth.

In testimony that I claim the foregoing as my own I have hereto affixed my signature in the presence of two witnesses.

JOSEPH H. PIERCE.

Witnesses:

JOHN T. GATES,
E. B. WEARE.