



- (51) **International Patent Classification:**
G06F 3/033 (2006.01) G06F 3/041 (2006.01)
- (21) **International Application Number:**
PCT/FI2009/050253
- (22) **International Filing Date:**
3 April 2009 (03.04.2009)
- (25) **Filing Language:** English
- (26) **Publication Language:** English
- (30) **Priority Data:**
12/082,888 14 April 2008 (14.04.2008) US
- (71) **Applicant (for all designated States except US):** NOKIA CORPORATION [FI/FI]; Keilalahdentie 4, FI-02150 Espoo (FI).
- (72) **Inventor; and**
- (75) **Inventor/Applicant (for US only):** NURMI, Mikko [FI/FI]; Vellamonkatu 14 A 24, FI-33500 Tampere (FI).
- (74) **Agent:** NOKIA CORPORATION; IPR Department, Virpi Tognetty, Keilalahdentie 4, FI-02150 Espoo (FI).
- (81) **Designated States (unless otherwise indicated, for every kind of national protection available):** AE, AG, AL, AM, AO, AT, AU, AZ, BA, BB, BG, BH, BR, BW, BY, BZ,

CA, CH, CN, CO, CR, CU, CZ, DE, DK, DM, DO, DZ, EC, EE, EG, ES, FI, GB, GD, GE, GH, GM, GT, HN, HR, HU, ID, IL, IN, IS, JP, KE, KG, KM, KN, KP, KR, KZ, LA, LC, LK, LR, LS, LT, LU, LY, MA, MD, ME, MG, MK, MN, MW, MX, MY, MZ, NA, NG, NI, NO, NZ, OM, PG, PH, PL, PT, RO, RS, RU, SC, SD, SE, SG, SK, SL, SM, ST, SV, SY, TJ, TM, TN, TR, TT, TZ, UA, UG, US, UZ, VC, VN, ZA, ZM, ZW.

(84) **Designated States (unless otherwise indicated, for every kind of regional protection available):** ARIPO (BW, GH, GM, KE, LS, MW, MZ, NA, SD, SL, SZ, TZ, UG, ZM, ZW), Eurasian (AM, AZ, BY, KG, KZ, MD, RU, TJ, TM), European (AT, BE, BG, CH, CY, CZ, DE, DK, EE, ES, FI, FR, GB, GR, HR, HU, IE, IS, IT, LT, LU, LV, MC, MK, MT, NL, NO, PL, PT, RO, SE, SI, SK, TR), OAPI (BF, BJ, CF, CG, CI, CM, GA, GN, GQ, GW, ML, MR, NE, SN, TD, TG).

Published:
— with international search report (Art. 21(3))
— before the expiration of the time limit for amending the claims and to be republished in the event of receipt of amendments (Rule 48.2(h))

(54) **Title:** A USER INTERFACE

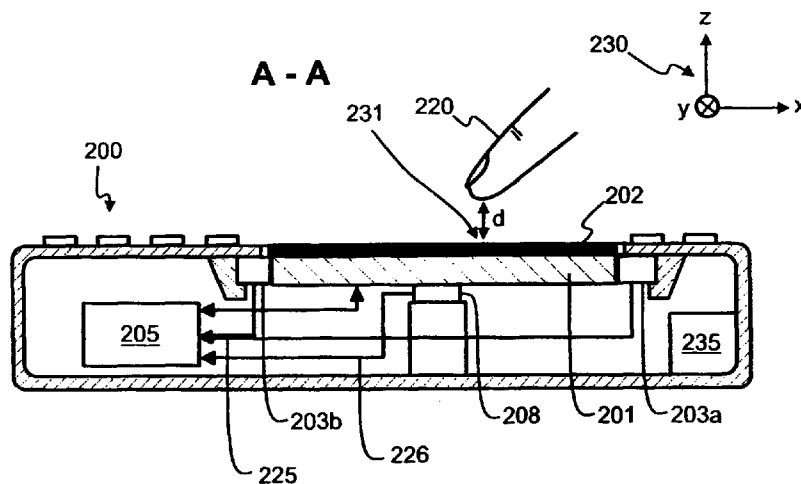
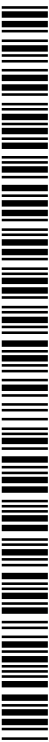

Fig. 2b

(57) **Abstract:** The invention relates to a user interface for controlling an electronic device. The user interface comprises a sensor element (201) that has a sensor surface (202) and is arranged to produce a location indicator that indicates a location of a spot (231) of the sensor surface that is closest to an external object (220). The user interface comprises force sensor equipment (203a, 203b) that is arranged to produce a force indicator that indicates temporal changes of force components directed to the sensor surface in parallel with the sensor surface. A processor unit (205) is arranged to control the electronic device on the basis of the location indicator and the force indicator. A user of the electronic device is enabled to control the electronic device by using different levels and directions of force and/or torque directed to the sensor surface.



WO 2009/127779 A1

A user interface

Field of the invention

The invention relates to a user interface for controlling an electronic device. The invention further relates to a method and a computer program for controlling an electronic device.

5 The invention further relates to an electronic device and to an interface module that can be used as a building block of an electronic device.

Background

Electronic devices such as mobile communication terminals and palmtop computers are typically equipped with digital devices capable of supporting various services and applica-
10 tion functions. As a consequence, designing user interfaces for electronic devices of the kind mentioned above presents unique challenges in view of limited size, a limited number of controls that can be accommodated on such devices, and a need for quick, simple, and intuitive device operation. Especially in conjunction with mobile devices, the challenge re-
15 lated to a user interface is exacerbated because such devices are designed to be small, lightweight and easily portable. Consequently, mobile devices typically have limited display screens, keypads, keyboards and/or other input and output devices. Due to the size of the input and output devices, it may be difficult for users to enter, retrieve and view information using mobile devices. Users may have difficulty in accessing desired information, a
20 desired service, and/or a desired application function due to variety of information that may be contained in or accessed with the mobile device, as well as due to a growing number of services and applications functions such devices are capable of supporting. Due to a great number of services and application functions a user interface of an electronic device typically includes a hierarchical menu structure.

A typical user interface of an electronic device according to the prior art includes a
25 hierarchical menu structure in which one or more menu layers are being directly accessible at a time. The user interface can comprise a touch sensitive display screen such that a user of the electronic device is enabled to accomplish control actions by touching icons, texts, or other symbols displayed on the touch sensitive display screen. Due to the limited size of the touch sensitive display screen all details of the menu structure cannot usually be dis-
30 played simultaneously. Therefore, the user has usually to perform many successive control actions in order to get to a desired menu item that can be e.g. a desired application function to be performed. Each control action may include pressing a relevant spot of the touch sensitive display screen and, after getting response to the pressing, releasing the above-
35 mentioned spot of the touch sensitive display screen from pressure. The repetitive pressing and release actions make the use of the user interface physically tiring.

Summary

In accordance with a first aspect of the invention a novel user interface is provided. The user interface comprises:

- 5 - a sensor element having a sensor surface and being arranged to produce a location indicator that is adapted to indicate a location of a spot of the sensor surface that is closest to an external object,
- force sensor equipment connected to the sensor element and arranged to produce a force indicator that is adapted to indicate a temporal change of a first force component directed to the sensor surface and a temporal change of a second force component directed to the sensor surface, the first force component and the second force component being parallel with the sensor surface, and
- 10 - a processor unit capable of controlling an electronic device on the basis of the location indicator and the force indicator.

15 A user of the electronic device is enabled to control the electronic device by using different levels and directions of force and/or torque directed to the sensor surface. Therefore, the electronic device can be controlled with a smaller number of repetitive pressing and release actions.

In accordance with a second aspect of the invention a novel method that can be used for controlling an electronic device is provided. The method comprises:

- 20 - producing a location indicator that indicates a location of a spot of a sensor surface that is closest to an external object,
- producing a force indicator that indicates a temporal change of a first force component directed to the sensor surface and a temporal change of a second force component directed to the sensor surface, the first force component and the second force component being parallel with the sensor surface, and
- 25 - controlling an electronic device on the basis of the location indicator and the force indicator.

In accordance with a third aspect of the invention a novel electronic device is provided. The electronic device comprises:

- 30 - a sensor element having a sensor surface and being arranged to produce a location indicator that is adapted to indicate a location of a spot of the sensor surface that is closest to an external object,
- force sensor equipment connected to the sensor element and arranged to produce a force indicator that is adapted to indicate a temporal change of a first force component directed to the sensor surface and a temporal change of a second force component directed to the sensor surface, the first force component and the second force component being parallel with the sensor surface, and
- 35 - a processor unit capable of controlling an electronic device on the basis of the location indicator and the force indicator.

- a processor unit arranged to control the electronic device on the basis of the location indicator and the force indicator.

The electronic device can be, for example, a mobile communication terminal, a palmtop computer, a portable play station, or a combination of them.

5 In accordance with a fourth aspect of the invention a novel computer program is provided. The computer program comprises computer executable instructions for making a processor unit to control an electronic device on the basis of:

- a location indicator that is adapted to indicate a location of a spot of a sensor surface that is closest to an external object, and
- 10 - a force indicator that is adapted to indicate a temporal change of a first force component directed to the sensor surface and a temporal change of a second force component directed to the sensor surface, the first force component and the second force component being parallel with the sensor surface.

15 A computer readable medium can be encoded with the above-mentioned computer executable instructions.

In accordance with a fifth aspect of the invention a novel interface module is provided. The interface module comprises:

- a sensor element having a sensor surface and being arranged to produce a location indicator that is adapted to indicate a location of a spot of the sensor surface that is closest to an external object,
- 20 - force sensor equipment connected to the sensor element and arranged to produce a force indicator that is adapted to indicate a temporal change of a first force component directed to the sensor surface and a temporal change of a second force component directed to the sensor surface, the first force component and the second force component being parallel with the sensor surface, and
- 25 - a processor unit capable of controlling an electronic device connected to the interface module on the basis of the location indicator and the force indicator.

A number of embodiments of the invention are described in accompanied dependent claims.

30 Various exemplifying embodiments of the invention both as to constructions and to methods of operation, together with additional objects and advantages thereof, will be best understood from the following description of specific embodiments when read in connection with the accompanying drawings.

35 The exemplifying embodiments of the invention presented in this document are not to be interpreted to pose limitations to the applicability of the appended claims. The verb "to comprise" is used in this document as an open limitation that does not exclude the existence of also unrecited features. The features recited in depending claims are mutually freely combinable unless otherwise explicitly stated.

Brief description of the figures

The embodiments of the invention that are presented in the sense of examples and their advantages are explained in greater detail below with reference to the accompanying drawings, in which:

- 5 figures 1a - 1h illustrate operational principles of user interfaces according to embodiments of the invention,
figures 2a and 2b show an electronic device comprising a user interface according to an embodiment of the invention,
figures 3a and 3b show an electronic device according to an embodiment of the invention,
10 figure 4 shows an interface module according to an embodiment of the invention, and
figure 5 is a flow chart of a method according to an embodiment of the invention.

Description of the embodiments

A user interface according to an embodiment of the invention comprises: (i) a sensor element having a sensor surface and being arranged to produce a location indicator that is adapted to indicate a location of a spot of the sensor surface that is closest to an external object, (ii) force sensor equipment connected to the sensor element and arranged to produce a force indicator that is adapted to indicate a temporal change of a first force component directed to the sensor surface and a temporal change of a second force component directed to the sensor surface, the first force component and the second force component being parallel with the sensor surface, and (iii) a processor unit capable of controlling an electronic device on the basis of the location indicator and the force indicator.

Figures 1a - 1h illustrate operational principles of user interfaces according to embodiments of the invention. The user interfaces comprise a sensor element 101 that has a sensor surface 102. For the sake of clarity, figures 1a - 1h are simplified. For example, a processor unit for controlling an electronic device on the basis of the location indicator and the force indicator is not shown. A coordinate system 130 is shown for presentational purposes.

Figure 1a shows an exemplifying situation in which an external object 120 directs to the sensor surface 102 force \mathbf{F} that has an x-component, a y-component, and a (minus) z-component. The x- and y-components of the force \mathbf{F} are due to friction between the sensor surface and the external object. The external object can direct the force to the sensor surface when the external object is static with respect to the sensor surface and also when a contact point between the external object and the sensor surface is moving along the sensor surface. The external object can be a finger of a user of the user interface or the external object can be e.g. a stylus. In the exemplifying case shown in figure 1a, the force sensor equipment comprises a force detector 103 that is arranged to detect a first force component

that is an x-directional force component F_x and to detect a second force component that is a y-directional force component F_y . The x-directional force component F_x is a counterforce of the x-component of the force \mathbf{F} and the y-directional force component F_y is a counterforce of the y-component of the force \mathbf{F} . An electronic device that is connected to the user interface can be controlled, for example, on the basis of location and/or movement of the external object 120 touching the sensor surface 102 and also on the basis of temporal changes of direction and/or strength of the resultant of F_x and F_y .

Figure 1b shows an exemplifying situation in which a first external object 120 directs to the sensor surface 102 first force \mathbf{F}_1 that has an x-component and a y-component and a second external object 121 directs to the sensor surface second force \mathbf{F}_2 that has an x-component and a y-component. The common effect of the first and the second forces \mathbf{F}_1 and \mathbf{F}_2 causes torque \mathbf{T} directed to the sensor surface 102. In the exemplifying case shown in figure 1b, the force sensor equipment comprises a force detector 103a connected to a first point of the sensor element 101 and a force detector 103b connected to a second point of the sensor element. The force detector 103a is arranged to detect a first force component that is a y-directional force component F_{y1} . The force detector 103b is arranged to detect a second force component that is another y-directional force component F_{y2} . The force components F_{y1} and F_{y2} and a distance D_x shown in figure 1b indicate at least part of the torque \mathbf{T} directed to the sensor surface. An electronic device that is connected to the user interface can be controlled, for example, on the basis of locations and/or movements of the external objects 120 and 121 touching the sensor surface 102 and also on the basis of temporal changes of the indicated torque.

In the example case illustrated in figure 1a, the first and the second force components directed to the sensor surface 102 are detected substantially at a same point of the sensor element 101 but detection directions of the first and the second force components are mutually different. In the example case illustrated in figure 1a, the detection directions of the first force component and the second force component are substantially perpendicular with respect to each other, i.e. the x-direction and the y-direction. It is, however, sufficient that the detection directions of the first force component and the second force component are mutually intersecting, i.e. they do not necessarily have to be perpendicular to each other. In the example case illustrated in figure 1b, both the first force component and the second force component are detected in the y-direction but the first force component and the second force component are detected at different points of the sensor element.

Figure 1c illustrates an example case in which the force sensor equipment comprises force detectors 103a-103d that are arranged to detect force components F_{y1} - F_{y4} , respectively, and force detectors 103e-103h that are arranged to detect force components F_{x1} - F_{x4} , respectively. The x-component of resultant force directed to the sensor surface 102 is $F_{x3} + F_{x4} - F_{x1} - F_{x2}$, the y-component of the resultant force is $F_{y3} + F_{y4} - F_{y1} - F_{y2}$,

and torque directed to the sensor surface with respect to the geometrical middle point of the sensor surface is $(F_{y1} - F_{y2} + F_{y4} - F_{y3}) \times D_x/2 + (F_{x1} - F_{x2} + F_{x4} - F_{x3}) \times D_y/2$. The force sensor equipment can be provided also with a force detector that is arranged to detect the z-component of the resultant force in which case the resultant force can be detected in all three dimensions. An electronic device that is connected to the user interface can be controlled, for example, on the basis of location and/or movement of an external object touching the sensor surface, on the basis of temporal changes of the strength and/or the direction of the resultant force, and on the basis of temporal changes of the torque.

Figures 1a, 1b, and 1c present example cases in which the force sensor equipment comprises one or more force detectors that are connected to edges of the sensor element 101. Alternative realizations for the force sensor equipment are illustrated in figures 1d-1h. Figure 1e shows a section taken through A-A of figure 1d, figure 1g shows a section taken through A-A of figure 1f, and figure 1h shows a section taken through B-B of figure 1g. Figures 1d and 1e illustrate an example case in which the force sensor equipment comprises a torsional sensor 103 connected to the sensor element 101 and arranged to detect torque T caused by common effect of force components directed to the sensor surface 102. Figures 1f, 1g, and 1h illustrate an example case in which the force sensor equipment comprises a ring-sensor 103 arranged to detect first and second components F_x and F_y of force F directed to the sensor surface 102. The ring-sensor 103 is located around a rod 104 that is attached to the sensor element 101. The rod is supported with a flexible joint 106 to surrounding structures.

Figure 2a shows an electronic device 200 comprising a user interface according to an embodiment of the invention. Figure 2b shows the A-A section view of the electronic device. A coordinate system 230 is shown for presentational purposes. The user interface of the electronic device comprises a sensor element 201 that has a sensor surface 202. The sensor element is arranged to produce a location indicator that is adapted to indicate a location of a spot 231 of the sensor surface 202 that is closest to an external object 220. The location indicator is an output signal of the sensor element 201. The location indicator can express, for example, x- and y-coordinates of the spot 231. In the exemplifying situation shown in figures 2a and 2b the external object is a finger 220 of a user of the electronic device 200. It is also possible to use a sensor element that is capable of producing a location indicator adapted to indicate locations of two or more spots of the sensor surface which are simultaneously touched by (or sufficiently near to) two or more external objects. The user interface comprises force sensor equipment arranged to produce a force indicator 225 that is adapted to indicate a temporal change of a first force component directed to the sensor surface and a temporal change of a second force component directed to the sensor surface. The first force component can be e.g. an x-component of force directed to the sensor surface 202 and the second force component can be e.g. a y-component of the force directed

to the sensor surface. The force sensor equipment comprises force detectors 203a and 203b that are arranged to detect forces in the x-direction. The force sensor equipment comprises also force detectors (not shown) that are arranged to detect forces in the y-direction. The force detectors can be, for example, according to what is depicted in figure 1c. Output signals of the force detectors constitute the force indicator 225. The user interface comprises a processor unit 205 that is arranged to control the electronic device on the basis of the location indicator and the force indicator. The user interface can comprise a vibration generator 235 responsive to the force indicator and/or to the location indicator. Mechanical vibration generated with the vibration generator can be used e.g. for indicating that the electronic device has received a control action from the user.

In the electronic device shown in figures 2a and 2b, the sensor surface 202 is also a display screen with the aid of which visual information can be shown. It is also possible that a display screen is only a part of the sensor surface 202 or the sensor surface 202 is only a part of a display screen. The user interface of the electronic device can comprise also a keyboard 210 and/or other means for exchanging information between the electronic device and the user.

In a user interface according to an embodiment of the invention, the sensor surface 202 is a touch sensitive sensor surface that is arranged to produce the location indicator as a response to a situation in which the external object 220 touches the sensor surface.

In a user interface according to an embodiment of the invention, the sensor surface 202 is a capacitive sensor surface that is arranged to produce the location indicator as a response to a situation in which the distance d between the sensor surface and the external object 220 is less than a pre-determined limit value.

In a user interface according to an embodiment of the invention, the sensor surface 202 is a combined touch sensitive and capacitive sensor surface. In other words, the sensor element 201 is capable of detecting a situation in which the external object does not touch the sensor surface but the distance d between the sensor surface and the external object is less than the pre-determined limit value and the sensor element is capable of distinguishing the above-described situation from a situation in which the external object touches the sensor surface.

In a user interface according to an embodiment of the invention, the processor unit 205 is capable of controlling the electronic device 200 to execute a pre-determined function as a response to a situation in which a pre-determined change is detected in at least one of the following: strength of the x-component of the force directed to the sensor surface and strength of the y-component of the force.

In a user interface according to an embodiment of the invention, the processor unit 205 is capable of controlling the electronic device to execute a pre-determined function as a response to a situation in which a pre-determined change is detected in direction of the

resultant of the x-and y-components of the force directed to the sensor surface; e.g. when the resultant of the x-and y-components of the force is being rotated. It should be noted that the direction of the resultant can change irrespective whether or not strength (absolute value) of the resultant is changing.

5 In a user interface according to an embodiment of the invention, the processor unit 205 is capable of controlling the electronic device to execute a pre-determined function as a response to a situation in which a pre-determined change is detected in torque caused by combined effect of components of the force directed to the sensor surface.

10 In a user interface according to an embodiment of the invention, the force sensor equipment comprises a force detector 208 arranged to produce another force indicator 226 adapted to indicate a temporal change of a third force component directed to the sensor surface. The third force component is preferably the z-component of the force directed to the sensor surface. The processor unit is capable of controlling the electronic device on the basis of the location indicator, the force indicator (the x and y -directions), and the other
15 force indicator (the z-direction). It is also possible to use a sensor element that is capable of producing a location indicator adapted to indicate locations of two or more spots of the sensor surface which are simultaneously touched by two or more external objects. In this case, the force indicator and the other force indicator indicate preferably x-, y- and z-components of a resultant of forces directed to the said two or more spots of the sensor sur-
20 face.

In a user interface according to an embodiment of the invention, the processor unit 205 is capable of controlling the electronic device according to strength and direction of the resultant of the x-and y-components of the force directed to the sensor surface. Therefore, the sensor surface or a pre-determined area of the sensor surface can be used as a joy-
25 stick. The force sensor equipment can be arranged to indicate also the z-component of the force directed to the sensor surface. In this case, the sensor surface or the pre-determined area of the sensor surface can be used as a three dimensional joystick (3D-joystick) for controlling the electronic device according to strength and direction of the resultant of the x-, y, and z-components of the force directed to the sensor surface.

30 In a user interface according to an embodiment of the invention, the sensor surface 202 is a capacitive sensor surface and the processor unit 205 is arranged to highlight a symbol displayed on the sensor surface as a response to a situation in which the distance d between the external object 220 and the symbol is less than a pre-determined limit value. The symbol can be, for example, an icon 211, a piece of text 212, or some other kind of
35 piece of visual information shown on the sensor surface.

In a user interface according to an embodiment of the invention, the processor unit 205 is arranged to select the symbol 211 and to modify visual information displayed on the sensor surface 202 around the symbol as a response to a situation in which the external ob-

ject 220 is touching the sensor surface in a location in which the symbol 211 is being displayed.

In a user interface according to an embodiment of the invention, the processor unit 205 is arranged to change the symbol 211 displayed on the sensor surface from a non-selected state to a selected-to-move state and to move a position of the symbol on the sensor surface 202 as a response to a situation in which the external object 220 is touching the sensor surface in a location in which the symbol is being displayed and the external object directs to the sensor surface force that has a component parallel with the sensor surface and strength of the said component exceeds a predetermined limit. The symbol is moved towards direction of the above-mentioned component of the force. After moving, the symbol can be returned back to the non-selected state as a response to e.g. a situation in which the sensor surface is no more touched.

In a user interface according to an embodiment of the invention, the processor unit 205 is capable of controlling the electronic device to change colors displayed on a display screen according (a) temporal change(s) in at least one of the following: a) direction of force directed to the sensor surface, b) torque caused by combined effect of components of the force directed to the sensor surface, and c) strength of the force directed to the sensor surface.

In a user interface according to an embodiment of the invention, the processor unit 205 is capable of controlling the electronic device to scroll items displayed on the display screen according to (a) temporal change(s) in at least one of the following: a) direction of force directed to the sensor surface, b) torque caused by combined effect of components of the force directed to the sensor surface, and c) strength of the force directed to the sensor surface. For example, scrolling direction (forward/backward) can depend on the direction of the force and scrolling speed can depend on the strength of the force.

In a user interface according to an embodiment of the invention, the processor unit 205 is capable of controlling the electronic device to zoom items displayed on the display screen according to (a) temporal change(s) in at least one of the following: a) direction of force directed to the sensor surface, b) torque caused by combined effect of components of the force directed to the sensor surface, and c) strength of the force directed to the sensor surface. For example, zooming direction (zoom in/zoom out) can depend on the direction of the force and zooming speed can depend on the strength of the force.

In a user interface according to an embodiment of the invention, the processor unit 205 is capable of controlling the electronic device to rotate items displayed on the display screen according to (a) temporal change(s) in at least one of the following: a) direction of force directed to the sensor surface, b) torque caused by combined effect of components of the force directed to the sensor surface, and c) strength of the force directed to the sensor

surface. For example, direction of rotation (clockwise/counterclockwise) can depend on the direction of the force and speed of the rotation can depend on the strength of the force.

In a user interface according to an embodiment of the invention, the processor unit 205 is capable of controlling the electronic device to select an action directed to an item displayed on the display screen according to (a) temporal change(s) in at least one of the following: a) direction of force directed to the sensor surface, b) torque caused by combined effect of components of the force directed to the sensor surface, and c) strength of the force directed to the sensor surface. For example, a minimum strength of the force can be required in order to put the item to a wastebasket and items defined to be important may require stronger force than those items that have not been defined as important.

Figure 3a shows an electronic device 300 according to an embodiment of the invention. The electronic device can be, for example, a mobile communication terminal, a palm-top computer, a portable play station, or a combination of them. Figure 3b shows the A-A section view of the electronic device. A user interface of the electronic device comprises a sensor element 301 that has a sensor surface 302. A coordinate system 330 is shown for presentational purposes. The sensor element is arranged to produce a location indicator that is adapted to indicate a location of a spot of the sensor surface that is closest to an external object 320. The location indicator can express, for example, x- and y-coordinates of the spot closest to the external object. The sensor surface can be a touch sensitive sensor surface, a capacitive sensor surface, or a combined capacitive and touch sensitive sensor surface. The user interface comprises force sensor equipment arranged to produce a force indicator 325 that is adapted to indicate a temporal change of an x-component of force directed to the sensor surface and a temporal change of a y-component of the force directed to the sensor surface. The force sensor equipment comprises a ring-sensor 303a that is located around a rod 304 attached to the sensor element 301. The rod is supported with a flexible joint 306 to a casing 309 of the electronic device. The user interface comprises a processor unit 305 that is arranged to control the electronic device on the basis of the location indicator and the force indicator. The user interface comprises a display screen 331 with the aid of which visual information can be shown.

In an electronic device according to an embodiment of the invention, the force sensor equipment comprises a torsional sensor 303b arranged to detect torque caused by combined effect of the x-and y-components of the force directed to the sensor surface. The processor unit 305 is arranged to control the electronic device on the basis of the location indicator, the force indicator and the detected torque 326. The rod 304 can be (or include) a force detector arranged to detect the z-component of the force directed to the sensor surface in which case the processor unit 305 is preferably arranged to control the electronic device on the basis of also the detected z-component of the force.

In an electronic device according to an embodiment of the invention, the sensor surface 302 is a capacitive sensor surface and the processor unit 305 is arranged to move a cursor 313 on the display screen as a response to a situation in which a distance between the external object 320 and the sensor surface 302 is less than a pre-determined limit value and the external object is moved in the xy-plane. The cursor is moved on the display screen according to movements of the external object in the xy-plane. The processor unit 305 is arranged to highlight a symbol 311 displayed on the display screen as a response to e.g. a situation in which the external object 320 touches the sensor surface and the cursor 313 is pointing to the symbol. In other words, a symbol pointed to by the cursor can be selected for further actions by touching the sensor screen. The processor unit 305 is arranged to move the symbol 311 on the display screen as a response to e.g. a situation in which the external object touches the sensor surface, the cursor 313 is pointing to the symbol, and the external object directs to the sensor surface force that has a component parallel with the sensor surface and strength of the said component exceeds a pre-determined limit. The processor unit 305 is arranged to control the electronic device to execute a function related to the symbol 311 as a response to e.g. a situation in which a pre-determined change is detected in direction of the resultant of the x-and y-components of the force directed to the sensor surface and the cursor 213 is pointing to the symbol.

In an electronic device according to an embodiment of the invention, the sensor surface 302 is a touch sensitive sensor surface and the processor unit 305 is arranged to move the cursor 313 on the display screen as a response to a situation in which the external object 320 touches the sensor surface and the external object is moved on the sensor surface. The cursor is moved on the display screen according to movements of the external object on the sensor surface. The processor unit 305 is arranged to highlight a symbol 311 displayed on the display screen as a response to e.g. a situation in which the resultant of the x-and y-components of the force directed to the sensor surface is rotated clockwise and the cursor 213 is pointing to the symbol. In other words, a symbol pointed to by the cursor can be selected for further actions by rotating the resultant force clockwise. The processor unit 305 is arranged to move the symbol 311 on the display screen as a response to e.g. a situation in which the symbol has been highlighted, the cursor 313 is pointing to the symbol, and the external object is moved along the sensor surface. The processor unit 305 is arranged to control the electronic device to execute a function related to the symbol 311 as a response to e.g. a situation in which the symbol has been highlighted, the cursor 313 is pointing to the symbol, and the resultant of the x-and y-components of the force directed to the sensor surface is rotated counterclockwise.

Figure 4 shows an interface module 400 according to an embodiment of the invention. The interface module can be used as a building block of an electronic device that can be e.g. a mobile phone. The interface module comprises a sensor element 401 that has a

sensor surface 402. A coordinate system 430 is shown for presentational purposes. The sensor element is arranged to produce a location indicator that is adapted to indicate a location of a spot of the sensor surface that is closest to an external object. The interface module comprises force sensor equipment arranged to produce a force indicator that is adapted to indicate a temporal change of a first force component directed to the sensor surface and a temporal change of a second force component directed to the sensor surface, the first force component and the second force component being parallel with the sensor surface 402. The force sensor equipment comprises one or more force detectors that are located in layer 451 and/or in layer 452. The force detectors can be, for example, according to what is depicted in figures 1a - 1h. The interface module comprises a processor unit 405 that is capable of controlling an electronic device connected to the interface module on the basis of the location indicator and the force indicator. The interface module comprises connector pads 450 via which electrical signals can be conducted to/from the interface module.

In an interface module according to an embodiment of the invention, the force sensor equipment is arranged to produce another force indicator adapted to indicate a temporal change of a third force component directed to the sensor surface. The third force component is preferably the z-component of the force directed to the sensor surface. The processor unit is preferably arranged to control the electronic device on the basis of the location indicator, the force indicator (the x- and y- directions), and the other force indicator (the z-direction).

A user interface according to an embodiment of the invention comprises: (i) means for producing a location indicator that indicates a location of a spot of a sensor surface that is closest to an external object, (ii) means for producing a force indicator that indicates a temporal change of a first force component directed to the sensor surface and a temporal change of a second force component directed to the sensor surface, the first force component and the second force component being parallel with the sensor surface, and (iii) means for controlling an electronic device on the basis of the location indicator and the force indicator.

Figure 5 is a flow chart of a method according to an embodiment of the invention for controlling an electronic device. Phase 501 comprises producing a location indicator that indicates a location of a spot of a sensor surface that is closest to an external object. Phase 502 comprises producing a force indicator that indicates a temporal change of a first force component directed to the sensor surface and a temporal change of a second force component directed to the sensor surface, the first force component and the second force component being parallel with the sensor surface. Phase 503 comprises controlling the electronic device on the basis of the location indicator and the force indicator. The external object can be e.g. a finger of a user of the electronic device.

In a method according to an embodiment of the invention, the first force component and the second force component are detected in mutually intersecting directions.

5 In a method according to an embodiment of the invention, the first force component and the second force component are detected in directions substantially perpendicular with respect to each other.

In a method according to an embodiment of the invention, the location indicator indicates locations of two or more spots of the sensor surface which are simultaneously touched by two or more external objects.

10 In a method according to an embodiment of the invention, the first force component is detected at a first point of a sensor element that comprises the sensor surface and the second force component is detected at a second point of the sensor element.

15 In a method according to an embodiment of the invention, the electronic device is controlled to execute a pre-determined function as a response to a situation in which a pre-determined change is detected in one of the following: strength of the first force component and strength of the second force component.

In a method according to an embodiment of the invention, the electronic device is controlled to execute a pre-determined function as a response to a situation in which a pre-determined change is detected in a direction of a resultant of the first force component and the second force component; e.g. when the resultant is being rotated.

20 In a method according to an embodiment of the invention, the electronic device is controlled to execute a pre-determined function as a response to a situation in which a pre-determined change is detected in torque directed to the sensor surface by combined effect of the first force component and the second force component.

25 A method according to an embodiment of the invention comprises producing another force indicator that indicates a temporal change of a third force component directed to the sensor surface, the third force component being substantially perpendicular to the sensor surface and the electronic device being controlled on the basis of the location indicator, the force indicator, and the other force indicator.

30 In a method according to an embodiment of the invention, the sensor surface is a touch sensitive sensor surface arranged to produce the location indicator as a response to a situation in which the external object is touching the sensor surface.

35 In a method according to an embodiment of the invention, the sensor surface is a capacitive sensor surface arranged to produce the location indicator as a response to a situation in which a distance between the sensor surface and the external object is less than a pre-determined limit value.

In a method according to an embodiment of the invention, the force indicator is produced with force detectors connected to edges of the sensor element (e.g. figure 1a, 1b, or 1c) and arranged to detect the first force component and the second force component.

In a method according to an embodiment of the invention, the force indicator is produced with a ring-sensor arranged to detect the first force component and the second force component (e.g. figures 1f, 1g, and 1h), the ring-sensor being located around a rod attached to a sensor element comprising the sensor surface.

5 In a method according to an embodiment of the invention, the force indicator is produced with a torsional sensor arranged to detect torque caused by common effect of the first force component and the second force component (e.g. figures 1d and 1e).

10 In a method according to an embodiment of the invention, at least a part of the sensor surface is capable of operating as a display screen and visual information is displayed on the sensor surface.

In a method according to an embodiment of the invention, colors displayed on a display screen are changed according (a) temporal change(s) in at least one of the following: a) direction of a resultant of the first, second, and third force components, b) torque caused by combined effect of the first and second force components, and c) strength of the resultant of the first, second, and third force components.

15 In a method according to an embodiment of the invention, items displayed on the display screen are scrolled according to (a) temporal change(s) in at least one of the following: a) direction of a resultant of the first, second, and third force components, b) torque caused by combined effect of the first and second force components, and c) strength of the resultant of the first, second, and third force components. For example, scrolling direction (forward/backward) can depend on the direction of the resultant and scrolling speed can depend on the strength of the resultant.

20 In a method according to an embodiment of the invention, items displayed on the display screen are zoomed according to (a) temporal change(s) in at least one of the following: a) direction of a resultant of the first, second, and third force components, b) torque caused by combined effect of the first and second force components, and c) strength of the resultant of the first, second, and third force components. For example, zooming direction (zoom in/zoom out) can depend on the direction of the resultant and zooming speed can depend on the strength of the resultant.

30 In a method according to an embodiment of the invention, items displayed on the display screen are rotated according to (a) temporal change(s) in at least one of the following: a) direction of a resultant of the first, second, and third force components, b) torque caused by combined effect of the first and second force components, and c) strength of the resultant of the first, second, and third force components. For example, direction of rotation (clockwise/counterclockwise) can depend on the direction of the resultant and speed of the rotation can depend on the strength of the resultant.

35 In a method according to an embodiment of the invention, an action directed to an item displayed on the display screen is selected according to (a) temporal change(s) in at

least one of the following: a) direction of a resultant of the first, second, and third force components, b) torque caused by combined effect of the first and second force components, and c) strength of the resultant of the first, second, and third force components. For example, a minimum strength of the resultant can be required in order to put the item to a wastebasket and items defined to be important may require stronger resultant than those items that have not been defined as important.

A computer program according to an embodiment of the invention comprises computer executable instructions for making a processor unit to control an electronic device on the basis of:

- a location indicator that is adapted to indicate a location of a spot of a sensor surface that is closest to an external object, and
- a force indicator that is adapted to indicate a temporal change of a first force component directed to the sensor surface and a temporal change of a second force component directed to the sensor surface, the first force component and the second force component being parallel with the sensor surface.

The processor unit in which the computer program can be executed can be e.g. the processor unit 305 of the electronic device 300 shown in figure 3.

The computer executable instructions can be, for example, sub-routines and/or functions.

A computer program according to an embodiment of the invention comprises computer executable instructions for making the processor unit to control the electronic device also on the basis of another force indicator adapted to indicate a temporal change of a third force component directed to the sensor surface, the third force component being substantially perpendicular to the sensor surface.

A computer program according to an embodiment of the invention can be stored in a computer readable medium. The computer readable medium can be, for example, an optical compact disk or an electronic memory device like a RAM (random access memory) or a ROM (read only memory).

While there have been shown and described and pointed out fundamental novel features of the invention as applied to embodiments thereof, it will be understood that various omissions and substitutions and changes in the form and details of the devices and methods described may be made by those skilled in the art without departing from the scope of the inventive idea defined in the accompanied independent claims. For example, it is expressly intended that all combinations of those elements and/or method steps which perform substantially the same function in substantially the same way to achieve the same results are within the scope of the invention. Moreover, it should be recognized that structures and/or elements and/or method steps shown and/or described in connection with any disclosed form or embodiment of the invention may be incorporated in any other disclosed or described or suggested form or embodiment as a general matter of design choice. The spe-

cific examples provided in the description given above should not be construed as limiting. Therefore, the invention is not limited merely to the embodiments described above, many variants being possible without departing from the scope of the inventive idea defined in the accompanied independent claims.

What is claimed is:

1. A user interface comprising:
 - a sensor element having a sensor surface and being arranged to produce a location indicator that is adapted to indicate a location of a spot of the sensor surface that is closest to an external object,
 - force sensor equipment connected to the sensor element and arranged to produce a force indicator that is adapted to indicate a temporal change of a first force component directed to the sensor surface and a temporal change of a second force component directed to the sensor surface, the first force component and the second force component being parallel with the sensor surface, and
 - a processor unit capable of controlling an electronic device on the basis of the location indicator and the force indicator.
2. A user interface according to claim 1, wherein detection directions of the first force component and the second force component are mutually intersecting.
3. A user interface according to claim 2, wherein the detection directions of the first force component and the second force component are substantially perpendicular with respect to each other.
4. A user interface according to claim 1, wherein the force sensor equipment is arranged to detect the first force component at a first point of the sensor element and to detect the second force component at a second point of the sensor element.
5. A user interface according to claim 1, wherein the processor unit is capable of controlling the electronic device to execute a pre-determined function as a response to a situation in which a pre-determined change is detected in one of the following: strength of the first force component and strength of the second force component.
6. A user interface according to claim 1, wherein the processor unit is capable of controlling the electronic device to execute a pre-determined function as a response to a situation in which a pre-determined change is detected in a direction of a resultant of the first force component and the second force component.
7. A user interface according to claim 4, wherein the processor unit is capable of controlling the electronic device to execute a pre-determined function as a response to a situation in which a pre-determined change is detected in torque directed to the sensor surface by combined effect of the first force component and the second force component.

8. A user interface according to claim 1, wherein the force sensor equipment is arranged to produce an other force indicator adapted to indicate a temporal change of a third force component directed to the sensor surface, the third force component being substantially perpendicular to the sensor surface and the processor unit being capable of controlling the electronic device on the basis of the location indicator, the force indicator, and the other force indicator.
9. A user interface according to claim 1, wherein the sensor surface is a touch sensitive sensor surface arranged to produce the location indicator as a response to a situation in which the external object is touching the sensor surface.
10. A user interface according to claim 1, wherein the sensor surface is a capacitive sensor surface arranged to produce the location indicator as a response to a situation in which a distance between the sensor surface and the external object is less than a pre-determined limit value.
11. A user interface according to claim 1, wherein the force sensor equipment comprises force detectors connected to edges of the sensor element and arranged to detect the first force component and the second force component.
12. A user interface according to claim 1, wherein the force sensor equipment comprises a ring-sensor arranged to detect the first force component and the second force component, the ring-sensor being located around a rod attached to the sensor element.
13. A user interface according to claim 1, wherein the force sensor equipment comprises a torsional sensor arranged to detect torque caused by common effect of the first force component and the second force component.
14. A user interface according to claim 1, wherein at least a part of the sensor surface is capable of operating as a display screen.
15. A user interface according to claim 8, wherein the processor unit is capable of controlling the electronic device to change colors displayed on a display screen according (a) temporal change(s) in at least one of the following: a) direction of a resultant of the first, second, and third force components, b) torque caused by combined effect of the first and second force components, and c) strength of the resultant of the first, second, and third force components.
16. A user interface according to claim 8, wherein the processor unit is capable of controlling the electronic device to scroll items displayed on the display screen according to (a) temporal change(s) in at least one of the following: a) direction of a resultant of the

first, second, and third force components, b) torque caused by combined effect of the first and second force components, and c) strength of the resultant of the first, second, and third force components.

5 17. A user interface according to claim 8, wherein the processor unit is capable of controlling the electronic device to zoom items displayed on the display screen according to (a) temporal change(s) in at least one of the following: a) direction of a resultant of the first, second, and third force components, b) torque caused by combined effect of the first and second force components, and c) strength of the resultant of the first, second, and third force components.

10 18. A user interface according to claim 8, wherein the processor unit is capable of controlling the electronic device to rotate items displayed on the display screen according to (a) temporal change(s) in at least one of the following: a) direction of a resultant of the first, second, and third force components, b) torque caused by combined effect of the first and second force components, and c) strength of the resultant of the first, second, and third
15 force components.

19. A user interface according to claim 8, wherein the processor unit is capable of controlling the electronic device to select an action directed to an item displayed on the display screen according to (a) temporal change(s) in at least one of the following: a) direction of a
20 resultant of the first, second, and third force components, b) torque caused by combined effect of the first and second force components, and c) strength of the resultant of the first, second, and third force components.

20. A user interface according to claim 1, wherein the location indicator is adapted to indicate locations of two or more spots of the sensor surface which are simultaneously touched by two or more external objects.

25 21. A method comprising:
- producing a location indicator that indicates a location of a spot of a sensor surface that is closest to an external object,
- producing a force indicator that indicates a temporal change of a first force component directed to the sensor surface and a temporal change of a second force component directed to the sensor surface, the first force component and the second force
30 component being parallel with the sensor surface, and
- controlling an electronic device on the basis of the location indicator and the force indicator.

22. A method according to claim 21, wherein the first force component and the second force component are detected in mutually intersecting directions.
23. A method according to claim 22, wherein the first force component and the second force component are detected in directions substantially perpendicular with respect to each other.
- 5
24. A method according to claim 21, wherein the first force component is detected at a first point of a sensor element that comprises the sensor surface and the second force component is detected at a second point of the sensor element.
25. A method according to claim 21, wherein the electronic device is controlled to execute a pre-determined function as a response to a situation in which a pre-determined change is detected in one of the following: strength of the first force component and strength of the second force component.
- 10
26. A method according to claim 21, wherein the electronic device is controlled to execute a pre-determined function as a response to a situation in which a pre-determined change is detected in a direction of a resultant of the first force component and the second force component.
- 15
27. A method according to claim 24, the electronic device is controlled to execute a pre-determined function as a response to a situation in which a pre-determined change is detected in torque directed to the sensor surface by combined effect of the first force component and the second force component.
- 20
28. A method according to claim 21, wherein the method comprises producing another force indicator that indicates a temporal change of a third force component directed to the sensor surface, the third force component being substantially perpendicular to the sensor surface and the electronic device being controlled on the basis of the location indicator, the force indicator, and the other force indicator.
- 25
29. A method according to claim 21, wherein the sensor surface is a touch sensitive sensor surface arranged to produce the location indicator as a response to a situation in which the external object is touching the sensor surface.
30. A method according to claim 21, wherein the sensor surface is a capacitive sensor surface arranged to produce the location indicator as a response to a situation in which a distance between the sensor surface and the external object is less than a pre-determined limit value.
- 30

31. A method according to claim 21, wherein the force indicator is produced with force detectors connected to edges of the sensor element and arranged to detect the first force component and the second force component.
- 5 32. A method according to claim 21, wherein the force indicator is produced with a ring-sensor arranged to detect the first force component and the second force component, the ring-sensor being located around a rod attached to a sensor element comprising the sensor surface.
- 10 33. A method according to claim 21, wherein the force indicator is produced with a torsional sensor arranged to detect torque caused by common effect of the first force component and the second force component.
34. A method according to claim 21, wherein at least a part of the sensor surface is capable of operating as a display screen and visual information is displayed on the sensor surface.
- 15 35. A method according to claim 28, wherein colors displayed on a display screen are changed according (a) temporal change(s) in at least one of the following: a) direction of a resultant of the first, second, and third force components, b) torque caused by combined effect of the first and second force components, and c) strength of the resultant of the first, second, and third force components.
- 20 36. A method according to claim 28, wherein items displayed on the display screen are scrolled according to (a) temporal change(s) in at least one of the following: a) direction of a resultant of the first, second, and third force components, b) torque caused by combined effect of the first and second force components, and c) strength of the resultant of the first, second, and third force components.
- 25 37. A method according to claim 28, wherein items displayed on the display screen are zoomed according to (a) temporal change(s) in at least one of the following: a) direction of a resultant of the first, second, and third force components, b) torque caused by combined effect of the first and second force components, and c) strength of the resultant of the first, second, and third force components.
- 30 38. A method according to claim 28, wherein items displayed on the display screen are rotated according to (a) temporal change(s) in at least one of the following: a) direction of a resultant of the first, second, and third force components, b) torque caused by combined effect of the first and second force components, and c) strength of the resultant of the first, second, and third force components.

39. A method according to claim 28, wherein an action directed to an item displayed on the display screen is selected according to (a) temporal change(s) in at least one of the following: a) direction of a resultant of the first, second, and third force components, b) torque caused by combined effect of the first and second force components, and c) strength of the resultant of the first, second, and third force components.
40. A method according to claim 21, wherein the location indicator indicates locations of two or more spots of the sensor surface which are simultaneously touched by two or more external objects.
41. An electronic device comprising:
- a sensor element having a sensor surface and being arranged to produce a location indicator that is adapted to indicate a location of a spot of the sensor surface that is closest to an external object,
 - force sensor equipment connected to the sensor element and arranged to produce a force indicator that is adapted to indicate a temporal change of a first force component directed to the sensor surface and a temporal change of a second force component directed to the sensor surface, the first force component and the second force component being parallel with the sensor surface, and
 - a processor unit arranged to control the electronic device on the basis of the location indicator and the force indicator.
42. An electronic device according to claim 41, wherein the force sensor equipment is arranged to produce another force indicator adapted to indicate a temporal change of a third force component directed to the sensor surface, the third force component being substantially perpendicular to the sensor surface and the processor unit being arranged to control the electronic device on the basis of the location indicator, the force indicator, and the other force indicator.
43. An electronic device according to claim 41, wherein the electronic device is at least one of the following: a mobile communication terminal, a palmtop computer, and a portable play station.
44. A computer readable medium encoded with computer executable instructions for making a processor unit to control an electronic device on the basis of:
- a location indicator that is adapted to indicate a location of a spot of a sensor surface that is closest to an external object, and
 - a force indicator that is adapted to indicate a temporal change of a first force component directed to the sensor surface and a temporal change of a second force com-

ponent directed to the sensor surface, the first force component and the second force component being parallel with the sensor surface.

45. A computer readable medium according to claim 44, wherein the computer readable medium is encoded with computer executable instructions for making the processor unit to control the electronic device also on the basis of another force indicator adapted to indicate a temporal change of a third force component directed to the sensor surface, the third force component being substantially perpendicular to the sensor surface.

46. An interface module comprising:

- a sensor element having a sensor surface and being arranged to produce a location indicator that is adapted to indicate a location of a spot of the sensor surface that is closest to an external object,
- force sensor equipment connected to the sensor element and arranged to produce a force indicator that is adapted to indicate a temporal change of a first force component directed to the sensor surface and a temporal change of a second force component directed to the sensor surface, the first force component and the second force component being parallel with the sensor surface, and
- a processor unit capable of controlling an electronic device connected to the interface module on the basis of the location indicator and the force indicator.

47. An interface module according to claim 46, wherein the force sensor equipment is arranged to produce another force indicator adapted to indicate a temporal change of a third force component directed to the sensor surface, the third force component being substantially perpendicular to the sensor surface and the processor unit being capable of controlling the electronic device on the basis of the location indicator, the force indicator, and the other force indicator.

48. A user interface comprising:

- means for producing a location indicator that indicates a location of a spot of a sensor surface that is closest to an external object,
- means for producing a force indicator that indicates a temporal change of a first force component directed to the sensor surface and a temporal change of a second force component directed to the sensor surface, the first force component and the second force component being parallel with the sensor surface, and
- means for controlling an electronic device on the basis of the location indicator and the force indicator.

1 / 7

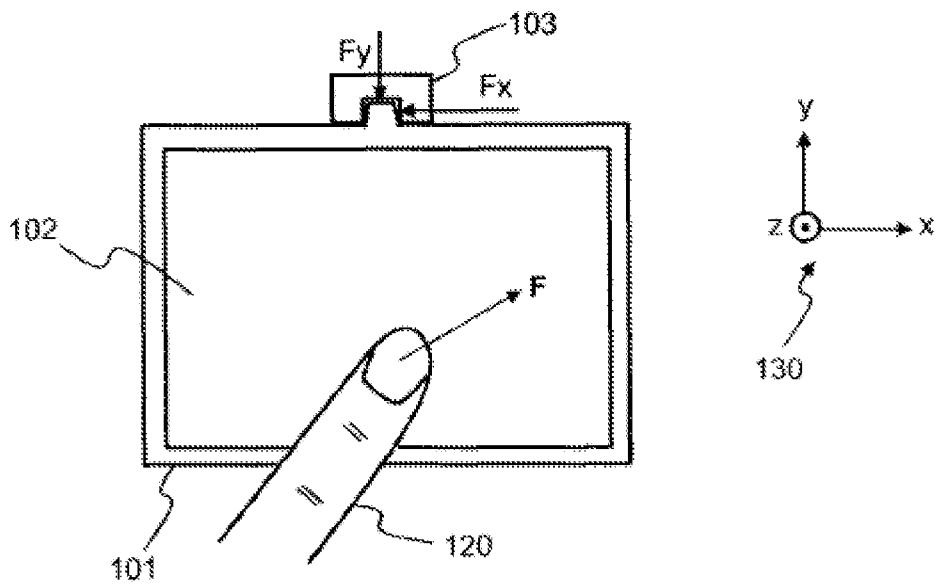

Fig. 1a

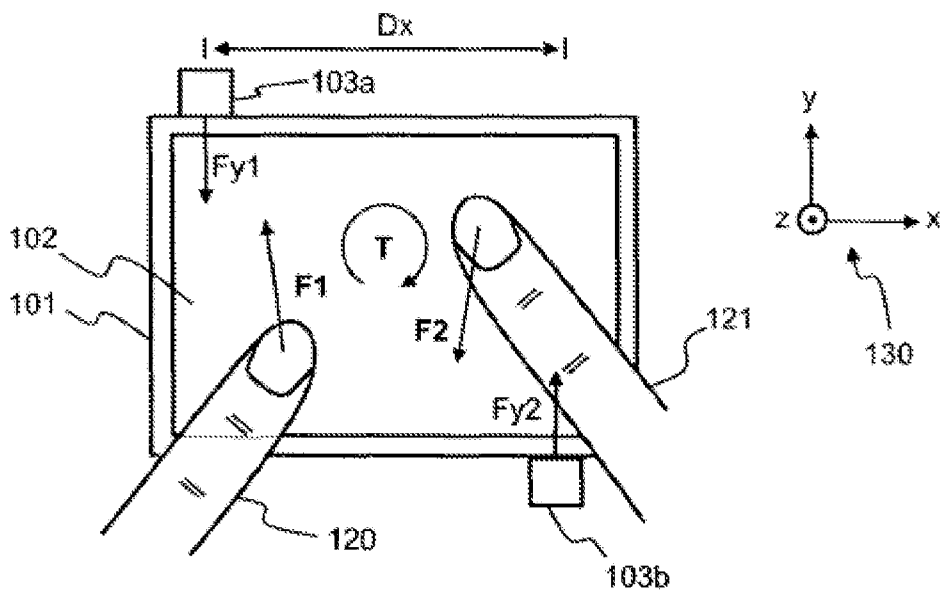

Fig. 1b

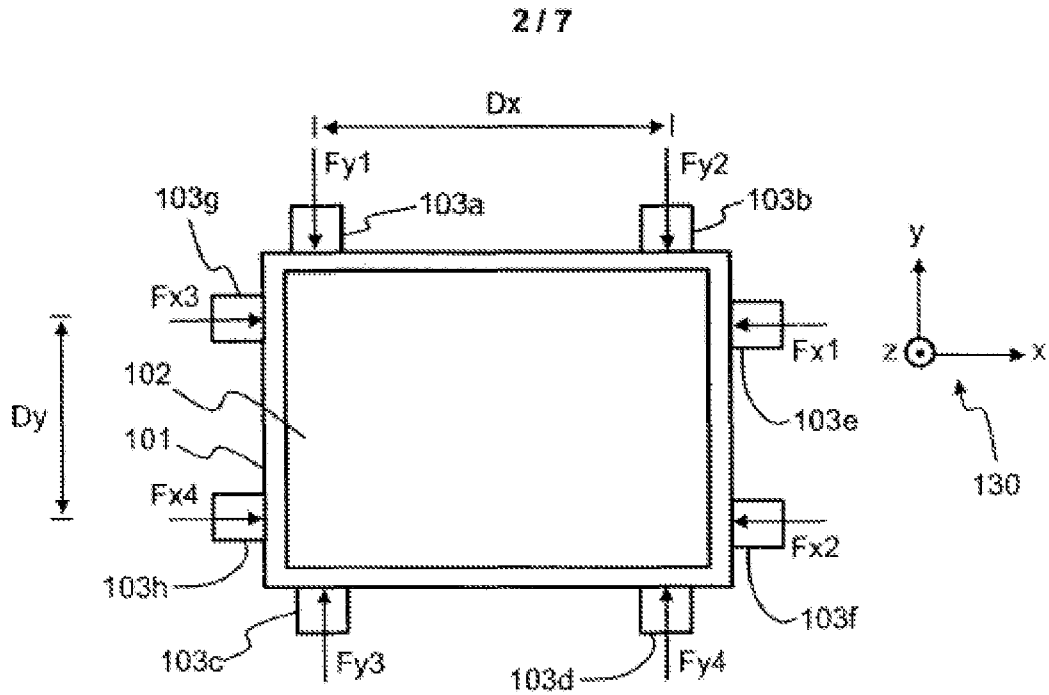

Fig. 1c

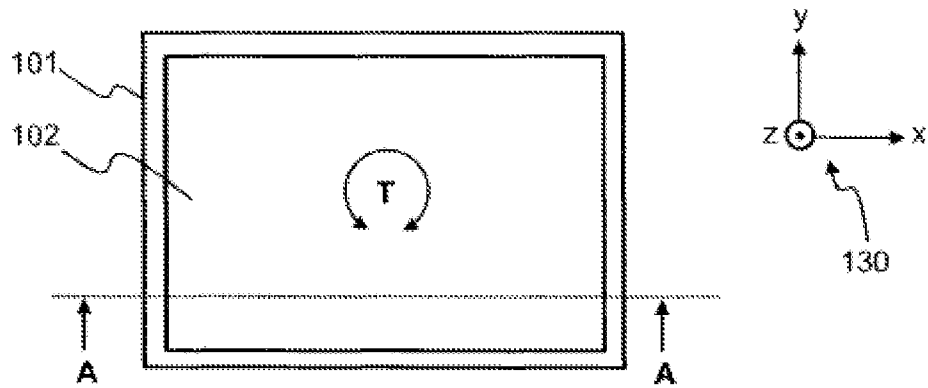

Fig. 1d

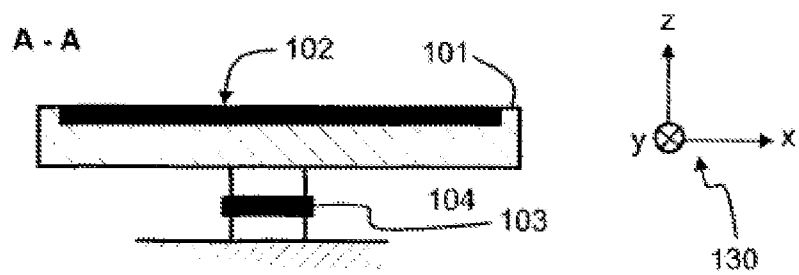

Fig. 1e

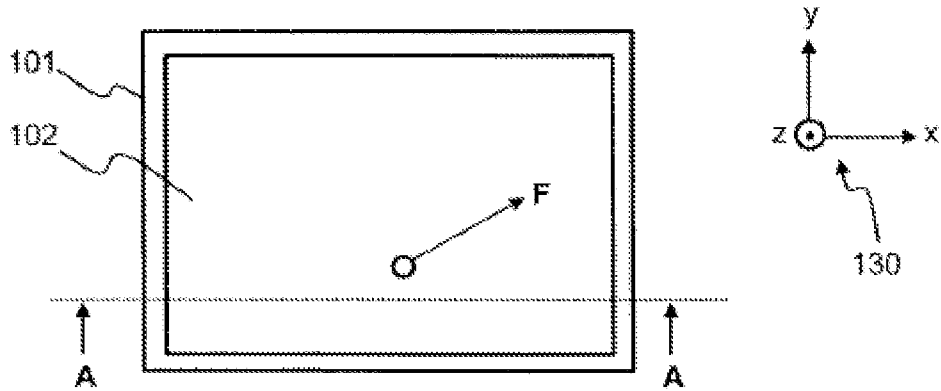

Fig. 1f

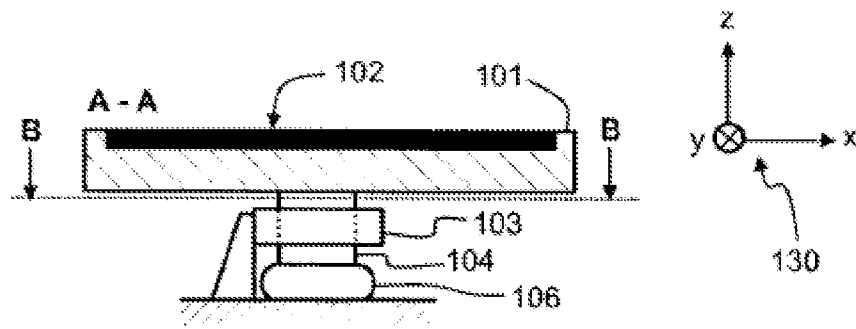

Fig. 1g

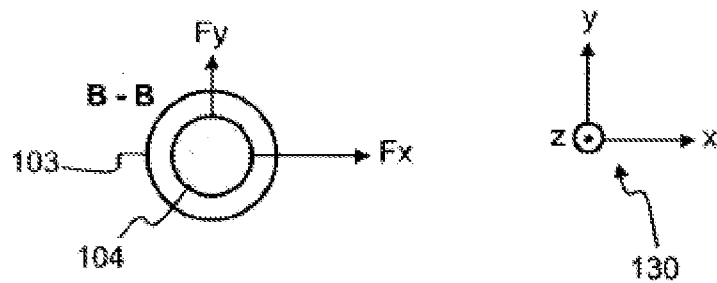

Fig. 1h

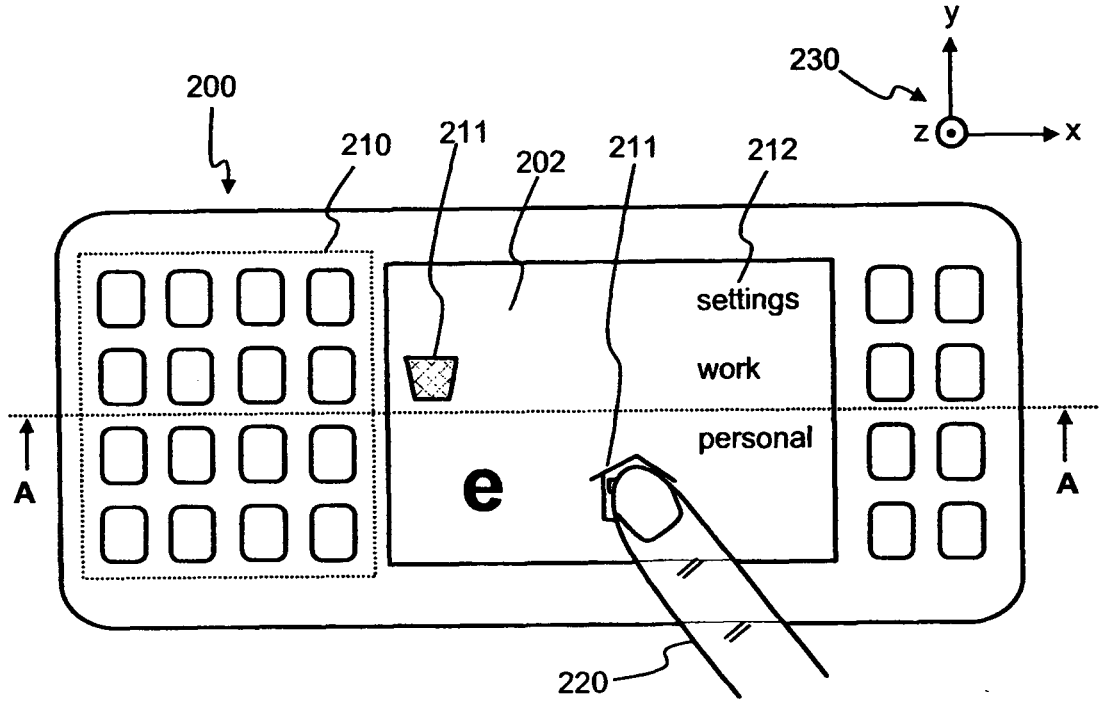

Fig. 2a

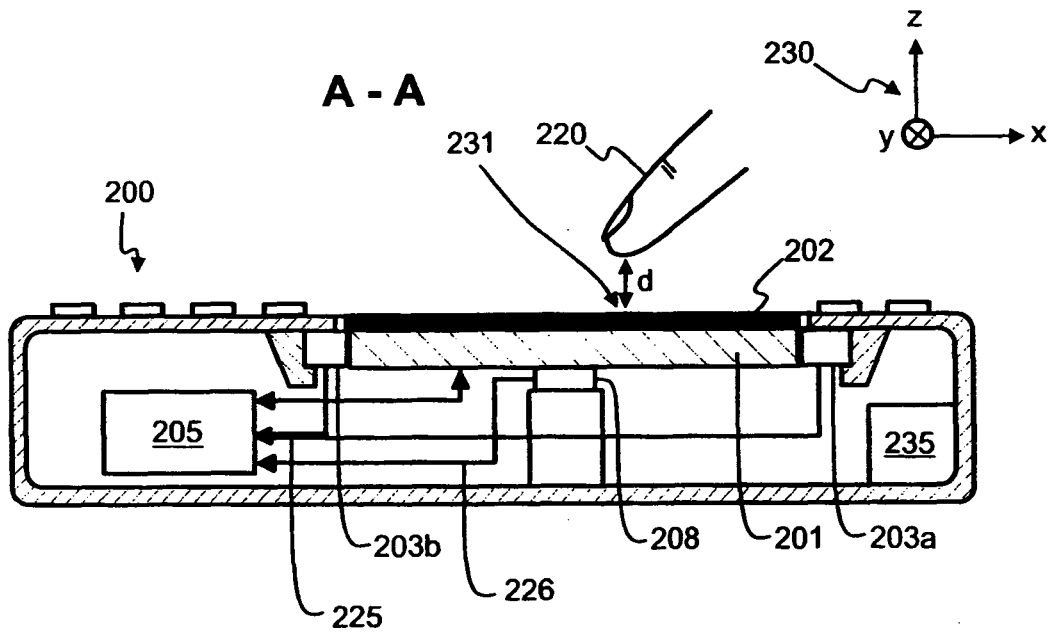

Fig. 2b

517

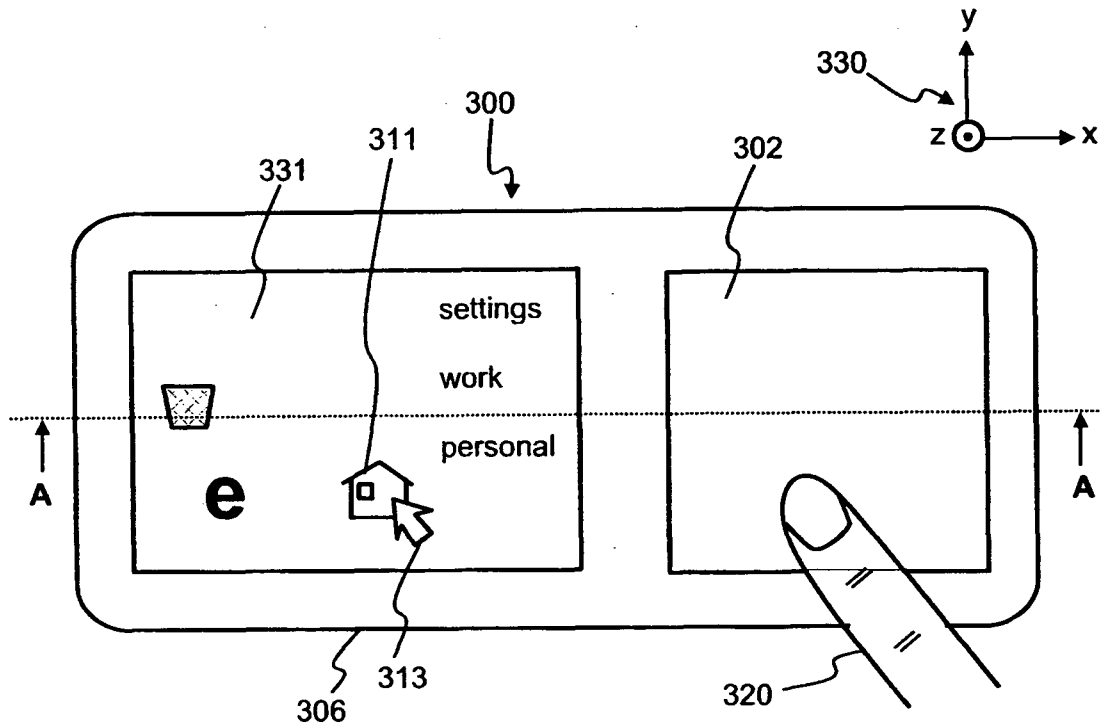

Fig. 3a

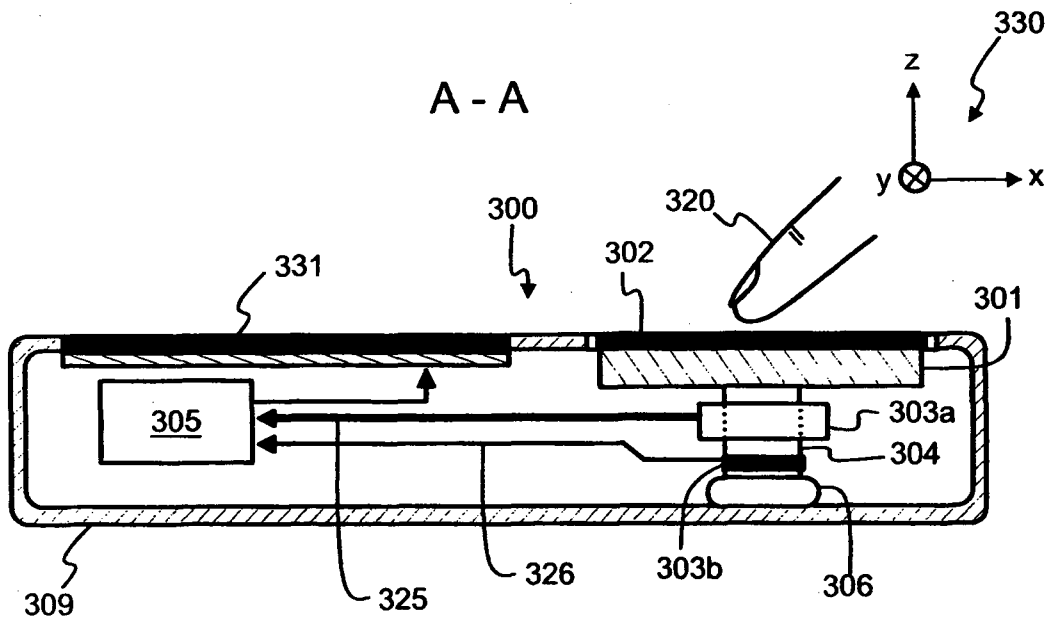

Fig. 3b

6 / 7

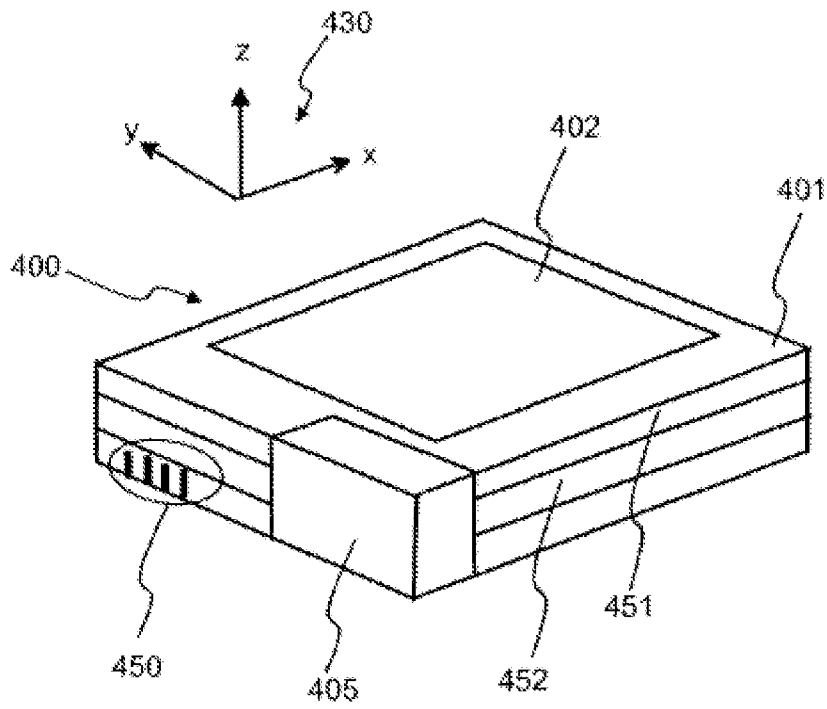

Fig. 4

717

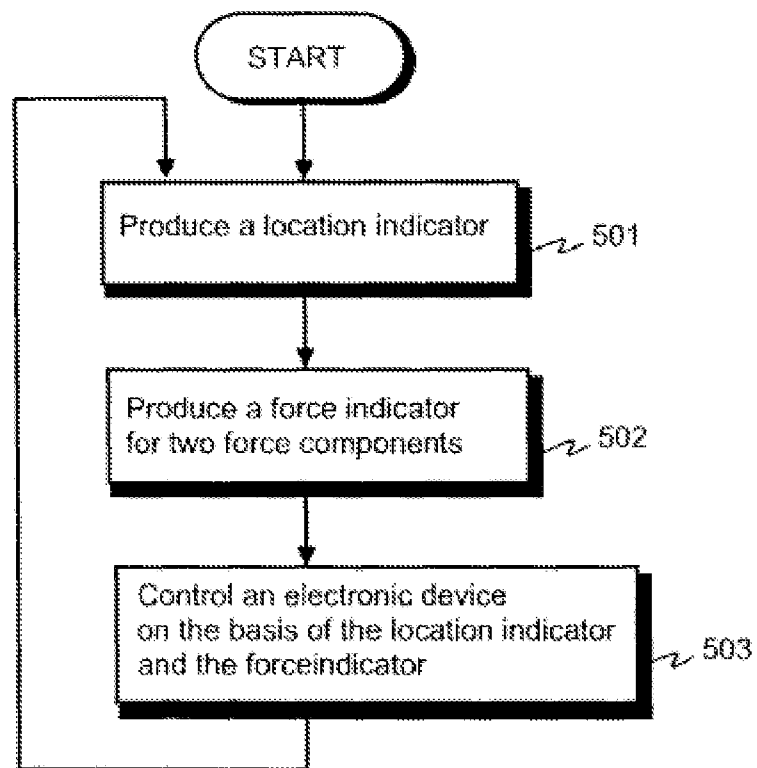

Fig. 5

INTERNATIONAL SEARCH REPORT

International application No.

PCT/FI2009/050253

A. CLASSIFICATION OF SUBJECT MATTER See extra sheet According to International Patent Classification (IPC) or to both national classification and IPC		
B. FIELDS SEARCHED Minimum documentation searched (classification system followed by classification symbols) IPC: G06F Documentation searched other than minimum documentation to the extent that such documents are included in the fields searched FI, SE, NO, DK Electronic data base consulted during the international search (name of data base and, where practicable, search terms used) EPO-Internal, WPI, Internet		
C. DOCUMENTS CONSIDERED TO BE RELEVANT		
Category*	Citation of document, with indication, where appropriate, of the relevant passages	Relevant to claim No.
X	US 6492979 B1 (KENT, J et al.) 10 December 2002 (10.12.2002), abstract; column 1, lines 18-29 and 50-51; column 2, line 54 – column 3, line 61; column 4, lines 32-39; column 5, lines 36-49; column 11, line 63 – column 12, line 10; Fig. 3	1-48
X	EP 0640936 A1 (PHILIPS ELECTRONICS NV) 01 March 1995 (01.03.1995), abstract; column 1, lines 9-55; column 4, line 52 – column 5, line 2; column 5, lines 24-26; column 7, lines 19-36; Fig. 1	1-48
A	EP 1852774 A2 (MITSUBISHI ELECTRIC CORPORATION) 07 November 2007 (07.11.2007), abstract; paragraphs [0033], [0034], [0041], [0042]; Figs 2 and 3	1-48
<input type="checkbox"/> Further documents are listed in the continuation of Box C. <input checked="" type="checkbox"/> See patent family annex.		
* Special categories of cited documents: "A" document defining the general state of the art which is not considered to be of particular relevance "E" earlier application or patent but published on or after the international filing date "L" document which may throw doubts on priority claim(s) or which is cited to establish the publication date of another citation or other special reason (as specified) "O" document referring to an oral disclosure, use, exhibition or other means "P" document published prior to the international filing date but later than the priority date claimed		"T" later document published after the international filing date or priority date and not in conflict with the application but cited to understand the principle or theory underlying the invention "X" document of particular relevance; the claimed invention cannot be considered novel or cannot be considered to involve an inventive step when the document is taken alone "Y" document of particular relevance; the claimed invention cannot be considered to involve an inventive step when the document is combined with one or more other such documents, such combination being obvious to a person skilled in the art "&" document member of the same patent family
Date of the actual completion of the international search 28 August 2009 (28.08.2009)		Date of mailing of the international search report 31 August 2009 (31.08.2009)
Name and mailing address of the ISA/FI National Board of Patents and Registration of Finland P.O. Box 1160, FI-00101 HELSINKI, Finland Facsimile No. +358 9 6939 5328		Authorized officer Timo Huttunen Telephone No. +358 9 6939 500

INTERNATIONAL SEARCH REPORT
Information on patent family members

International application No.
PCT/FI2009/050253

Patent document cited in search report	Publication date	Patent family members(s)	Publication date
US 6492979 B1	10/12/2002	None	
.....			
EP 0640936 A1	01/03/1995	DE 69421478T T2 JP 7064725 A US 5510813 A BE 1007462 A3	18/05/2000 10/03/1995 23/04/1996 04/07/1995
.....			
EP 1852774 A2	07/11/2007	JP 2007299384 A US 2007257891 A1	15/11/2007 08/11/2007
.....			

INTERNATIONAL SEARCH REPORT

International application No.
PCT/FI2009/050253

CLASSIFICATION OF SUBJECT MATTER

Int.Cl.

G06F 3/033 (2006.01)

G06F 3/041 (2006.01)