

Nov. 18, 1924.

1,515,697

E. R. POPE
NAILING MACHINE

Filed Oct. 11, 1922

2 Sheets-Sheet 1

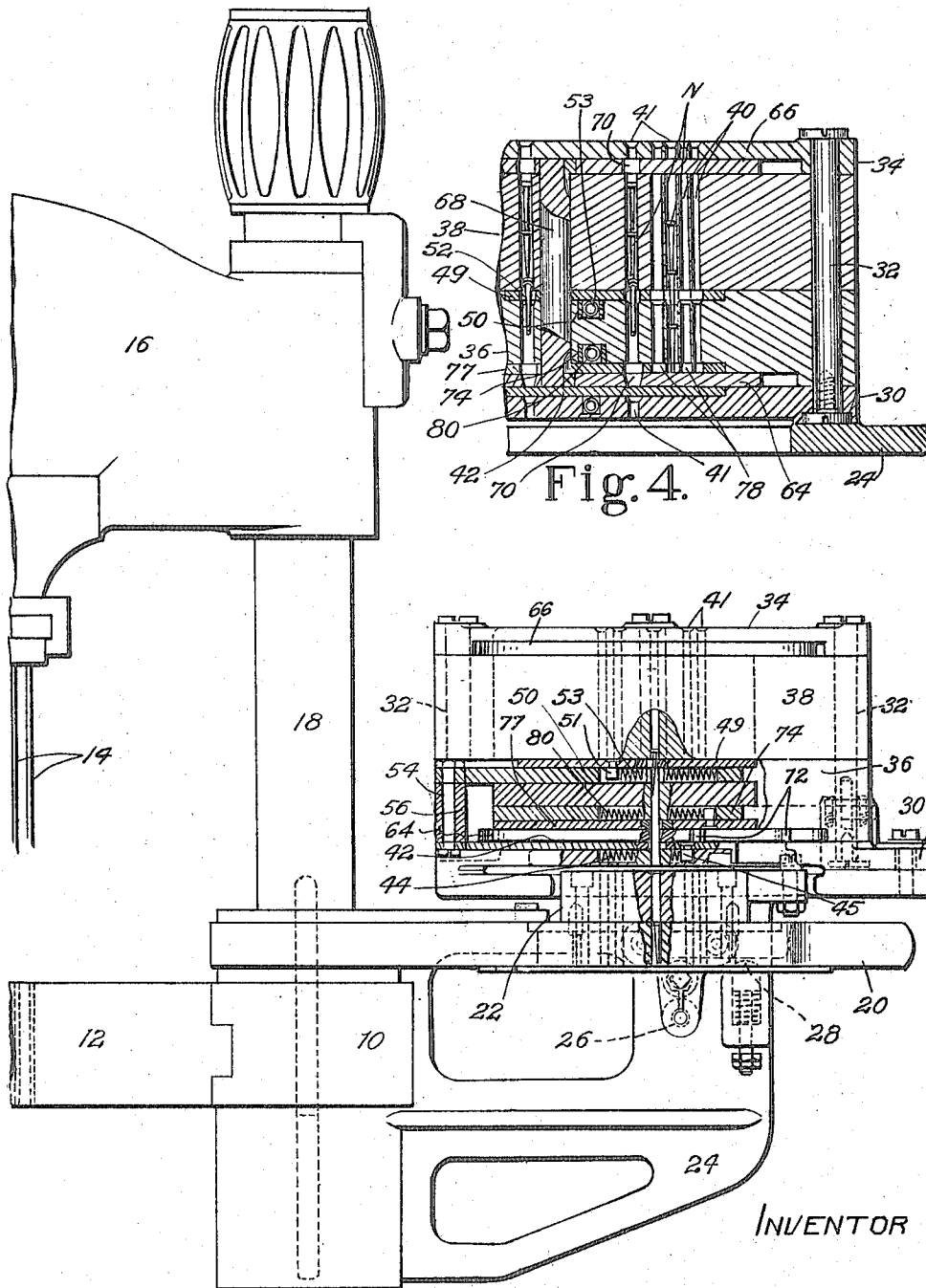

Fig. 1.

Fig. 4.

INVENTOR

Elmer R. Pope

Nov. 18, 1924.

1,515,697

E. R. POPE

NAILING MACHINE

Filed Oct. 11, 1922

2 Sheets-Sheet 2

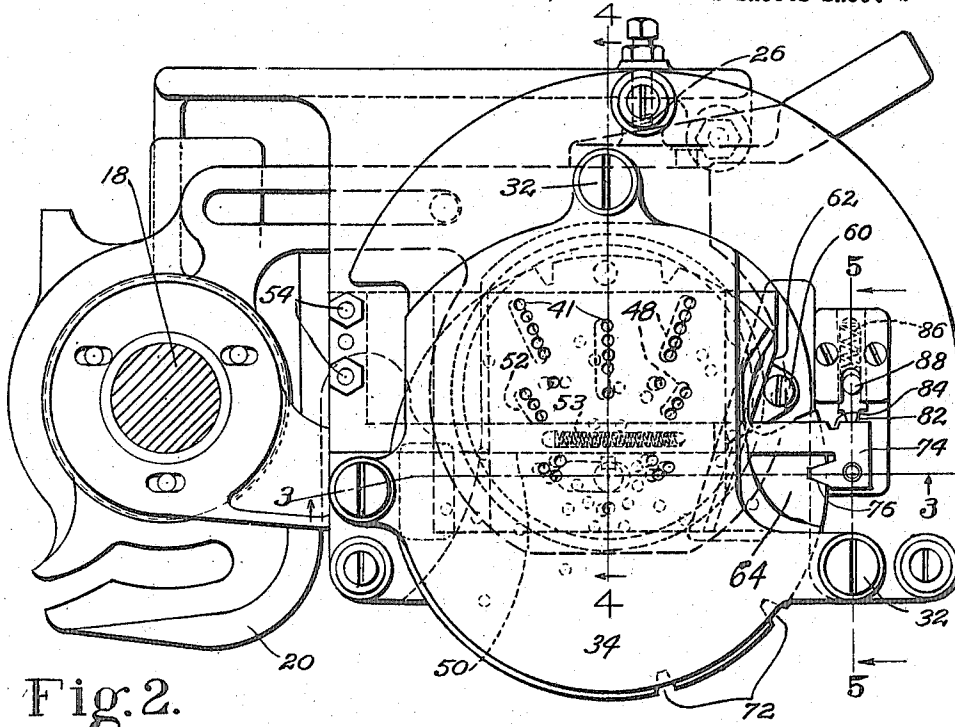

Fig. 2.

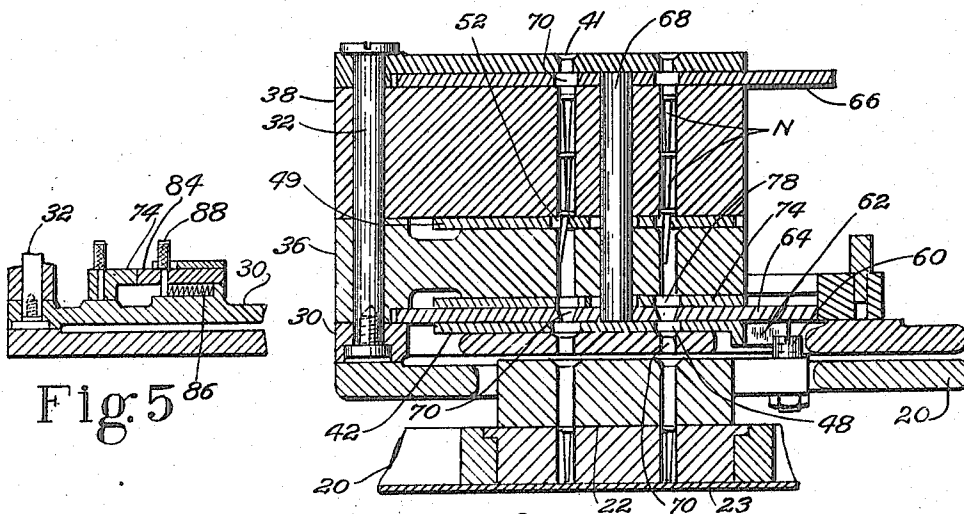

Fig. 5

Fig. 3.

INVENTOR

UNITED STATES PATENT OFFICE.

ELMER R. POPE, OF HAMILTON, MASSACHUSETTS, ASSIGNOR TO UNITED SHOE MACHINERY CORPORATION, OF PATERSON, NEW JERSEY, A CORPORATION OF NEW JERSEY.

NAILING MACHINE.

Application filed October 11, 1922. Serial No. 593,876.

To all whom it may concern:

Be it known that I, ELMER R. POPE, a citizen of the United States, residing at Hamilton, in the county of Essex and State of Massachusetts, have invented certain Improvements in Nailing Machines, of which the following description, in connection with the accompanying drawings, is a specification, like reference characters on the drawings indicating like parts in the several figures.

This invention relates to nailing machines, and especially to those for attaching heels to shoes. It more particularly concerns itself with the supplying in such machines of the nails to be driven.

In heeling shoes, the practice heretofore has been to deliver nails to the die-block of the heeler by a loader, into which said nails were either fed manually by the operator's assistant, or supplied automatically by nail-distributing mechanism. An organization of the character first indicated is illustrated in Patent No. 446,885, Pope, February 24, 1891, while that last mentioned is shown in Patent No. 1,005,303, Pope, October 10, 1911 taken in connection with No. 1,157,688, Glidden, October 26, 1915. Under the first method, the operator tends to attach the heels more quickly than one assistant can supply the nails for them, thus placing a drag upon the work. If two assistants are employed, as is provided for in Patent No. 1,005,303, the expense is, of course, considerably increased. Automatic nail-feeding requires the use of mechanisms relatively costly to construct and maintain. My invention, keeping the simplicity of hand feeding, provides, as an object, for a reserve supply of nails, which may be built up at such time as the activities of the operator are reduced, and drawn upon when the assistant might otherwise fall behind. To accomplish this, the nails are held in series in passages in a magazine, to be successively delivered one by one from each passage by controlling means, with which is associated means for retaining the succeeding nails of a series during the feed of the terminal nail. Since the nailing design, that is, the points at which the nails are inserted in the heels, changes frequently, according to the size or style of shoe operated upon, the magazine-passages are arranged in sets in accordance with the various de-

signs to be employed, and I furnish means for permitting the delivery of the nails from any one of the sets while the other sets remain ineffective. This control may be exercised at both extremities of the passages, allowing for preventing both the introduction of nails to and their delivery from the passages. With the controlling means is associated means for determining its position, and consequently the particular set of passages which shall be in use, and I guard against interference with the positioning of the controlling means by the nails, as by causing this position-determining means to control the movement of the nails in the magazine, preferably by contact with them.

One of the various embodiments which my invention may assume is shown in the accompanying drawings,

Fig. 1 being a front elevation of a portion of a nailing machine to which my invention is applied;

Fig. 2, a top plan view of the nail-holding magazine;

Fig. 3, a vertical section on the line 3—3 of Fig. 2;

Fig. 4, a similar view on the line 4—4 of Fig. 2; and

Fig. 5, a sectional detail on the line 5—5 of Fig. 2.

At 10 appears the frame of a heel-attaching machine, upon which is supported a die-block 12, preferably having multiple sets of nail-receiving openings, each set corresponding to the design which the nailing is to assume for a particular size and form of heel to be attached. Operating in these openings are drivers 14 depending from a top girth 16 bridging the reciprocatory side rods of the machine, one of which rods is shown at 18. Surrounding the side rod, to swing from a nail-delivering position over the die-block-openings to a nail-receiving position at one side of the machine, is a loader-arm 20, carrying at its outer extremity a loader-block 22. This block has in it multiple sets of openings, controlled by a nail-supporting shutter 23 and arranged similarly to those in the die-block, it serving to carry loads of nails to said die-block for the heel-attaching operation.

Fixed upon the frame of the machine, adjacent to the point at which the loader-arm 20 is mounted, is a bracket 24, which carries

a stop 26 limiting the outward movement of the loader-arm, and a latch 28, by which said loader-arm may be temporarily retained in its nail-receiving position. Secured to the upper face of the bracket is the base-section 30 of a nail-magazine, and rising from this base are studs 32, shown as three in number, holding at their upper ends a top plate 34. Between the base and top plate, positioned by the studs, is a block consisting of a lower section 36 and an upper section 38, furnishing the body of the nail-magazine. Extending in a substantially vertical direction through the block-sections are nail-holding passages 40, these, like those of the loader-block and die-block, being arranged in multiple sets comprehending all the nailing designs. Openings 41 in the top plate and base are alined with these passages to allow the introduction and delivery of the contained nails.

The lower extremities of the passages 40 are normally closed by a plate 42 mounted to slide at the bottom of a space between the base 30 and the block-section 36. To hold this plate normally in its nail-supporting position, with its imperforate portions in alinement with the passages 40, a spring 44, situated in a recess in the base, exerts its force upon the plate through a pin 45 projecting downwardly from the latter. When the passages in the magazine are thus closed, the nails in each are arranged in a continuous series, the lowest resting with one extremity upon the plate, while each succeeding nail is supported by that beneath it, the transverse dimensions of the passages being such that but a single nail at a time can travel through any portion. The height of the passages is sufficient to allow a substantial number of nails to be maintained in each series, which, as shown in the drawing, for the particular size of nail illustrated, consists of four. Adjacent to the imperforate nail-supporting portions of the plate 42 are openings 48, which, upon movement of the plate against the spring 44, may be brought opposite the lower extremities of all the passages, thus freeing these for the delivery of the terminal nails. As is best shown in Fig. 2 of the drawings, these openings need not be individual to the passages, but may in some instances be enlarged to correspond to a group of these. With the succeeding nails of the series co-operates a member consisting of an L-shaped supporting plate 50 and a contact-plate 49 carried on the upper face of the plate 50, both being arranged to slide between the sections 36 and 38 of the magazine-block. In the plate 50 is a slot receiving a pin 51 depending from the companion plate, and between the pin and an extremity of the slot is a spring 53, acting to force the contact-plate to the left, as viewed in Fig. 1 of the drawings.

Through the plate 49 are openings 52, corresponding in number and form to the openings 48, but not having the same positions transversely of the passages. The relation of the openings 52 and 48 is such that when the plate 42 is moved to free the ends of the passages, the edges of the openings 52 in the contact-plate bear against the side of the nails next to those to be delivered to clamp them yieldably, and hold them and those which they support against downward displacement. With the plate 42 in its nail-retaining position, the openings 52 of the plate 49 move into alinement with the passages 40, so that they no longer act upon the nails. The plates 42 and 50 are preferably connected to move together, there being shown for this purpose bolts 54, 54, which secure them to the upper and lower faces of a spacing block 56. Consequently, the contact-plate 49 is under the normal positioning influence of the spring 44. The movement of the plates is under the control of the loader-arm 20, this having an upward projection 60 arranged to contact with an inclined or cam-surface 62 upon the outer edge of the plate 42. With the loader-arm in any position other than that in which it is latched by the device 28, the projection 60 is out of contact with the cam-surface 62. At this time the spring 44 holds the plate 42 in its nail-retaining position, and the plates 50 and 49 with the openings 52 substantially coinciding with the passages. When, however, the loader-arm is swung back fully to its nail-receiving position and latched, the projection 60 rides over the surface 62, forcing the plates 42, 50 and 49 to the left, as viewed in Figs. 2 and 3 of the drawings, causing the first-mentioned plate to open the passages and the plate 49 to bear against and hold the succeeding nails, so that the terminal nails only fall from the magazine into the loader-block-openings ready for delivery to the die-block.

To render a particular set of passages effective, so that in the movement of the plates by the loader-arm the nails delivered from the magazine to the loader block shall be arranged in accordance with the design in which they are to be placed in the heel of the shoe operated upon, there is associated with the magazine controlling means, here shown as including two plates or disks 64 and 66, which are respectively located between the section 36 of the magazine and the base and between the section 38 of said magazine and the top plate. The disks are fixed upon a spindle 68 journaled vertically in the magazine-sections, and contain vertically alined openings 70. These openings, like those in the die-block, loader-block and magazine, include sets for all the nailing designs, and are so arranged that

by rotating the disks to different angles, one or another of the sets may be caused to coincide with the passages in the magazine, at which time all the other sets of passages are closed. Different settings of the disk provide for the rendering effective of all the sets of magazine-passages.

To permit the selection and temporary retention of the design which is to be utilized for any heel operated upon, the periphery of the plate 64 has, at 72, a series of recesses, each recess corresponding to one of the settings of the magazine, and having, if desired, inscribed upon the upper surface of the plate adjacent to it an identifying designation for this design. With these recesses 72 co-operates a position-determining member 74, mounted to slide between the disk 64 and the magazine-section 36 and having a projection 76 so formed that it will enter any one of the recesses brought into registration with it and hold the selected setting of the controlling disks. The portion of the member 74 lying between the disk and magazine-section has movable with it, arranged to yield against a spring 80, an auxiliary plate 77, acting similarly to the contact-plate 49 and having openings 78 co-operating with the passages 40. When the projection 76 lies within one of the disk-recesses, these openings are opposite the passages, leaving these free for the movement of the nails. When the projection is drawn out of the recess which it may occupy, the edges of the openings 78 are brought into contact with the terminal nails in the passages, clamping these and the nails which they support against downward movement, and thus preventing their interference with the setting of the disk by entering its openings. It is to be noted that this interference would not be caused by nails in the passages which are in use, since here the lowest nails have been delivered, and those succeeding them retained by the plate 49. There may, however, be idle series in the unused passages of other sets, which would fall into the disk-openings were precautions not taken to avoid this. To allow for the convenient setting of the disks and the nail-retaining action just described, there is mounted, adjacent to the member 74, to slide upon the base 30, a latch 82 arranged to enter a recess 84 in the member 74, this engagement taking place when the projection 76 is withdrawn from the disk-recesses 72. A spring 86 acts upon the latch 82 to force it toward the recess 84 which it is to enter. To free the member 74 to permit it to be moved to its inmost setting-retaining position, a finger-piece 88 appears rising from the latch, by which it may be drawn out of the recess 84.

In using the apparatus, let it be assumed that the disks 64 and 66 have been set for

some particular nailing design which has been in use, and that there are nails N within the magazine-passages 40. The operator, now desiring to use another nailing design, draws out the member 74 until it is latched at 82. At this time, the projection 76 has freed the disk 64, and the edges of the openings 78 in the member 74 are holding any nails which may be contained in previously unused sets of passages so that they are resting upon the disk. The operator now turns this disk to the desired angular position, shown by the marking associated with the recesses 72, and draws back the latch by its finger-piece 88 to allow the position-determining projection to enter the recess which is opposite it. This movement of the member 74 not only locks the disk for the new design, but also releases all the nails which it may have been engaging. With the loader-arm away from the latch 28, the lower extremities of the selected set of passages are closed by the plate 42. Consequently, the operator's assistant, at any time free from other duties, may supply nails to the magazine-passages through the openings 41 in the top plate and in the disk 66, the other passages than those of the set selected being closed by the perforate portions of the plate. When a load of nails is to be delivered to the die-block, the operator's assistant swings the loader-arm to its extreme outward position against the stop 26, and when it is engaged by the latch 28, its projection 60, acting against the surface 62, cams over the plates 42, 50 and 49. The former frees the lower ends of the magazine-passages which have been left open by the setting of the disk 64, allowing this set of nails to drop into the openings in the loader-block. Coincidentally with this, the contact-plate 49, by its engagement with the succeeding nails of the set, holds the remainder of the series against downward travel. Having thus supplied the loader-block with nails, the assistant carries it over the die-block, into the openings of which the nails are deposited. As soon as the projection 60 of the loader-arm leaves the surface 62, the plate 42 closes the passages in use, while the plate 49 frees them for the descent of the remainder of the nails. If the nail-supplying labor of the assistant is interfered with, he still has a reserve of three nails for the entire set to draw upon, so that this number of heels may be attached before any more nails are introduced into the magazine. On the other hand, if he has, at times, an opportunity to supply more than the one set of nails, he may do so up to the capacity of the magazine.

Having described my invention, what I claim as new and desire to secure by Letters Patent of the United States is:

1. In a magazine for mailing machines, a

member having substantially vertical passages constructed and arranged to hold nails supported in series one upon another, and means for controlling the successive delivery from the lower end of each series.

2. In a magazine for nailing machines, a member having substantially vertical passages constructed and arranged to hold nails supported in series one upon another, a movable support contacting with the lowest nail of each series, and means for retaining the succeeding nail of each series upon movement of the support.

3. In a magazine for nailing machines, a member having substantially vertical passages constructed and arranged to hold nails supported in series one upon another, a movable support contacting with the lowest nail of each series, and means for retaining the succeeding nail of each series upon movement of the support, said supporting and retaining means being movable together.

4. In a magazine for nailing machines, a member having substantially vertical passages constructed and arranged to hold nails supported in series one upon another, a movable support contacting with the lowest nail of each series, means for retaining the succeeding nail of each series upon movement of the support, and means for holding the support to normally close the passages and holding the retaining means ineffective.

5. In a magazine for nailing machines, a member having substantially vertical passages constructed and arranged to hold nails supported in series one upon another, a movable support contacting with the lowest nail of each series, means for retaining the succeeding nail of each series upon movement of the support, means for holding the support to normally close the passages and holding the retaining means ineffective, and means for moving the support to free the passages and moving the retaining means into contact with the next to the lowest nail in each passage.

6. In a magazine for nailing machines, a member having nail-holding passages arranged in a plurality of sets each constructed to contain a series of nails for successive delivery, and means constructed and arranged to permit the selective delivery of the nails from any one of the sets.

7. In a magazine for nailing machines, a member having nail-holding passages arranged in a plurality of sets each constructed to contain a series of nails for successive delivery, and a controlling member co-operating with the holding member, said controlling member containing sets of openings corresponding to the passages in the holding member, the members being arranged for relative movement to bring one or another of the sets of openings and the passages into registration.

8. In a magazine for nailing machines, a member having nail-holding passages arranged in a plurality of sets each constructed to contain a series of nails for successive delivery, and controlling members co-operating with opposite extremities of the passages in the holding member and containing sets of openings corresponding to the sets of passages, the members being arranged for relative movement to bring one or another of the sets of openings and passages into registration.

9. In a magazine for nailing machines, a member having substantially vertical nail-holding passages arranged in a plurality of sets each constructed to hold a series of nails for successive delivery, and a controlling member mounted to move adjacent to one extremity of the passages and having sets of openings corresponding to the passages.

10. In a magazine for nailing machines, a member having substantially vertical nail-holding passages arranged in a plurality of sets each constructed to hold a series of nails for successive delivery, and controlling means mounted to move adjacent to the lower and upper ends of the passages and having sets of openings corresponding to the passages.

11. In a magazine for nailing machines, a member having nail-holding passages arranged in a plurality of sets each constructed to contain a series of nails for successive delivery, a controlling member co-operating with the holding member, said controlling member containing sets of openings corresponding to the passages in the holding member, the members being arranged for relative movement to bring one or another of the sets of openings and the passages into registration, and means for controlling the delivery of nails from the holding member for any one of the selected sets.

12. In a magazine for nailing machines, a member having nail-holding passages arranged in a plurality of sets each constructed to contain a series of nails for successive delivery, controlling means arranged to be positioned to permit the delivery of nails from any one of the sets, and means for preventing interference of the nails with the controlling means.

13. In a magazine for nailing machines, a holder arranged for the delivery of nails in differently disposed sets, movable means for selecting the particular set of nails to be delivered, and means for determining the position of the selecting means, said position-determining means acting to control the movement of nails in the passages.

14. In a magazine for nailing machines, a holder arranged for the delivery of nails in differently disposed sets, movable means for selecting the particular set of nails to be delivered, and means for determining the

position of the selecting means, said position-determining means being movable to engage the nails in the holder.

15. In a magazine for nailing machines, a holder arranged for the delivery of nails in differently disposed sets, movable means for selecting the particular set of nails to be delivered, means for determining the position of the selecting means, said position-determining means being movable to engage the nails in the holder, and means for securing the position-determining means in its nail-engaging relation.

16. In a magazine for nailing machines, a block provided with passages each arranged to hold a series of nails end to end and being of transverse dimensions allowing the travel through them of the nails in single series only, and means for controlling the successive delivery of the terminal nails of the series.

17. In a magazine for nailing machines, a block provided with passages each arranged to hold a series of nails end to end and being of transverse dimensions allowing the travel through them of the nails in single series only, and a plate mounted at an extremity of the block and having openings movable into registration with the passages.

18. In a magazine for nailing machines, a block provided with nail-holding passages of transverse dimensions allowing the travel through them of the nails in single series only, a plate mounted at an extremity of the block and having openings movable into registration with the passages to effect delivery therefrom, and means for retaining the nails succeeding those delivered.

19. In a magazine for nailing machines, a block provided with nail-holding passages of transverse dimensions allowing the travel through them of the nails in single series only, a plate mounted at an extremity of the block and having openings movable into registration with the passages, and a plate movable into the passages between their extremities.

20. In a magazine for nailing machines, a block provided with nail-holding passages of transverse dimensions allowing the travel through them of the nails in single series only, a plate mounted at an extremity of the block and having openings movable into registration with the passages, and a plate movable into the passages between their extremities, the two plates being connected to move together.

21. In a magazine for nailing machines, a block provided with nail-holding passages of transverse dimensions allowing the travel through them of the nails in single series only, a plate mounted at an extremity of the block and having openings movable into registration with the passages, a plate

movable into the passages between their extremities, and a spring acting to cause the first-mentioned plate to normally close the passages and to hold the other plate out of engagement with the nails.

22. In a magazine for nailing machines, a block having sets of passages each constructed to hold a series of nails for successive delivery, each set of passages corresponding to a particular nailing design, and a plate movable upon the block and having sets of openings corresponding to the sets of passages and which may be brought into respective registration therewith.

23. In a magazine for nailing machines, a block having sets of passages each constructed to hold a series of nails for successive delivery, each set of passages corresponding to a particular nailing design, and plates movable upon the block at opposite ends of the passages and having sets of openings corresponding to the sets of passages and which may be brought into respective registration therewith.

24. In a magazine for nailing machines, a block having sets of passages each constructed to hold a series of nails for successive delivery, each set of passages corresponding to a particular nailing design, a plate movable upon the block and having sets of openings corresponding to the sets of passages and which may be brought into respective registration therewith, and a latch for holding the plate in any one of its registering positions, said latch having a portion contacting with the nails in the passages.

25. In a nailing machine, means for supporting nails in a position for driving, transferring means delivering to the nail-supporting means, a magazine having a passage arranged to contain nails in a series supported one upon another, said passage being open at the top to permit the introduction of said nails, and means for controlling the successive delivery of nails from the lower end of the series in the magazine to the transferring means.

26. In a nailing machine, means for supporting nails in a position for driving, transferring means delivering to the nail-supporting means, a magazine having a passage arranged to contain nails in a series supported one upon another, said passage being open at the top to permit the introduction of said nails, and means controlled by the transferring means for successively delivering nails from the lower end of the series in the magazine to the transferring means.

27. In a nailing machine, means for supporting nails in a position for driving, transferring means delivering to the nail-supporting means, a magazine having a passage arranged to contain nails in a series

70

75

80

85

90

95

100

105

110

115

120

125

130

supported one upon another, said passage being open at the top to permit the introduction of said nails, a movable support for the lowest nail of the series, and means for retaining the succeeding nail upon movement of the support.

28. In a nailing machine, means for supporting nails in a position for driving, transferring means delivering to the nail-supporting means, a magazine having a passage arranged to contain nails in a series supported one upon another, said passage being open at the top to permit the introduction of said nails, a movable support for the lowest nail of the series, and means movable with the support for retaining the succeeding nail upon movement of the support.

29. In a nailing machine, means for supporting nails in a position for driving, transferring means delivering to the nail-supporting means, a magazine having a passage arranged to contain nails in a series supported one upon another, said passage being open at the top to permit the introduction of said nails, a movable support for the lowest nail of the series, and means movable with the support under the influence of the transferring means for retaining the succeeding nail upon movement of the support.

30. In a nailing machine, means for supporting nails in a position for driving, transferring means delivering to the supporting means, a magazine for supplying nails to the transferring means and having passages for each of a plurality of nailing designs for which the supporting means is adapted, each passage being arranged to contain nails in a series, and means arranged to limit the passages effective in the supply to the transferring means to one or another of the nailing designs.

31. In a nailing machine, means for supporting nails in a position for driving, transferring means delivering to the supporting means, a magazine for supplying nails to the transferring means and having

passages for each of a plurality of nailing designs for which the supporting means is adapted, each passage being arranged to contain nails in a series and being open at the top to permit the introduction of said nails, means for controlling the successive delivery of nails from the lower ends of each series, and means arranged to limit the passages effective in the supply to the transferring means to one or another of the nailing designs.

32. In a nailing machine, means for supporting nails in a position for driving, transferring means delivering to the supporting means, a magazine for supplying nails to the transferring means and having passages for each of a plurality of nailing designs for which the supporting means is adapted, each passage being arranged to contain nails in a series and being open at the top to permit the introduction of said nails, means for controlling the successive delivery of nails from the lower end of each series, means arranged to limit the passages effective in the supply to the transferring means to one or another of the nailing designs and arranged to be set to render effective the passages corresponding to the particular nailing design, and means for determining the setting of the controlling means, said setting-determining means contacting with the nails in the passages.

33. In a nailing machine, means for supporting nails in a position for driving, transferring means delivering to the supporting means, a magazine for supplying nails to the transferring means and having sets of passages, each set corresponding to one of a plurality of nailing designs for which the supporting means is adapted, each passage being arranged to contain nails in a series, and means movable to close the lower extremities of all passages except those for some one of the nailing designs.

In testimony whereof I have signed my name to this specification.

ELMER R. POPE.