



US00RE42579E

(19) **United States**  
(12) **Reissued Patent**  
**Bhaskar et al.**

(10) **Patent Number:** **US RE42,579 E**  
(45) **Date of Reissued Patent:** **Jul. 26, 2011**

(54) **VIRTUAL MACHINE PROGRAMMING SYSTEM**  
(75) Inventors: **Kasi S. Bhaskar**, Seattle, WA (US);  
**James K. Peckol**, Edmonds, WA (US)  
(73) Assignee: **National Instruments Corporation**,  
Austin, TX (US)

4,298,955 A 11/1981 Munday et al. .... 364/900  
4,315,315 A \* 2/1982 Kosiakoff ..... 717/109  
4,455,619 A \* 6/1984 Masui et al. .... 345/530  
4,497,033 A 1/1985 Hernandez et al. .... 364/900  
4,499,549 A 2/1985 Bartlett ..... 364/900  
4,546,435 A 10/1985 Herbert et al. .... 364/308  
4,570,217 A 2/1986 Allen et al.

(Continued)

(21) Appl. No.: **11/443,553**  
(22) Filed: **May 30, 2006**

**Related U.S. Patent Documents**

Reissue of:

(64) Patent No.: **5,479,643**  
Issued: **Dec. 26, 1995**  
Appl. No.: **07/750,772**  
Filed: **Aug. 22, 1991**

U.S. Applications:

(60) Continuation of application No. 07/238,145, filed on Aug. 30, 1988, now abandoned, which is a division of application No. 06/798,931, filed on Nov. 18, 1985, now Pat. No. 4,849,880.

(51) **Int. Cl.**  
**G06F 9/44** (2006.01)  
**G06F 3/048** (2006.01)  
**G05B 15/00** (2006.01)

(52) **U.S. Cl.** ..... **717/109**; 717/105; 717/107; 717/113;  
717/124; 715/771; 715/859; 700/17; 700/83

(58) **Field of Classification Search** ..... None  
See application file for complete search history.

(56) **References Cited**

**U.S. PATENT DOCUMENTS**

4,064,394 A 12/1977 Allen ..... 364/107  
4,152,760 A 5/1979 Freitas et al. .... 364/900  
4,245,318 A 1/1981 Eckart et al. .... 364/481

**OTHER PUBLICATIONS**

Bhaskar, K.S. et al., "Virtual Instruments: Object-Oriented Program Synthesis," Proceedings of the Conference on Object-Oriented Programming Systems, Languages and Applications, Sep. 1986, pp. 303-314.\*

(Continued)

*Primary Examiner* — Michael J Yigdall  
(74) *Attorney, Agent, or Firm* — Meyertons Hood Kivlin Kowert & Goetzel, P.C.; Jeffrey C. Hood; Dean M. Munyon

(57) **ABSTRACT**

A system for programming a computer provides a set of software-based virtual machines each for instructing a computer to carry out a selected operation. Each virtual machine is represented by a virtual front panel displayed on a screen and each virtual front panel graphically displays operator controllable values of input and output parameters utilized by the virtual machine it represents. The system is adapted to synthesize a new virtual machine for instructing the computer to perform a sequence of operations wherein each operation is carried out by the computer according to the instructions of an operator selected one of the existing virtual machines. The system also creates a new virtual front panel for displaying input and output parameters associated with the new virtual machine. The system permits the operator to program the computer by directing synthesis of a hierarchy of virtual machines.

**48 Claims, 8 Drawing Sheets**

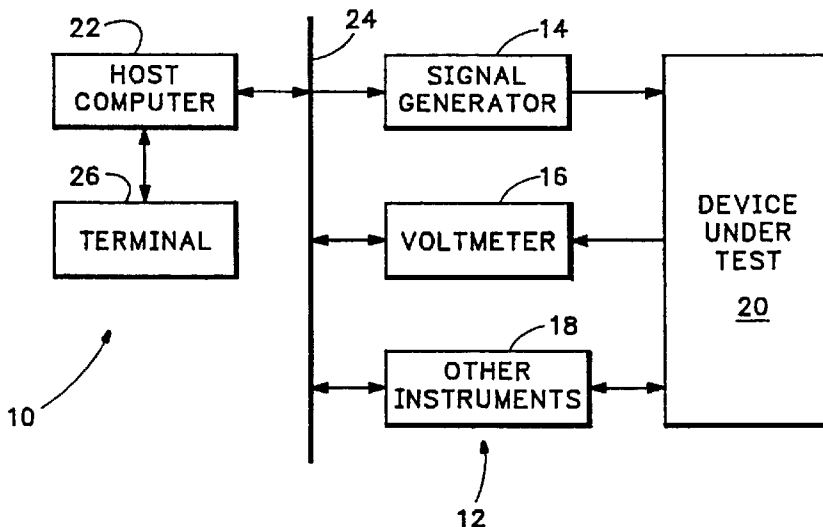

## U.S. PATENT DOCUMENTS

4,586,035 A	4/1986	Baker et al. ....	340/712
4,628,444 A	12/1986	Nozawa et al. ....	364/900
4,635,183 A	1/1987	Isobe et al. ....	364/188
4,636,934 A	1/1987	Schwendemann et al. ....	364/132
4,642,790 A	2/1987	Minshull et al. ....	364/900
4,656,603 A *	4/1987	Dunn .....	715/835
4,663,704 A *	5/1987	Jones et al. ....	700/83
4,674,053 A	6/1987	Bannai et al. ....	364/146
4,677,587 A	6/1987	Zemany, Jr. ....	364/900
4,679,137 A *	7/1987	Lane et al. ....	700/83
4,688,167 A	8/1987	Agarwal .....	364/200
4,695,968 A	9/1987	Sullivan, II et al. ....	364/578
4,736,340 A *	4/1988	Desserrieres et al. ....	715/762
4,745,543 A	5/1988	Michener et al. ....	364/146
4,811,205 A	3/1989	Normington et al. ....	364/900
4,813,013 A *	3/1989	Dunn .....	715/763
4,816,988 A	3/1989	Yamanaka .....	364/188
4,868,785 A *	9/1989	Jordan et al. ....	345/440
4,901,221 A *	2/1990	Kodosky et al. ....	715/771
4,914,568 A *	4/1990	Kodosky et al. ....	715/763
4,967,381 A *	10/1990	Lane et al. ....	702/81
5,301,336 A *	4/1994	Kodosky et al. ....	715/846

## OTHER PUBLICATIONS

Third Amended Compliant; *SoftWIRE Technology, LLC and Measurement Computing Corporation vs. National Instruments Corporation* (Civil Action No. 03-10107REK); Nov. 6, 2003; 11 pages.

Answer to Third Amended Complaint; *SoftWIRE Technology, LLC and Measurement Computing Corporation vs. National Instruments Corporation* (Civil Action No. 03-10107REK); Nov. 21, 2003; 14 pages.

Defendant National Instruments' Second Supplemental Responses to Plaintiff SoftWIRE Technology's Fourth Set of Interrogatories [Nos. 11-12]; *SoftWIRE Technology, LLC and Measurement Computing Corporation vs. National Instruments Corporation* (Civil Action No. 03-10107REK); Sep. 30, 2004; 68 pages.

Stipulated Dismissal with Prejudice; *SoftWIRE Technology, LLC and Measurement Computing Corporation vs. National Instruments Corporation* (Civil Action No. 03-10107REK); Apr. 29, 2005; 5 pages.

T.K. Barnaby; "An Exploration of the Virtual Instrumentation Concept"; Thesis Presented to the University of Wales; Nov. 1983; 227 pages.

Terry Kenneth Barnaby; "The Virtual Instrument Workstation"; Thesis Presented to the University of Wales; Dec. 1987; 307 pages.

Carla M. Wong and Richard W. Crawford; "Application of Artificial Intelligence to Triple Quadrupole Mass Spectrometry (TQMS)"; Institute of Electrical and Electronics Engineers; Oct. 1983; 11 pages.

Michael N. Granieri, William Keefe, and Thomas McNamee; "An Approach to an Open-Architecture Functional Testing System"; IEEE; 1984; 8 pages.

"Preliminary Modvue Applications Design Guide"; 1982; 80 pages.

David Canfield Smith; "Pygmalion: A Creative Programming Environment"; Dissertation Presented to Stanford University; May 1975; 244 pages.

Alan Boring; "ThingLab—A Constraint-Oriented Simulation Laboratory"; Xerox; Jul. 1979; 107 pages.

Thomas S. McNamee and John J. Woodfine; "Instrument-Based Test Generation a Cost-Effective Program Development Tool"; ManTech International Corporation; 1983; 5 pages.

Douglas R. Haroldsen; "Software Package Lets PC Control Instruments with a Touch"; Electronic Design, Oct. 31, 1984; 9 pages.

Michael A. Catalano and Michael J. Charland; "The Use of Touchsensitive Video Displays in on Line Control Systems"; Canberra Industries, Meriden, CT, IECON 1983; 7 pages.

PCIL. Process Control and Instrumentation Ltd., formed in 1981, articles dated 1984; 8 pages.

"Control and Instrumentation Magazine"; Feb. 1984; 4 pages.

Kazuo Yano, Tadashi Nishijima, Katsuhisa Yamaguchi, and Ichiro Akasaki; "Microcomputer-Based Programmable Controller Systems for Industrial Application"; Toshiba Corporation; IEEE 1983; 7 pages.

Timothy J. Miller; "Bit-Mapped Graphics Editor Simplifies High Resolution Display Building"; Control Engineering; Apr. 1984; 2 pages.

"The Knowledge Engineering Environment—An IntelliCorp Technical Article"; 1984; 26 pages.

Thomas P. Kohler; An Application Development System for Expert Systems; Intelligent Systems, and Software, Jan. 1984; 17 pages.

Mark Stefik and Daniel G. Bobrow; "Object-Oriented Programming: Themes and Variations"; Intelligent Systems Laboratory; The AI Magazine, 1984; 23 pages.

"Activelimages Package—The First KEE System PowerPak"; IntelliCorp, 1984; 4 pages.

Richard Fikes and Tom Kehler; "The Role of Frame-Based Representation in Reasoning"; Communications of the ACM, vol. 28, No. 9, Sep. 1985; 17 pages.

Carla M. Wong; Expert Systems Technology Applied to Instrument Operation and Data Acquisition of a Triple Quadrupole Mass Spectrometer (TQMS); National Computer Conference at Las Vegas, Nevada; Jul. 9-12, 1984; 60 pages.

Carla M. Wong; "Expert Systems for the Laboratory: Triple Quadrupole Mass Spectrometry (TQMS) (A Capsule Report on 'Expert System' for A/C Interface)"; Mar. 1984; 13 pages.

Mark Stefik, Daniel G. Bobrow, Sanjay Mittal, and Lynn Conway; "Knowledge Programming in Loops: Report on an Experimental Course"; The AI Magazine, Fall 1983; 22 pages.

Daniel G. Bobrow and Mark Stefik; "The Loops Manual (Preliminary Version)"; Xerox Corporation, 1983; 128 pages.

Alan Boring; "The Programming Language Aspects of ThingLab, a Constraint-Oriented Simulation Laboratory"; Xerox Palo Alto Research Center; ACM Oct. 1981; 70 pages.

D. Dustin Henderson, Jr.; The Trillium User Interface Design Environment; Intelligent Systems Laboratory Xerox Palo Alto Research Center; CHI'86 Proceedings, 1986; 7 pages.

John L. Hedrick and Evan L. Pagedler; "Effective Operation System Characterization with an Interactive Colorgraphics Operator Console"; Fisher Controls Company, ISA Advances in Instrumentation, Oct. 20-23, 1980; 14 pages.

W. Buxton, M.R. Lamb, D. Sherman, and K.C. Smith; "Towards a Comprehensive User Interface Management System"; Computer Graphics, vol. 17, No. 3; Jul. 1983; 8 pages.

"Supersmart Equipment—Software for Computer-Based Instruments Brings Users a Plethora of Benefits"; IEEE Spectrum, Jan. 1983; 5 pages.

William F. Finzer and Laura Gould; "Programming by Rehearsal"; Byte, Jul. 1984; 17 pages.

Arnold Miller; "The Programmable Controller Based Distributed Control System"; ISA Advanced in Instrumentation, Oct. 22-25, 1984; 15 pages.

Aragam R. Nagesh, Richard S. Shirley and Maureen E. Gordon; Rapid Prototyping for the Human/ Process Interface; ISA Advances in Instrumentation, Oct. 22-25, 1984; 14 pages.

Shin-Ichi Takigishi, Hiroshi Yamada, and Harry Wilson; "User-Oriented Flexible Operator Station for Distributed Process Control Systems"; ISA Advances in Instrumentation, Oct. 22-25, 1984; 14 pages.

Steven K. Gregory; "Interactive Television for Control Systems"; ISA Advances in Instrumentation, Oct. 20-23, 1980; 11 pages.

Kenneth D. Forbus; "An Interactive Laboratory for Teaching Control System Concepts"; Report No. 5511, Jan. 1984; 41 pages.

Michael Williams, James Hollan, and Albert Stevens; "An Overview of Steamer: An Advanced Computer-Assisted Instruction System for Propulsion Engineering"; Psychonomic Society, 1981; 6 pages.

James Hollan, Edwin Hutchins, Mark Rosenstein, and Louis Weitzman; "Tools for Graphical Interface Design"; Proceedings of a Symposium Sponsored by the Metropolitan Chapter of the Human Factors Society, Nov. 15, 1984; 17 pages.

Michael D. Williams, James D. Hollan, and Albert L. Stevens; "Human Reasoning About a Simple Physical System"; Chapter 7; 1981; 23 pages.

James D. Hollan, Edwin L. Hutchins, and Louis Weitzman; "Steamer: An Interactive Inspectable Simulation-Based Training System"; The AI Magazine, Summer 1984; 13 pages.

Albert Stevens, Bruce Roberts, and Larry Stead; "The Use of a Sophisticated Graphics Interface in Computer-Assisted Instruction"; IEEE CH&A, Mar./Apr. 1983; 12 pages.

James Hollan, Albert Stevens, and Michael Williams; "Steamer: An Advanced Computer-Assisted Instruction System for Propulsion Engineering"; 1980; 5 pages.

Robert V. Rubin; "Language Constructs for Programming by Example"; Department of Computer Science, Brown University, 1986; 12 pages.

Brad A. Myers; "Visual Programming, Programming by Example, and Program Visualization: A Taxonomy"; Dynamic Graphics Project at University of Toronto, Apr. 1986; 8 pages.

\* cited by examiner

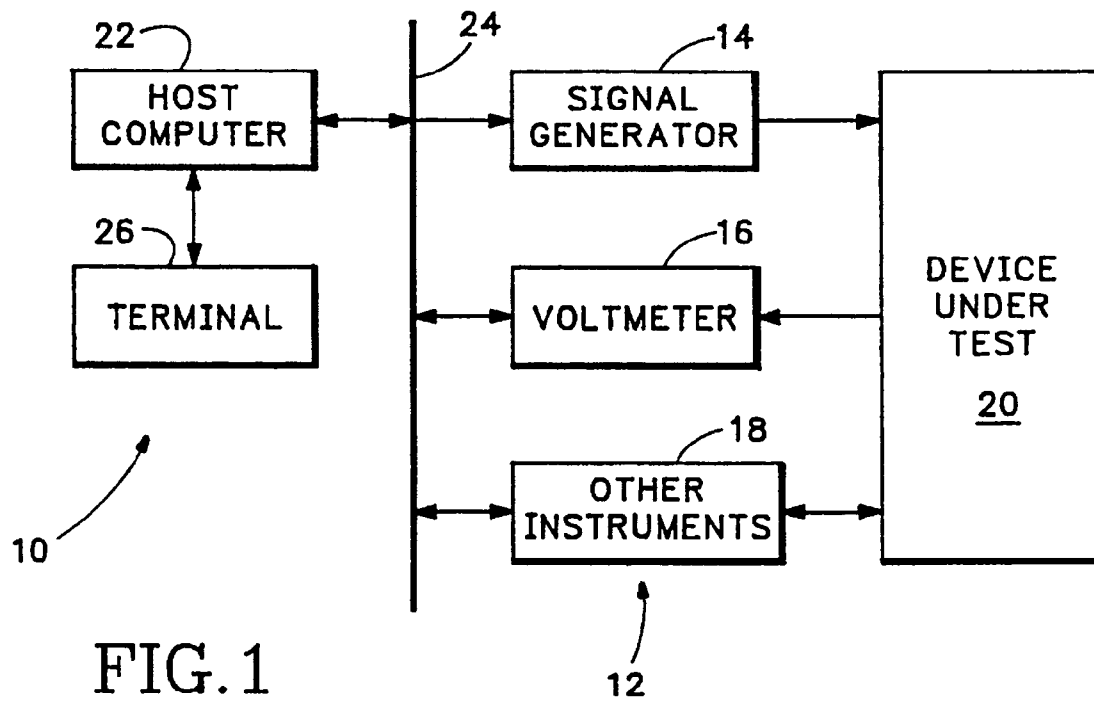

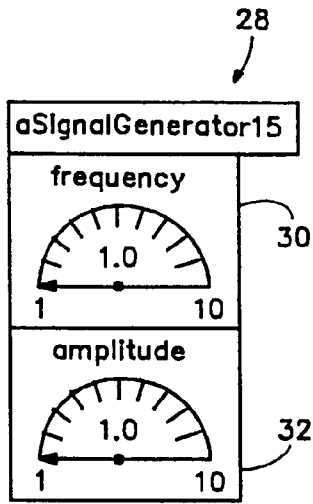

FIG. 2A

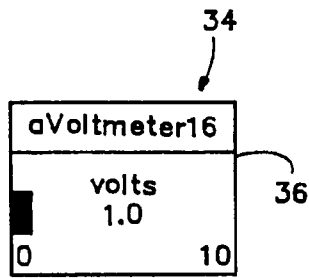

FIG. 2B

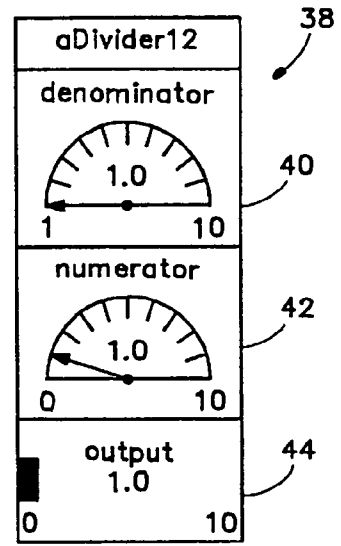

FIG. 2C

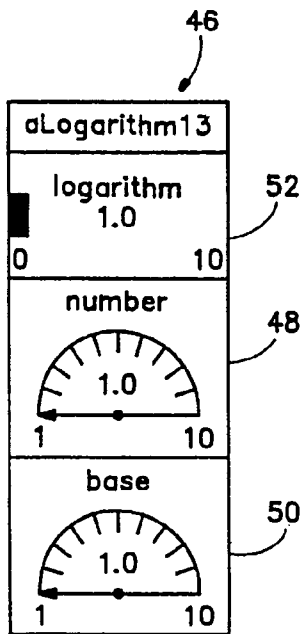

FIG. 2D

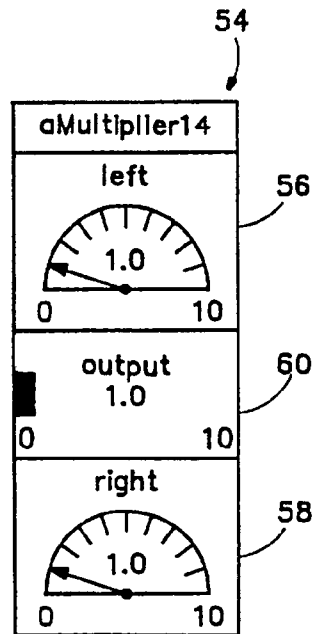

FIG. 2E

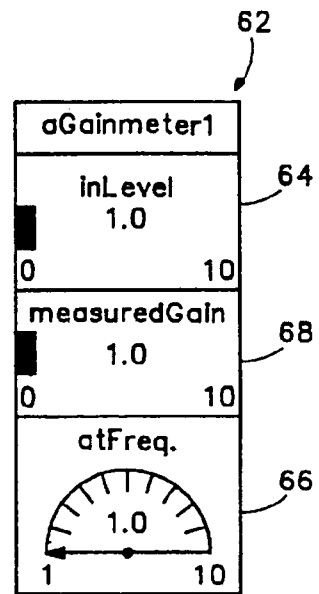

FIG. 2F

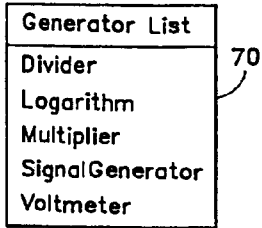

FIG. 3A

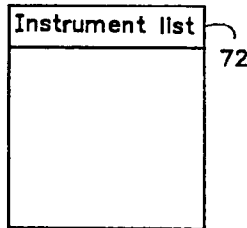

FIG. 3B

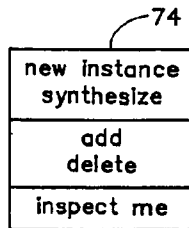

FIG. 3C

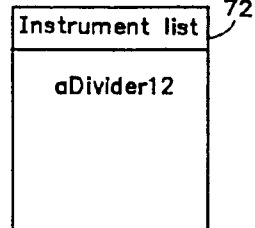

FIG. 3D

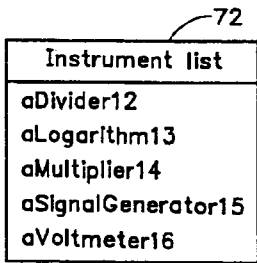

FIG. 3E

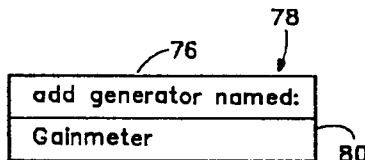

FIG. 3F

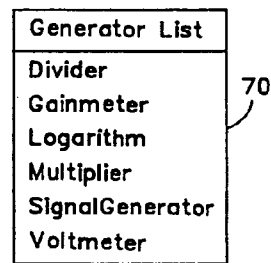

FIG. 3G

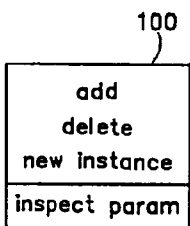

FIG. 3H

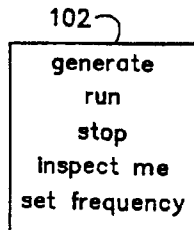

FIG. 3I

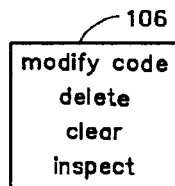

FIG. 3J

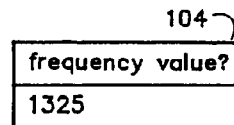

FIG. 3K

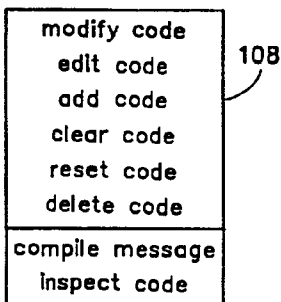

FIG. 3L

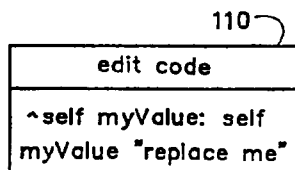

FIG. 3M

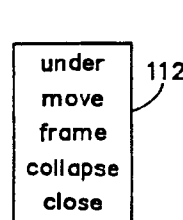

FIG. 3N

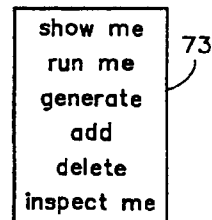

FIG. 3P

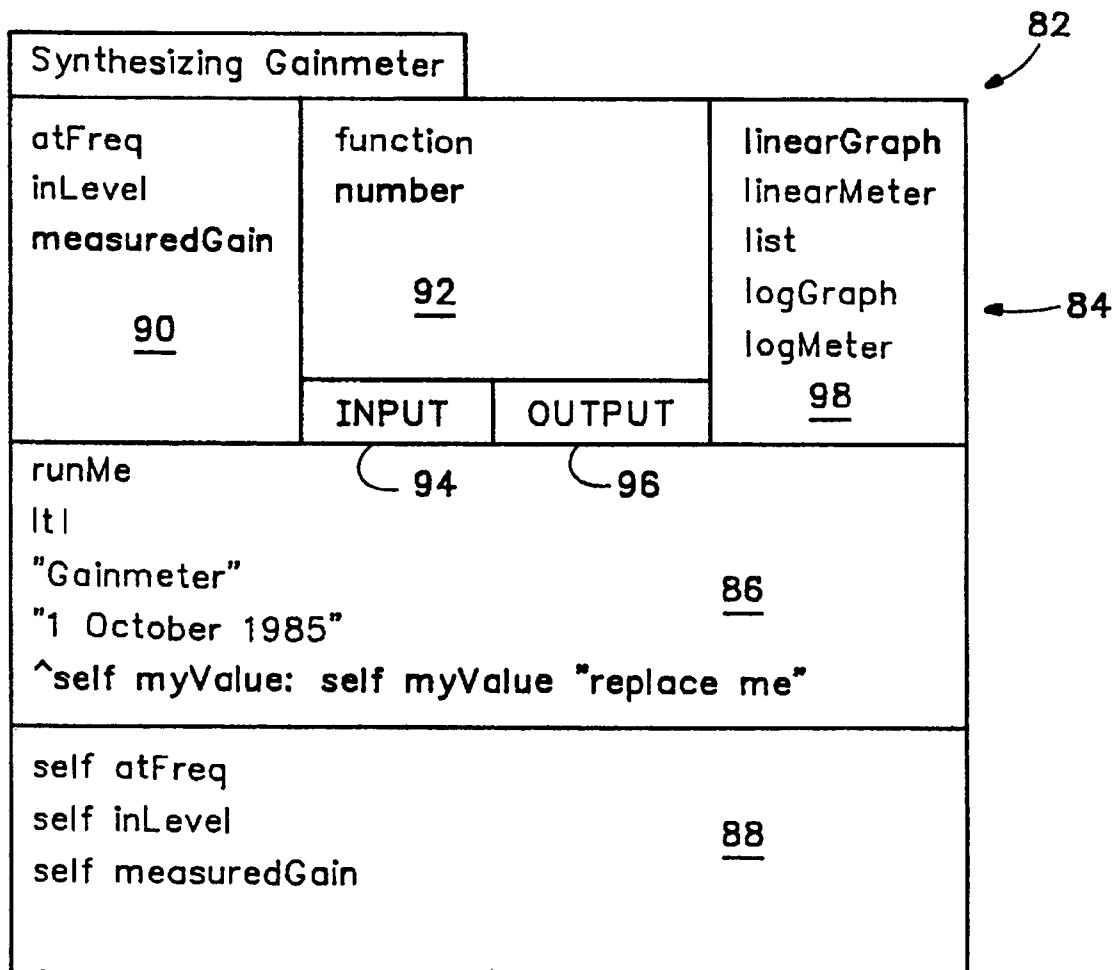

FIG. 4



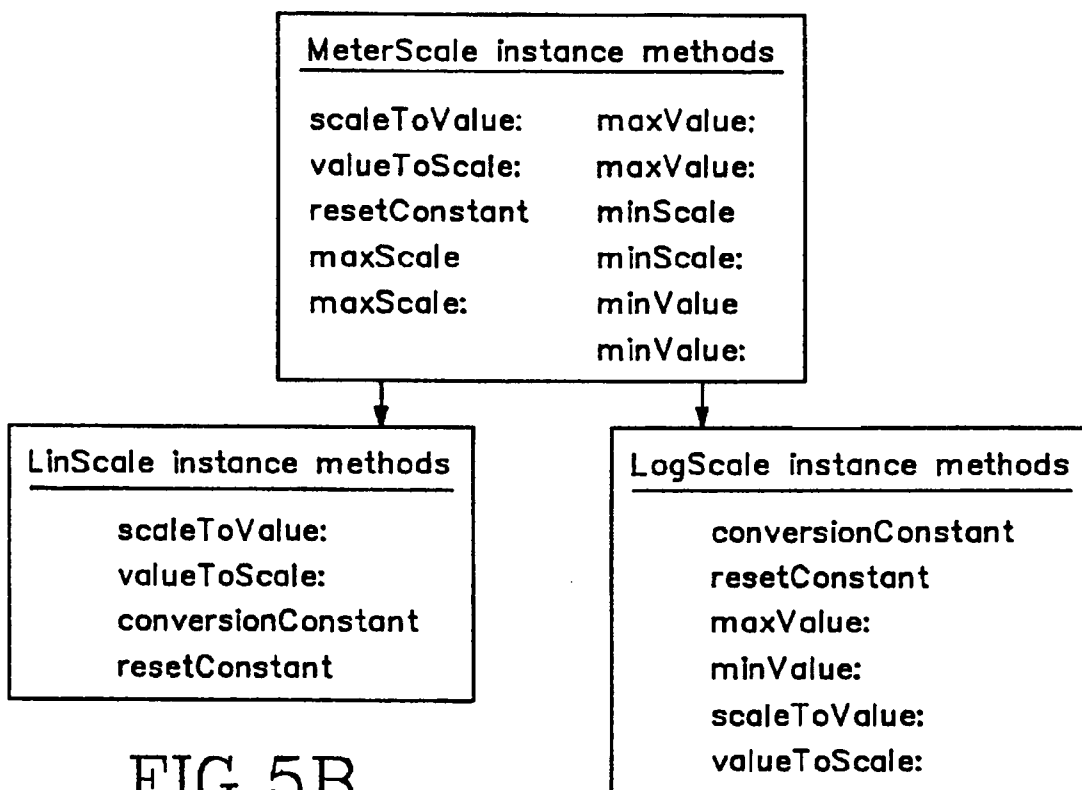

FIG. 5B

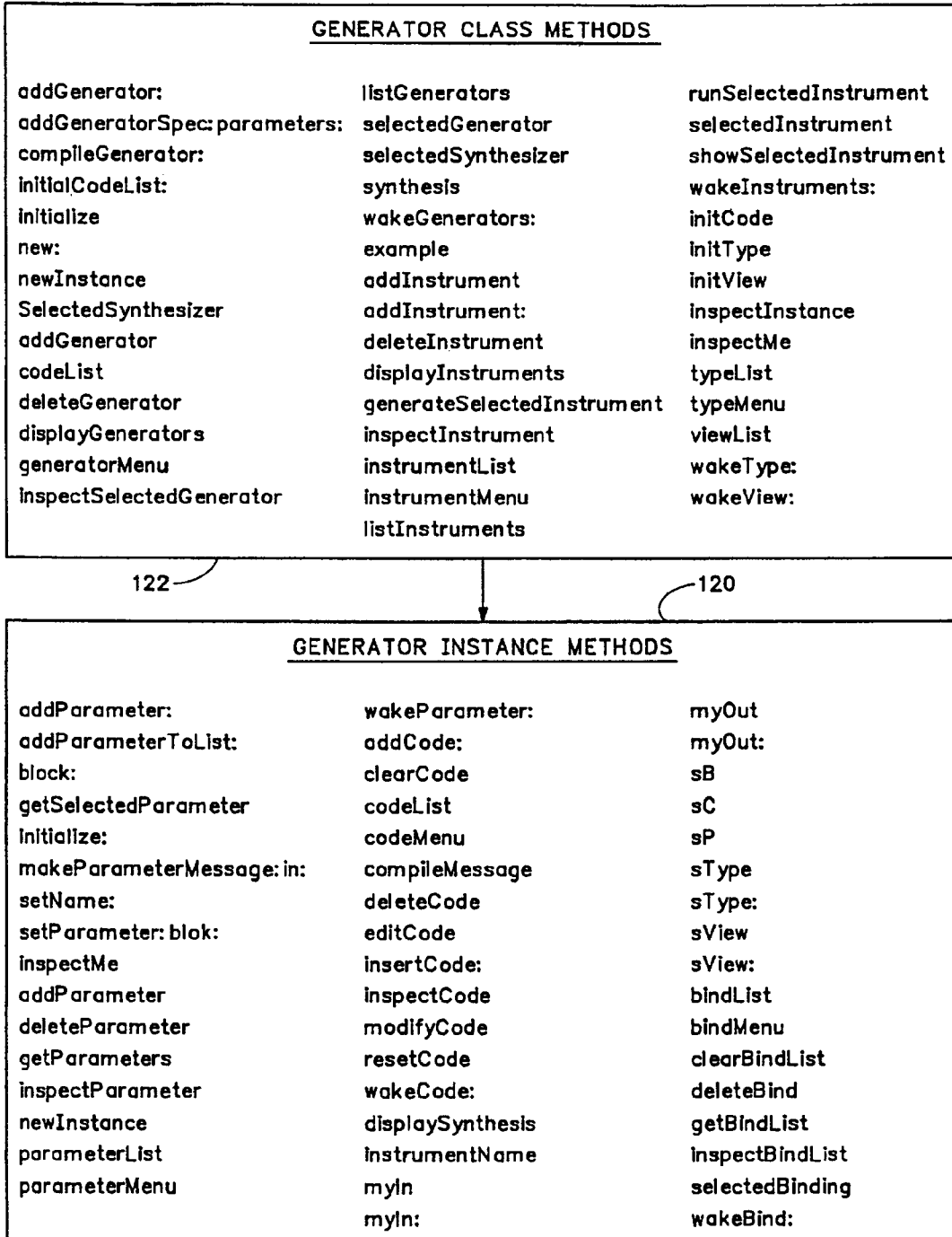

FIG. 6

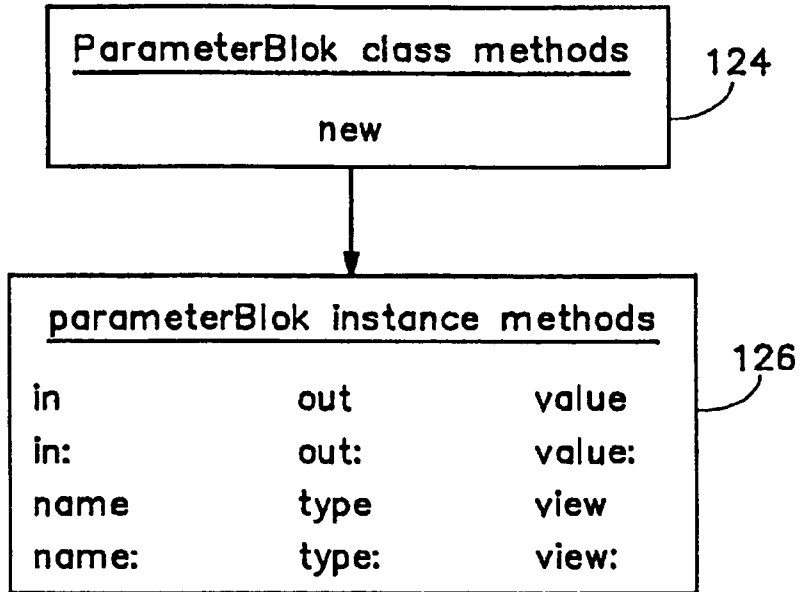

FIG. 7

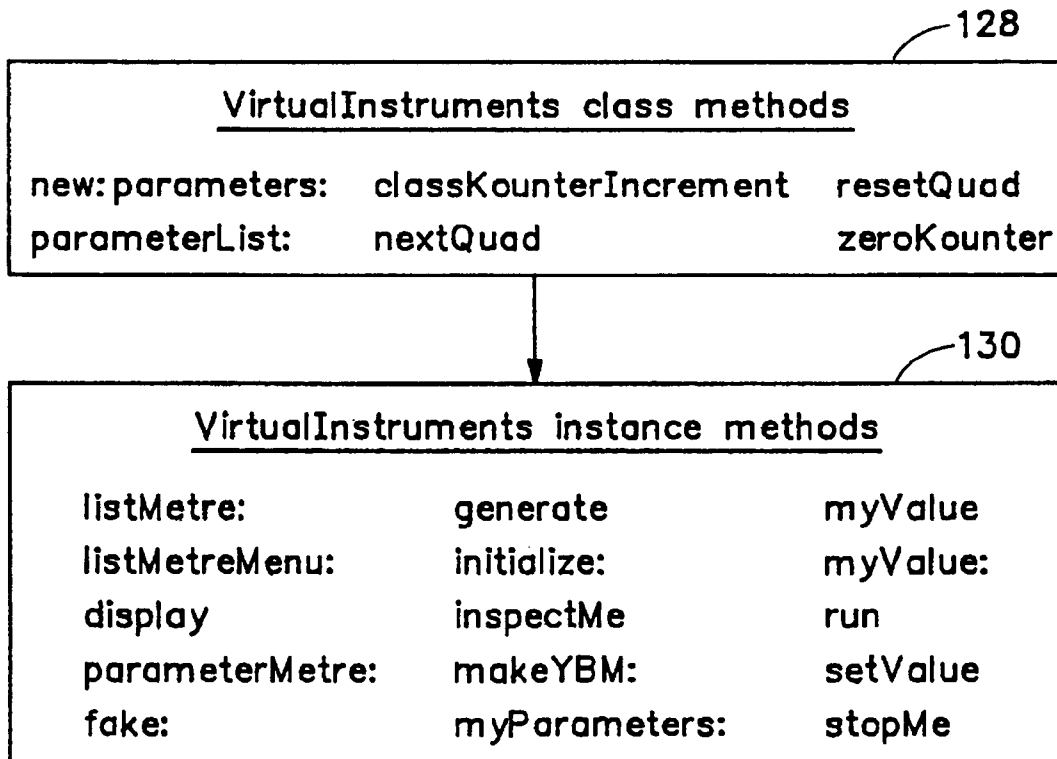

FIG. 8

## VIRTUAL MACHINE PROGRAMMING SYSTEM

**Matter enclosed in heavy brackets [ ] appears in the original patent but forms no part of this reissue specification; matter printed in italics indicates the additions made by reissue.**

This is a continuation of application Ser. No. 07/238,145 filed Aug. 30, 1988, and now abandoned, which is a divisional application of Ser. No. 06/798,931 filed Nov. 18, 1985, now U.S. Pat. No. 4,849,880 issued Jul. 18, 1989.

### BACKGROUND OF THE INVENTION

The present invention relates in general to programming of computer systems and more particularly to a method and apparatus for developing applications software.

The number of applications for computers has grown remarkably in the last few years and so too has the number of persons skilled in the art of computer programming. Nonetheless computer literacy is not universal and in any case the programming of any new system is usually time consuming. One category of a programmable system involves computer controlled combinations of test instruments adapted to provide a common result. Microcomputers have been incorporated into the design of many electronic test instruments such as multimeters, signal generators, logic analyzers, digitizers and the like wherein the microcomputers typically control instrument settings, data storage and display, and often provide communication with a host computer through interconnecting buses. The host computer may be programmed to supply instructions to the microprocessor in each instrument for controlling the operation of the individual instruments in performing selected tests, while also acquiring data from the instruments, performing calculations based on the acquired data, and displaying the results. Once computer software is developed for various tests to be performed the computer-based instrument system greatly reduces the labor required inasmuch as an operator does not then have to manually adjust the settings of the instruments before or during such test and does not have to manually assemble or process the data acquired. However, the major drawback to such computer-based instrument systems relates to the need for development of separate host computer software for each combination of tests. Testing is described by way of example and it is understood the problems associated with assembling of other combination systems may be similarly addressed. What is needed is a method and apparatus for permitting persons not skilled in the art of computer programming to easily develop easily used computer applications software.

### SUMMARY OF THE INVENTION

According to one aspect of the present invention, a computer programming system provides a set of software-based "virtual machines" each for receiving input parameters and for producing output parameters related to the input data in a selected manner. Each virtual machine is suitably represented by a corresponding "virtual front panel" comprising a graphical display or other means for representing its input and output data. The system permits an operator to adjust the values of input parameters displayed by the virtual front panel, by manipulating a cursor or the like, and allows the operator to command the machine to "run" (i.e., to produce

and display its output parameters based on the current input parameters) by selecting a command from a displayed menu or other input. The virtual machine front panel provides a graphical representation of underlying virtual machine software in a manner easily understood by an operator and facilitates communication between software and operator.

According to another aspect of the present invention, the operator can define a "synthesized virtual machine" for performing a selected sequence of operations, the operator defining each operation of the sequence by selecting a pre-existing virtual machine capable of performing such operation. The operator also names the input and output parameters of the virtual machine and specifies where the input parameters required by each operation of the sequence are to be obtained. The programming system of the present invention then generates and stores computer code necessary to implement the synthesized virtual machine, including an associated virtual front panel according to the operator's specification, thereby permitting an operator to create applications software without actually writing it. Once the software for a virtual machine has been synthesized, the operator may create instances and for each may adjust the input parameters of the synthesized virtual machine and command it to run in the same manner as any other virtual machine.

According to a further aspect of the invention, the operator may synthesize additional "higher order" virtual machines wherein one or more of a sequence of operations is carried out by previously synthesized virtual machines. In such fashion the operator may create a hierarchy of synthesized virtual machines, each higher order virtual machine employing lower order machines in performing its function. This aspect of the invention permits an operator to create highly complex applications software in a structured manner wherein each separate element of the software comprises a virtual machine which can be independently tested and modified, thereby simplifying the process of developing and debugging applications software.

According to still another aspect of the invention in a preferred embodiment thereof, a host computer is connected through a bus to a set of microcomputer-based instruments such as voltmeters, signal generators and the like, each adapted for performing a selected test or other function. Each instrument is represented by the host computer as a corresponding virtual "instrument" or machine including means to transmit input parameters to the corresponding instrument and to receive output parameters therefrom, the input and output parameters being displayed on a corresponding virtual front panel. Selected host computer operations such as addition, multiplication, and the like, are also carried out by representative virtual machines. Each virtual machine is available for selection by an operator when synthesizing a higher level virtual machine so that operation of any real instrument may form a step in a sequence of operations performed by the higher level virtual machine.

Accordingly, an operator may synthesize a virtual machine to control and coordinate the operations of one or more instruments accessed by the host computer, perform computations based on the data produced by such instruments, and display the results of the computations as outputs on a virtual front panel.

It is therefore an object of the invention to provide a new and improved method and apparatus for organizing computer operation.

It is another object of the invention to provide a new and improved method and apparatus for developing and structuring computer applications software.

It is a further object of the invention to provide a new and improved method and apparatus for programming a computer-based instrument system.

The subject matter of the present invention is particularly pointed out and distinctly claimed in the concluding portion of this specification. However, both the organization and method of operation of the present invention, together with further advantages and objects thereof, may best be understood by reference to the following description taken in connection with accompanying drawings wherein like reference characters refer to like elements.

### DRAWINGS

FIG. 1 is a block diagram of a computer-based instrument system for implementing the present invention;

FIGS. 2A-2F are views of virtual front panels for selected virtual instruments;

FIGS. 3A-3P comprise menus, lists and dialog box displays produced by the present invention;

FIG. 4 illustrates an example of a synthesizing window display according to the present invention; and

FIGS. 5-8 are charts of code listings for implementing the present invention.

### DETAILED DESCRIPTION

Referring to FIG. 1, there is depicted in block diagram form a computer-based instrument system 10 adapted to control and coordinate the operations of a plurality of computer-based instruments 12 according to the present invention. Instruments 12 include, by way of example, a signal generator 14, a voltmeter 16, and such other instruments 18 as may be useful for testing a device under test 20. Each instrument 12 includes means for receiving signals and input data for controlling its operation from a host computer 22 transmitted over a means for communication such as a bus 24 and/or means to transmit acquired data back to the host computer 22 over means 24. The system 10 also includes a terminal 26 having a display screen and input devices including a keyboard and a mouse controller or similar device for controlling the position of a cursor on the screen. The mouse is provided with three buttons: a red button for selecting objects indicated by the cursor, a blue button for opening a menu for controlling the display of a selected display window on the screen, and a yellow button for opening menus for controlling the behavior of software associated with a selected window.

According to the present invention, the host computer 22 is adapted to communicate with each instrument 12 by means of a corresponding software-based virtual instrument (i.e., virtual machine) comprising a set of computer instructions for performing a selected function and which may be graphically represented in the form of a corresponding "virtual front panel" displayed on terminal 26. The virtual front panel associated with a virtual machine suitably displays the values of any input parameters used by the machine and any output parameters produced by the virtual machine.

A virtual instrument or machine may be adapted to transmit its input parameters to the corresponding real instrument and to acquire its output parameters from the real instrument through bus 24.

Signal generator 14 suitably produces a sinewave signal having two variables, frequency and amplitude, as controlled by data provided by the host computer 12 via bus 24. Referring to FIG. 2A, there is depicted a virtual front panel 28 of a virtual instrument associated with signal generator 14. The values of the frequency and amplitude control variables, com-

prising input parameters of the virtual instrument, are graphically displayed on the screen of terminal 26 in the form of two simulated, dial-type, logarithmic scale meters 30 and 32. As indicated the signal generator 14 has a frequency range of 1 to 10 (e.g. Hertz) and an amplitude range of 1 to 10 (e.g. volts). The meter representations in the FIG. 2A display are illustrative of settings of 1.0 Hertz and 1.0 volts. The value indicated by each analog meter is also digitally displayed in the center of the meter.

Referring to FIG. 2B, there is depicted a virtual front panel 34 of a virtual instrument associated with the voltmeter 16 of FIG. 1, including a simulated linear bar graph meter display 36 representing the output value of the voltmeter. When the virtual instrument associated with the voltmeter is actuated, it acquires data from the voltmeter indicating the value of the presently measured voltage and adjusts the bar graph meter 36 to display that value. The voltmeter output value is also digitally displayed at the center of the bar graph meter.

The host computer is further adapted to perform a variety of computational or other functions (such as addition, multiplication and the like) and each such function takes the form of a corresponding virtual machine (such as an "adder", "multiplier", or the like) also graphically represented by a virtual front panel on terminal 22. For convenience, these virtual machines may also be referred to as virtual instruments. Referring to FIG. 2C, the virtual front panel 38 of a "divider" virtual machine is illustrated for dividing a "numerator" parameter by a "denominator" parameter and outputting the result. The front panel includes three simulated meters: one logarithmic scale meter 40 displays the value of the "denominator", a second linear scale meter 42 displays the value of the "numerator", and a third linear graph meter 44 displays the divided result or "output".

Referring to FIG. 2D a front panel 46 for a "logarithm" virtual machine, capable of obtaining the logarithm of any input "number" parameter number from 1 to 10 to any base from 1 to 10 (by way of example), includes a logarithmic dial meter 48 for displaying the input "number" parameter, a logarithmic dial meter 50 for displaying a selected input "base" parameter, and a linear graph meter 52 for displaying a "logarithm" parameter output. In FIG. 2E, a front panel 54 for a "multiplier" virtual machine, capable of producing an output parameter having a value equal to the product of two input parameter values, includes a linear scale meter 56 for showing the value "left" of one input value, a linear dial meter 58 for showing the value "right" of another input value, and a linear graph meter 60 "output" for showing the value of the product of the left and right input parameter values. It is apparent that many other virtual machines are possible and the foregoing are described only by way of example.

The present invention permits an operator to synthesize a higher order virtual machine for performing any selected sequence of operations, wherein each operation of the synthesized virtual machine is carried out by one or more selected pre-existing virtual machines in a given sequence. Referring to FIG. 1, and assuming that device under test 20 is, for example, an amplifier, the operator may wish to synthesize a "gainmeter" virtual instrument for determining the gain of the amplifier at some selected input voltage and frequency. To test amplifier gain, the signal generator 14 is set to produce a signal of the selected voltage and frequency, and this signal is applied to the amplifier input. The resulting amplifier output voltage is measured by voltmeter 16 and the gain G of the amplifier is computed according to the following equation:

$$G=20*\text{Log}_{10}(V2/V1).$$

[A]

where V2 is the output voltage of the amplifier measured by the voltmeter and V1 is the output voltage of the signal generator. Thus a gainmeter virtual instrument would implement an operation involving the use of a signal generator virtual instrument to produce V1, a voltmeter virtual instrument to produce V2, a divider virtual instrument (machine) to compute the ratio of V2 to V1, a logarithm virtual instrument (machine) to find the log to the constant base of the output (V2/V1) of the divider virtual instrument, and a multiplier virtual instrument (machine) to find the product of a constant (20) and the output  $\text{Log}_{10}(\text{V2/V1})$  of the logarithm virtual instrument.

Referring to FIG. 2F, a virtual front panel 62 is illustrated representing such a gainmeter virtual instrument, and includes meters 64 and 66 for displaying the values "inLevel" and "atFreq" for the voltage and frequency of the input signal applied, and a meter 68 for displaying the value "measuredGain" determined, by the synthesized gainmeter.

Software adapted to implement the preferred embodiment of the present invention is provided by way of example in the "Smalltalk-80" language. This language is described in detail in a book entitled Smalltalk-80, The Language and its Implementation, written by Adele Goldberg and David Robson and published by the Addison-Wesley Publishing Company in 1983, incorporated herein by reference. The Smalltalk-80 language treats numbers, character strings, programs, computational processes and the like as "objects" consisting of private memory for storing variables and a set of instructions ("methods") for carrying out procedures in response to messages received from other objects. All similar objects comprise an object "class" with each individual object constituting an "instance" of its class. Each different type of virtual machine implemented in computer 22 comprises a separate object class and each virtual machine within a class is an instance of a class. For example, a class of virtual machines called "Divider" may include several examples of dividers, each operating in an identical fashion but used in different applications. A class may also be "empty" in the sense that while the operation of a virtual machine for the class is defined, there are no instances of the class being used in any application.

When an operator wishes to synthesize a new virtual instrument, such as a gainmeter, he creates new instances for every existing virtual instrument (machine) needed to perform the sequence of operations represented by the new virtual instrument. Referring to FIG. 3A, a "generator list" 70 is suitably initially displayed as a window on the screen of terminal 26 when the system is loaded on the host computer 22. The generator list 70 lists the names of all existing virtual instrument classes. In this example, five virtual instrument classes are pre-existing: "Divider", "Logarithm", "Multiplier", "SignalGenerator", and "Voltmeter". At the same time, an instance or instrument list 72, shown in FIG. 3B, naming every instance of each class, is suitably displayed in a different window on the screen. In the particular example of FIG. 3B the instrument list 72 is empty, since no instance of any virtual instrument class has been created.

In order to synthesize the gainmeter virtual instrument, it is necessary to create new instances of the Divider, Logarithm, Multiplier, SignalGenerator and Voltmeter classes because the gainmeter virtual instrument will, utilize one instance from each of these classes in carrying out its function. To create such a new instance of a class, the operator selects the class by using the mouse connected to terminal 26 to move a cursor over the name of the class, such as "Divider" in the generator list 70, and presses and releases the red mouse button to select the "Divider" name. Then the yellow button is

depressed causing a first command menu 74, as shown in FIG. 3C, to appear as a further window on the terminal screen. This first command menu displays a set of five command names: "new instance", "synthesize", "add", "delete", and "inspect me". The operator then moves the cursor over the "new instance" command name and releases the yellow mouse button. Thereupon the first command menu window closes, and a new instance of the Divider class is created. The name of the new instance of the Divider class, "aDivider12", is added to the instrument list 72 as shown in FIG. 3D, and a virtual front panel for the instrument, similar to that shown in FIG. 2C, is displayed in another window on the screen of terminal 26. The name "aDivider12" is displayed at the top of the virtual instrument panel and indicates the instrument belongs to the Divider class. The number "12" at the end of the instance name is an arbitrary but unique number for each virtual instrument instance, used to distinguish this virtual instrument instance from any other virtual instrument instance.

In a similar manner, the operator uses the cursor and the first command menu 74 of FIG. 3C to create new instances of the Logarithm, Multiplier, SignalGenerator, and Voltmeter classes. Thereafter the instance or instrument list would appear as illustrated in FIG. 3E, listing the names of the new virtual instrument instances, "aDivider12", "aLogarithm13", "aMultiplier14", "aSignalGenerator15", and "aVoltmeter16". The virtual front panels associated with each new virtual instrument instance, similar to those depicted in FIGS. 2A-2D, are also displayed as separate windows on the screen of terminal 26.

Next, in order to create a new virtual instrument such as a gainmeter, the operator must create a new class, the class being assigned a suitable name such as "Gainmeter". To create the new class the operator presses the yellow mouse button to cause the first command menu 74 of FIG. 3C to be displayed, moves the cursor over the "add" command, and then releases the yellow mouse button. The system then closes the first command menu window and opens a dialog window 78, as illustrated in FIG. 3F, containing an upper portion 76 displaying a character string "add generator named:", and a lower portion 80 for displaying a character string naming the new class, when provided by the operator. The operator types in the class name, such as "Gainmeter", using the keyboard of terminal 26 and actuates a return button on the keyboard. The dialog window is then closed and the name "Gainmeter" is added to the generator list 70 as illustrated in FIG. 3G. At this time the system automatically produces software necessary to establish the new class according to a standard predefined template.

Once the Gainmeter class is created, the operator can "synthesize" the gainmeter, i.e., define the function an instance of the gainmeter class is to perform in terms of the functions which the existing virtual machines or instruments perform. To synthesize the gainmeter, the operator uses the cursor to select the Gainmeter item on the generator list 70 of FIG. 3G and operates a mouse button to open the first command menu 74 of FIG. 3C. The operator then employs the cursor and a yellow mouse button to select the "synthesize" command from the first command menu thereby causing the system to close the first command menu window and to display a new "synthesizing" window 82 as illustrated in FIG. 4. The synthesizing window includes three regions, a top region 84 for defining the virtual front panel associated with the virtual instrument being synthesized, a middle region 86 for displaying a Smalltalk listing of a procedure to be performed by the virtual instrument as it is generated, and a bottom region 88 containing a list of the input and output parameters associated

with the procedure as well as output parameters for lower level virtual instruments and temporary variables. The parameters don't appear until the operator defines them.

An end product of the synthesizing process is a Smalltalk listing, displayed within region **86**, of a method named "runMe" which performs the gainmeter function, i.e., which accepts input data indicating the voltage and frequency of a signal to be applied to an input of a device under test, adjusts the signal generator of FIG. **1** to produce such a signal, obtains the output voltage of the device measured by the voltmeter of FIG. **1**, and computes the gain from the signal generator output voltage and the voltmeter reading. It is convenient to first discuss the completed listing for the runMe method of the gainmeter and then describe how the present invention assembles it. The Smalltalk code for the runMe method is as follows:

```
runMe
|q5 q4 q3 q2 q1 t|
"Gainmeter"
"1 October 1985"
t ←(Generator InstrumentList) at:
    'aSignalGenerator15'.
t frequency: (self atFreq).
t amplitude: (self inLevel).
q1 ←t runMe.
t ←(Generator InstrumentList) at: 'aVoltmeter16'.
q2 ←t runMe.
t ←(Generator InstrumentList) at: 'aDivider12'. [11]
t denominator: (self inLevel).
t numerator: (q2).
q3 ←t runMe.
t ←(Generator InstrumentList) at: 'aLogarithm13'.
t number: (q3).
t base: 10.
q4 ←t runMe.
t ←(Generator InstrumentList) at: 'aMultiplier14'.
t left: 20.
t right: (q4).
q5 ←t runMe.
^ self measuredGain: q5 "Replace Me"
```

Line [1] is the title of the method, runMe. Line [2] declares q5, q4, q3, q2, q1 and t as temporary variables. Line [3] is a comment identifying the runMe method as being associated with the Gainmeter and line [4] is a comment indicating the date when the runMe method was created. In line [5] the variable t is made to reference the aSignalGenerator15 object on the Generator InstrumentList. In other words, when the variable t is then used to designate an object, the designated

object is the aSignalGenerator15 virtual instrument. In line [6] a message is sent to the aSignalGenerator15 virtual instrument which assigns the value of the Gainmeter (referenced by the word "self") input parameter atFreq to the frequency input parameter of aSignalGenerator15. In line [7] a message is sent to the aSignalGenerator15 object which assigns the value of the gainmeter input parameter inLevel to the amplitude input parameter of aSignalGenerator15. In line [8] a "runMe" message is sent to the aSignalGenerator15 virtual instrument which causes it to set the frequency and amplitude controls of the signal generator **14** of FIG. **1** consistent with the atFreq and inLevel input values provided in lines [6] and [7]. Also in line [8] an output of the aSignalGenerator15 runMe method, an indication of method completion, is assigned to a variable q1.

In line [9] the t variable is reassigned to reference the aVoltmeter16 virtual instrument on the generator instrument list and in line [10] a runMe message is sent to the aVoltmeter16 virtual instrument causing it to acquire the output voltage measured by the voltmeter **16** of FIG. **1** and to assign the value of the measured voltage (V2 in equation [A] hereinabove) to another variable q2.

In line [11] the variable t is reassigned to reference the aDivider12 virtual instrument and in lines [12] and [13] messages are sent to aDivider12 causing it to assign the value of the inLevel gainmeter input parameter (V1 in equation [A] hereinabove) to the denominator parameter of aDivider12 and to assign the q2 variable (i.e., V2) of line [10] to the numerator parameter of aDivider12. In line [14] a runMe message is sent to aDivider12 causing it to divide the numerator parameter by the denominator parameter thereby producing an output quantity equal to V2/V1. Also in line [14] the aDivider12 output is assigned to another variable q3.

In line [15] the variable t is reassigned to reference the aLogarithm13 virtual instrument and in lines [16] and [17] messages are sent to aLogarithm13 causing it to assign the value of the q3 variable (V2/V1) to the number parameter of aLogarithm13 and to assign the constant **10** to the base parameter of aLogarithm13. In line [18] a runMe message is sent to aLogarithm13 causing it to produce an output quantity equal to the log to the base **10** of number (i.e.,  $\text{Log}_{10}(V2/V1)$ ). This quantity is assigned to the variable q4.

In line [19] the variable t is reassigned to reference the aMultiplier14 virtual instrument and in lines [20] and [21] messages are sent to aMultiplier14 requesting it to assign the constant **20** to its left parameter and to assign the variable q4 produced in line **18** as its right parameter. In line [22] a runMe message is sent to aMultiplier14 causing it to produce an output quantity equal to the 20 times q4, i.e.,  $20\text{Log}_{10}(V2/V1)$ . This output quantity is assigned to the variable q5. Finally, in line [23], the measured gain of the device under test q5 is assigned as the Gainmeter output parameter, measuredGain, and this value is returned.

The above runMe method listing for the gainmeter virtual instrument is produced during the synthesis process and displayed in region **86** of the synthesizing window **82** of FIG. **4**. Initially, when the window is opened, lines [1]-[4] are automatically displayed in region **86**, followed by a fifth line:

```
^ self myValue: self myValue "replace me" [23a]
```

This last line is a precursor to line [23] of the runMe listing wherein the instance of "myValue:" is a dummy variable subsequently to be replaced during the synthesizing process by "measuredGain:" and wherein the following "self myValue" dummy expression is subsequently to be replaced

by the "q5" variable as described hereinbelow. The remaining lines [5]-[22] are also inserted into the listing during the synthesizing process.

Referring again to the synthesizing window 82 of FIG. 4, the top region 84 of window 82 is divided into three subregions. The first subregion 90 of top region 84 contains a list of the names of the input and output parameters of the synthesized virtual instrument. Initially subregion 90 is empty because the input and output parameters of the instrument have not been defined. A second subregion 92 of window region 84 contains a list of parameter types and a pair of selection boxes 94 and 96 for indicating whether a parameter is an input or an output of the synthesized virtual instrument. In this example, the possible parameter types include "function" (e.g., selection from a list such as square, sine, triangle), and "number" (a floating point decimal number). However, in other applications, other types of parameters may be included in the parameter type list including integers, character strings, binary numbers, etc. A third subregion 98 of window region 84 includes a list of the possible types of virtual front panel displays available for each parameter including in the present example, "linearGraph", "linearMeter", "logGraph", and "logMeter" which are adapted to display the value of a number. The "volts" display 36 of the voltmeter virtual front panel of FIG. 2B is an example of a linearGraph display wherein the value of a parameter is displayed as a bar of proportional length. The "left" meter 56 of the multiplier virtual front panel of FIG. 2E is an example of a linearMeter display wherein the value of a parameter is proportional to the position of a pointer on a dial. The "inLevel" display 64 and the "atFreq" 66 displays of the gainmeter of FIG. 2F are examples of the logGraph and logMeter displays wherein, respectively, the value of parameter is logarithmically proportional to the length of a bar or the position of a pointer on a dial. In other applications of the present invention, the list of possible displays in subregion 98 may be expanded to provide for displays of other types of parameters including, for example, an alphanumeric readout for displaying character strings, simulated lamps for displaying binary parameter states, selectors from lists, etc.

The operator may define an input or output parameter for the synthesized instrument by adding it to the parameter list in subregion 90. First the cursor is moved over the subregion and a yellow mouse button is pressed to open a second command menu window 100 as illustrated in FIG. 3H superimposed over region 90. This window includes four commands, "add", "delete", "new instance" and "inspect parameter". The operator then moves the cursor over the "add" command and releases the mouse button. The system then closes the second command window and opens a dialog window similar to that shown in FIG. 3F, except requesting "add parameter named". At this point the operator types the name of a parameter such as "atFreq" and then presses a carriage return button on the terminal keyboard. The system displays the name "atFreq" in subregion 90 with the name highlighted and also highlights the "input" selection box in subregion 92 as well as the "linearGraph" display type in subregion 98, to indicate that the highlighted parameter atFreq is, by default, a floating point number input to the gainmeter to be displayed as a linear graph on the virtual front panel for the gainmeter. The operator may change the nature of the front panel display for a parameter in highlighted subregion 90 by placing the cursor over the desired display type in subregion 98 and depressing the red mouse button. Similarly the operator may change the parameter type and whether it is an input or an output by using the cursor and red button to select the appropriate defining words in subregion 92. Next, in the same manner in which the

operator used the cursor in the second command window to add and define the atFreq parameter, the operator also adds and defines the "inLevel" and "measuredGain" parameters. At this point all three parameters appear in the input/output parameter list of subregion 90 as seen in FIG. 4.

Each time the operator adds an input or an output parameter to the parameter list of subregion 90, a line is added to region 88 listing the parameter. As shown in FIG. 4, the first line in the "bind list" of region 88 reads "self atFreq" indicating a parameter atFreq has been defined according to the front panel specifications of the gainmeter ("self"), rather than according to the specifications of some other virtual instrument on the instrument list. Similarly, when the operator adds the inLevel and measuredGain parameters to the parameter list of subregion 90, the system displays second and third lines in region 88 reading "self inLevel" and "self measuredGain".

At this point the operator has defined the virtual front panel for the gainmeter, as illustrated in FIG. 2F wherein the gainmeter virtual front panel is analogous to a "real" front panel as would be required for a "real" gainmeter and which could be constructed from hardware components. A real front panel for a gainmeter would include a knob for controlling and indicating output signal frequency, a knob for controlling and indicating output signal voltage, and a meter for displaying gain. In order to construct a "real" gainmeter it would be necessary to interconnect the front panel with inputs and outputs of various hardware components capable of producing a test signal, to measure a voltage and to perform a gain calculation. Similarly, in order to cause the virtual front panel of a virtual gainmeter instrument to operate properly it is necessary to create the runMe code for the gainmeter virtual instrument for directing the flow of messages which "interconnect" the gainmeter virtual front panel with the aDivider12, aLogarithm13, aMultiplier14, aSignalGenerator15 and aVoltmeter16 virtual instruments, in a fashion analogous to the wired interconnection of corresponding hardware instruments.

First, the operator selects the first virtual instrument to be utilized by the gainmeter, aSignalGenerator15, by moving the cursor over the displayed virtual front panel for the aSignalGenerator15, illustrated in FIG. 2A, and clicking a button on the mouse. The "a SignalGenerator15" label on the front panel is then highlighted to indicate the selection. To test the operation of the virtual signal generator and the corresponding real signal generator, the operator may set test values for the frequency and amplitude input parameters of the virtual signal generator, operate the virtual signal generator and then measure the output of the corresponding real signal generator to see if it produces a signal with the desired voltage and frequency characteristics. To adjust an input parameter of a virtual instrument after selecting the instrument, the operator moves the cursor over the meter area of a panel meter or a bar graph meter, depresses a red selection button on the mouse, moves the cursor to move the pointer or the bar to the desired position on the meter, and releases the red button. This is analogous to moving a knob or a slide control on a real front panel. Alternatively, the operator may select a meter and then operate a yellow button on the mouse to open a third command menu window 102 as illustrated in FIG. 3I listing "generate", "run", "stop", "inspect me" and "set parameters" commands. When the operator selects the set parameters command with the cursor, third command menu window 102 is replaced with a dialog window 104 as illustrated in FIG. 3K. In the example of FIG. 3K the operator has selected the frequency meter of the signal generator virtual front panel 28 of FIG. 2A. The dialog window 104 requests the operator to

type in a new value for frequency. In this example, the operator has responded by typing in "1325". When the operator presses the carriage return, the dialog window **104** disappears and the frequency meter **30** of FIG. **2A** is set to the new value. Assuming that the operator has now set the frequency parameter to 1325 and the voltage parameter to 5.59, the operator may "run" the signal generator virtual instrument by opening the third command menu window **102** of FIG. **3I** and selecting the "run" command. This causes the signal generator virtual instrument to send the frequency and amplitude data to the real signal generator **14** of FIG. **1** along with a signal causing it to operate. The operator may then test the output of the real signal generator to see if it produces a signal of the desired voltage and frequency. After the output of the signal generator **14** is tested, the operator may stop the operation of the signal generator by selecting the virtual signal generator, opening the third command menu window of FIG. **3I**, and selecting the "stop" command, thereby causing the virtual signal generator to send a stop instruction to its real counterpart.

Once operation of the virtual signal generator is verified (if such is desired), the code for "connecting" the virtual signal generator to the aGainmeter1 front panel may be synthesized. First, the operator uses the cursor and a red mouse button to select the last line of the listing currently displayed in region **86** of the synthesizing window of FIG. **4**. The operator then selects the aSignalGenerator15 front panel, uses a mouse button to open the third command menu window **102** of FIG. **3I**, and selects the "generate" command. This causes the system to insert the following code lines immediately preceding the selected line, in this case the last line in region **86**:

```
t ←(Generator InstrumentList) at: 'a
SignalGenerator15'. [5]
t frequency:1325. [6a]
t amplitude:5.59. [7a]
q1 ←t runMe. [8]
```

These lines are similar to lines [5]-[8] of the completed runMe listing except that in lines [6a] and [7a] the frequency variable is assigned its current test setting of 1325 Hertz and the amplitude variable is assigned its current test setting of 5.59 volts rather than the values of atFreq and inLevel indicated in lines [6] and [7] of the completed listing. At the same time lines [5], [6a], [7a], and [8] are added to the listing in region **86**, the q1 variable produced in line [8] is added to the bind list in region **88**, as well as to the temporary variable declarations in line **2**.

The operator may now "connect" the inLevel and atFreq parameters of the Gainmeter so that the virtual signal generator inputs may be set from the inLevel and atFreq inputs of the Gainmeter. To connect the atFreq parameter to the frequency input of the aSignalGenerator virtual instrument, the operator uses the cursor and a red selection button on the mouse to select line [6a] of the listing in region **86** and the "self atFreq" line of the bind list in region **88** and then operates a yellow selection button on the mouse to open a fourth command menu window **106** as illustrated in FIG. **3J**. The fourth command menu window lists the commands "modify code", "delete", "clear", and "inspect". At this time, the operator selects the modify code command which causes the system to modify the code of line [6a] so that it reads as in line [6] of the completed, runMe listing hereinabove by replacing the number 1325 with "(self atFreq)". In a similar fashion, the operator modifies Line [7a] to read as in line [7] of the completed listing by selecting line [7a] in region **86**, selecting the "self

inLevel" line from the bind list in region **88** and then selecting the modify code command from the fourth command window **106** of FIG. **3J**.

Next the operator selects the aVoltmeter **16** front panel **34** of FIG. **2B** and may test its operation by applying a known reference voltage to voltmeter **16** of FIG. **1**, selecting the "run" command of the third command menu **102**, and checking meter **36** of the aVoltmeter16 front panel to see that it properly indicates the reference voltage. The operator then inserts lines [9] and [10] into the runMe listing in region **86** by selecting the last line of the listing, selecting the aVoltmeter16 front panel, and then selecting the "generate" command from the third command menu **102** of FIG. **3I**.

```
t ←(Generator InstrumentList) at: "aVoltmeter16". [9]
q2 ←t runMe. [10]
```

At the same time these lines are inserted into the listing in region **86**, the q2 variable is added to the bind list in region **88** and to the temporary variables in line **2** of region **86**.

In similar fashion the following lines are added to the listing in region **86** when the operator selects the aDivider12 instrument and the generate command of the command menu **102** of FIG. **3I**:

```
t ←(Generator InstrumentList) at: "aDivider12". [11]
t denominator: 1. [12a]
t numerator: 1. [13a]
q3 ←t runMe. [14]
```

The q3 variable is also added to the bind list in region **88** of the synthesizing window **82** of FIG. **4**, and to line **2** of region **86**. At this point the operator modifies line [12a] to replace the "1" constant with (self inLevel) by selecting line **12a** and the "self inLevel" parameter in region **88**, and then selecting the modify code command from the command menu **106** of FIG. **3J**. The operator also modifies line [13a] in similar manner except that the q2 variable in the bind list of region **88** is selected to replace the constant "1" in line [13a].

In a similar fashion, the operator may select and use the generate and modify code commands of the menu of FIG. **3J** to insert code lines [15]-[22] into the runMe listing for the aGainmeter1 virtual instrument displayed in region **86** of the synthesizing window. Finally, the operator must modify the last line [23a] of the code in region **86** to match line [23] of the completed runMe listing. To do so the operator selects line [23a] and uses a mouse button to open a command menu window **108** of FIG. **3L** which lists the commands "modify code", "edit code", "add code", "clear code", "reset code", "compile message", and "inspect code". The operator selects the "edit code" command in the menu and the menu is then replaced with dialog window **110** as illustrated in FIG. **3M** which contains selected code line [23a]. This dialog window permits the operator to use the cursor to indicate the dummy variables to be replaced and to type in the appropriate information (as hereinbefore mentioned) in their place.

With the runMe code for the gainmeter synthesized, the complete code for the gainmeter virtual instrument may now be compiled. To do so, the operator opens the command menu window **108** of FIG. **3L** and selects the "compile message" command. Once the code is compiled, the synthesis process for the Gainmeter class is complete and the operator may create an instance of the Gainmeter class by selecting the "Gainmeter" class from the Generator list window **70** of FIG. **3G**, opening the command menu window **74** of FIG. **3C** (or opening the command window **100** of FIG. **3H** in region **90**,

of the synthesizing window of FIG. 4), and selecting new instance. Thereafter the aGainmeter1 virtual front panel 62 of FIG. 2F is displayed.

This instance of the gainmeter virtual instrument may be operated in the same manner any other virtual instrument is operated. The inLevel and atFreq control inputs may be modified by using the cursor to set the appropriate meter settings (or by typing the desired values into a dialog window) and then selecting the run command from the command menu of FIG. 3I.

When the operator no longer wishes the front panel of a virtual instrument to be displayed, he may select such front panel and then open the blue button menu window 112 as illustrated in FIG. 3N, displaying "under", "move", "frame", "collapse", and "close" commands. The close command removes the selected panel from view, the under command causes a selected window to appear beneath any overlapping windows, and the move command permits the operator to relocate any selected window by using the cursor to move the window across the screen to a new position. The frame command permits the operator to use the cursor to resize a window by moving a corner of the window. The collapse command shrinks a selected window until only its title is shown on the screen. A collapsed window may be opened again by selecting the frame command from the blue button menu. It will be realized that all these functions are performed by commercially available graphics software, such as Smalltalk 80.

Referring to FIG. 3C, the command menu 74 includes a delete and an inspect me command in addition to the new instance, synthesize and add commands previously discussed. The operator may delete an instrument class by selecting the class on the generator list 70 of FIG. 3G, opening command menu 74 of FIG. 3C and selecting the delete command. The inspect me command invokes a standard Smalltalk feature which enables the operator to obtain information regarding a selected object, in this case a virtual instrument class. The add code command of the command menu of FIG. 3L permits an operator to type in a line of code in a selected location within the runMe listing region 86 and the clear code command permits the operator to clear the entire code. The delete command permits him to delete a selected line of code. The reset code command permits the operator to restore the code to the initial value as in FIG. 4.

The Smalltalk software for the preferred embodiment of the present invention is implemented using three system categories: "MyInstruments", "Synthesizer", and "InterfaceMeters". The MyInstruments system category includes virtual instrument classes. Appendix I also found in parent application Ser. No. 06/798,931, filed Nov. 18, 1985, now U.S. Pat. No. 4,849,880 includes listings for example virtual instrument classes for adding and multiplying.

The Adder virtual instrument class listing appears on the first page of Appendix I and will be discussed in detail by way of example. The other virtual instrument class listings are structured in a similar fashion as will be apparent to those skilled in the art.

Referring to the Adder virtual instrument class listing, line (1) identifies the virtual instrument subclass "Adder" and line (2) defines three instance variables: left, output and right. Lines (3) and (4) indicate the VirtualInstruments class has no class variables and no pool dictionaries. Line (5) identifies the class category, myInstruments.

Each instrument subclass has two groups of instance methods, "parameters" and "set values". The parameters methods include methods to set and read the values of selected instance variables and a runMe method to carry out the operation of the

virtual instrument. The setValues methods provide the prompt in dialog windows of the type shown in FIG. 3K when the operator uses the "set frequency" command of the command menu of FIG. 3I to specify a frequency value. When a different meter is selected, the word frequency in menu 102 is replaced by the name of the parameter displayed by the meter.

Line (6) introduces the parameter methods and line (7) defines a first parameter method corresponding to the selector "left" which returns the value of the left variable to any object sending a "left" message to the adder. If the value of the left variable has never been set, i.e., it is "Nil", the method sets the value of the left parameter to 1 and returns 1 as the parameter value. This line also includes comments indicating the date when the method was last modified, the variable type (number), the type of meter used to display the variable (linear-Graph), and whether the variable is an input or an output. Line (8) defines a second parameter method responding to the selector "left:". This method sets the value of the left variable to any value specified in a message of the form left:xx, where xx is the specified value. The method returns the set value of left to the message sender. Similarly, lines (9), (10), (11) and (12) define methods responding to the selectors "output", "output:", "right", and "right:" which permit the interrogation and setting of the output and right variables in the same manner that lines (7) and (8) permit interrogation and setting of the left variable.

Lines (13)-(18) define the parameter method executed in response to a runMe method. Line (13) recites the runMe selector and lines (14) and (15) are comments indicating the class (Adder) and the date of creation of the class. Line (16) defines a temporary variable, t. In line (17) the value of the left parameter and the value or the right parameter are obtained by using the left and right methods of lines (7) and (11). The two values are summed and the sum is assigned to a variable "my Value" which is returned to the object which sent the runMe message. Line 17 also invokes the "output:" method to set the output parameter on the virtual front panel of an adder.

Line (19) introduces the setValues methods, the first of which is defined in line (20) as responsive to a message containing a "setleft" selector. This line returns a character string "left value?" to be placed in a dialog window when the operator is to type in a new parameter value after having invoked the setleft command. The methods of lines (21) and (22) are similar to the method of line 20 except that line (21) relates to the setting of the output parameter and line (22) relates to the setting of the right parameter.

The above listing for the Adder subclass is structured in a fashion which is typical for all virtual instrument subclasses, each having a pair of parameter methods similar to "left" and "left:" of lines (7) and (8) and a setValues method similar to that of line (20) associated with each parameter. Also each has a runMe method similar to that given in the adder example and designed to implement the primary function of the virtual instrument. The code for the runMe method, associated a virtual instrument which sends data to and/or receives data from a real instrument such as a signal generator or a voltmeter, includes provisions for sending data out on the bus to the receiving instrument and/or acquiring data over the bus from the instrument in a well known manner.

Appendix II also found in U.S. Pat. No. 4,849,880 is a listing of a new Smalltalk system category "Synthesizer", according to the present invention, which includes three new Smalltalk classes: "Generator", "ParameterBlok", and "VirtualInstruments". Generator is a new subclass of the standard Smalltalk class "Object" while Parameterblok and VirtualInstruments are new subclasses of the standard Smalltalk class "Number". Each virtual instrument class is a subclass of

VirtualInstruments. The Generator class, also diagrammed in FIG. 6, includes instance methods 120 and class methods 122 invoked during the creation of new classes of virtual instruments and new virtual instrument instances, and invoked to control the operation of the virtual instruments instances. The ParameterBlok class, also diagrammed in FIG. 7, includes a class method 124 and an instance method 126 invoked to create and maintain records of the attributes (i.e. name, type, value, meter view, etc.) of the various input and output parameters associated with each virtual instrument. The VirtualInstruments class, also diagrammed in FIG. 8, includes class methods 128 and instance methods 130 also invoked during the creation of virtual instrument instances, providing common display messages for the virtual instrument classes.

The virtual instrument classes are used as "generators" to generate new virtual instrument instances, and these classes are included in a data structure called "GeneratorList". The names of these generator classes are displayed on a generator list 70 illustrated in FIG. 3D. The names of the virtual instrument instances available for a project are displayed on an instrument list 72 as illustrated in FIG. 3E.

Referring to FIG. 6, the generator class is initialized by an "initialize" method which calls an "addGeneratorSpec:parameters:" method to add the available virtual instruments to the generator list and to invoke a "compileGenerator:" method which compiles the generator classes. Initially when an operator opens a project, the operator types and executes the line, "Generator example". This calls the generator class method "example" which in turn calls the methods "displayGenerators" and "displayInstruments" to initiate the display of the generator list 70 of FIG. 3C and the instrument list 72 of FIG. 3B. Once the generator list is displayed, the operator may select a generator using the cursor and the red mouse button, thereby invoking a "wakeGenerators" method which sets a variable indicating the selected generator. The operator may open the generator command menu 74 of FIG. 3C by operation of the yellow mouse button which invokes a "generatorMenu" method for displaying the menu. The operator may delete the selected generator from the generator list by selecting the delete command from the menu, calling a "deleteGenerator" method. The operator may inspect a selected generator by selecting the inspect me command from the menu whereupon an "inspectSelectedGenerator" method is called which invokes a standard Smalltalk inspect method.

The operator may add an instance of a virtual instrument to the instrument list by selecting the appropriate generator on the generator list and then selecting the new instances command on the generator menu 74 of FIG. 3C. An "addInstrument" method is called which obtains the name of the selected generator and passes it to an "addInstrument:" method. The "addInstrument:" method adds the name of the virtual instrument instance to the instrument list and invokes a "newInstance" method which initiates display of the virtual front panel for the new virtual instrument. The "addInstrument:" method also invokes a VirtualInstruments class method "new:" (listed in FIG. 8) which creates the new instance of the instrument and initializes it with a name and a parameter block. The "new:parameters:" method calls a VirtualInstruments instance method "initialize:", setting the values of the parameters in the parameter block associated with the new virtual instrument instance.

The operator may select a virtual instrument instance on the instrument list using the cursor and the red mouse button and may open an instrument command menu 73 as illustrated in FIG. 3P by depressing the yellow mouse button when the cursor is within the instrument list. The front panel of a selected virtual instrument is displayed if the operator selects

a "show me" command from the instrument command window, invoking a "showSelectedInstrument" method to initiate the display. The operator may "run" a selected virtual instrument by selecting the run command which calls a "runSelectedInstrument" method for sending a "runMe" message to the selected virtual instrument. The operator may add a new instance of a selected virtual instrument by selecting the add command to invoke the "addInstrument" method discussed hereinabove. The operator may inspect a selected virtual instrument by choosing the inspect command which calls an "inspectInstrument" method invoking the Smalltalk inspect method, and can delete a selected virtual instrument instance by selecting the delete command from the instrument list menu to call for a "deleteInstrument" method for removing the selected instrument from the instrument list. The generate command on the instrument menu is discussed hereinbelow in conjunction with the synthesis process methods.

When a virtual front panel is displayed, the operator may open the meter menu 102 of FIG. 3I by placing the cursor over a meter and operating the yellow button to call for a "makeYBM:" instance method of the virtualInstruments class (FIG. 6). Referring to FIG. 6, the run, stop and inspect me commands invoke, respectively, a "run" method for sending a runMe message to the virtual instrument, a "stopMe" method for sending a stopMe message halting instrument operation, and an "InspectMe" method invoking the Smalltalk "inspect" method. The set parameter command on the meter menu invokes a "setValue" method for opening a dialog window permitting the operator to type in a new value for the parameter displayed by a selected meter and sets the parameter to the new value. The generate command on the meter menu will also be discussed hereinbelow in conjunction with the synthesis process.

In order to synthesize a new generator, the operator first adds the generator to the generator list. To do so the operator uses the add command on the generator command menu 74 of FIG. 3C. Referring to FIG. 6, this command calls an "addGenerator" method for opening a dialog window permitting the operator to type in the name of the new generator and then calls an "addGenerator:" method which adds the generator name to the generator list and invokes a generator "new:" method. The "new" method creates a new generator instance and provides an instance method "initialize:" which creates the initial Smalltalk code listing for the runMe method for the new generator class. This initial listing includes the runMe code lines [1]-[4] and [22a] described hereinabove. These lines are obtained by a call to an "initialCodeList:" Generator class method which returns the code lines. The "initialize" method also initializes parameter and bind lists for the generator. After the "addGenerator:" method is completed, the "addGenerator" method invokes a "compileGenerator:" method which creates the new class by calling a standard Smalltalk method subclass:instanceVariableNames:classVariableNames:poolDictionaries:category:. The method "compileGenerator:" invokes the "makeParameterMessage:in:" Generator instance method which creates the parameter methods for the generator.

Once a generator appears on the generator list, the operator may "synthesize" the generator (i.e., alter its function) by opening the synthesis window. When the operator selects a generator to be synthesized from the generator list and utilizes the synthesize command on the generator menu, a "synthesize" Generator class method is called. This method then invokes the "displaySynthesis" instance method for the selected generator which opens the synthesis window 82 of FIG. 4. The window displays any existing input or output parameters on the parameter list in region 90 of the window

and on the bind list in region **88**, and displays the runMe code for the generator in region **86**. When the operator opens the parameter menu **100** of FIG. **3H**, a "parameterMenu" instance method is called to display the menu. The operator may add a parameter to the list by selecting the add command which calls an "addParameter" method for displaying a dialog window enabling the operator to type in a new input/output parameter name. After the name is typed in, "addParameter" passes the name to an "addParameter:" method which forwards the parameter name to an "addParameterToLis:" method for adding the parameter to the parameter list. Before adding the parameter to the parameter list the "addParameterToLis:" method initializes the parameter attributes (i.e. view, type, input/output) to default values by invoking a "setParameter:blok:" instance method. The "setParameter:blok:" method calls a set of ParameterBlok class instance methods (listed in FIG. **6**) "in:", "out:", "name:", "type:", "value:" and "view:". These methods specify the attributes of the parameter. The "addParameter" method also passes the parameter name to a "makeParameterMessage:in:" method which adds the parameter to the list of instance variables for the generator class, adds the variable to the bind list, and creates the instance methods for the class being synthesized for setting and returning the value of the new parameter.

A new parameter is initialized as an input of the "number" parameter type to be displayed on a linear graph. The operator may change these parameter attributes by using the cursor and the red mouse button to select the parameter and then the appropriate parameter attributes in region **84** of the synthesizing window. When either the Input or the Output parameter attribute is selected, or deselected, the "in:" or the "out:" parameter block instance method is invoked to set the input/output attribute for the parameter. When a parameter type (i.e., number or function) or parameter view (i.e., linearGraph, linearMeter, etc.) is selected, a "type:" method or "view:" method is used to set the selected parameter type or view. Whenever the operator selects a parameter on the parameter list, a "wakeParameter:" Generator instance method is called which highlights the selected parameter and the appropriate attributes displayed in region **84** of the window. The "wakeParameter:" method determines the appropriate view, type and input/output parameter attributes by invoking the parameterBlok methods ("view", "type", "in", and "out") and passing the returned data to instance methods ("sView:", "sType:", "myIn:", and "myOut:") which control the highlighting of the attributes. The "wakeParameter:" method then modifies the display by calling a standard Smalltalk method "changed:".

The operator can delete a parameter from the parameter list by selecting the parameter to be deleted and then selecting the delete command from the parameter menu **100** of FIG. **3H**, thereby calling for a "deleteParameter" Generator instance method which removes the parameter from the parameter and bind lists and updates the display. The operator can also inspect the parameter by selecting the inspect command from the parameter command menu to call an "inspectParameter" method which in turn invokes the Smalltalk inspect method. The operator can also create a new instance of the selected generator virtual instrument by selecting the "new instance" on the parameter command window of FIG. **3**. This calls a "newInstance" Generator instance method which utilizes the generator class method "newInstance" discussed hereinabove.

As part of the synthesizing process, the operator may insert new lines into the runMe listing in region **86** of the synthesizing window **82** of FIG. **4** which cause a synthesized virtual instrument to utilize another virtual instrument to perform a selected operation. First the instance of the selected virtual instrument is selected and then the generate command within

menu **73** of FIG. **3P** is selected. The generate command of the instance command menu invokes a "generateSelectedInstrument" Generator class method which in turn calls a VirtualInstruments instance method "generate". Selection of the generate command from menu **102** of FIG. **3I** calls the "generate" method directly. The "generate" method produces the runMe code lines. These lines are then inserted into the runMe code listing for the generator being synthesized just above a selected existing code line. The "generate" method calls a "nextQuad" Virtual instruments class method which returns the number to be appended to the "q" output variable for the code. "Generate" also adds the new "q" variable to the bind list.

The command menu **106** of FIG. **3J** is opened by invoking a "bindMenu" Generator instance method and the code command menu **73** of FIG. **3P** is opened by calling a "codeMenu" Generator instance method. When the operator selects a line of runMe code in region **86** of the synthesizing window, and a parameter on the bind list in region **88**, and then selects the modify command on the bind command menu, or the modify code command on the code menu, a "modifyCode" method is called. The "modifyCode" method changes the quantity to right of the colon on the selected code line to reference the selected bind list variable. The delete command on the bind menu **106** of FIG. **3J** initiates a "deleteBind" method which removes a selected parameter from the bind list while a clear command on the bind menu calls a "clearBindList" method to remove all parameters from the bind list. An inspect command on the bind menu invokes an "inspectBindList" menu which in turn calls the system inspect methods to permit the operator to inspect the bind list.

The operator can more directly edit the runMe code lines in synthesizing window region **86** by using other code menu commands. These additional code commands and methods permit an operator skilled in programming to develop virtual instrument primitives for carrying out functions not implemented by existing virtual instruments. A delete command invokes a "deleteCode" method which removes a selected line from the code list. An edit command calls an "editCode" method which opens a dialog window similar to window **110** of FIG. **3M** containing a selected line of code. An inspect code command invokes the system inspect method through an "inspectCode" method, thereby permitting the operator to inspect the code list. An add code command uses an "addCode" method which opens a dialog window permitting the operator to type in a new code line. The "addCode" method in turn calls an "insertCode:" method which inserts the dialog window code line into the code list just above a selected line, or at the end if no line is selected. A reset code command calls a "resetCode" method which returns the runMe code to its initial state, thereby removing all but the first four and last runMe code lines. A clear command invokes a "clearCode" menu which deletes every line from the code list. The operator selects a compile message command when the code list is complete and this command calls a "compileMessage" method which concentrates the runMe code list to a character string and sends it to the system compiler.

The following ParameterBlok instance methods return the value of the parameter attribute indicated by the method name: "in", "name", "out", "type", "value", and "view". The following ParameterBlok methods are invoked to set the value of the parameter attribute indicated by the method name: "in:", "name:", "out:", "type:", "value:", and "view:". A ParameterBlok class method "new" is used to create a new parameter block.

In addition to Generator methods discussed above, the Generator class instance methods include additional instance methods employed by the methods described above. The methods "sB", "sC" and "sP" return the currently selected binding parameter on the bind list, the currently selected line

of code from the runMe list and the currently selected parameter on the parameter list, respectively. The "sType" and "sView" methods return the currently selected parameter and meter types highlighted in the synthesizer window. A "getBindList" instance method returns the current bind list and an "InstrumentList" class method returns the current instrument list. The class and instance methods "typeList", "viewList", "bindList", "listInstruments" and "parameterList" sort and return the lists suggested by their names. The Generator instance method "codeList" and class method "codeList" both return the runMe code for a selected generator. A "selectedInstrument" method returns the name of an instrument currently selected on the instrument list, while a "selectedSynthesizer" method returns the name of the generator being synthesized. A "setName" method is employed to set an instance variable "instrumentName" to the name of the currently selected instrument while an "instrumentName" method returns the value of the variable. A "selectedBinding" method returns a currently selected line on the bind list. The following methods are utilized when selecting an item from a list: "wakeInstruments:" (when selecting an instrument from the instrument list), "wakeType:" (when selecting a parameter type from the parameter type list of the synthesizing window), "wakeBind": (when selecting a line on the bind list), and "wakeView:" (when selecting a meter from the meter list of the synthesizing window). The class methods "initCode", "initType", and "initView" return the runMe code line, parameter type and meter type currently highlighted in the synthesizing window.

The VirtualInstruments class includes instance methods for providing common display messages for the virtual instrument classes created by the generators. In the preferred embodiment of the present invention three types of displays are possible: bargraph, panel meter, and a "list meter". A list meter displays a list of operating mode options for the virtual instrument having more than one operating mode and the operator may select an operating mode from such a list. For instance, a signal generator virtual instrument may include a list meter allowing the operator to select between square-wave, sinewave, or trianglewave signal generator outputs. A list meter is thus a form of menu and is created by invoking a "listMeter:" method. When the operator accesses the list meter menu a "listMeterMenu:" method is involved which responds to the operators selections. A "parameterMeter" method is invoked to display a bargraph or panel meter and a "display" method is used to update the display of a meter when a virtual instrument parameter value is changed. The method "myParameters:" assigns a current parameter block to an instance variable, wherein "myParameters" indicates the current input parameter values for the instrument. A "myValue:" method sets the value of a "myValue" instance variable, indicating the value of the virtual instrument output variable while a "myValue" method returns the value of the variable. In addition to the "new" method, the VirtualInstruments class methods include "classKounterIncrement" which returns the value of the number to be appended to the generator name when creating the name for a new virtual instrument instance, "nextQuad" (discussed hereinabove) which returns the number to be appended to the next "q" output variable of a line of synthesized runMe code, "resetQuad" which initializes a counter used by the "nextQuad" method, and "zeroKounter" which initializes a counter used by the "classKounterIncrement" method.

Appendix III also found in U.S. Pat. No. 4,849,880 contains a listing of a new Smalltalk system category "InterfaceMeters", according to the present invention. The InterfaceMeters category includes a new "MeterView" subclass of the existing Smalltalk "View" class for controlling the display of the meters on the virtual frontpanels associated with each virtual instrument, a new "MeterController" subclass of the

existing Smalltalk "MouseMenuController" class for monitoring the cursor position and mouse button operation, and a new "MeterScale" subclass of the existing Smalltalk "Object" class for performing various calculations required by the MeterView when adjusting the display of a meter.

FIG. 5A lists the instance method names for the meter controller class. When the operator moves the cursor over a virtual instrument front panel meter displayed on the screen he may invoke a meter command menu such as 102 of FIG. 3I by operating the yellow mouse button. The operator may also invoke the window view command menu 112 of FIG. 3N by operating the blue mouse button and may change the value of the parameter displayed by using the red mouse button. The MeterController subclass methods monitor mouse button operation and cursor movement when the cursor is within the boundaries of a meter portion of a virtual front panel displayed on the screen. These methods send messages to the MeterView subclass indicating the position of the cursor and mouse button operations. The MeterView subclass uses information contained in these messages to adjust meter parameter values. When the cursor is in a meter window, the operator may adjust the meter reading by positioning the cursor over the meter pointer area (on a panel meter) or over the meter bar area (on a bargraph meter), depressing the red button on the mouse and then "dragging" the pointer or the bar to the desired position on the meter.

The MeterController subclass methods send messages to the MeterView subclass indicating the cursor position and mouse button operations. The MeterView subclass uses information contained in these messages to control the meter display. In the MeterController subclass, the "controlActivity" method determines when the operator has pressed the red mouse button, determines the position of the cursor, and then sends cursor position information to an instance of the MeterView subclass. An "isControlActive" method determines if the meter controller has control and gives precedence to the blue mouse button which opens the view command menu 112 window of FIG. 3N. A "newValueSymbol:" method sets an instance variable (newValueSymbol) to indicate the name of the method of the view to be invoked to send the view the mouse cursor position, while a "newValueSymbol" method returns the value of this variable. A "menuMessageReceiver" method returns the virtual instrument to which this virtual front panel corresponds. A "redButtonMenu:redButtonMessages:" method returns an error message if an attempt is made to set up a menu for the red button, since that button is used to set a graph or a meter.

The method structure of the object subclass MeterScale is depicted in FIG. 5B. Meterscale instance methods calculate the position of a panel meter pointer or the bar on a bargraph meter. A meterScale subclass "LinScale" includes methods for calculating a pointer or bar position on a linear scale while another meterScale subclass "LogScale" includes methods for calculating a pointer or bar position on logarithmic scale. The displacement of an indicating pointer or bar along a meter scale is referenced as a "Scale" number while the magnitude of the parameter is referenced as a "Value" number. The MeterScale subclass includes a "scaleToValue:" method, a "valueToScale:" method, and a "resetConstant" method which all return a message indicating that these methods are a subclass responsibility. A "maxScale" method returns the value of the upper limit of a meter scale displacement while a "maxScale:" method sets the upper limit of the Scale number. Similarly, a "maxValue" and a "MaxValue:" method return and set the value of the corresponding upper Value number limit. The "minScale", "minScale:", "minValue", and "minValue:" methods are provided to return and set the lower limits for the Value and Scale numbers.

The LinScale subclass of MeterScale instance methods includes a "scaleToValue:" method for returning the magni-

tude of a Value number corresponding a selected Scale number and a "valueToScale:" method for returning the magnitude of a Scale number corresponding to a selected Value number. A "conversionConstant" method returns a value of a conversion constant used by the "scaleToValue:" method and "valueToScale:" method. A "resetConstant" method is called to initially set the conversion constant to nil and the conversion constant is recalculated whenever the maximum or minimum value changes (e.g., when a value exceeds the maximum). The LogScale subclass of MeterScale has "conversionConstant", "resetConstant", "scaleToValue:" and "valueToScale:" instance methods which carry out functions similar to those of similarly named LinScale subclass methods but which are adapted to provide the proper conversions for logarithmic scales. The LogScale subclass also includes "maxValue:" and "minValue:" instance methods for setting the maximum and minimum parameter values. The methods override the similarly named methods in the MeterScale subclass.

The method structure of the MeterView class is depicted in FIG. 5C. Each instance of a MeterView subclass controls the display of a virtual instrument front panel meter. An "initialize" method, called when a meter is initially created, associates the meter with the current Smalltalk project, selects a pen to be used for drawing the meter, and then calls a "forceFullDisplayNextTime" method which wipes out any data in an image cache. Thus, when the meter is subsequently drawn onto the screen the meter display must be reconstructed from the meter model and not from the cache. (A saved image of the meter face is used in preference to drawing the meter afresh whenever possible, for reasons of efficiency.) An "itemName:" method sets parameters for display of the meter name. A "maxValue" method and a "maxValue:" method return and set the maximum value of the parameter to be displayed on a meter while a "minValue" method and a "minValue:" method return and set the minimum value of a number to be displayed. A "scale" method and a "scale:" method return and set the scale of the meter.

A "display" method of the MeterView subclass is called to initiate the display of a meter. As discussed hereinabove, each parameter of each virtual instrument is associated with two parameter methods, one for returning the value of the parameter and one for setting the value of the parameter. A "valueAccessSymbol:" method sets a variable "valueAccess" to the name of a virtual instrument parameter method to return the value of the parameter. A "valueFromModel" method is called to invoke the parameter method of the virtual instrument to return the value of a parameter. The "valueFromModel" method tests for the need to extend, and extends if needed, the limits of the number which may be displayed by the meter when the value returned exceeds the current range of the meter. A "valueChangeSymbol:" method sets a "valueChange" variable to the name of the virtual instrument parameter method for setting the value of the parameter and a "valueChange" method sends a message to the virtual instrument invoking that parameter method thereby setting the parameter to a new value. When parameter values in a virtual instrument change, a single update message containing the "updateOn" variable as its argument may be sent to each MeterView instance controlling each meter associated with the instrument thereby updating each meter display. An "update:" method updates the meter display either based on the last known value of the parameter or by acquiring a new value from the virtual instrument depending on whether the "selfOrSymbol" argument references the meterview or is equal to an "updateOn" variable. An "updateSymbol:" procedure sets the "updateOn" variable.

A single MeterView class procedure, "withScale:", is called to create a new instance of a meter with a scale (either linear or logarithmic) specified by the argument. In order to

display the value of a parameter on a meter, it is necessary to convert that value to an equivalent position on the meter. In the case of a bargraph meter the equivalent position is found in terms of horizontal displacement between the maximum and minimum scale positions while in the case of a panel meter the equivalent position is found in terms of an angular displacement along the meter. In the "BarGraphView" subclass of MeterView a "displayView" instance procedure provides the detailed instructions for drawing a bar graph meter and makes use of the appropriate MeterScale procedures to convert parameter values into equivalent meter position. A "newValue:" method changes the parameter value displayed on a meter in response to a message from the meter controller indicating the location of the cursor on the meter when the operator is using the red mouse button to change the meter reading. An "initScale" method is provided to set the initial value of the scale minimum when the meter is initially created.

The PanelMeterView subclass of MeterView includes a "displayView" instance method including instructions for drawing a panel meter and an "initScale" instance method which initially sets the minimum and maximum scale positions to -90 degrees and +90 degrees, respectively, thereby specifying a 180 degree full range scale. A "newValue:" instance method sets the current value of a displayed parameter to the value indicated by the current cursor position on the meter when the operator is using the red button to set the parameter value.

Once a virtual instrument class is synthesized according to the method described hereinabove the operator may create instances of the class which may be independently run to instruct the computer to perform a selected sequence of operations. In addition to utilizing a virtual instrument instance as an independent means to control computer operation, the operator may also utilize an instance of a synthesized virtual instrument for synthesizing other virtual instruments. For example, several instances of the synthesized gainmeter described hereinabove may be incorporated into a synthesized "frequency-response" virtual instrument for measuring the frequency response of an amplifier wherein each instance of the gainmeter is utilized to measure amplifier gain at a different frequency. The measuredGain outputs of each gainmeter may then be displayed on a group of contiguous bargraph meters to form a frequency response curve.

Therefore, the present invention provides a means for an operator to program a computer in a structured fashion by synthesizing a hierarchy of virtual machines with each successive virtual machine incorporating the functions of previously synthesized machines. The invention thus permits an operator not skilled in computer programming to create a virtual machine for performing a complex set of operations by first synthesizing and testing a set of less complex virtual machines for carrying out portions of the complex set of operations and then synthesizing the complex virtual machine based on the less complex machines.

While the preferred embodiment of the present invention described hereinabove is adapted to produce software for use in conjunction with a computer-based instrument system, the present invention may be adapted to produce software for other applications including, but not limited to, instrumentation control and data processing applications. Therefore, while a preferred embodiment of the present invention has been shown and described, it will be apparent to those skilled in the art that many changes and modifications may be made without departing from the invention in its broader aspects. The appended claims are consequently intended to cover all such changes and modifications as fall within the true spirit and scope of the invention.

## APPENDIX I

/usr0/bhuskar/myinstruments.st last modified Sep 12 10:20 1985 Page 1

```

(1) virtualinstruments variableSubclass: #Adder
(2) instanceVariableNames: 'left output right'
(3) classVariableNames: ''
(4) poolDictionaries: ''
(5) category: 'myinstruments';

(6) :adder methodsFor: 'parameters'!
(7) left " 28 August 1985 " " type:number view:linearGraph in:true out:false " ( left isNil ) ifTrue: [ ^ left _ 1 ]. ^ left;
(8) left: t " 28 August 1985 " " type:number view:linearGraph in:true out:false " ^ left _ t;
(9) output " 28 August 1985 " " type:number view:linearGraph in:true out:false " ( output isNil ) ifTrue: [ ^ output _ 1 ]. ^ output;
(10) output: t " 28 August 1985 " " type:number view:linearGraph in:true out:false " ^ output _ t;
(11) right " 28 August 1985 " " type:number view:linearGraph in:true out:false " ( right isNil ) ifTrue: [ ^ right _ 1 ]. ^ right;
(12) right: t " 28 August 1985 " " type:number view:linearGraph in:true out:false " ^ right _ t;
(13) runMe
(14) " Adder"
(15) " 28 August 1985"
| t |
self output: (myValue _ self left + self right).
^myValue! ;

(16) :adder methodsFor: 'setValues'!
(17) setleft|v| v _ FillInTheBlank request: 'left value?' initialAnswer: #nil. self left: v asNumber: changed: #metreValue;
(18) setoutput|v| v _ FillInTheBlank request: 'output value?' initialAnswer: #nil. self output: v asNumber: changed: #metreValue;
(19) setright|v| v _ FillInTheBlank request: 'right value?' initialAnswer: #nil. self right: v asNumber: changed: #metreValue; ;

```

/usr0/hhaskur/myInstruments.st last modified Sep 12 10:20 1985 Page 2

```

VirtualInstruments variableSubclass: #Multiplier
instanceVariableNames: 'left output right'
classVariableNames: ''
poolDictionaries: ''
category: 'myInstruments';

!Multiplier methodsFor: 'parameters':
left " 28 August 1985 " " type:number view:linearGraph in:true out:false " ( left isNil ) iffTrue: [ ^ left _ 1 ]. ^ left!
left: t " 28 August 1985 " " type:number view:linearGraph in:true out:false " ^ left _ t!
output " 26 August 1985 " " type:number view:linearGraph in:true out:false " ( output isNil ) iffTrue: [ ^ output _ 1 ]. ^ output!
output: t " 28 August 1985 " " type:number view:linearGraph in:true out:false " ^ output _ t!
right " 28 August 1985 " " type:number view:linearGraph in:true out:false " ( right isNil ) iffTrue: [ ^ right _ 1 ]. ^ right!
right: t " 28 August 1985 " " type:number view:linearGraph in:true out:false " ^ right _ t!

runMe " Multiplier"
" 11 September 1985"
| t |
self output: (myValue self left * self right).
^self myValue: self myValue .replace me";

!Multiplier methodsFor: 'setValues':
setleft|v | v _ FillInTheBlank request: 'left value?' initialAnswer: #nil. self left: v asNumber; changed: #metreValue!
setoutput|v | v _ FillInTheBlank request: 'output value?' initialAnswer: #nil. self output: v asNumber; changed: #metreValue!
setright|v | v _ FillInTheBlank request: 'right value?' initialAnswer: #nil. self right: v asNumber; changed: #metreValue! ;

```

## APPENDIX II

/usr0/hhakar/Synthesizer.at last modified Sep 12 10:12 1995 Page 1

```

Object subclass: # (Synthesizer
  instanceVariableNames: 'InstrumentName parameterList p codelist sc bindList s0 s1type sView myIn myOut kountur
  classVariableNames: 'GeneratorList InstrumentList Kountur SelectedGenerator SelectedInstrument SelectedSynthesizer TypoList ViolList
  poolDictionaries: ''
  category: 'Synthesizer';
  Generator comment:
    'an instance of a Generator is used
    in synthesizing new classes of virtual instruments.
    The state of each generator is determined from the following:
    Generator instance variables
    InstrumentName - holds the class name
    parameterList - dictionary of parameter name - parameter block associations
    p - currently selected parameter in parameter list
    codelist - ordered list of strings for runMessage currently being synthesized
    sc - currently selected string in codelist
    bindList - dictionary containing entry for each parameter for use in synthesizing code
    s0
    s1
);

!Generator methodsFor: 'initialize'.
addParameter: aName
    - creates parameter block aName in my parameter list
    - creates methods for accessing/setting parameter
    - adds parameter name to class instance variable list
    - adds binding string
    "
    self addParameterToList: aName.
    self makeParameterMessage: aName in: SelectedSynthesizer;

addParameterToList: aName
    - creates a new parameterBlock and
    - adds it to the parameter list for this instrument
    "
    self changeRequest (ifFalse: [aSelf changed: #wakeParameter]).
    parameterList at: aName put: (self block: aName).
    self changed: #wakeParameter;

block: aName
    "
    creates and initializes new Parameter block --
    used to describe the attributes and value of
    a parameter for a generator or instrument.
    | newBlock |
    newBlock ParameterBlock new.
    self setParameter: aName block: newBlock.
    newBlock;

getSelectedParameter
    "
    returns the parameter block
    for the currently selected parameter
    in the currently selected synthesizer

```

/usr0/bhasker/Synthesizer.st last modified Sep 12 10:12 1985 Page 2

```

sp isNil ifTrue: [
    nil.
]self putParameters at: sp
ifAbsent: [self notify: 'selected parameter not found', sp.
nil]]

initialize: aName
    set instance variables for a new Generator

self setName: aName.
parameterList _ Dictionary new.
codeList _ Generator initialCodeList: aName.
sc _ codeList last.
bindList _ Dictionary new.
aView _ #linearGraph.
myIn _ true.
myOut _ false.

makeParameterMessage: aName in: aClass
    does all the work of
    generating stuff for new parameters

] pName codeString newClass lastCode index newlastCode comments pBlock {
pName _ aName asSymbol.
add my name to the
list of class instance variable names
(Smalltalk at: aClass
ifAbsent: [self notify: 'mp'.
nil])
addInstVarName: pName.

    set up binding for input variables only
(cBlock _ parameterList at: aName ifAbsent: {self notify: 'missing p'}) in
ifTrue: [(GeneratorList at: aClass
ifAbsent: [self notify: 'message'.
nil]) getBindList at: pName put: self , pName.
self changed: #wakeBind].

fileCodeList to set output variables
insertion is a little kludgy
pBlock out
ifTrue: [lastCode _ codeList last.
codeList removeLast.
codeList addLast: (newlastCode _ 'self , ' , pName , '.').
codeList addLast: lastCode.
sc _ newlastCode.
self changed: #wakeCode].

```

```

/usr0/ibmuser/Synthmaker.st last modified Sep 12 10:12 1985 Page 3

comments . . . . Date today printString . " type: pBlok type . 'view' . pBlok view . in: . pBlok in printString .
out: . pBlok out printString . in:
enterString . pName . comments . ( . . pName . . isNil ) ifTrue: [ A . . pName . . _ 1 | A . . pName .
(newClass _ Smalltalk at: aClass
    ifAbsent:
        [self notify: 'message'.
          nil]) compile: codeString classified: 'parameters'.
newClass compile: (codeString pName . . . . comments . A . . pName . . t') classified: 'parameters'.
codeString _ 'set' . pName . . Tv | v _ FillInTheBlank request: . . . pName . . value? . InitialAnswer: nil . self . . pName . . : v
asNumber: changed: #metreValue
newClass compile: codeString classified: 'setValues';
setName: aString
instrumentName _ aString;

setParameter: aName blok: aB . . .
used by blok and modifyParameter
to set parameter blok values
from globals

sView isNil ifTrue: [sView _ #linearGraph].
sType isNil ifTrue: [sType _ #number].
aB name: aName; type: sType; view: sView.
aB == 'output'
    ifTrue: [aB in: false; out: true; value: 1.1]
    ifFalse: [aB in: myIn; out: myOut; value: 1.2];

:Generator methodsFor: 'actions'!
inspectMe
    #self inspect: !

:Generator methodsFor: 'displayParameter'!
addParameter
    | name temp |
    name FillInTheBlank request: 'add Parameter named ' . InitialAnswer: 'dummyPara'.
    self addParameter: ( name asSymbol);

deleteParameter
    | pName |
    self changeRequest ifFalse: [ #self changed: #wakeParameter].
    pName _ sp.
    (self confirm: 'really delete ' . pName . '?' )
        ifFalse: [ #self ].
    parameterList removeKey: pName ifAbsent: [self notify: 'cant find ' . pName].
    self changed: #wakeParameter.
    (Smalltalk at: SelectedSynthesizer ifAbsent: [nil])
        removeInstVarName: pName printString.
    (GeneratorList at: SelectedSynthesizer ifAbsent: [nil]) getBindList removeKey: pName ifAbsent: [self notify: 'cant find parameter
    ' . pName ].
    self changed: #wakeBind;

```

/usr/O/Uniback/Synthesizer.st last modified Sep 12 10:12 1985 Page 4

```

getParameters
    ^parameterList!
inspectParameter
    Generator selectedSynthesizer getSelectedParameter inspect!
newInstance
    " parameter yellow button menu entry point.
    self class newInstance!
parameterList
    ^parameterList keys assortedCollection!
parameterMenu
    "
    "
    ^actionMenu
    labels: 'add\delete\new instance\inspect Parameter' withCRs
    lines: #(3)
    selectors: #(addParameter deleteParameter newInstance inspectParameter)
wakeParameter: aSelection
    "
    "
    invoked by synthesis parameter selection in list view
    when parameter selection is changed.
    updates all fields to reflect currently selected parameter
    "
    | pBlock |
    sp_aSelection.
    sp isNil.
    ifFalse:
        |pBlock parameterList at: sp ifAbsent: [self notify: 'bad parameter' , sp printString].
        self sView: pBlock view.
        self sType: pBlock type.

```

/usr0/bhaakar/Synthesizer.et last modified Sep 12 10:12 1985 Page 5

```

self myIn: pBlock in.
self myOut: pBlock out.

self changed: #wakeType.
self changed: #wakeView; !

;Generator methodsFor: #displayCode;
addCode
"
this should allow the addition of arbitrary strings of code
from a text view.
| text |
text fillInTheBlank request: (' add befor ', sC) initialAnswer: #nil.
self insertCode: text.

```

```

clearCode
"
used by code subview of synthesis
to clear the code list
self changeRequest ifFalse: (^self changed: #wakeCode).
(self confirm: 'really clear all?')
ifFalse: [^self].
codeList _ OrderedCollection new.
sC nil _ OrderedCollection new.
self changed: #wakeCode

codeList
"
gets code list for synthesis display
^codeList

codeMenu
"

```

```

/usr0/bhaskar/Synthesizer.st last modified Sep 12 10:12 1985 Page 6
sublocators: #(modifyCinto editCode clearCode resetCode statusCode compileMessage inspectCode ):
compileMessage
map: codeList from orderedCollection to string
and hands off to format/compile

{ target tp cl codeString targetClass trailer tn aCompiler newText |
targetGenerator SelectedSynthesizer.
targetClass _ Smalltalk at: instrumentName
ifAbsent:
[ self notify: 'cant find ', instrumentName, ' to compile'.
nil ].
target isEmpty
ifTrue:
[ self notify: 'select a generator'.
self ].
codeString isEmpty ifTrue: [ nil ].
codeString String new: 0.
cl do: [ :c | codeString _ codeString , c , ' ].
this should really put up a controller
if a syntax error occurs.
aCompiler _ Compiler new.
newText _ aCompiler
format: codeString asText
in: targetClass
notifying: NoController new.
newText = nil ifFalse: [ codeString _ newText asString ].
targetClass compile: codeString classified: 'parameters'.
]

deleteCode
"
"
| index |
self changeRequest ifFalse: [ ^self changed; #wakeCode ].
index codeList indexOf: c.
[ self confirm: 'really delete selected code?' , (codeList at: index)
ifFalse: [ ^self ].
codeList remove: c ifAbsent: [ self notify: 'cant remove that ', c , ' , index printString ].
self changed; #wakeCode ].

editCode
"
this should allow the addition of arbitrary strings of code
from a text view.
"
| text |
self changeRequest ifFalse: [ ^self changed; #wakeCode ].
i _ codeList indexOf: c ifAbsent: [ ].
text _ FillInTheBlank request: 'edit code' InitialAnswer: (codeList at: i).
i = 0
ifTrue: [ self addLast: text ]
ifFalse: [ codeList
at: i

```

/usr0/bhaskar/Synthesizer.st last modified Sep 12 10:12 1985 Page 7

```

used by Generate
to insert code as aC in codeList
self changeRequest ifFalse: [aSelf changed: #wakeCode].
aC isNil
  ifTrue: [self addCode: aString]
  ifFalse:
    [codeList add: aString before: aC.
     self changed: #wakeCode].

```

```

inspectCode
  self codeList inspect!

modifyCode

```

```

used from yellow button menu to
replace operand source value
in selected codeList statement

```

```

[ s |
self changeRequest ifFalse: [aSelf changed: #wakeCode].
aC isNil
  ifTrue: [self notify: 'must select code to be modified!'.
           aNil].

```

```

s = aC copyUpTo: $.
s = s . i . $. ( ' . sb ' ) .
(sC indexOf: $.)
  > 0 ifTrue: [s = s . i . $.].
codeList indexOf: aC.
codeList at: 1 put: s.
self changed: #wakeCode!

```

```

resetCode

```

```

used by code subview of synthesis
to set code list to its initial value

```

```

self changeRequest ifFalse: [aSelf changed: #wakeCode].
(self confirm: 'really reset?')
  ifFalse: [aSelf].
codeList _ Generator InitialCodeList: self instrumentName.
VirtualInstruments resetQuad.
aC codeList last.
self changed: #wakeCode!

```

```

wakeCode: aSelection
aC _ aSelection! ;

```

```

iGenerator methodsFor: 'synthesis'!
displaySynthesis

```

```

| third half topview twoThirds sg |
sg = self.
third = 1 / 3.
twoThirds = 2 * third.

```

/usr0/haskar/Synthetizer.st last modified Sep 12 10:12 1985 Page 8

```

label: 'synthesis', instrumentName
minimumSize: 300 @ 400.

parameter listView
topView
  addSubview: (SelectionInListView
on: sg
  printItems: false
  oneItem: false
  aspect: #wakeParameter
  change: #wakeParameter
  list: #parameterList
  menu: #parameterMenu
  initialSelection: #sp)
  in: (0 @ 0 extent: third @ third)
  borderWidth: 1)
  addSubview: (BooleanView
on: sg
  aspect: #myIn
  label: 'input'
  change: #myIn
  value: true)
  in: (third @ (third * 0.8) extent: (third/2) @ (third * 0.2))
  borderWidth: 1)
  addSubview: (BooleanView
on: sg
  aspect: #myOut
  label: 'output'
  change: #myOut
  value: true)
  in: ((third/2 + third) @ (third * 0.8) extent: (third/2) @ (third * 0.2))
  borderWidth: 1)
  addSubview: (SelectionInListView
on: Generator
  printItems: false
  oneItem: false
  aspect: #wakeType
  change: #wakeType
  list: #typeList
  menu: #typeMenu
  initialSelection: #initType)
  in: (third @ 0 extent: third @ (third * 0.8))
  borderWidth: 1)
  addSubview: (SelectionInListView
on: Generator
  printItems: false
  oneItem: false
  aspect: #wakeView
  change: #wakeView
  list: #viewList
  menu: #typeMenu
  initialSelection: #initView)
  in: (2 * third @ 0 extent: third @ third)
  borderWidth: 1)
  addSubview: (SelectionInListView
on: sg
  printItems: true
  oneItem: false
  aspect: #wakeCode

```

/usr0/bhaskar/Synthesizer.s1 last modified Sep 12 10:12 1985 Page 9

```

menu: #codeMenu
initialSelection: #sc
borderWidth: 1
addSubview: (SelectionInListView
on: sp
printItems: false
onItem: false
aspect: #wakeBind
change: #wakeBind
list: #bindList
menu: #bindMenu
initialSelection: #sb)
ini (0 @ twoThirds extent: 1 @ third)
borderWidth: 1.
topView controller open!

```

```

instrumentName
^instrumentName:

```

```

myIn
^myIn:

```

```

myIn: #boolean
| pb |
self changeRequest iffFalse: [^self changed: #myIn].
myIn == self myIn not.
self changed: #myIn.
#boolean isNil iffTrue: [^nil].
(pb == self getSelectedParameter) isNil
iffTrue: [^nil]
iffFalse: [pb in: myIn]:

```

```

myOut
^myOut:

```

```

myOut: #boolean

```

```

| pb |
self changeRequest iffFalse: [^self changed: #myOut].
myOut == self myOut not.
self changed: #myOut.
#boolean isNil iffTrue: [^nil].
(pb == self getSelectedParameter) isNil
iffTrue: [^nil]
iffFalse: [pb out: myOut]:

```

```

sb
^sb:

```

```

sc
^sc:

```

```

sp
^sp:

```

```

sType
^sType:

```

```

sType: #

```

/usr0/jhaskar/Synthesizer.at last modified Sep 12 10:12 1985 Page 10

```

aView: a
  aView _a!
  {Generator methodsFor: 'displayBind'!
bindList
  ^ bindList values assortedCollectant
bindMenu
  ^ActionMenu
  labels: 'modify code\delete\clear\inspect' withCRs
  lines: #()
  selectors: #(modifyCode deleteBind clearBindList inspectBindList)!
clearBindList
  bindList _ Dictionary new.
  sb _ nil.
  self changed: #wakeBind!
deleteBind
  sb isNil ifTrue: [self notify: 'select a binding'.
  nil].
  bindList removeKey: sb ifAbsent: [self notify: 'cant find it'].
  sb _ nil.
getBindList
  ^bindList!
inspectBindList
  bindList inspect!
selectedBinding
  -
  sb isNil ifTrue: [self notify: 'must select a binding first'.
  nil].
  ^bindList at: sb!
wakeBind: aSelection
  sb _ aSelection!
-----
Generator class
  instanceVariableNames: ''!
  Generator class comment:
  'Generator class messages and variables are used
  to keep track of the lists of generators and instruments
  class variables
  GeneratorList
  SelectedGenerator
  InstrumentList
  SelectedInstrument

```

/usr0/bhubner/Syntholizer.st last modified Sep 12 10:12 1985 Page 11

```

!Generator class methods for 'class initialization'
addGenerator: aName
    adds the Generator aName into the GeneratorList
    must be followed by a call to compileGenerator: newName

    | newName |
    self changeRequest ifFalse: (self changed: #wakeGenerators).
    newName aName asSymbol.
    (aName at: 1) isLowercase
    ifTrue: [self error: 'Instrument Name Must begin with upper case ', aName.
             nil].
    GeneratorList at: newName put: (Generator new: newName).
    self changed: #wakeGenerators!

addGeneratorSpec: aClass parameters: aList
    used by Generator on startup
    to add basic generator classes with parameters
    to GeneratorList

    | aC |
    self addGenerator: aClass.
    aC _GeneratorList at: aClass.
    aList do: [:para | aC addParameterToList: para].
    self compileGenerator: aClass!

compileGenerator: aName
    called by addGenerator
    assume generator exists in GeneratorList
    and doesn't exist in System Dictionary

    | generatorBlok newClass |
    generatorBlok _GeneratorList at: aName
    ifAbsent: [self notify: 'cant find generator name ', aName.
             nil].

    " IndexOf is too slow
    (Smalltalk classNames indexOf: aName asSymbol)
    == 0 ifFalse: [self confirm: 'do you really want to recompile class ',
    aName] ifTrue:
    [self notify: 'ok'.
     nil].

    Transcript cr: show: 'adding generator ', aName.
    newClass _VirtualInstruments
    subclass: aName
    instanceVariableNames: ''
    classVariableNames: ''
    poolDictionaries: ''
    category: 'myInstruments'.
    newClass isNil ifTrue: [newClass _ Smalltalk at: aName ifAbsent: [self notify: 'cant find ', aName]].
    newClass zeroCounter.

    create methods for each parameter

```

./usr0/InuStar/Synthesizer.at last modified Sep 12 10:12 1985 Page 12

```

generatorDio: parameterList db: lin | generatorDio.mhParameterMessung p in; aName |
(newClass _Smalltalk at: aName ifAbsent: [self notify: 'can't find ', aName]) compile: 'runNo myValue = 1.D. self change(); #
myValue. #myValue' classified: 'parameters'
initializeList: myValue
| iCL date |
data _ (Date dateAndTimeNow at: 1) printString.
iCL _ OrderedCollection new.
iCL addLast: 'runNo'.
iCL addLast: 't'.
iCL addLast: 'myName'.
iCL addLast: 'date'.
- It would be nice to install messages to set
output parameters at this point
(see code in fix codeParameters) in form
self opara: self opara.

```

AICL

initialize

do the following once  
for class initialization  
Generator initialize

```

t | Time
t _ Time
millisecondsToRun:
[instrumentList _ Dictionary new.
SelectedInstrument _ nil.
GeneratorList _ Dictionary new.
SelectedGenerator _ nil.
TypeList _ #(number voltage frequency range function linearMeter logMeter).
ViewList _ #(linearGraph logGraph list linearMeter logMeter).
Generator addGeneratorSpec: adder parameters: #(left right output).
Generator addGeneratorSpec: Subber parameters: #(left right output).
Generator addGeneratorSpec: Multiplier parameters: #(left right output).
Generator addGeneratorSpec: divider parameters: #(numerator denominator output).
Generator addGeneratorSpec: LegitMer parameters: #(input output).
Generator addGeneratorSpec: FunctionGenerator parameters: #(function amplitude frequency).
Generator addGeneratorSpec: BMM parameters: #(function range measuredValue uncertainty)].
Transcript cr: shows (t / 1000) printString.
self displayGenerators!

```

new: aName

Asuper new initialize: aName!

newInstance

used by Generator list display yellow button menu  
to create a new instance of the selected Generator.

SelectedGenerator isNil ifTrue: [self notify: 'must select a Generator' first].  
self addInstrument: SelectedGenerator.  
(Smalltalk at: SelectedGenerator) new display!

```

/usr/lib/hunkar/Synthosizer.at last modified Sep 12 11:12 1995 Page 13

```

```

SelectedSynthesizer
Returns the object (not the name) representing
the Generator currently being synthesized.
Invoked from VirtualInstruments class in generate message

SelectedSynthesizer isn't
  if True:
    [self notify: 'please select a generator for synthesis'.
     nil]
  if False: [^GeneratorList at: SelectedSynthesizer!]

!Generator class methodsFor: 'displayGenerators':
addGenerator
  | newName |
  self changeRequest ifFalse: [self error].
  self addGenerator: (newName_ (FillInTheBlank request: 'add generator named ' initialAnswer: 'NouvelInstrument') asSymbol)).
  self compileGenerator: newName;

```

```

codeList #self selectedGenerator codeList;
deleteGenerator
  | s |
  self changeRequest ifFalse: [self changed: #wakeGenerators].
  s = SelectedGenerator.
  (self confirm: 'really delete ' , s , '?')
  ifFalse: [self].
  Transcript cr: show: remove , s.
  GeneratorList removeKey: s ifAbsent: [self notify: 'cant find ' , s].
  self changed: #wakeGenerators.
  [SelfTalk at: s] removeFromSystem.
displayGenerators

```

/usr0/dhaskar/Synthesizer.et last modified Sep 12 10:12 1985 Page 14

```

Generator displayGenerators
-
| pl topView |
topView _ StandardSystemView
    model: Generator
    label: 'Generator list'
    minimumSize: 150 e 200.
topView
    addSubView: (SelectionInListView
on: Generator
printItems: false
oneItem: false
aspect: #wakeGenerators
change: #wakeGenerators
list: #listGenerators
menu: #generatorMenu
initialSelection: nil)
in: (0 e 0 extent: 1 e 1)
borderWidth: 1.
topView controller open:
generatorMenu
    ^ ActionMenu
        labels: 'new instance\synthesize\add\delete\clone\inspect Me' withCra
        lines: # (2 4)
        selectors: # (addInstrument synthesis addGenerator deleteGenerator inspectSelectedGenerator )
inspectSelectedGenerator
-
self selectedGenerator inspect:
listGenerators
    ^GeneratorList keys asSortedCollection:
selectedGenerator
    ^GeneratorList at: SelectedGenerator
ifAbsent:
    [self notify: 'selected generator ', SelectedGenerator, ' not found', GeneratorList inspect.
    nil];
selectedSynthesizer
    ^GeneratorList at: SelectedSynthesizer
ifAbsent:
    [GeneratorList notify: 'selected Synthesizer ', SelectedSynthesizer, ' not found'.
    GeneratorList inspect.
    nil];
synthesis
    SelectedGenerator isNil ifTrue: [self notify: 'cant syn sans selection'].
    GeneratorList at: SelectedGenerator ifAbsent: [self].
    SelectedSynthesizer SelectedGenerator.
    (GeneratorList at: SelectedGenerator) displaySynthesis:
wakeGenerators: #String

```

```

/usr0/ihshar/Synthesizer.at last modified Sep 12 10:12 1985 Page 15

```

```

example
-
Generator initialize must be done once
to initialize class variables
-
Generator displayGenerators.
Generator displayInstruments: !
(Generator class methodsFor: 'displayInstruments'!
addInstrument
used by display instrument and generator yellow button menus
to create and add new instrument to instrument list.
-
SelectedGenerator isNil
ifTrue: [self notify: 'must select a generator!'.
GeneratorList inspect].
Generator addInstrument: SelectedGenerator!
addInstrument: className
given a class named className
creates a new instrument instance newInstance named aName
and shoves it into class variable instrument list.
-
|i aName newInstance aClass p |
self changeRequest ifFalse: [self changed: #wakeInstruments].
(className at: 1) isVowel
ifTrue: { '-an' }
ifFalse: { '-a' }.
aClass _ Smalltalk at: className.
aName _ 1 . className , aClass classCounterIncrement printString.
newInstance _ aClass new: aName parameters: (p _ Generator selectedGenerator getParameters).
instrumentList at: aName put: newInstance.
self changed: #wakeInstruments.
newInstance display!
deleteInstrument
| s |
self changeRequest ifFalse: [self changed: #wakeInstruments].
a SelectedInstrument
(self confirm 'really delete ' , s . '?)
ifFalse: [self].
InstrumentList removeKey: a ifAbsent: [self notify: 'cant find ' , s].
self changed: #wakeInstruments!
displayInstruments
used to view list of currently available
instrument names.
Generator displayInstruments
-
| topView i |
i _ Generator.
.....

```

/usr0/bhaskar/Synthesizer.st last modified Sep 12 10:12 1985 Page 16

```

topView
addSubview: (SelectionInListView
on: i)
printItems: false
oneItem: false
aspect: #wakeInstruments
change: #wakeInstruments
list: #listInstruments
menu: #instrumentMenu
initialSelection: nil)
in: (0 @ 0 extent: 1 @ 1)
borderWidth: 1.
topView controller open!

generateSelectedInstrument
{ t |
InstrumentList at: SelectedInstrument ifAbsent: [ InstrumentList inspect]] generate.!

inspectInstrument
^InstrumentList inspect!

InstrumentList
^InstrumentList!

InstrumentMenu
^ ActionMenu

labels: #show me\run me\generate\add\delete\inspect Me\ withCRs
lines: #( 3)
selectors: #(showSelectedInstrument runSelectedInstrument generateSelectedInstrument addInstrument delete
Instrument inspectInstrument)

listInstruments
^InstrumentList keys asSortedCollection!

runSelectedInstrument
(Generator selectedInstrument) runMe; changed: #metreValue!

selectedInstrument
^InstrumentList at: SelectedInstrument
ifAbsent: [InstrumentList notify: 'selected instrument '. SelectedInstrument. ' not found'. InstrumentList inspect-
nil]!

showSelectedInstrument
{ t |
InstrumentList at: SelectedInstrument ifAbsent: [ InstrumentList inspect]] display.!

wakeInstruments: aSelection
SelectedInstrument _ aSelection!

!Generator class methodsFor: 'synthesis'.

InitCode
{ t |
^ t _ (GeneratorList at: SelectedGenerator
ifAbsent: [self notify: 'init'.

```

/usr0/unasker/Synthesizer.st last modified Sep 12 10:12 1985 Page 17

```

ifAbsent:
    [self notify: 'init'.
     nil] stype;

initWith ^ (GeneratorList at: SelectedGenerator
ifAbsent:
    [self notify: 'init'.
     nil]) sView;

inspectInstance
(generatorList at: SelectedSynthesizer if sent:[self notify: 'select']) inspect;

inspectMe
self inspect;

typeList ^TypeList asSortedCollection;

typeMenu "
-
^ActionMenu
labels: 'inspect class\inspect tance' withCRS
lines: #()
selectors: #(inspectMe inspect: tance );

viewList ^ViewList asSortedCollection;

wakeType: s
| pb |
s nil ifTrue: [nil].
self selectedGenerator stype: s.
(pb _ self SelectedSynthesizer GetSel.
 ifTrue: [nil]
 ifFalse:
    [pb type: s.
     self changed: #wakePa eter]);

wakeView: s
| pb |
s nil ifTrue: [nil].
self selectedGenerator sView: s.
(pb _ self SelectedSynthesizer GetSe.
 ifTrue: [nil]
 ifFalse:
    [pb view: s.
     self changed: #wakeP .meter]);

Generator Initialize;

```



/usr0/bhaskar/Synthesizer.st last modified Sep 12 10:12 1985 Page 19

!ParameterBlok class methodsfor: 'create'!

```
new
  | t |
  t_ super new deepCopy.
  ^t!
```

/usrD/haskell/Synthesizer.at last modified Sep 12 10:12 1985 page 40

```

Number variableSubclass: #VirtualInstruments
InstanceVariableNames: myName myParameters selectedP myType myIn myOut myView myValue myKounter myKode
ClassVariableNames: ClassParameterList Kounter QuadKounter
poolDictionaries:
  Category: Synthesizer
VirtualInstruments comment
This class provides common display
messages for the instrument classes created
by the Generators.

```

```
!VirtualInstruments methodsFor: 'displayList'!
```

```
listMetre: aBlok
```

```
used by VirtualInstruments display
for choices
"
```

```

| newMenu pName wake |
newMenu _self listMetreMenu: aBlok.
pName _aBlok name asSymbol.
wake _ (pName . :) asSymbol.
^SelectionInListView
on: self
onItems: false
aspect: pName
change: wake
list: pName
menu: newMenu
initialSelection: nil

```

```
listMetreMenu: aBlok
| t is ||
| is _square\sina\triangle' withCRs.
is _#(inspectMe inspectMe inspectMe ).
t _ActionMenu
labels: ||
lines: #(3)
selectors: is.

```

```
at: t
```

```
!VirtualInstruments methodsFor: 'displayMeter'!
```

```
display "
```

```
displays an instantiated instruments' values
in meter views
```

```

| ak mySize nP height topView myMetre pView |
ak 0.
mySize 100.
nP myParameters size.
height nP * mySize.
topView _StandardSystemView
model: self
label: myName
minimumSize: mySize * (height * 0.8).

```

```

/usr0/uhukur/Syntholizer.st last modified Sep 12 10:12 1985 page x:

    ifTrue: [myMetre _ self listMetre: ap]
    ifFalse: [myMetre _ self parameterMetre: ap].
myMetre
    isH:
    ifTrue: [self notify: 'nil metre']
    ifFalse: [topView
        addSubView: myMetre
            in: (0 @ (xk / np) extent: 1 @ (1 / np))
            borderWidth: 1.].
xk _ xk + 1).
topView controller open!
parameterMetre: pBlock
"
| myScale myMetre pName resultName pValue range bottom pUM |
pName _ pBlock name.
pValue _ pBlock value.
range _ 10.0.
pBlock view == #logMeter | (pBlock view == #logGraph)
    ifTrue: [myScale _ LogScale new.
        bottom _ 1.0]
    ifFalse: [myScale _ LinScale new.
        bottom _ 0.0]
pBlock view == #linearGraph | (pBlock view == #logGraph)
    ifTrue: [myMetre _ BarGraphView withScale: myScale]
    ifFalse: [myMetre _ PanelMeterView withScale: myScale].
myMetre itemName: pName; minValue: bottom; maxValue: range.
myMetre instanceColor: Form white.
myMetre model: self.
myMetre controller: MeterController new.
myMetre controller newValueSymbol: #newValue.
myMetre updateSymbol: #metreValue.
myMetre valueAccessSymbol: pName.
" check for output in pBlock; dont change outputs"
(pBlock out and: [pBlock in not])
    ifTrue: [resultName _ #fake]
    ifFalse: [resultName _ (pName . '.') asSymbol].
myMetre valueChangeSymbol: resultName.
" build labels & message list on the fly -- do your own setValue" pUM _ ('generate/run/stop/inspect me\set ', pName) withCRs.
myMetre controller yellowButtonMenu: (popupMenu labels: pUM)
yellowButtonMessages: (self makeYBM; pName).
myMetre!

!VirtualInstruments methodsFor: 'private'
fake: x
"
kludge used by instrument display
to prevent output meters
from being changed from front panel
"
self notify: 'fake'!

generate
"
should send Smalltalk code to
SelectedGenerator underSynthesis

```

/usr0/llnusr/Synthesizer.at lab1 modified Sep 12 10:12 1985 Page 22

```

| target pName pVal s tp tt quad quadList Index {
target Generator SelectedSynthesizer.
target TANI
ifTrue:
    [self notify: 'select a generator'.
     ^self].
emit small talk code into an ordered list
target insertCode: t (Generator InstrumentList) at: . myName printString . . .
myParameters do: [:ap | ap in
ifTrue:
    [pName _ ap name printString.
     _take value from instance: ".
     pVal _ (self perform: pName asSymbol) printString.
     s _ t . pName . ; . pVal . . . .
     target insertCode: s]].

set up unique quad names here.
declaring temps after fact is a pain
quad VirtualInstruments nextQuad.
target insertCode: quad . t runfile.
target getBindList at: quad Out: quad.
quadList target codeList at: 2.
quadList isEmpty
ifTrue:
    [self notify: 'empty quad list'.
     ^nil].
index quadList indexOf: $I.
quadList copyReplaceFrom: index + 1
to: index + 1
with: . . . quad . . .
target codeList at: 2 put: quadList.
target changed: #sketchcode.
add my parameters to the bind list
myParameters do: [:ap | (tt _ ap out)
ifTrue:
    [pName _ ap name printString.
     target getBindList at: myName . pName put: ((Generator InstrumentList) at: . . . . myName . . . .) . pName]]

initialize: aName

| temp |
myName _ aName.
quadCounter _ 0.

inspectMy
self inspect:
makeYUM: pName

```

```

/usr0/bhaskar/Syntholizer.el lout multi.tcl Sep 12 10:12 1995 Page 23

```

```

myParameters; and
myParameters _ and;

myValue myValue isNil ifTrue: [myValue _ 1].
myValue;
myValue; aValue
default class instance message to set
computed instrument value
myValue _ aValue;

run
used by an instruments yellow button menu
to update result

| t |
t _ self runMe.
self changed: #metreValue.!

setValue _
value should come from parameter via ??? value, not instrument
and go back to instrument via ??? value; value

| value |
value fillInTheBlank request: 'new value' initialAnswer: myValue printString.
myValue _ value asNumber.
self changed: #wakeMetre.
self notify: 'new value' . value printString;

stopMe
stops my dependents

self dependents notify: 'stopMe'.
self changed!;

-----
VirtualInstruments class
instanceVariableNames: ''

!VirtualInstruments class methodsFor: 'initialize';
new: #Name parameters: parameterBlock
used by Generator instantiate messages
to create a new instance of an instrument
and initialize it with a name and parameter block
{ instance |

```

```
!VirtualInstruments class methodsfor: 'action'!
```

```
classKounterIncrement
```

```
    ^Kounter _ Kounter + 1!
```

```
nextQuad
```

```
    QuadKounter isNil ifTrue: [QuadKounter _ 0].
```

```
    ^ 'q'. (QuadKounter _ QuadKounter + 1) printString!
```

```
resetQuad
```

```
    ^ QuadKounter _ 0!
```

```
zeroKounter
```

```
    Kounter _ 0! !
```

## APPENDIX III

/usr0/bhaskar/Interface-Meters.st last modified Sep 12 10:17 1985 Page 1

```

MeterController subclass: #MeterController
  instanceVariableNames: 'newValueSymbol'
  classVariableNames: ''
  poolDictionaries: ''
  category: 'Interface-Meters'

!MeterController methodsFor: 'control activity'
  controlActivity
    "tell view when user has a new value by pressing and releasing red button"

    | currentMousePoint saveMousePoint |
    saveMousePoint nil.
    [ sensor redButtonPressed & self viewHasCursor ] whileTrue:
      [ currentMousePoint = sensor mousePoint.
        (( saveMousePoint = currentMousePoint ) not ) ifTrue:
          [ saveMousePoint currentMousePoint.
            view perform: newValueSymbol with: currentMousePoint ]].
      super controlActivity!

isControlActive
  ^super isControlActive & sensor blueButtonPressed not!

!MeterController methodsFor: 'view interface'
  newValueSymbol
    "tells what symbol will be used send view with new value"
    ^newValueSymbol

  newValueSymbol: aSymbol
    "tells what symbol will be used send view with new value"
    newValueSymbol = aSymbol.
    ^self!

!MeterController methodsFor: 'menu messages'
  menuMessageReceiver
    "Answer the object that should be sent a message when a menu item is selected."
    ^ self model!

!MeterController methodsFor: 'menu setup'
  redButtonMenu: aSystemMenu redButtonMessages: anArray
    ^self error: 'MeterController does not support red button menus'!

```

/usr0/bhaskar/interface-meters.st last modified Sep 12 10.17 1995 Page 2

```

Object subclass: #MeterScale
  instanceVariableNames: 'maxScale maxValue minScale minValue'
  classVariableNames: ''
  poolDictionaries: ''
  category: 'Interface-Meters.'

!MeterScale methodsFor: 'conversion'!
scaleToValue: aScale
  ^self subclassResponsibility!

valueToScale: aValue
  ^self subclassResponsibility!

!MeterScale methodsFor: 'private'!
resetConstant
  ^self subclassResponsibility!

!MeterScale methodsFor: 'limits'!
maxScale ^maxScale!

maxScale: aNumber
  maxScale _ aNumber.
  self resetConstant.
  ^self!

maxValue ^maxValue!

minScale: aNumber
  minScale _ aNumber.
  self resetConstant.
  ^self!

minScale ^minScale!

minScale: aNumber
  minScale _ aNumber.
  self resetConstant.
  ^self!

minValue ^minValue!

minValue: aNumber
  minScale _ aNumber.
  self resetConstant.
  ^self!

```

```
MeterScale subclass: #LinScale
instanceVariableNames: 'conversionConstant'
classVariableNames: ''
poolDictionaries: ''
category: 'Interface-Meters'
```

```
!LinScale methodsFor: 'conversion'
```

```
scaleToValue: aScale
    ^minValue + ((aScale - minScale) / self conversionConstant)
```

```
valueToScale: aValue
    aValue = nil ifTrue: [ ^minScale ]
    ifFalse: [ ^minScale + ((aValue - minValue) * self conversionConstant)] !
```

```
!LinScale methodsFor: 'private'
```

```
conversionConstant
    (conversionConstant = nil)
    ifTrue: [ ^conversionConstant ( maxScale - minScale ) / ( maxValue - minValue ) ]
    ifFalse: [ ^conversionConstant ] !
```

```
resetConstant
    conversionConstant _ nil.
    ^self !
```

/usrU/bhuskar/Interface-Meters.st last modified Sep 12 10:17 1985 Page 4

```

MeterScale subclass: #LogScale
  instanceVariableNames: 'conversionConstant lnMinValue'
  classVariableNames: ''
  poolDictionaries: ''
  category: 'Interface-Meters'

!LogScale methodsFor: 'private'

conversionConstant
  (conversionConstant = nil)
  ifTrue: [ ^conversionConstant (maxScale - minScale) / ((maxValue / minValue) ln) ]
  ifFalse: [ ^conversionConstant ];

resetConstant
  conversionConstant = nil.
  ^self ;

!LogScale methodsFor: 'limits'

maxValue: aNumber
  aNumber > 0
  ifTrue:
    [maxValue = aNumber.
     self resetConstant.
     ^self]
  ifFalse: [^self error: 'LogScale can't handle negative numbers'];

minValue: aNumber
  aNumber > 0
  ifTrue:
    [lnMinValue = (minValue - aNumber) ln.
     self resetConstant.
     ^self]
  ifFalse: [^self error: 'LogScale can't handle negative numbers'];

!LogScale methodsFor: 'conversion'

scaleToValue: aScale
  ^((lnMinValue + ((aScale - minScale) / self conversionConstant)) exp)

valueToScale: aValue
  aValue = nil
  ifTrue: [^minScale]
  ifFalse: [aValue > 0
    ifTrue: [^ minScale + (aValue ln - lnMinValue * self conversionConstant)]
    ifFalse: [^ minScale]];

```

Z:\mrd\muhkhar\interface-Meters.st last modified Sep 12 10:17 1985 Page 5

```

View subclass: MeterView
  instanceNameNames: 'cachedBox cachedForm center currentValue itemNum minValue maxValue myProduct myScale myRadius myInitData
  myDictionaryNames:
  category: 'Interface-Meters'

!MeterView methodsFor: 'initialize-release'
  initialize
    super initialize.
    myProject := Project current.
    pen := Pen new.
    ^self forceFullDisplayNextTime!

  itemName: aString
    itemName := aString asText.
    itemName emphasizeFrom: 1 to: itemName size with: 9.
    itemName := itemName asDisplayText.
    ^self forceFullDisplayNextTime!

  maxValue ^maxValue:
  minValue ^minValue:
  scale ^myScale:

  scale: aScale
    myScale := aScale.
    ^self!

!MeterView methodsFor: 'displaying'
  display myProject as Project current
    ifTrue: [super display]!

!MeterView methodsFor: 'private'
  forceFullDisplayNextTime
    "forces next display of the view to be full redisplay (cached image not used)"
    cachedBox := nil.
    ^self!

!MeterView methodsFor: 'model access'
  valueAccessSymbol: aSymbol
    "this sets the value of valueAccess to be the message sent to the model to get the value of current value"
    valueAccess := aSymbol.

```

/usr0/bmskar/interface-Meters.st last modified Sep 12 10:17 1985 Page 6

```

valueChange
    "tell model that I have a new value, then update self , but access the new currentValue from the model!"
    model perform: valueChange with: currentValue.
    self update: "updateOn!"

valueChangeSymbol: aSymbol
    "this sets the value of valueChange to be the message sent to the model to get the value of current value"
    valueChange _ aSymbol.
    ^self !

!MeterView methodsFor: 'updating'!
update: selfOrSymbol
    "this is used to force an update by sending appropriate values in selfOrSymbol"
    ( selfOrSymbol == self ) ifTrue: [ self display ].
    ( selfOrSymbol == updateOn ) ifTrue: [ self valueFromModel display ]!

updateSymbol: aSymbol
    "this sets the symbol, which, if broadcast, will cause me to redisplay myself"
    updateOn _ aSymbol.
    ^self !

valueFromModel
    "this is used to get a value from the model"
    currentValue > model perform: valueAccess.
    currentValue < self maxValue ifTrue: [currentValue > 0
        ifTrue: [self maxValue: (10 raisedTo: (currentValue * 1.2 log: 10) ceiling)]
        ifFalse: [self maxValue: (10 raisedTo: (currentValue negated * 0.8 log: 10) floor) negated]].
    currentValue < self minValue ifTrue: [currentValue > 0
        ifTrue: [self minValue: (10 raisedTo: (currentValue * 0.8 log: 10) floor)]
        ifFalse: [self minValue: (10 raisedTo: (currentValue negated * 1.2 log: 10) ceiling) negated]]!

---
!MeterView class
instanceVariableNames: '';

!MeterView class methodsFor: 'instance creation'!
withScale: aScale
    | aMeter |
    aMeter self new scale: aScale.
    aMeter. ThisScale.
    ^aMeter !

```

user0\shaskar\Interface-Meters.et last modified Sep 12 10:17 1985 Page 7

```

MeterView subclass: #BarGraphView
  instanceVariableNames: 'barOrigin bary'
  classVariableNames:
  poolDictionaries: ''
  category: 'Interface-Meters'

```

```

!BarGraphView methodsFor: 'displaying'
  displayView
    "how to draw a picture of me"

```

```

    { selfInsetDisplayBox extent: itemPosition temp minValuePosition maxValuePosition currentValuePosition |
      selfInsetDisplayBox self insetDisplayBox.
      currentValue = nil. ifTrue: [self valueFromModel].
      self topView isCollapsed
    ifFalse:

```

```

      ifFalse: {(cachedBox == nil) or: (cachedBox == selfInsetDisplayBox)}
      ifTrue:

```

```

        {extent _ selfInsetDisplayBox extent.
         barOrigin _ selfInsetDisplayBox origin + selfInsetDisplayBox leftCenter / 2.
         bary _ selfInsetDisplayBox extent y / 2.
         myScale maxScale: extent x.
         itemPosition _ selfInsetDisplayBox corner.
         itemName displayOn: Display
           at: selfInsetDisplayBox topLeft
           clippingBox: selfInsetDisplayBox.
         temp _ minValue printString asDisplayText.
         minValuePosition _ selfInsetDisplayBox bottomLeft - (0 * temp boundingBox height).
         temp
           displayOn: Display
             at: minValuePosition
             clippingBox: selfInsetDisplayBox.
         temp _ maxValue printString asDisplayText.
         maxValuePosition _ selfInsetDisplayBox corner - temp boundingBox extent.
         temp
           displayOn: Display
             at: maxValuePosition
             clippingBox: selfInsetDisplayBox.
         cachedForm _ Form fromDisplay: (cachedBox _ selfInsetDisplayBox)
           displayAt: selfInsetDisplayBox topLeft.

```

```

        Display
          fill: (rectangle origin: barOrigin extent: (myScale valueToScale: currentValue) rounded * bary)
          rule: Form under
            mask: Form veryLightGray.
        temp _ currentValue printString asText.
        temp
          emphasiseFrom: 1
            to: temp size
            with: 17.
        temp _ temp asDisplayText.
        currentValuePosition _ selfInsetDisplayBox center - (0.5 * temp boundingBox extent).
        temp
          displayOn: Display
            at: currentValuePosition
            clippingBox: selfInsetDisplayBox.

```

```

!BarGraphView methodsFor: 'controller interface'

```

```
/usr0/blaskar/Interface-Meters.st last modified Sep 12 10:17 1985 Page 8

    currentValue _myScale scaleToValue: aPoint x - self inputDisplayBox left.
    self valueChange!

!BarGraphView methodsFor: 'initialize-release'

initScale
    myScale minScale: 0.
    ^self!
```

/usr/D/uhuskar/Interface-Meters.st last modified Sep-12 10:17 1985 Page 4

```

MeterView subclass, #panelMeterView
instanceVariableNames, ''
classVariableNames, ''
poolDictionaries, ''
category: 'Interface-Meters'

!PanelMeterView methodsFor: 'initialize-release'
initScale
    myScale minScale: -90, maxScale: 90.
    ^self!

!PanelMeterView methodsFor: 'displaying'
displayView
    "how to draw a picture of me"
    | extent circle selfInsetDisplayBox temp minValuePosition maxValuePosition currentValue itemPosition |
    selfInsetDisplayBox self insetDisplayBox.
    currentValue = nil ifTrue: [self valueFromModel].
    self topView isCollapsed
    ifFalse:
        [(cachedBox = nil or: [cachedBox --w selfInsetDisplayBox])
         ifTrue:
             [extent _ selfInsetDisplayBox extent.
              center _ selfInsetDisplayBox bottomCenter + selfInsetDisplayBox: center / 2.
              radius _ selfInsetDisplayBox width / 2 * 0.9.
              (Arc new)
                  center: 0 @ 0
                  radius: radius
                  quadrant: 1
                  displayOn: display
                  at: center
                  clippingBox: selfInsetDisplayBox: quadrant: 2;
                  displayOn: display
                  at: center
                  clippingBox: selfInsetDisplayBox.
              itemNamePosition _ selfInsetDisplayBox corner.
              itemNamePosition display
                  at: selfInsetDisplayBox topLeft
                  clippingBox: selfInsetDisplayBox.
              pen defaultNib: 1; north; turn: -90.
              11 timesRepeat: [pen place: center; up: 90; radius + 0.9; down: 90; radius + 0.1; turn: 180].
              temp _ minValue printString asDisplayText.
              minValuePairPosition _ selfInsetDisplayBox bottomLeft - (0 @ temp boundingBox height).
              temp
                  displayOn: display
                  at: minValuePairPosition
                  clippingBox: selfInsetDisplayBox.
              temp _ maxValue printString asDisplayText.
              maxValuePairPosition _ selfInsetDisplayBox corner - temp boundingBox extent.
              temp
                  displayOn: display
                  at: maxValuePairPosition
                  clippingBox: selfInsetDisplayBox.
              cachedForm Form fromDisplay: [cachedBox selfInsetDisplayBox]
              pen defaultNib: 2; place:center; north; turn: [myScale valueToScale: currentValue]; down; go; radius.
              temp _ currentValue printString asText.

```

/usr0/uhaskar/Interface-Meters.st last modified Sep 12 10:17 1985 Page 10

```

with: 17.
temp _temp asDisplayText.
currentValuePosition _selfInsetDisplayBox center - (0.5 * temp boundingBox extent).
temp
displayOn: Display
at: currentValuePosition
clippingBox: selfInsetDisplayBox];

```

!PanelMeterView methodsfor: 'controller interface':

```

newValue: aPoint
"sent to me by MeterController to tell me that the user has pressed
red button on a point"
| angle. |
aPoint y > center y
iffalse:
    [aPoint x - center x = 0
    iffTrue: [angle _ 90]
    iffalse:
        [angle _ (center y - aPoint y / (aPoint x - center x)) arcTan radfanstoDegrees.
        angle < 0 iffTrue: [angle _ 180 + angle]].
    currentValue _myScale scaleToValue: (90 - angle).
    self valueChange];

```

We claim:

**[1.** An instrumentation system comprising:

a computer;

a plurality of instruments selectively controlled by input data and producing output data;

bus means connecting said instruments to said computer for conveying input data and output data to and from selected instruments;

a screen controlled by, said computer; and

software controlling operation of said computer implementing a plurality of virtual machines each comprising a set of computer instructions, said virtual machines being associated with respective ones of said instruments for providing input thereto or receiving output therefrom, a virtual machine controlling display on said screen of a virtual front panel depicting an instrument and able to display a representation of data associated with an instrument represented by a virtual front panel; said software further comprising:

software responsive to operator input for enabling a selection of ones of said virtual front panels,

said computer being responsive to said selection for generating a new virtual machine comprising a combined set of the computer instructions which comprises the virtual machines associated with the selection of ones of said virtual front panels, said new virtual machine controlling display of a new virtual front panel on said screen including representation of values conveyed on said bus with respect to instruments represented by said selection of ones of said virtual front panels,

said new virtual machine initiating transmission of input data to one of said instruments in response to changes in values of input data represented by said new virtual front panel and for portraying an output data value as represented by the new virtual front panel in response to output data received from another one of said instruments.]

**[2.** An instrumentation system for carrying out a procedure with respect to equipment being tested by the instrumentation system, comprising:

a computer;

bus means coupled to said computer wherein said bus means carries data to and from said computer;

instrumentation also coupled to said bus means, at least a portion of said instrumentation receiving data from said computer via said bus means and at least a portion of said instrumentation supplying data to said computer via said bus means;

means for coupling at least a portion of said instrumentation to equipment under test; and

a screen controlled by said computer;

wherein said computer is controlled by software for displaying on said screen at least one virtual front panel representing at least a said portion of said instrumentation, wherein said software implements a first virtual machine comprising a first set of computer instructions corresponding to a said at least one virtual front panel for controlling coupling of data with a said portion of said instrumentation;

wherein said software provides at least one second virtual machine comprising a second set of computer instructions for bringing about performance of a computer operation as well as display on said screen of another virtual front panel representing a said computer operation; and

wherein said software is operable in response to operator designation of virtual machines by selection of front panels to generate a combined instruction set from said first and second instruction sets which provides a further front panel, said combined instruction set conjointly controlling said instrumentation for carrying out said procedure.]

**[3.** An instrumentation system comprising:

a computer;

an instrument;

bus means connecting the instrument to the computer to provide data interchange therebetween;

a screen controlled by said computer;

means conveying user input including input commands to said computer; and

memory means storing software in execution by said computer implementing a collection of virtual machines, each virtual machine of said collection of virtual machines comprising a set of instructions, said collection of virtual machines including:

a first virtual machine responsive to data on said bus means and displaying on said screen a first virtual front panel representing said instrument; and

a plurality of second virtual machines, each producing designated operation output data in response to operation input data, and displaying a separate second virtual front panel on said screen, wherein said first and second virtual machines respond to input commands by generating output computer instructions corresponding to the sets of instructions of said first and second virtual machine;

said software further implementing software generation responding to user input selecting ones of said virtual machines by combining the output computer instructions generated by said first and second virtual machines in response to input commands to form new software implementing a third virtual machine performing operations corresponding to the operations of selected first and second virtual machines.]

**[4.** The system in accordance with claim 3 wherein at least one of said first, second and third virtual front panels displays an input data value and wherein a virtual machine controlling said at least one virtual front panel comprises means for providing input to said software for adjusting said input data value in response to user input.]

**[5.** For an instrumentation system comprising a computer, an instrument, bus means connecting the instrument to the computer, a screen controlled by said computer, and means conveying user input including input commands to said computer, a method for controlling said instrument and displaying values relating thereto, the method comprising the steps of:

executing software implementing a first virtual machine comprising a first set of computer instructions corresponding to said instrument and displaying on said screen a first virtual front panel representing said instrument, and implementing a plurality of second virtual machines comprising second sets of computer instructions, each for producing operation output data in response to operation input data and displaying a second virtual front panel on said screen representing an operation controlled by the second virtual machine, wherein said first and second virtual machines respond to input commands for selecting said first and second virtual machines by generating output computer instructions representative of the respective instruction sets of the selected first and second virtual machines;

transmitting said input commands to said software pertaining to ones of said first and second virtual machines selected in response to user input;  
 combining output computer instructions generated by said ones of said first and second virtual machines in response to said input commands to form new software implementing a third virtual machine executing a sequence of operations synthesizing the operations of said first and second virtual machines selected in response to user input and displaying on said screen a third virtual front panel representing said third virtual machine, wherein said user input further defines the sources and destinations of input and output data for said first and second virtual machines as synthesized by said third virtual machine; and  
 executing said new software implementing said third virtual machine.]

[6. The method in accordance with claim 5 wherein said third virtual front panel displays at least one value of instrument output data and wherein the step of executing said new software comprises the step of adjustment of said instrument in response to user input.]

[7. An instrumentation system for conducting a procedure with respect to a device under test, comprising:

a computer;  
 a plurality of instruments adapted for coupling to said device under test; and  
 bus means connecting said instruments to said computer for providing data communication between said instruments and said computer;  
 said computer being controlled by software implementing a plurality of selectable virtual machines, said virtual machines being associated with said plurality of instruments, a said virtual machine comprising a set of instructions controlling a corresponding instrument and display on said screen of a corresponding virtual front panel;  
 said software further comprising:  
 software responsive to operator input for enabling selection of ones of said virtual front panels;  
 said computer being responsive to said selection for generating a new virtual machine, said new virtual machine controlling display of a new virtual front panel on said screen;  
 said new virtual machine initiating data transmission with ones of said instruments in response to operator interaction with said new virtual front panel.]

[8. An instrumentation system comprising:

computer means;  
 instrumentation which operates according to input data for producing output data;  
 bus means connecting the instrumentation to the computer means for carrying said input data from said computer means to said instrumentation and for carrying said output data from said instrumentation to said computer means; and  
 a screen controlled by said computer means;  
 wherein said computer means is controlled by software for displaying on said screen at least a first virtual front panel graphically depicting said instrumentation;  
 wherein said computer software implements a first virtual machine comprising a first set of computer instructions for controlling the receipt by said computer means via said bus means of said output data from said instrumentation and a second virtual machine comprising a second set of computer instructions for bringing about a computer operation;

said computer software controlling display on said screen of a second virtual front panel associated with said second virtual machine;  
 wherein said computer software implements operator controlled selection of ones of said first and second virtual machines to carry out a programmed process involving said instrumentation; and  
 wherein said computer software further implements synthesizing a new virtual machine wherein said new virtual machine is defined by the selected virtual machine and operator selected interrelationship between said selected virtual machines.]

9. An instrumentation system comprising:

computer means;  
 instrumentation which operates according to input data for producing output data;  
 bus means connecting the instrumentation to the computer means for carrying said input data from said computer means to said instrumentation and for carrying said output data from said instrumentation to said computer means; and  
 a screen controlled by said computer means;  
 wherein said computer means is controlled by software for displaying on said screen at least a first virtual front panel graphically depicting said instrumentation, wherein said first virtual front panel is associated with a first virtual machine;  
 wherein said computer software is operable to receive user input selecting a type of said first virtual front panel associated with said first virtual machine;  
 wherein said computer software implements said first virtual machine comprising a first set of computer instructions for controlling the receipt by said computer means via said bus means of said output data from said instrumentation and a second virtual machine comprising a second set of computer instructions for bringing about a computer operation;  
 said computer software controlling display on said screen of a second virtual front panel associated with said second virtual machine;  
 wherein said computer software implements operator controlled selection of ones of said first and second virtual machines to carry out a programmed process involving said instrumentation; and  
 wherein said computer software further implements synthesizing a new virtual machine wherein said new virtual machine is defined by the selected virtual machine and operator selected interrelationship between said selected virtual machines.

10. The instrumentation system of claim 9, wherein the type of the virtual front panel comprises at least one of: a bar graph, a meter, a logarithmic graph or meter, an alphanumeric readout, simulated lamps, or selector lists.

11. An instrumentation system comprising:

computer means;  
 instrumentation which operates according to input data for producing output data;  
 bus means connecting the instrumentation to the computer means for carrying said input data from said computer means to said instrumentation and for carrying said output data from said instrumentation to said computer means; and  
 a screen controlled by said computer means;  
 wherein said computer means is controlled by software for displaying on said screen at least a first virtual front panel graphically depicting said instrumentation;

wherein said computer software implements a first virtual machine comprising a first set of computer instructions for controlling the receipt by said computer means via said bus means of said output data from said instrumentation and a second virtual machine comprising a second set of computer instructions for bringing about a computer operation;

wherein the first virtual machine comprises at least one input parameter, wherein a type of the at least one input parameter is operable to be displayed on the screen;

said computer software controlling display on said screen of a second virtual front panel associated with said second virtual machine;

wherein said computer software implements operator controlled selection of ones of said first and second virtual machines to carry out a programmed process involving said instrumentation; and

wherein said computer software further implements synthesizing a new virtual machine wherein said new virtual machine is defined by the selected virtual machine and operator selected interrelationship between said selected virtual machines, wherein the computer software is operable to receive operator input specifying a desired parameter type for the at least one input parameter, wherein said received input is specified using a cursor, and wherein the input parameter is usable by the computer software to specify said interrelationship between said selected virtual machines.

12. The instrumentation system of claim 11, wherein the new virtual machine is configured to use the at least one input parameter.

13. An instrumentation system comprising:  
 computer means;  
 instrumentation which operates according to input data for producing output data;  
 bus means connecting the instrumentation to the computer means for carrying said input data from said computer means to said instrumentation and for carrying said output data from said instrumentation to said computer means; and  
 a screen controlled by said computer means;  
 wherein said computer means is controlled by software for displaying on said screen at least a first virtual front panel graphically depicting said instrumentation;  
 wherein said computer software implements a first virtual machine comprising a first set of computer instructions for controlling the receipt by said computer means via said bus means of said output data from said instrumentation and a second virtual machine comprising a second set of computer instructions for bringing about a computer operation;  
 wherein the first virtual machine comprises at least one output parameter, wherein a type of the at least one output parameter is operable to be displayed on the screen;  
 said computer software controlling display on said screen of a second virtual front panel associated with said second virtual machine;  
 wherein said computer software implements operator controlled selection of ones of said first and second virtual machines to carry out a programmed process involving said instrumentation; and  
 wherein said computer software further implements synthesizing a new virtual machine wherein said new virtual machine is defined by the selected virtual machine and operator selected interrelationship between said selected virtual machines, wherein the computer soft-

ware is operable to receive operator input specifying a desired parameter type for the at least one output parameter, wherein said received input is specified using a cursor, and wherein the output parameter is usable by the computer software to specify said interrelationship between said selected virtual machines.

14. The instrumentation system of claim 13, wherein the new virtual machine is configured to use the at least one output parameter.

15. An instrumentation system comprising:  
 computer means;  
 instrumentation which operates according to input data for producing output data;  
 bus means connecting the instrumentation to the computer means for carrying said input data from said computer means to said instrumentation and for carrying said output data from said instrumentation to said computer means; and  
 a screen controlled by said computer means;  
 wherein said computer means is controlled by software for displaying on said screen at least a first virtual front panel graphically depicting said instrumentation;  
 wherein said computer software implements a first virtual machine comprising a first set of computer instructions for controlling the receipt by said computer means via said bus means of said output data from said instrumentation and a second virtual machine comprising a second set of computer instructions for bringing about a computer operation;  
 said computer software controlling display on said screen of a second virtual front panel associated with said second virtual machine;  
 wherein said computer software implements operator controlled selection of ones of said first and second virtual machines to carry out a programmed process involving said instrumentation; and  
 wherein said computer software further implements synthesizing a new virtual machine wherein said new virtual machine is defined by the selected virtual machine and operator selected interrelationship between said selected virtual machines;  
 said computer software further implements user initiated testing of the first virtual machine, wherein said testing of the first virtual machine is operable to be performed before said defining the new virtual machine.

16. The instrumentation system of claim 15, wherein during said testing said computer software is operable to display the output data from said instrumentation in the first virtual front panel.

17. The instrumentation system of claim 15, wherein said user initiated testing operates to test the first virtual machine and said instrumentation.

18. An instrumentation system comprising:  
 computer means;  
 a pointing means for pointing to a location on the screen, wherein the pointing means is coupled to the computer means;  
 instrumentation which operates according to input data for producing output data;  
 bus means connecting the instrumentation to the computer means for carrying said input data from said computer means to said instrumentation and for carrying said output data from said instrumentation to said computer means; and

101

a screen controlled by said computer means;  
 wherein said computer means is controlled by software for  
 displaying on said screen at least a first virtual front  
 panel graphically depicting said instrumentation;  
 wherein said computer software implements a first virtual  
 machine comprising a first set of computer instructions  
 for controlling the receipt by said computer means via  
 said bus means of said output data from said instrumen-  
 tation and a second virtual machine comprising a sec-  
 ond set of computer instructions for bringing about a  
 computer operation;  
 said computer software controlling display on said screen  
 of a second virtual front panel associated with said  
 second virtual machine;  
 wherein said computer software implements operator con-  
 trolled selection of ones of said first and second virtual  
 machines to carry out a programmed process involving  
 said instrumentation; and  
 wherein said computer software further implements syn-  
 thesizing a new virtual machine wherein said new vir-  
 tual machine is defined by the selected virtual machine  
 and operator selected interrelationship between said  
 selected virtual machines;  
 wherein said computer software further implements one or  
 more operations on the first virtual front panel in  
 response to operator input to the pointing means,  
 wherein the one or more operations comprise one or  
 more of resizing the first virtual front panel, moving the  
 first virtual front panel, or closing the first virtual front  
 panel.  
 19. The instrumentation system of claim 18,  
 wherein said operator controlled selection comprises  
 receiving input from the pointing means, wherein said  
 input is indicative of selection of at least one of said first  
 virtual machine or said second virtual machine.  
 20. The instrumentation system of claim 18,  
 wherein the first virtual front panel is displayed in a win-  
 dow, wherein said resizing the first virtual front panel  
 comprises receiving input from the operator resizing the  
 first virtual front panel as displayed on the screen by  
 moving a corner of the window.  
 21. The instrumentation system of claim 18,  
 wherein said moving the first virtual front panel comprises  
 receiving input from the operator relocating the first  
 virtual front panel as displayed on the screen to a new  
 position.  
 22. The instrumentation system of claim 18,  
 wherein said closing the first virtual front panel comprises  
 removing the first virtual front panel from view on the  
 screen.  
 23. An instrumentation system comprising:  
 computer means;  
 pointing means for pointing to a location on the screen,  
 wherein the pointing means is coupled to the computer  
 means;  
 instrumentation which operates according to input data for  
 producing output data;  
 bus means connecting the instrumentation to the computer  
 means for carrying said input data from said computer  
 means to said instrumentation and for carrying said  
 output data from said instrumentation to said computer  
 means; and  
 a screen controlled by said computer means;  
 wherein said computer means is controlled by software for  
 displaying on said screen at least a first virtual front  
 panel graphically depicting said instrumentation;

102

wherein said computer software implements a first virtual  
 machine comprising a first set of computer instructions  
 for controlling the receipt by said computer means via  
 said bus means of said output data from said instrumen-  
 tation and a second virtual machine comprising a sec-  
 ond set of computer instructions for bringing about a  
 computer operation;  
 said computer software controlling display on said screen  
 of a second virtual front panel associated with said  
 second virtual machine;  
 wherein said computer software implements operator con-  
 trolled selection of ones of said first and second virtual  
 machines to carry out a programmed process involving  
 said instrumentation; and  
 wherein said computer software further implements syn-  
 thesizing a new virtual machine wherein said new vir-  
 tual machine is defined by the selected virtual machine  
 and operator selected interrelationship between said  
 selected virtual machines;  
 wherein said computer software further implements  
 inspecting the first virtual machine in response to user  
 input to the pointing means.  
 24. The instrumentation system of claim 23,  
 wherein said inspecting the first virtual machine comprises  
 displaying information about the first virtual machine.  
 25. The instrumentation system of claim 23,  
 wherein the user input to the pointing means to inspect the  
 first virtual machine comprises user input provided to  
 the first virtual front panel.  
 26. An instrumentation system comprising:  
 computer means;  
 pointing means for pointing to a location on the screen,  
 wherein the pointing means is coupled to the computer  
 means;  
 instrumentation which operates according to input data for  
 producing output data;  
 bus means connecting the instrumentation to the computer  
 means for carrying said input data from said computer  
 means to said instrumentation and for carrying said  
 output data from said instrumentation to said computer  
 means; and  
 a screen controlled by said computer means;  
 wherein said computer means is controlled by software for  
 displaying on said screen at least a first virtual front  
 panel graphically depicting said instrumentation;  
 wherein said computer software implements a first virtual  
 machine comprising a first set of computer instructions  
 for controlling the receipt by said computer means via  
 said bus means of said output data from said instrumen-  
 tation and a second virtual machine comprising a sec-  
 ond set of computer instructions for bringing about a  
 computer operation;  
 said computer software controlling display on said screen  
 of a second virtual front panel associated with said  
 second virtual machine;  
 wherein said computer software implements operator con-  
 trolled selection of ones of said first and second virtual  
 machines to carry out a programmed process involving  
 said instrumentation; and  
 wherein said computer software further implements syn-  
 thesizing a new virtual machine wherein said new vir-  
 tual machine is defined by the selected virtual machine  
 and operator selected interrelationship between said  
 selected virtual machines;  
 wherein said computer software further implements creat-  
 ing a new instance of the first virtual machine in  
 response to user input to the pointing means.

27. The instrumentation system of claim 26,  
 wherein said creating a new instance of the first virtual  
 machine comprises creating a new instance of the  
 selected virtual machine in response to the user input to  
 the pointing means.

28. The instrumentation system of claim 26,  
 wherein the user input to the pointing means to inspect the  
 first virtual machine comprises user input provided to  
 the first virtual front panel.

29. An instrumentation system comprising:  
 a computer;  
 an instrument;  
 bus means connecting the instrument to the computer to  
 provide data interchange therebetween;  
 a screen controlled by said computer;  
 means conveying user input including input commands to  
 said computer; and  
 memory means storing software in execution by said com-  
 puter implementing a collection of virtual machines,  
 each virtual machine of said collection of virtual  
 machines comprising a set of instructions, said collec-  
 tion of virtual machines including:  
 a first virtual machine responsive to data on said bus means  
 and displaying on said screen a first virtual front panel  
 representing said instrument; and  
 a plurality of second virtual machines, each producing  
 designated operation output data in response to opera-  
 tion input data, and displaying a separate second virtual  
 front panel on said screen, wherein said first and second  
 virtual machines respond to input commands by gener-  
 ating output computer instructions corresponding to the  
 sets of instructions of said first and second virtual  
 machine;  
 said software further implementing software generation  
 responding to user input selecting ones of said virtual  
 machines by combining the output computer instruc-  
 tions generated by said first and second virtual machines  
 in response to input commands to form new software  
 implementing a third virtual machine performing opera-  
 tions corresponding to the operations of selected first  
 and second virtual machines;  
 wherein the user input selecting ones of said virtual  
 machines comprises receiving input indicative of one or  
 more objects displayed on the screen, wherein the one or  
 more objects are representative of one or more virtual  
 machines.

30. The instrumentation system of claim 29, further com-  
 prising:  
 pointing means for pointing to a location on the screen,  
 wherein the pointing means is coupled to the computer,  
 and wherein the user input selecting ones of said virtual  
 machines comprises receiving input indicative of the one  
 or more displayed objects from the pointing means.

31. The instrumentation system of claim 29,  
 wherein said user input selecting ones of said virtual  
 machines operates to perform one or more operations  
 on the selected virtual machine.

32. The instrumentation system of claim 31,  
 wherein the one or more operations comprise adjusting  
 display of the first virtual front panel.

33. The instrumentation system of claim 31,  
 wherein the one or more operations comprise user initiated  
 testing of the first virtual machine, wherein said testing  
 of the first virtual machine is operable to be performed  
 before said defining the new virtual machine.

34. The instrumentation system of claim 33,  
 wherein during said testing said software is operable to  
 display the output data from the instrument in the first  
 virtual front panel.

35. The instrumentation system of claim 33,  
 wherein said user initiated testing operates to test the first  
 virtual machine and said instrument.

36. An instrumentation system for conducting a procedure  
 with respect to a device under test, comprising:  
 a computer;  
 a plurality of instruments adapted for coupling to said  
 device under test; and  
 bus means connecting said instruments to said computer  
 for providing data communication between said instru-  
 ments and said computer;  
 said computer being controlled by software implementing  
 a plurality of selectable virtual machines, said virtual  
 machines being associated with said plurality of instru-  
 ments, a said virtual machine comprising a set of  
 instructions controlling a corresponding instrument and  
 display on said screen of a corresponding virtual front  
 panel;  
 said software further comprising:  
 software responsive to operator input for enabling  
 selection of ones of said virtual front panels;  
 said computer being responsive to said selection for  
 generating a new virtual machine, said new virtual  
 machine controlling display of a new virtual front  
 panel on said screen;  
 said new virtual machine initiating data transmission  
 with ones of said instruments in response to operator  
 interaction with said new virtual front panel;  
 wherein the corresponding instrument comprises a real  
 front panel, wherein the corresponding virtual front  
 panel corresponds to the real front panel.

37. The instrumentation system of claim 36,  
 wherein the real front panel comprises one or more inputs  
 corresponding to one or more inputs on the correspond-  
 ing virtual front panel.

38. The instrumentation system of claim 36,  
 wherein the real front panel comprises one or more outputs  
 corresponding to one or more outputs on the corre-  
 sponding virtual front panel.

39. The instrumentation system of claim 36  
 wherein selection of ones of said virtual front panels is  
 operable to enable user initiated testing of the virtual  
 machine, wherein said testing of the virtual machine is  
 operable to be performed before said generating the new  
 virtual machine.

40. The instrumentation system of claim 39,  
 wherein during said testing said software is operable to  
 display the output data from the corresponding instru-  
 ment in the corresponding virtual front panel.

41. The instrumentation system of claim 39,  
 wherein said user initiated testing operates to test the vir-  
 tual machine and the corresponding instrument.

42. An instrumentation system comprising:  
 computer means;  
 instrumentation which operates according to input data for  
 producing output data;  
 bus means connecting the instrumentation to the computer  
 means for carrying said input data from said computer  
 means to said instrumentation and for carrying said  
 output data from said instrumentation to said computer  
 means,

wherein the instrumentation comprises one or more computer-based instruments adapted for performing a test; a screen controlled by said computer means; wherein said computer means is controlled by software for displaying on said screen at least a first virtual front panel graphically depicting said instrumentation; wherein said computer software implements a first virtual machine comprising a first set of computer instructions for controlling the receipt by said computer means via said bus means of said output data from said instrumentation and a second virtual machine comprising a second set of computer instructions for bringing about a computer operation; said computer software controlling display on said screen of a second virtual front panel associated with said second virtual machine; wherein said computer software implements operator controlled selection of ones of said first and second virtual machines to carry out a programmed process involving said instrumentation; and wherein said computer software further implements synthesizing a new virtual machine wherein said new virtual machine is defined by the selected virtual machine and operator selected interrelationship between said selected virtual machines; wherein a first of the one or more instruments comprises a first real front panel, wherein the first virtual front panel corresponds to the first real front panel.

43. The instrumentation system of claim 42, wherein the computer-based instruments comprise one or more of voltmeters, signal generators, or other instruments for testing a device under test.

44. The instrumentation system of claim 42, wherein the first real front panel comprises one or more inputs corresponding to one or more inputs on the first virtual front panel.

45. The instrumentation system of claim 42, wherein the first real front panel comprises one or more outputs corresponding to one or more outputs on the first virtual front panel.

46. The instrumentation system of claim 42, wherein operator controlled selection operates to enable user initiated testing of the first virtual machine, wherein said testing of the first virtual machine is operable to be performed before said synthesizing the new virtual machine.

47. The instrumentation system of claim 46, wherein during said testing said computer software is operable to display the output data from the first instrument in the first virtual front panel.

48. The instrumentation system of claim 46, wherein said user initiated testing operates to test the first virtual machine and the first instrument.

49. An instrumentation system for carrying out a procedure with respect to equipment being tested by the instrumentation system, comprising:  
 a computer;  
 bus means coupled to said computer wherein said bus means carries data to and from said computer;  
 instrumentation also coupled to said bus means, at least a portion of said instrumentation receiving data from said computer via said bus means and at least a portion of said instrumentation supplying data to said computer via said bus means;  
 means for coupling at least a portion of said instrumentation to equipment under test; and

a screen controlled by said computer;  
 wherein said computer is controlled by software for displaying on said screen at least one virtual front panel representing at least a said portion of said instrumentation, wherein said software implements a first virtual machine comprising a first set of computer instructions corresponding to a said at least one virtual front panel for controlling coupling of data with a said portion of said instrumentation;  
 wherein said software provides at least one second virtual machine comprising a second set of computer instructions for bringing about performance of a computer operation as well as display on said screen of another virtual front panel representing a said computer operation; and  
 wherein said software is operable in response to operator designation of virtual machines by selection of front panels to generate a combined instruction set from said first and second instruction sets which provides a further front panel, said combined instruction set conjointly controlling said instrumentation for carrying out said procedure; and  
 wherein said software is further operable to respond to operator designation of a value on the first front panel for the first virtual machine, wherein the selected value is generated into the output computer instruction.

50. For an instrumentation system comprising a computer, an instrument, bus means connecting the instrument to the computer, a screen controlled by said computer, and means conveying user input including input commands to said computer, a method for controlling said instrument and displaying values relating thereto, the method comprising the steps of:  
 executing software implementing a first virtual machine comprising a first set of computer instructions corresponding to said instrument and displaying on said screen a first virtual front panel representing said instrument, and implementing a plurality of second virtual machines comprising second sets of computer instructions, each for producing operation output data in response to operation input data and displaying a second virtual front panel on said screen representing an operation controlled by the second virtual machine, wherein said first and second virtual machines respond to input commands for selecting said first and second virtual machines by generating output computer instructions representative of the respective instruction sets of the selected first and second virtual machines;  
 transmitting said input commands to said software pertaining to ones of said first and second virtual machines selected in response to user input;  
 combining output computer instructions generated by said ones of said first and second virtual machines in response to said input commands to form new software implementing a third virtual machine executing a sequence of operations synthesizing the operations of said first and second virtual machines selected in response to user input and displaying on said screen a third virtual front panel representing said third virtual machine, wherein said user input further defines the sources and destinations of input and output data for said first and second virtual machines as synthesized by said third virtual machine; and  
 combining values in response to said input commands for the one or more of the input or output data for one or more of said first and second virtual machines in the new software implementing the third virtual machine; and

executing said new software implementing said third virtual machine.

51. An instrumentation system comprising:

a computer;

a plurality of instruments selectively controlled by input data and producing output data;

bus means connecting said instruments to said computer for conveying input data and output data to and from selected instruments;

a screen controlled by said computer; and

software controlling operation of said computer implementing a plurality of virtual machines each comprising a set of computer instructions, said virtual machines being associated with respective ones of said instruments for providing input thereto or receiving output therefrom, a virtual machine controlling display on said screen of a virtual front panel depicting an instrument and able to display a representation of data associated with an instrument represented by a virtual front panel;

said software further comprising:

software responsive to operator input for enabling a selection of ones of said virtual front panels,

said computer being responsive to said selection for generating a new virtual machine comprising a combined set of the computer instructions which comprises the virtual machines associated with the selection of ones of said virtual front panels, said new virtual machine controlling display of a new virtual front panel on said screen including representation of values conveyed on said bus with respect to instruments represented by said selection of ones of said virtual front panels,

said new virtual machine initiating transmission of input data to one of said instruments in response to changes in values of input data represented by said new virtual front panel and for portraying an output data value as represented by the new virtual front panel in response to output data received from another one of said instruments;

wherein said computer software is responsive to operator input selecting a type of the new virtual front panel associated with the new virtual machine.

52. An instrumentation system for carrying out a procedure with respect to equipment being tested by the instrumentation system, comprising:

a computer;

bus means coupled to said computer wherein said bus means carries data to and from said computer;

instrumentation also coupled to said bus means, at least a portion of said instrumentation receiving data from said computer via said bus means and at least a portion of said instrumentation supplying data to said computer via said bus means;

means for coupling at least a portion of said instrumentation to equipment under test; and

a screen controlled by said computer;

wherein said computer is controlled by software for displaying on said screen at least one virtual front panel representing at least a said portion of said instrumentation, wherein said software implements a first virtual machine comprising a first set of computer instructions corresponding to a said at least one virtual front panel for controlling coupling of data with a said portion of said instrumentation;

wherein said software provides at least one second virtual machine comprising a second set of computer instructions for bringing about performance of a computer

operation as well as display on said screen of another virtual front panel representing a said computer operation; and

wherein said software is operable in response to operator designation of virtual machines by selection of front panels to generate a combined instruction set from said first and second instruction sets which provides a further front panel, said combined instruction set conjointly controlling said instrumentation for carrying out said procedure; and

wherein said operator designation of virtual machines by selection of front panels comprises receiving one or more inputs indicative of one or more objects on the screen, wherein the indicated one or more objects comprise one or more objects corresponding to one or more front panels.

53. An instrumentation system comprising:

a computer;

a plurality of instruments selectively controlled by input data and producing output data;

bus means connecting said instruments to said computer for conveying input data and output data to and from selected instruments;

a screen controlled by said computer; and

software controlling operation of said computer implementing a plurality of virtual machines each comprising a set of computer instructions, said virtual machines being associated with respective ones of said instruments for providing input thereto or receiving output therefrom, a virtual machine controlling display on said screen of a virtual front panel depicting an instrument and able to display a representation of data associated with an instrument represented by a virtual front panel;

said software further comprising:

software responsive to operator input for enabling a selection of ones of said virtual front panels,

said computer being responsive to said selection for generating a new virtual machine comprising a combined set of the computer instructions which comprises the virtual machines associated with the selection of ones of said virtual front panels, said new virtual machine controlling display of a new virtual front panel on said screen including representation of values conveyed on said bus with respect to instruments represented by said selection of ones of said virtual front panels,

said new virtual machine initiating transmission of input data to one of said instruments in response to changes in values of input data represented by said new virtual front panel and for portraying an output data value as represented by the new virtual front panel in response to output data received from another one of said instruments;

said software further controlling user initiated testing of the virtual machine, wherein said testing of the virtual machine is operable to be performed before said generating the new virtual machine.

54. For an instrumentation system comprising a computer, an instrument, bus means connecting the instrument to the computer, a screen controlled by said computer, and means conveying user input including input commands to said computer, a method for controlling said instrument and displaying values relating thereto, the method comprising the steps of:

executing software implementing a first virtual machine comprising a first set of computer instructions corresponding to said instrument and displaying on said screen a first virtual front panel representing said instru-

109

ment, and implementing a plurality of second virtual machines comprising second sets of computer instructions, each for producing operation output data in response to operation input data and displaying a second virtual front panel on said screen representing an operation controlled by the second virtual machine, wherein said first and second virtual machines respond to input commands for selecting said first and second virtual machines by generating output computer instructions representative of the respective instruction sets of the selected first and second virtual machines; wherein said input commands for selecting said first and second virtual machines are indicative of objects displayed on the screen, wherein said displayed objects comprise one or more objects corresponding to said first virtual machine and one or more of said plurality of second virtual machines; wherein said user input selecting ones of said virtual machines operates to perform one or more operations on the selected virtual machine; transmitting said input commands to said software pertaining to ones of said first and second virtual machines selected in response to user input;

110

combining output computer instructions generated by said ones of said first and second virtual machines in response to said input commands to form new software implementing a third virtual machine executing a sequence of operations synthesizing the operations of said first and second virtual machines selected in response to user input and displaying on said screen a third virtual front panel representing said third virtual machine, wherein said user input further defines the sources and destinations of input and output data for said first and second virtual machines as synthesized by said third virtual machine; and executing said new software implementing said third virtual machine.

55. The instrumentation system of claim 54, wherein the one or more operations comprise adjusting display of the first virtual front panel.

56. The instrumentation system of claim 54, wherein the one or more operations comprise user initiated testing of the first virtual machine, wherein said testing of the first virtual machine is operable to be performed before said implementing the third virtual machine.

\* \* \* \* \*