

(19) World Intellectual Property  
Organization  
International Bureau



(43) International Publication Date  
24 February 2005 (24.02.2005)

PCT

(10) International Publication Number  
**WO 2005/016095 A1**

- (51) International Patent Classification<sup>7</sup>: **A47J 31/46**, 31/06
- (21) International Application Number:  
PCT/IB2004/051402
- (22) International Filing Date: 5 August 2004 (05.08.2004)
- (25) Filing Language: English
- (26) Publication Language: English
- (30) Priority Data:  
03102590.1 19 August 2003 (19.08.2003) EP
- (71) Applicant (for all designated States except US): **KONINKLIJKE PHILIPS ELECTRONICS N.V.** [NL/NL]; Groenewoudseweg 1, NL-5621 BA Eindhoven (NL).
- (72) Inventor; and
- (75) Inventor/Applicant (for US only): **NOORDHUIS, Joeke** [NL/NL]; c/o Prof. Holstlaan 6, NL-5656 AA Eindhoven (NL).
- (74) Agent: **SCHOUTEN, Marcus, M.**; Prof. Holstlaan 6, NL-5656 AA Eindhoven (NL).
- (81) Designated States (unless otherwise indicated, for every kind of national protection available): AE, AG, AL, AM, AT, AU, AZ, BA, BB, BG, BR, BW, BY, BZ, CA, CH, CN, CO, CR, CU, CZ, DE, DK, DM, DZ, EC, EE, EG, ES, FI, GB, GD, GE, GH, GM, HR, HU, ID, IL, IN, IS, JP, KE, KG, KP, KR, KZ, LC, LK, LR, LS, LT, LU, LV, MA, MD, MG, MK, MN, MW, MX, MZ, NA, NI, NO, NZ, OM, PG, PH, PL, PT, RO, RU, SC, SD, SE, SG, SK, SL, SY, TJ, TM, TN, TR, TT, TZ, UA, UG, US, UZ, VC, VN, YU, ZA, ZM, ZW.
- (84) Designated States (unless otherwise indicated, for every kind of regional protection available): ARIPO (BW, GH, GM, KE, LS, MW, MZ, NA, SD, SL, SZ, TZ, UG, ZM, ZW), Eurasian (AM, AZ, BY, KG, KZ, MD, RU, TJ, TM), European (AT, BE, BG, CH, CY, CZ, DE, DK, EE, ES, FI, FR, GB, GR, HU, IE, IT, LU, MC, NL, PL, PT, RO, SE, SI, SK, TR), OAPI (BF, BJ, CF, CG, CI, CM, GA, GN, GQ, GW, ML, MR, NE, SN, TD, TG).

**Declaration under Rule 4.17:**

— as to applicant's entitlement to apply for and be granted a patent (Rule 4.17(ii)) for the following designations AE, AG, AL, AM, AT, AU, AZ, BA, BB, BG, BR, BW, BY, BZ,

[Continued on next page]

(54) Title: A BEVERAGE MAKING DEVICE COMPRISING A FROTHING MEMBER

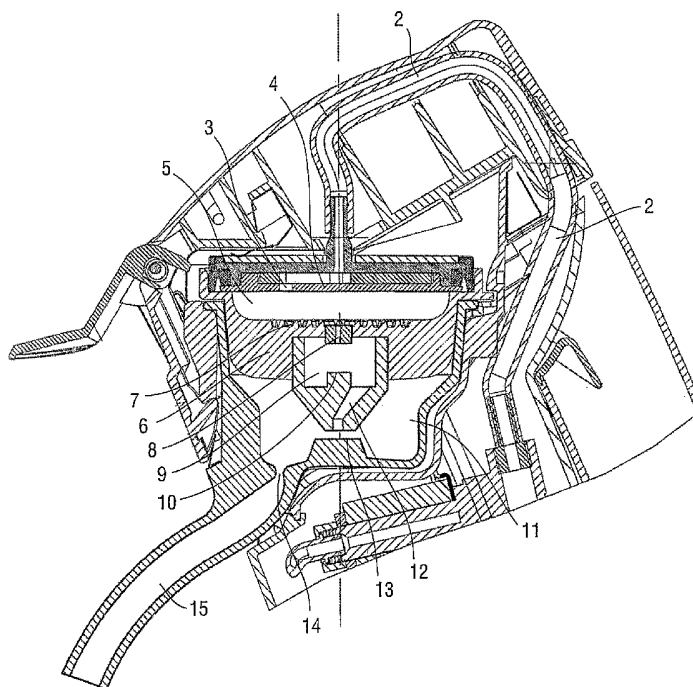

(57) Abstract: A beverage making device comprising a frothing member (9) for producing froth in the beverage, which device comprises a settling chamber (11) for settling the frothed beverage coming from the frothing member (9). The coarse foam is separated from the fine foam thereby. The outlet (14) for the settled beverage is at the lower side of the settling chamber (11).

WO 2005/016095 A1



CA, CH, CN, CO, CR, CU, CZ, DE, DK, DM, DZ, EC, EE, EG, ES, FI, GB, GD, GE, GH, GM, HR, HU, ID, IL, IN, IS, JP, KE, KG, KP, KR, KZ, LC, LK, LR, LS, LT, LU, LV, MA, MD, MG, MK, MN, MW, MX, MZ, NA, NI, NO, NZ, OM, PG, PH, PL, PT, RO, RU, SC, SD, SE, SG, SK, SL, SY, TJ, TM, TN, TR, TT, TZ, UA, UG, UZ, VC, VN, YU, ZA, ZM, ZW, ARIPO patent (BW, GH, GM, KE, LS, MW, MZ, NA, SD, SL, SZ, TZ, UG, ZM, ZW), Eurasian patent (AM, AZ, BY, KG, KZ, MD, RU, TJ, TM), European patent (AT, BE, BG, CH, CY, CZ, DE, DK, EE, ES, FI, FR, GB, GR, HU, IE,

IT, LU, MC, NL, PL, PT, RO, SE, SI, SK, TR), OAPI patent (BF, BJ, CF, CG, CI, CM, GA, GN, GQ, GW, ML, MR, NE, SN, TD, TG)

**Published:**

— with international search report

For two-letter codes and other abbreviations, refer to the "Guidance Notes on Codes and Abbreviations" appearing at the beginning of each regular issue of the PCT Gazette.

A beverage making device comprising a frothing member

The invention relates to a beverage making device comprising a frothing member for producing froth in the beverage. A beverage can be made by means of the device in an extraction process, for example to produce coffee, or in a dissolving process, for example to produce a chocolate drink.

5

Such a device is disclosed in EP-A-1092377, which publication describes a device for making coffee comprising a brewing chamber in which a pad containing ground coffee can be placed. The coffee is extracted by hot water supplied through holes in the upper wall of the brewing chamber. The hot water passes through the pad, and the brewed beverage (coffee extract) is collected at the central portion of the bottom of the brewing chamber and is injected into a frothing chamber through a nozzle in the bottom of the brewing chamber. The coffee extract is thus injected into the coffee extract that had previously entered the frothing chamber, so that air is mixed with the coffee extract and froth (foam) is created. Subsequently the frothed coffee extract is guided by outflow means to outside the device, where one or two cups to be filled with the frothed coffee extract are present. The coffee in the cups will have a froth layer on top.

As described in EP-A-1092377, the stability of the froth can be enhanced by the creation fine-bubble froth (i.e. fine foam) without large air bubbles (i.e. a mono-dispersed distribution of small bubble sizes). The larger air bubbles grow via Ostwald ripening and break up soon, causing the entire froth layer to become unstable by broadening the size distribution further, and they dissolve rapidly by creating shock waves. However, it is difficult to avoid the creation of larger air bubbles (i.e. coarse foam) in the froth. Even when the amount of larger air bubbles is minimized, a small quantity of large air bubbles in the froth layer on the coffee may result in a rapid disappearance of the entire froth layer.

The object of the invention is to provide a stable froth layer on the beverage produced by the beverage making device by avoiding larger air bubbles in the froth layer.

To accomplish that object, the device comprises a settling chamber for settling the frothed beverage coming from the frothing member, the outlet for the settled beverage being at the lower side of said settling chamber. If the frothed beverage is buffered for some time in the settling chamber, the larger air bubbles will move in upward direction with respect to the smaller air bubbles, so that the coarse foam comes to rest above the fine foam. Since the outlet of the settling chamber is located at the lower side, i.e. at the bottom of the settling chamber, the coarse foam will stay behind in the settling chamber until all coffee extract, including the fine foam, has left the settling chamber. By that time the largest air bubbles will have become dissolved.

In one preferred embodiment, the device comprises a brewing chamber for brewing the beverage, means for feeding hot water into said brewing chamber, and nozzle means for supplying the brewed beverage to the frothing member, as described above. The nozzle means can thus inject the beverage into the frothing member, so that froth is created by the turbulence, i.e. air is mixed with the beverage.

It is important that the beverage in the settling chamber should come to a relative rest. Such a condition of rest may be achieved by waiting some time, but preferably the rest is the result of the way in which the frothed beverage is introduced into the settling chamber. The inlet for supplying the frothed beverage into the settling chamber is then preferably located near the expected upper surface of the beverage in the settling chamber, so that the inflow of the beverage does not cause heavy turbulence.

In one preferred embodiment, the frothed beverage is guided along a guiding surface in the settling chamber. Such a guiding surface avoids much turbulence when the incoming beverage comes into contact with the beverage that is already present in the settling chamber. The guiding surface may be located in the central portion of the settling chamber and is preferably a substantially horizontal surface, which surface is preferably located just above the expected upper surface of the beverage in the settling chamber. The frothed beverage can thus enter the settling chamber through a central inlet in the upper wall of the settling chamber, which is an advantageous location if the settling chamber is located underneath the frothing member.

In another preferred embodiment the guiding surface is a portion of the surface of the side wall of the settling chamber. In this case the inlet for feeding the frothed beverage into the settling chamber may direct its outflow against the side wall of the settling chamber, so that the beverage flows along the surface of the side wall to the beverage that is already present in the settling chamber.

Preferably, the outlet of the settling chamber has an opening of less than 4 mm<sup>2</sup>, preferably an opening of less than 2 mm<sup>2</sup>. The restriction in the outlet of the settling chamber has two functions. Firstly it increases the time that the beverage remains in the settling chamber, and secondly it avoids that the largest air bubbles can pass the outlet. The outlet preferably has a substantially round opening.

Outflow means may extend outside the device in order to guide the beverage to one or two cups. The outflow means then guide the beverage from the frothing member over a certain distance to the outflow opening outside the device, and the settling chamber may form an integral part of said outflow means.

In one preferred embodiment, part of the device can be removed from the remainder of the device, said part comprising the frothing member, the settling chamber, and the outflow means for guiding the beverage to outside the device.

The invention also relates to a method of making a beverage by means of a beverage making device comprising a frothing member for producing froth in the beverage, wherein the frothed beverage is guided into a settling chamber for settling the frothed beverage, and wherein the settled beverage is guided from the settling chamber through an outlet at the lower side of the settling chamber.

The invention will now be further explained by means of a description of an embodiment of a device for making coffee, in which reference is made to the drawing comprising a Figure that shows a sectional view of a portion of the device.

The Figure shows the relevant part (i.e. the uppermost portion) of a device for making coffee. The other part of the device, which is not shown, comprises a water container and means for heating the water and pumping a predetermined quantity of the heated water through a tube 2 to a number of holes 3 in the upper wall 4 of a brewing chamber 5. The sectional view of the Figure only shows one hole 3 in the upper wall 4, but there are more holes, spread out over the surface of the upper wall 4.

Brewing chamber 5 has a substantially cylindrical shape that fits a disc-like pad (not shown) containing, for example, ground coffee. The coffee is extracted by a supply of hot water under pressure through the holes 3, so that the water passes said disc-like pad.

The lower wall 6 of the brewing chamber 5 is provided with a profile 7 so as to form canals for allowing the brewed coffee to arrive at the central portion of the bottom of the brewing chamber 5, where outflow means in the form of nozzle 8 are located. Nozzle 8 is

attached to the lower wall 6 by a screw thread. The coffee extract passes through the nozzle 8, which causes a liquid jet in downward direction into a frothing chamber 9, because of the relatively high liquid pressure in the brewing chamber 5.

5 Frothing chamber 9 is provided with a central horizontal plateau 10. The liquid jet coming from the nozzle 8 strikes against the plateau 10, so that the coffee extract is splashed against the side wall of the frothing chamber 9. The coffee extract is mixed with air thereby, and the resulting turbulence creates air bubbles in the coffee extract. Subsequently the coffee extract, including the air bubbles, flows into a settling chamber 11, where the coffee extract comes to rest, so that the larger air bubbles will rise above the smaller air  
10 bubbles.

The coffee extract is supplied from the frothing chamber 9 to the settling chamber 11 through an inlet 12. The outflow opening of inlet 12 is located near a horizontal guiding surface 13 in the central portion of the settling chamber 11. The level of the guiding surface 13 is a little higher than the expected highest level of the coffee extract in the settling  
15 chamber 11, so that the guiding surface 13 will guide the coffee extract from said opening of inlet 12 to the coffee extract that is already in the settling chamber, without causing turbulence in the coffee extract.

Instead of against the horizontal guiding surface 13, the inlet of the settling chamber may direct incoming frothed coffee extract against a side wall or another wall of the  
20 settling chamber. It was found in all cases that turbulence in the settling chamber can be avoided by making use of a guiding surface for guiding the coffee extract into the liquid in the settling chamber.

It was found that the foam in the coffee extract will separate into fine foam in the lower part of the settling chamber 11 and coarse foam on top of the fine foam within a  
25 short time. The outlet 14 of the settling chamber 11 is located at the lower side of that chamber, so that the coffee extract with the fine foam (i.e. the small air bubbles) will flow through it, whereas the coarse foam (i.e. the larger air bubbles) will remain in the settling chamber. It was found in practice that the coarse foam will not pass the outlet 14, because the major portion thereof has disappeared before the settling chamber 11 is empty, and the  
30 remainder of the coarse foam disappears when it tries to pass the outlet opening 14.

The diameter of the outlet opening 14 is limited so as to form a restriction, so that the coffee extract is buffered for a short time in the settling chamber 11. After passing the outlet opening 14, the coffee extract with the fine foam flows through outflow means 15

to outside the device, where it can be caught by a cup (not shown). A foam layer of relatively fine air bubbles will be on top of the coffee extract in the cup.

The embodiment as described above is only an example; a great many other embodiments are possible.

## CLAIMS:

1. A beverage making device comprising a frothing member (9) for producing froth in the beverage, characterized in that the device comprises a settling chamber (11) for allowing the frothed beverage coming from the frothing member (9) to settle, and in that the outlet (14) for the settled beverage is at the lower side of the settling chamber (11).
- 5
2. A beverage making device as claimed in claim 1, characterized in that the device comprises a brewing chamber (5) for brewing the beverage, means for feeding hot water into said brewing chamber (5), and outflow means for supplying the brewed beverage to the frothing member (9).
- 10
3. A beverage making device as claimed in any one of the preceding claims, characterized in that the beverage is injected into the frothing member (9).
4. A beverage making device as claimed in any one of the preceding claims, characterized in that an inlet (12) for supplying the frothed beverage to the settling chamber (11) is located near the expected upper surface of the beverage in the settling chamber (11).
- 15
5. A beverage making device as claimed in any one of the preceding claims, characterized in that the frothed beverage is guided along a guiding surface (13) in the settling chamber (11).
- 20
6. A beverage making device as claimed in claim 5, characterized in that the guiding surface (13) is located in the central portion of the settling chamber (11) and is preferably a substantial horizontally surface.
- 25
7. A beverage making device as claimed in claim 5, characterized in that the guiding surface is a portion of the surface of the side wall of the settling chamber (11).



8. A beverage making device as claimed in any one of the preceding claims, characterized in that said outlet (14) has an opening of less than 4 mm<sup>2</sup>, preferably an opening of less than 2 mm<sup>2</sup>.
- 5 9. A beverage making device as claimed in any one of the preceding claims, characterized in that said outlet (14) has a substantially circular opening.
10. A beverage making device as claimed in any one of the preceding claims, characterized in that part of the device can be removed from the remainder of the device, said  
10 part comprising the frothing member (9), the settling chamber (11), and outflow means (15) for guiding the beverage to outside the device.
11. A method of making a beverage by means of a beverage making device comprising a frothing member (9) for producing froth in the beverage, characterized in that  
15 the frothed beverage is guided into a settling chamber (11) for settling the frothed beverage, and in that the settled beverage is guided out of the settling chamber (11) through an outlet (14) at the lower side of the settling chamber (11).

1/1

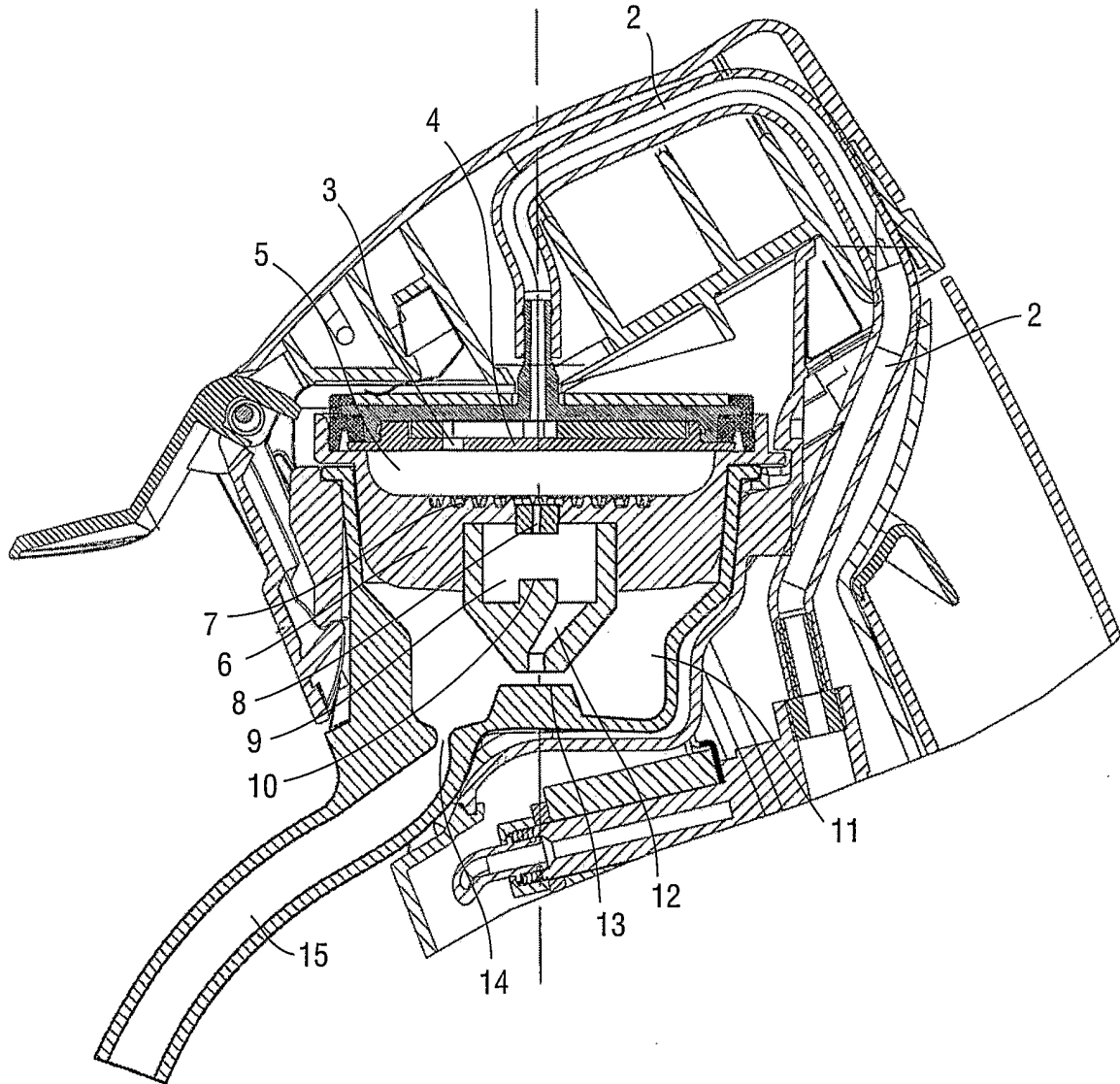

FIG. 1

## INTERNATIONAL SEARCH REPORT

International Application No

/IB2004/051402

A. CLASSIFICATION OF SUBJECT MATTER  
 IPC 7 A47J31/46 A47J31/06

According to International Patent Classification (IPC) or to both national classification and IPC

## B. FIELDS SEARCHED

Minimum documentation searched (classification system followed by classification symbols)  
 IPC 7 A47J

Documentation searched other than minimum documentation to the extent that such documents are included in the fields searched

Electronic data base consulted during the international search (name of data base and, where practical, search terms used)

EPO-Internal

## C. DOCUMENTS CONSIDERED TO BE RELEVANT

Category °	Citation of document, with indication, where appropriate, of the relevant passages	Relevant to claim No.
X	WO 02/091889 A (LONGHI SPA DE ; DE LONGHI GIUSEPPE (IT)) 21 November 2002 (2002-11-21) page 4, paragraph 3 - page 11; figures	1-11
X	WO 03/055366 A (KODDEN HANS ; NOORDHUIS JOEKE (NL); KONINKL PHILIPS ELECTRONICS NV (NL) 10 July 2003 (2003-07-10) page 2, line 30 - page 7; figures	1-11
X	EP 1 125 535 A (PETRONCINI IMPIANTI S R L) 22 August 2001 (2001-08-22) paragraphs '0025! - '0053!; figures	1-11

Further documents are listed in the continuation of box C.

Patent family members are listed in annex.

° Special categories of cited documents :

- \*A\* document defining the general state of the art which is not considered to be of particular relevance
- \*E\* earlier document but published on or after the international filing date
- \*L\* document which may throw doubts on priority claim(s) or which is cited to establish the publication date of another citation or other special reason (as specified)
- \*O\* document referring to an oral disclosure, use, exhibition or other means
- \*P\* document published prior to the international filing date but later than the priority date claimed

- \*T\* later document published after the international filing date or priority date and not in conflict with the application but cited to understand the principle or theory underlying the invention
- \*X\* document of particular relevance; the claimed invention cannot be considered novel or cannot be considered to involve an inventive step when the document is taken alone
- \*Y\* document of particular relevance; the claimed invention cannot be considered to involve an inventive step when the document is combined with one or more other such documents, such combination being obvious to a person skilled in the art.
- \* & \* document member of the same patent family

Date of the actual completion of the international search

2 November 2004

Date of mailing of the international search report

09/11/2004

Name and mailing address of the ISA

European Patent Office, P.B. 5818 Patentlaan 2  
 NL - 2280 HV Rijswijk  
 Tel. (+31-70) 340-2040, Tx. 31 651 epo nl,  
 Fax: (+31-70) 340-3016

Authorized officer

Van Bastelaere, T

## INTERNATIONAL SEARCH REPORT

Information on patent family members

International Application No

/IB2004/051402

Patent document cited in search report		Publication date		Patent family member(s)	Publication date
WO 02091889	A	21-11-2002	IT	MI20010972 A1	11-11-2002
			WO	02091889 A2	21-11-2002
			EP	1389934 A2	25-02-2004
			US	2004112223 A1	17-06-2004
-----					
WO 03055366	A	10-07-2003	EP	1460921 A2	29-09-2004
			WO	03055366 A2	10-07-2003
-----					
EP 1125535	A	22-08-2001	IT	B020000051 A1	07-08-2001
			AT	249776 T	15-10-2003
			AU	7201600 A	09-08-2001
			CA	2327073 A1	07-08-2001
			DE	60005292 D1	23-10-2003
			DE	60005292 T2	01-04-2004
			EP	1125535 A2	22-08-2001
			ES	2204450 T3	01-05-2004
			PT	1125535 T	27-02-2004
			SI	1125535 T1	29-02-2004
			US	2001050002 A1	13-12-2001
-----					