

F. F. RAYMOND, 2d.

NAIL MAKING MACHINE.

No. 344,985.

Patented July 6, 1886.

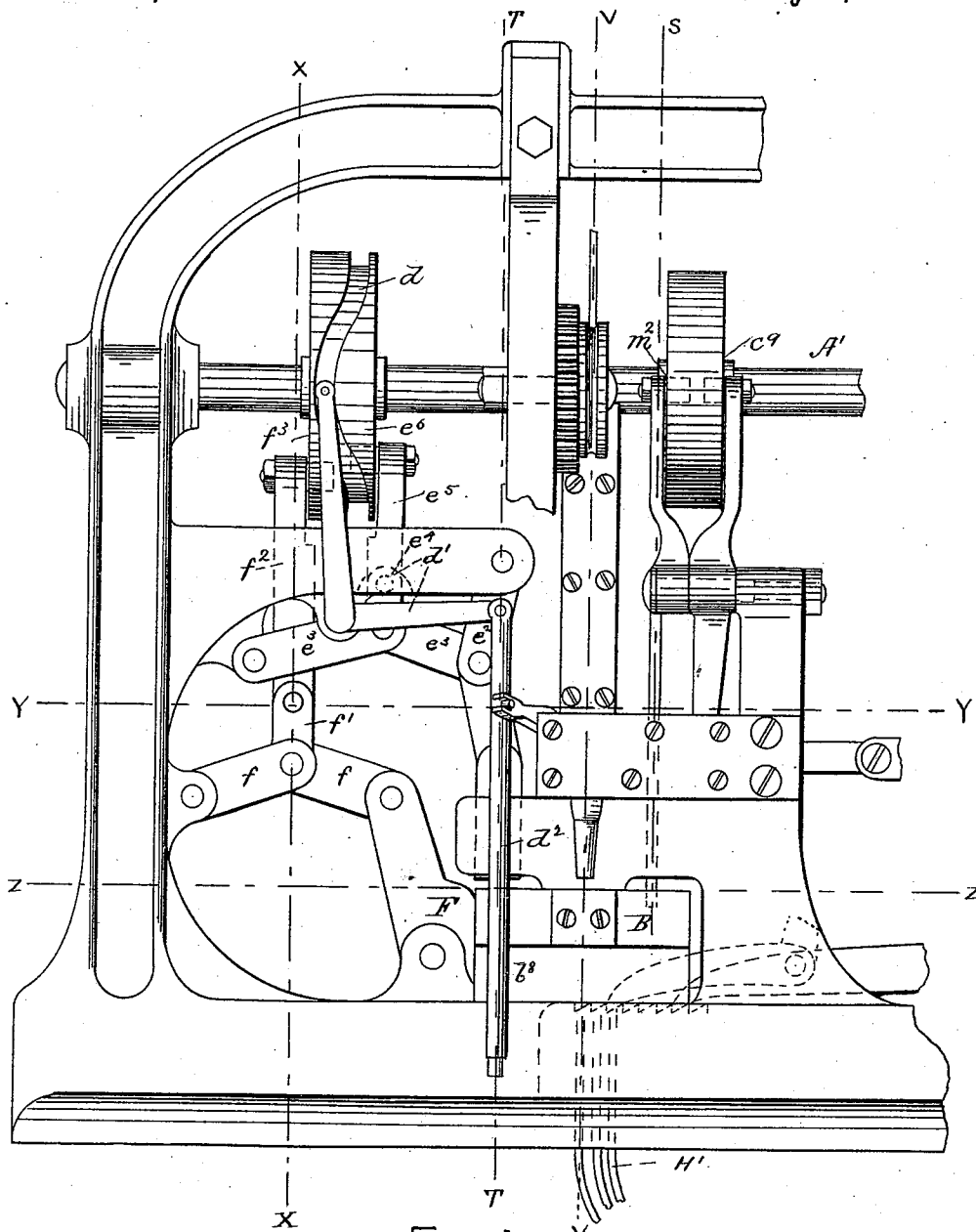

Fig. 1

WITNESSES.

*J. M. Dolan*  
*Fred. B. Dolan*

INVENTOR

*F. F. Raymond*

(No Model.)

11 Sheets—Sheet 2.

F. F. RAYMOND, 2d.

NAIL MAKING MACHINE.

No. 344,985.

Patented July 6, 1886.

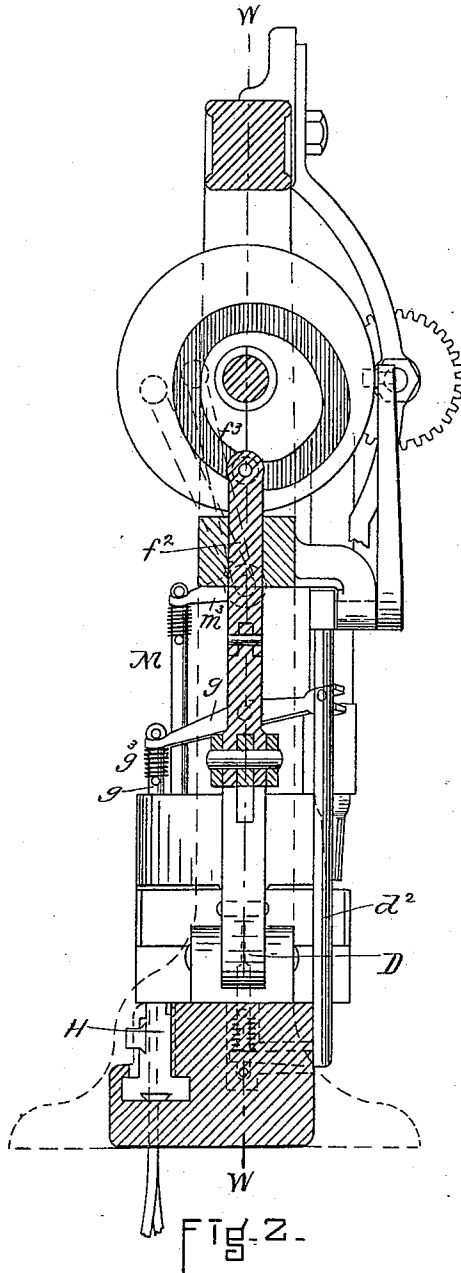

WITNESSES

J. M. Dolan.

Fred. B. Dolan.

INVENTOR

F. F. Raymond.

(No Model.)

11 Sheets—Sheet 3.

F. F. RAYMOND, 2d.

NAIL MAKING MACHINE.

No. 344,985.

Patented July 6, 1886.

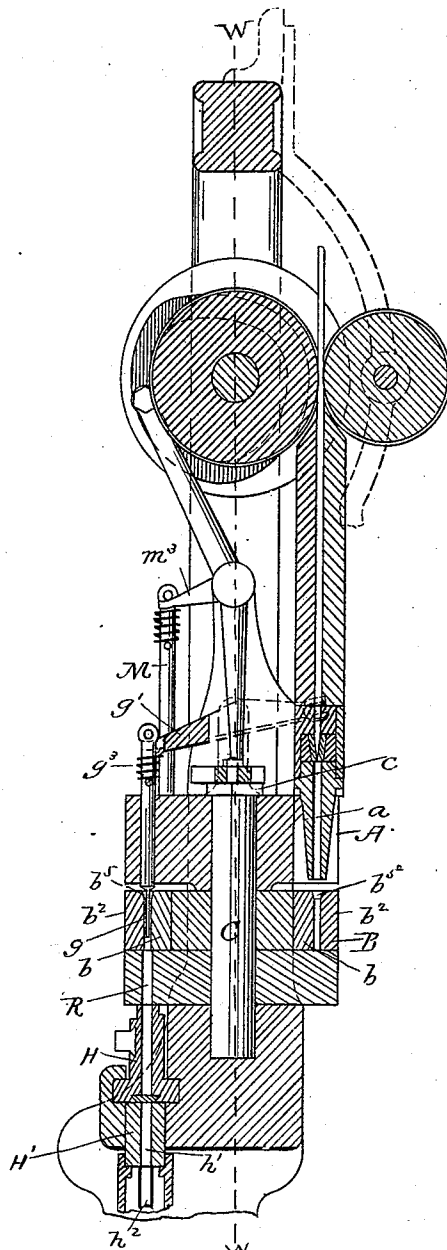

Fig. 3.

WITNESSES

J. M. Dolan  
Fred. B. Dolan

INVENTOR

F. F. Raymond

F. F. RAYMOND, 2d.

NAIL MAKING MACHINE.

No. 344,985.

Patented July 6, 1886.

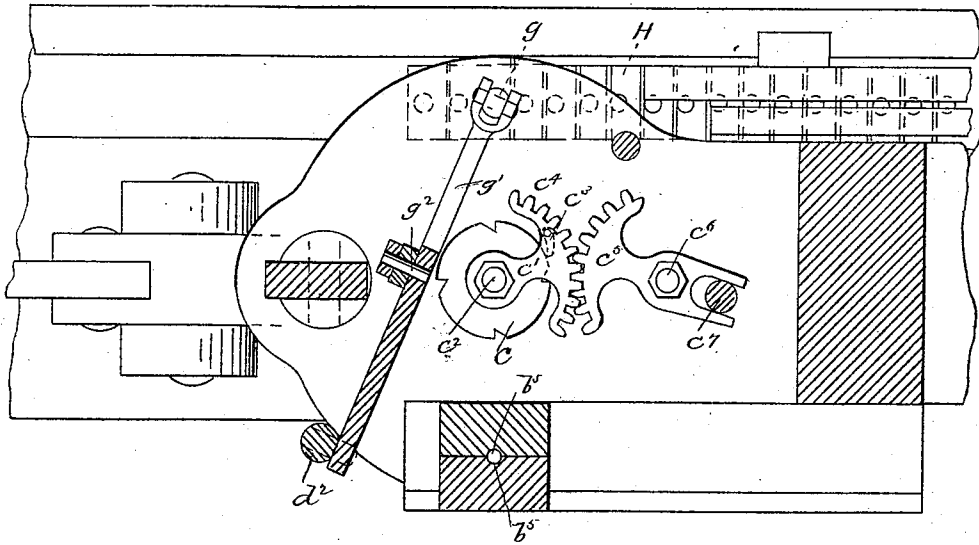

Fig. 4.

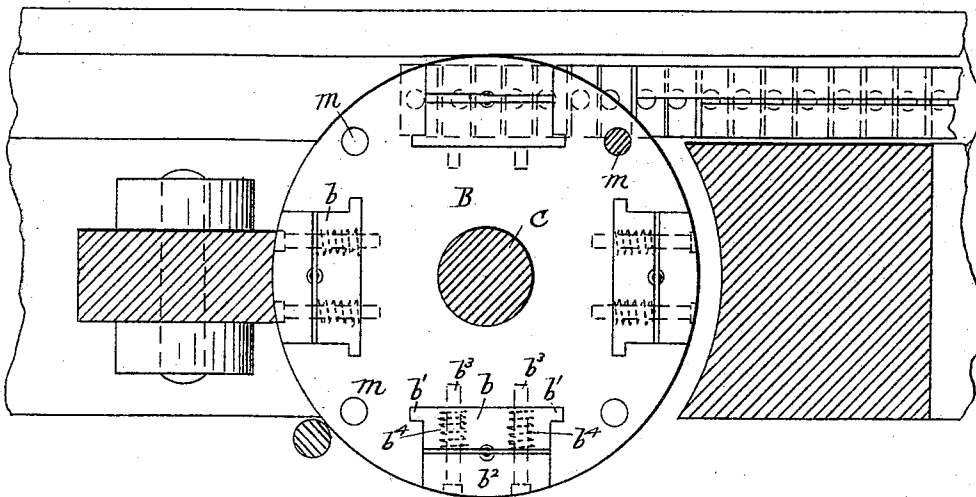

Fig. 5.

WITNESSES

*J. M. Dolan*

*E. B. Dolan*

INVENTOR  
*F. F. Raymond*

F. F. RAYMOND, 2d.

• NAIL MAKING MACHINE.

No. 344,985.

Patented July 6, 1886.

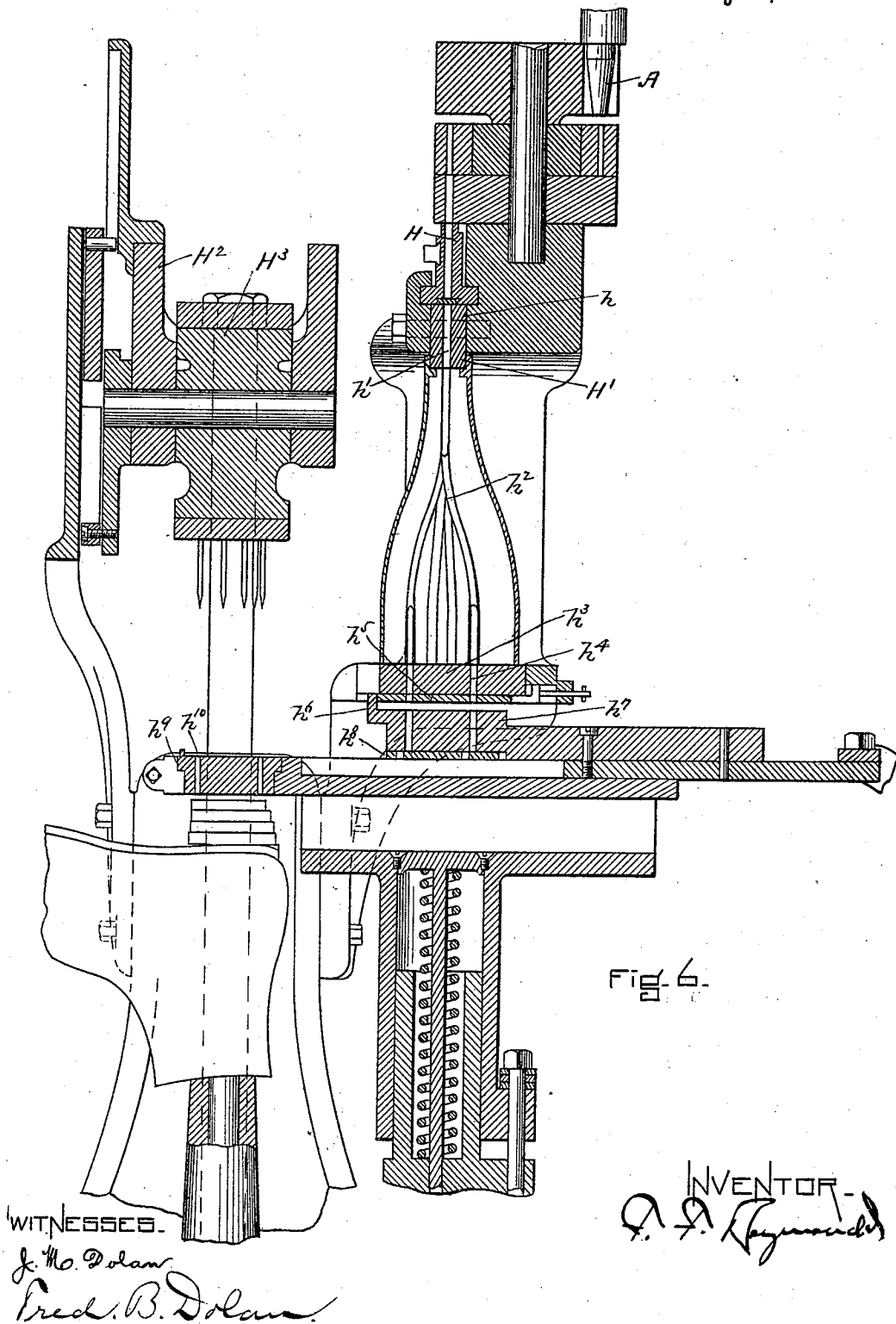

(No Model.)

11 Sheets—Sheet 6.

F. F. RAYMOND, 2d.  
NAIL MAKING MACHINE.

No. 344,985.

Patented July 6, 1886.

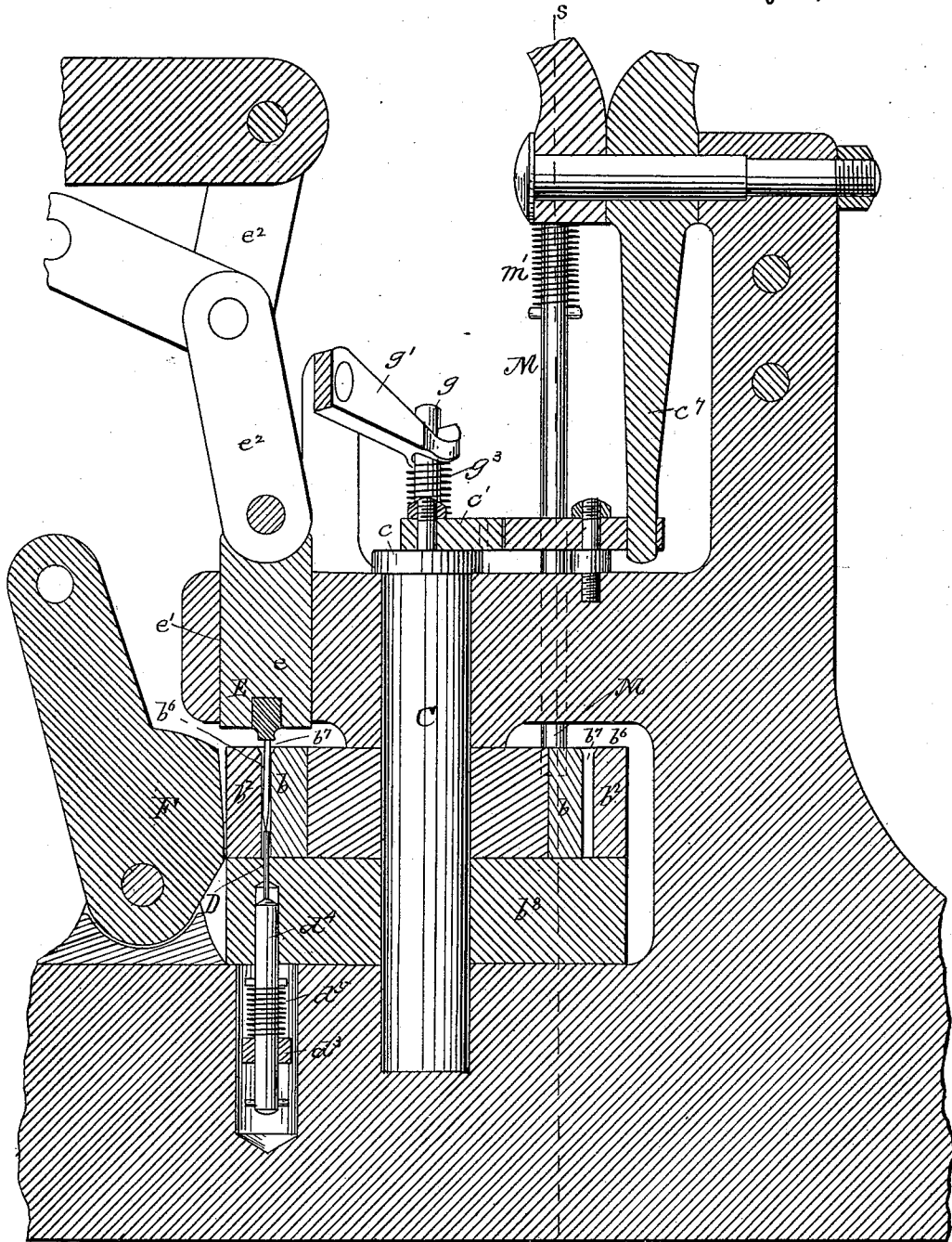

Fig 7 - s

WITNESSES

*J. Mc. Dolan*  
*Fred. B. Dolan*

INVENTOR

*F. F. Raymond*

(No Model.)

11 Sheets—Sheet 7.

F. F. RAYMOND, 2d.

NAIL MAKING MACHINE.

No. 344,985.

Patented July 6, 1886.

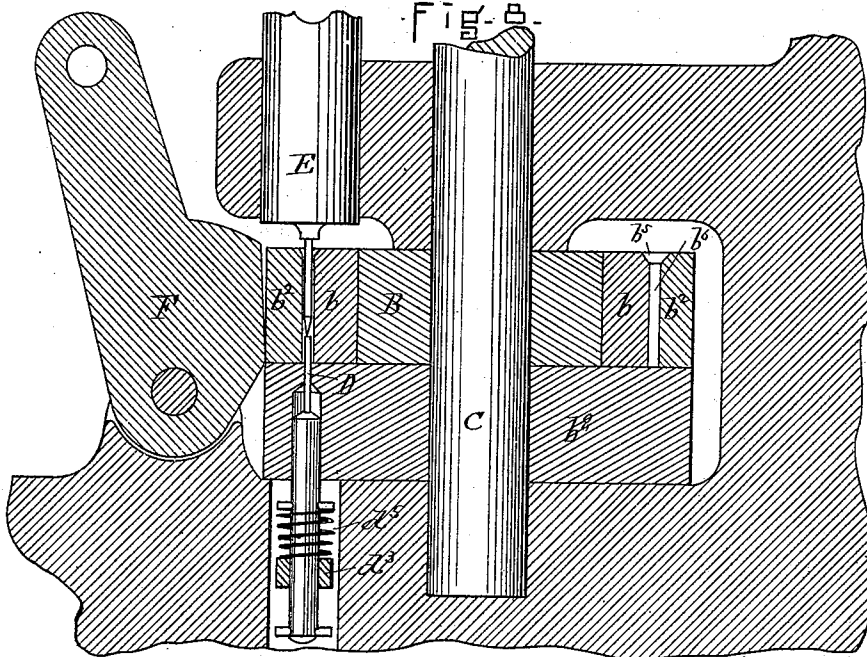
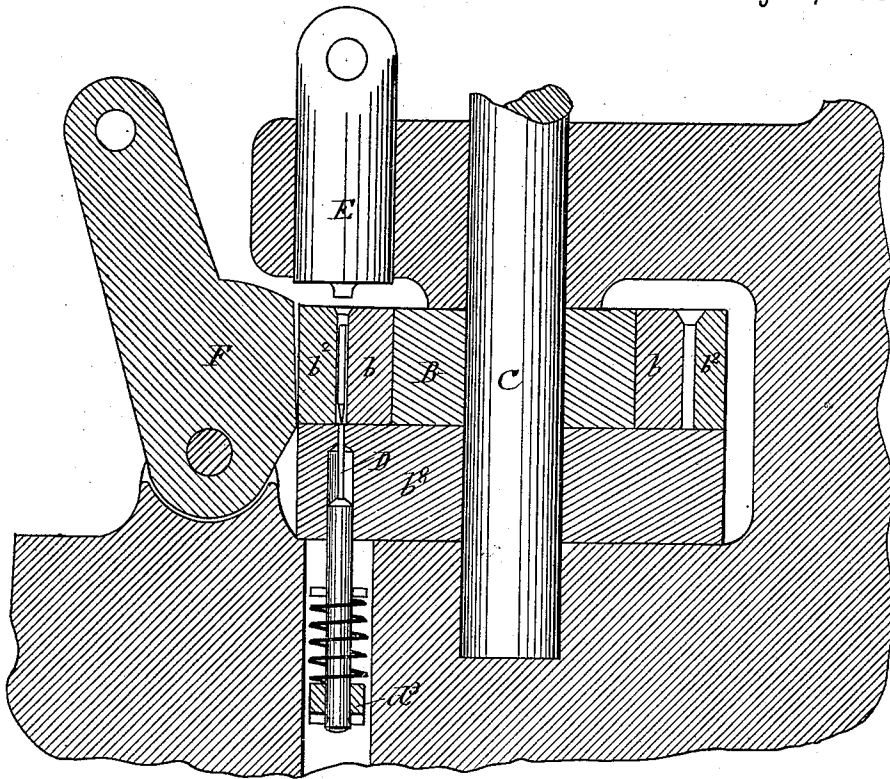

WITNESSES

J. W. Dolan.

Fred. B. Dolan.

Fig. 9.

INVENTOR  
F. F. Raymond

F. F. RAYMOND, 2d.  
NAIL MAKING MACHINE.

No. 344,985.

Patented July 6, 1886.

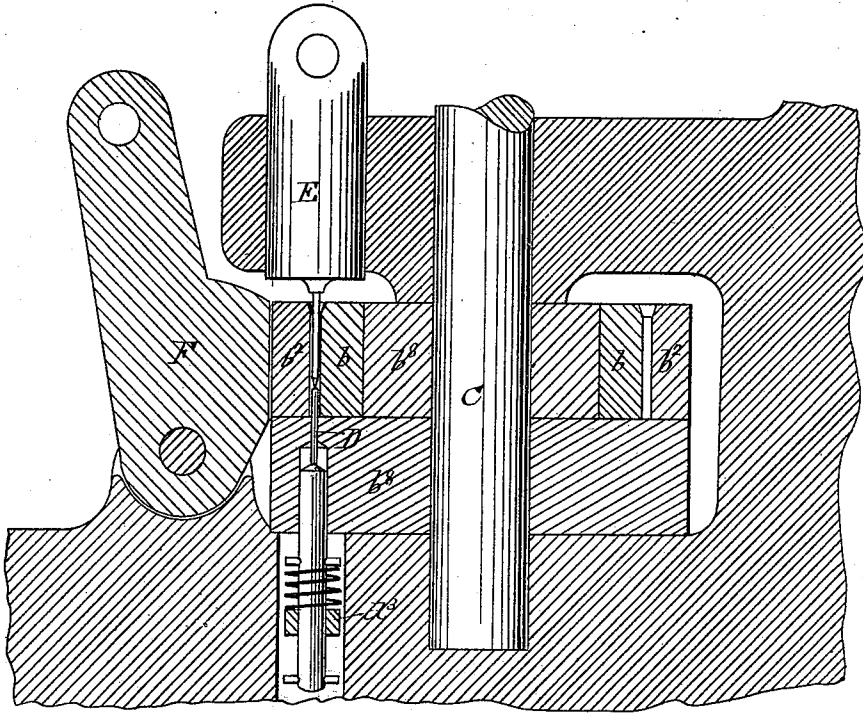

FIG. 10.

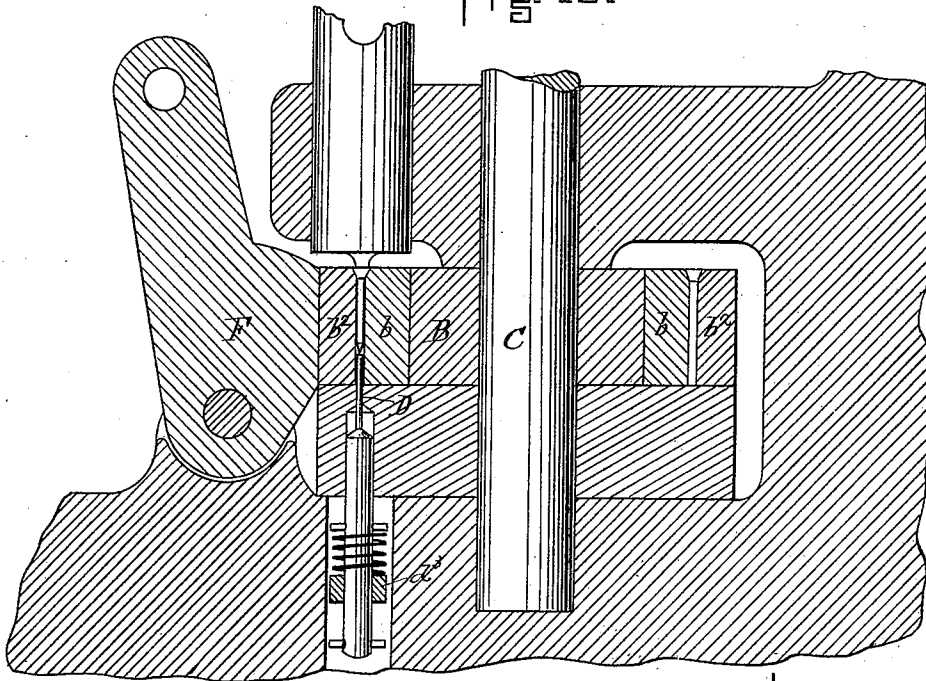

FIG. 11.

WITNESSES

*J. W. Dolan*  
*Fred. B. Dolan*

INVENTOR  
*F. F. Raymond*

F. F. RAYMOND, 2d.

NAIL MAKING MACHINE.

No. 344,985.

Patented July 6, 1886.

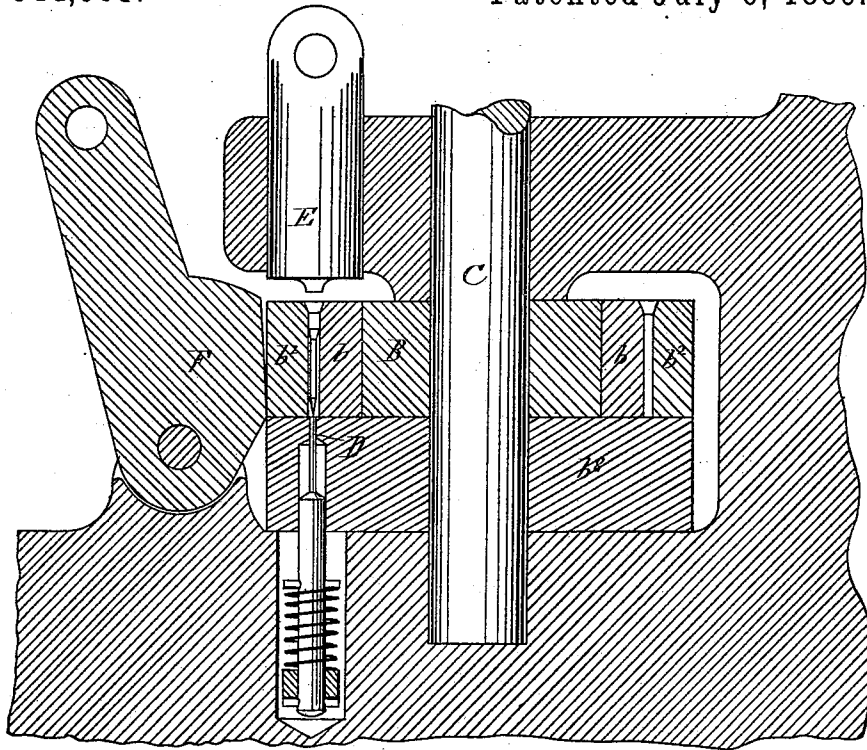

Fig. 12.

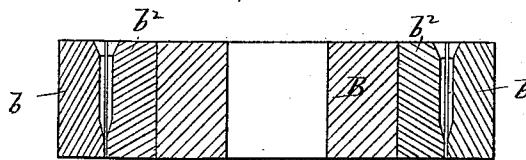

Fig. 18.

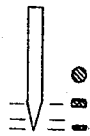

Fig. 19.

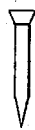

Fig. 20.

WITNESSES

*J. W. Dolan*  
*Fred. B. Dolan*

INVENTOR

*F. F. Raymond*

F. F. RAYMOND, 2d.

NAIL MAKING MACHINE.

No. 344,985.

Patented July 6, 1886.

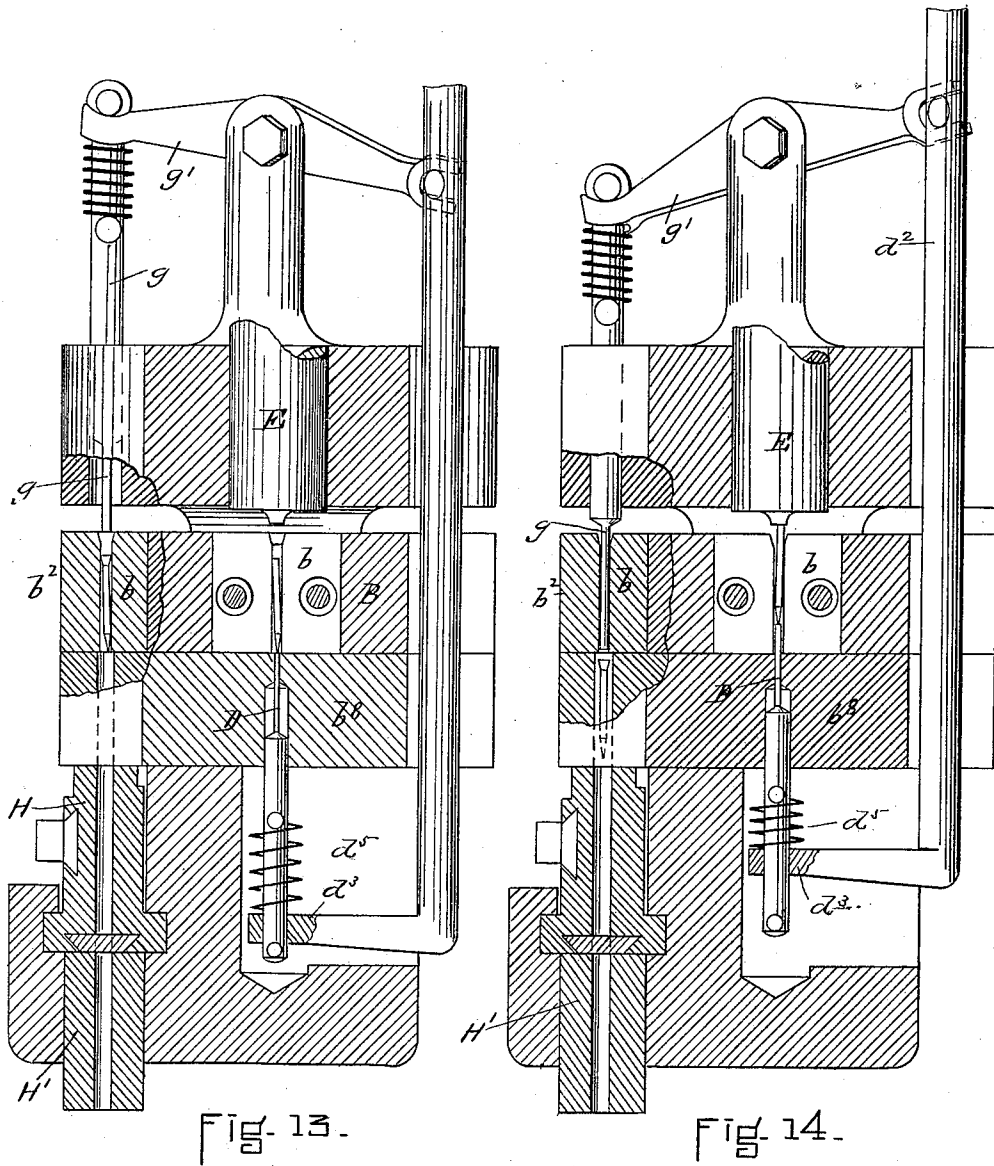

WITNESSES

J. M. Dolan  
Fred. B. Dolan

INVENTOR  
F. F. Raymond, 2d.

(No Model.)

11 Sheets—Sheet 11.

F. F. RAYMOND, 2d.

NAIL MAKING MACHINE.

No. 344,985.

Patented July 6, 1886.

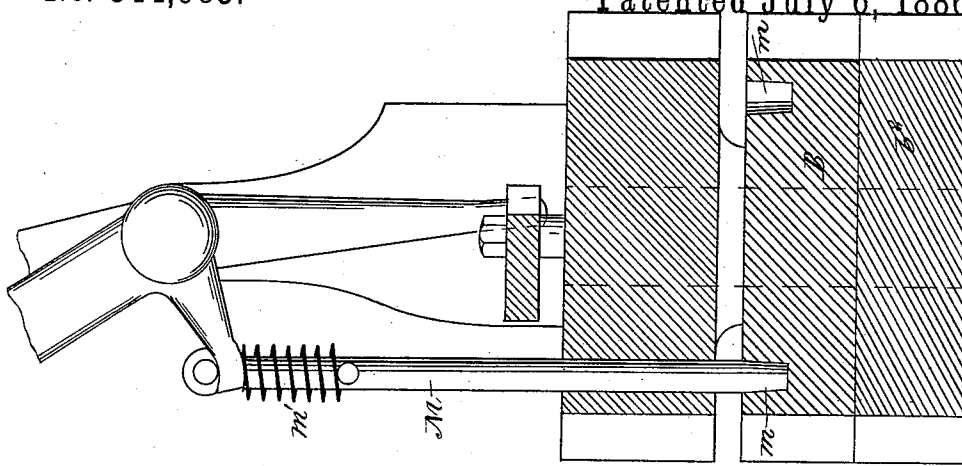

Fig. 17-

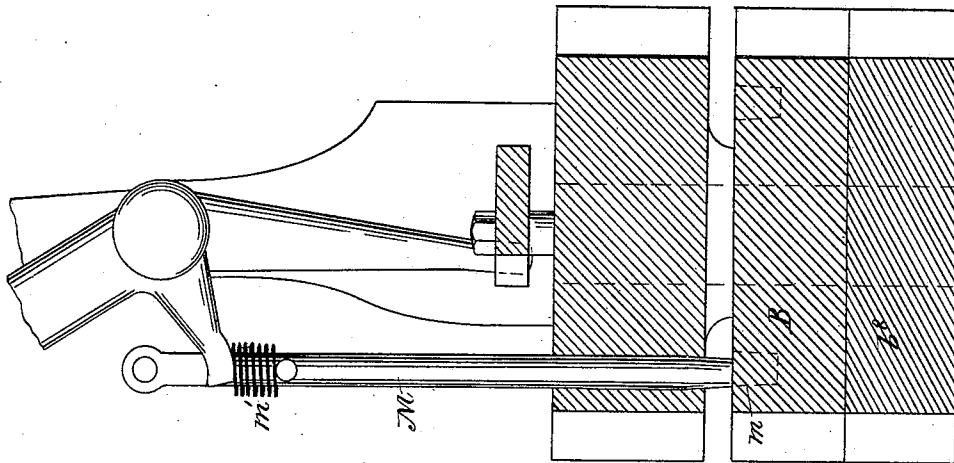

Fig. 16-

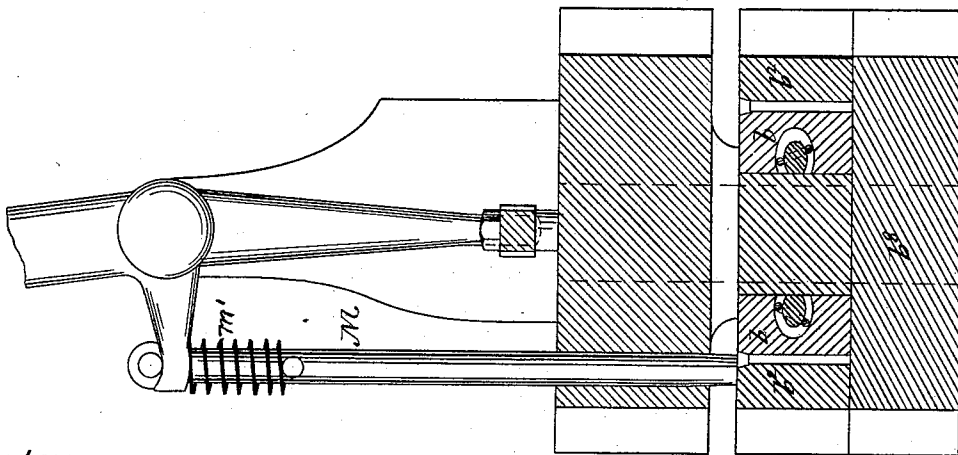

Fig. 15-

WITNESSES

J. M. Dolan.  
Fred. B. Dolan.

INVENTOR  
F. F. Raymond, 2d.

# UNITED STATES PATENT OFFICE.

FREEBORN F. RAYMOND, 2D, OF NEWTON, MASSACHUSETTS.

## NAIL-MAKING MACHINE.

SPECIFICATION forming part of Letters Patent No. 344,985, dated July 6, 1886.

Application filed February 6, 1886. Serial No. 190,968. (No model.)

*To all whom it may concern:*

Be it known that I, FREEBORN F. RAYMOND, 2d, of Newton, in the county of Middlesex and State of Massachusetts, a citizen of the United States, have invented a new and useful Improvement in Nail Making, Distributing, and Driving Machines, of which the following is a full, clear, and exact description, reference being had to the accompanying drawings, forming a part of this specification in explaining its nature.

The invention is an improvement upon that described in my Patent No. 317,199, dated May 5, 1885, and in the application of Towns and Raymond, filed November 27, 1885, Serial No. 184,048, and comprises devices for feeding and pointing wire, and for delivering the pointed blank to a blank or nail carrier, and for receiving the nail-blank from the wire feeding and pointing mechanism and conducting it to the heading devices, jaws, or clamps for holding the wire blank while it is being headed, and a reciprocating or movable bunter or plunger for heading the wire blank while it is held stationary in the jaws or clamping devices; a carrier for transferring headed nails from the heading devices to a position over a nail receiving and delivery block; a nail receiving and delivery block adapted or arranged to receive nails from the carrier and deliver them to a nail-distributor; a nail-distributor adapted to receive nails from the nail receiving and delivery block and transfer them to a nail-carrier, which transfers or carries the nails to the nail-driving devices, and nail-driving devices.

It further relates to means for automatically locating or bringing into proper position the nail in the jaws or clamps regardless of its length.

It further relates to the arrangement, in an organized machine, of devices for making headed nails and for driving them, adapted to act conjointly and automatically; also, to devices for making headed nails, distributing, and driving them, adapted to act conjointly and automatically.

It further relates to various details of construction, all of which will be hereinafter described.

The nail-feeding and nail-pointing devices

are similar to those described in the said application of Towns and Raymond.

Referring to the drawings, Figure 1 is a view in rear elevation of a portion of the machine described in the said Towns and Raymond application containing my improvement. Fig. 2 is a vertical section upon the line  $x x$  of Fig. 1. Fig. 3 is a vertical section upon the line  $v v$  of Fig. 1. Fig. 4 is a horizontal section upon the line  $y y$  of Fig. 1 and a plan of the machine below said line. Fig. 5 is a horizontal section upon the line  $z z$  of Fig. 1 and a plan view of the mechanism below said line. Fig. 6 is a view in vertical section showing the relation of the nail-heading devices to the nail distributing and driving devices. Fig. 7 is a vertical section upon the line  $w w$  of Figs. 2 and 3. Fig. 8 is a section of the central and lower part of the machine, enlarged, to represent the operations of the heading mechanism, the parts having the position which they occupy immediately upon the feeding of the nail-blank by the carrier to the position under the header and before the nail-blank has been moved to bring its head-forming section in proper relation to the head-forming recesses of the die or jaws. Fig. 9 represents the same parts as shown in Fig. 8 at the conclusion of the movement of the nail-lifting device to bring its head-forming end in proper relation to the head-forming dies. Fig. 10 represents the same parts, the jaws or clamps being closed to hold the nail-blank during the operation of heading. Fig. 11 represents the same parts as in Fig. 8 at the conclusion of the heading operation and before the jaws or clamps have been moved to release the headed nail. Fig. 12 represents the parts shown in Fig. 8 after the completion of the operation of the heading devices and upon the opening of the clamp or die. Figs. 13 and 14 are vertical sections on the line  $T T$  of Fig. 1, to illustrate the operation of the devices for stripping or moving the headed nail from the jaws or clamp. Figs. 15, 16, and 17 are views in section upon the line  $s s$  of Fig. 1, to illustrate the operation of the automatic stop for stopping or limiting the movement of the nail-blank carrying or transferring disk after it has been moved by its feeding devices, and for holding it locked in such position.

Fig. 18 is a vertical section of the transferring-disk, showing the use of swaging-dies for forming the points of the nails. Fig. 19 is a view of the nail-blank before heading, and Fig. 20 is a view in elevation of the complete headed nail.

A is the nozzle of the Towns and Raymond nail making and distributing machine. It has a throat or passage, *a*, through which nails or nail-blanks are delivered one by one. Instead, however, of delivering them directly to the nail receiving and delivery block, as described in said Towns and Raymond application, the nails or nail-blanks are delivered one by one to a carrier block or disk, B, which has a number of nail or nail-blank receiving and clamping devices adapted to be brought successively beneath the nozzle A, to receive nails or nail-blanks therefrom, and to carry them in succession to the heading mechanism, and from there to a position from which they are discharged. The disk B is represented as provided with four nail receiving and holding devices. Each device comprises the die-block *b*, fitted to a vertical recess in the disk B, and having the shoulders *b'* for locking the same in place, the movable die-block *b''*, which also fits a recess in the carrier-disk, and has the screw-rods *b'''*, which extend through holes formed in the die-block *b* into holes in the disk B, and serve to fasten it thereon in a manner to permit the horizontal movement of the block *b''* toward the block *b* and in opposition to the springs *b''''*, which act to move the die-block *b''* from the die-block *b*, as hereinafter indicated. Each of the die-blocks *b* has a cavity, *b''''*, enlarged or extended outwardly at *b'''''*, as represented in Fig. 3, which forms the nail-holding recess *b''''''*, and the recess or enlargement in which the head of the nail-blank is upset. Beneath the disk B is an imperforate block or table, *b''''''*, which prevents the nail from leaving the dies while the disk is being revolved and until it reaches position over the hole R, through which the nail is discharged. The disk is intermittently revolved by means of the shaft C, ratchet-wheel *c*, sector-lever *c'*, pivoted at *c''*, carrying the pawl *c'''*, and having teeth *c''''*, formed upon its outer edge, the sector *c''''*, pivoted at *c''''''*, the lever *c'''''''*, pivoted at *c''''''''*, operated by the cam *c'''''''''* and main shaft A'. As there are four nail receiving and holding devices to bring each one successively under the nozzle A, a quarter revolution of the disk is necessary. The nail receiving and holding dies or blocks having received a nail or nail-blank from the nozzle, the disk is advanced to the heading device to bring the nail or nail-blank under the header. After a nail or nail-blank has been moved to this position it is lifted in its holding-recess *b''''''*, so that its head-forming end shall occupy a proper position in relation to the die or head-forming cavity *b''''''*. This is accomplished by means of the lifting-rod D and the header E, the header being moved down by its operating mechanism to a point immediately over the die, so that it acts as a stop

while the lifting-rod D moves the nail upward until its upper end comes in contact with the under surface of the header, when the movable jaw *b''* of the nail receiving and holding device is moved forcibly inward against the stationary jaw *b*, and held locked by the lever F. The lifting-rod D is operated by means of a cam, *d*, on the main shaft, the bell-crank lever *d'*, the rod *d''*, the arm *d'''*, carried thereby, which supports the lifting rod or spindle *d''''*, to which the lifting-rod D is attached. The lifting-rod D has a yielding connection with the support *d''''*, so that it may bring into position nails or nail-blanks of any length; but to lift nails of any length it is necessary that the lifting-rod D shall have a sufficient movement to lift the shortest nail or nail-blank into proper position; consequently when longer nails or nail-blanks are lifted there must be lost motion between the lifting-rod D and its support. This is provided for by allowing the rod *d''* to move in a hole in the bar *d''''* in opposition to the spring *d''''''* after the nail or nail-blank has been moved to place. The lever F is operated by the toggle *f*, the link *f'*, the slide-block *f''*, and cam *f'''*. The header E is held by a suitable slide, *e*, which is reciprocated in the ways *e'* by the combined toggle *e''*, the link *e'''*, the slide-block *e''''*, and the cam *e''''''* on the main shaft A'. The cam is timed so as to depress or move the header E to a position immediately over the die cavity or recess while the lifting-rod D is being operated, so that the nail or nail-blank may be located thereby, but immediately after the lever F has operated to clamp the nail or nail-blank in place it is lifted and immediately moved forcibly downward to head the nail or nail-blank in the cavity *b''''''*. While the header is operating to head a nail or nail-blank, the second nail or nail-blank receiving and holding recess in order is receiving a nail from the nozzle of the nail-making machine; and upon another quarter-revolution of the disk B the headed nail is moved to a position to be discharged, the second nail to the heading devices, and the third nail receiving and holding recess under the nozzle. Immediately upon the outward movement of the lever F the dies *b* *b''* are separated by the die *b''* being forced outward by the spring-pressure. This leaves the headed nail therein free to leave its holding-recess as soon as the recess is brought in line with a hole, R, through which it can pass to the receiving and delivery block. I have arranged to reciprocate in each nail holding and receiving recess and the hole R the rod *g*, which is operated by the lever *g'*, pivoted at *g''*, and reciprocated by the rod *g''* and spring *g'''*, to strip the dies of the nails and force them through the passage R into the nail receiving and delivery block. The disk B is locked automatically at the end of each quarter-revolution by means of the spring-pin M, arranged to enter in succession the holes *m* in the said disk, and which is moved downward by a spring, *m'*, and lifted by the cam

$m^2$  on the main shaft A', and the bent lever  $m^3$ .

The machine described in said Towns and Raymond patent application is adapted to make nails with a V-shaped point, and with this additional heading mechanism the nail is completed—that is, it will have a V-shaped point, a shank of uniform size, and an upset head.

I would state that the heading mechanism described may be used in connection with any mechanism for delivering wire nail-blanks in succession thereto, and that it may also be used in connection with any other nail distributing and driving devices. I would also say that I do not confine myself to the especial form of construction of the die-blocks, or to the especial arrangement or construction of the devices for operating the various parts herein specified.

The receiving and delivery block H, herein referred to and shown in the drawings, is like that described in said Towns and Raymond application. It is provided with an intermittent forward feeding movement and a continuous backward movement, as therein described, to receive the nails from the carrier B, and deliver them to the distributor H'. This distributor is shown in Fig. 6, and it comprises a block,  $h$ , having the holes  $h'$ , arranged to correspond with the holes of the nail-receiving and delivery block H, which are connected by means of the tubes  $h^2$  with the nail-holder  $h^3$ . This nail-holder has nail receiving and holding holes  $h^4$ , which are arranged in the order in which it is desired the nails shall be driven, and the tubes  $h^2$  are bent to connect the holes  $h'$  therewith. The holes in the plate  $h^3$  are represented as closed by the sliding plate  $h^5$ , which is adapted to be moved to open the holes by the pin  $h^6$  on the nail-carrier  $h^7$ , and to be closed by a spring. The nail-carrier  $h^7$  has holes corresponding in number and arrangement with the holes in the block  $h^3$ , and a sliding hole-covering plate,  $h^8$ . It is automatically moved from the block  $h^3$  to the templet  $h^9$  by means of a cam and lever, (not shown,) (see Raymond Patent No. 290,109,) and a plate,  $h^8$ , is automatically moved to open and close the holes of the nail-carrier, as described in Patent No. 316,894. The templet has holes  $h^{10}$ , corresponding in number and arrangement with the holes of the nail-carrier, and it may or may not be moved into and out of position over the work. In Fig. 6 it is represented in position over the heel.

$H^2$  is the cross-head of the machine. It supports or carries the revolving head  $H^3$ , which is automatically revolved by devices similar to those described in the Henderson and Raymond Patent No. 317,647, or in any other desired way. It preferably carries a gang or group of awls and a gang or group of drivers and a top-lift spanker, although it may support the awls and drivers only, or drivers alone, in which case, of course, the head  $H^3$  would not be revolved. The cross-head  $H^2$  is

reciprocated as described in the Raymond Patents Nos. 287,472 and 317,199, or in any other desired way.

I do not confine myself to this especial form of nail distributing and carrying and driving devices, as I may use in connection with the nail making and heading devices any equivalent mechanism for receiving the headed nails automatically and transferring them either singly or in groups to the nail-driving devices.

While I have represented in the drawings the wire feeding and pointing devices of the said Towns and Raymond application, I would state that I may use in lieu thereof any of the well-known wire feeding and severing or wire feeding, severing, and pointing devices, or any equivalent mechanism for feeding the wire automatically and severing it into lengths, and for delivering the severed lengths in successive order to the nail or nail-blank carrying disk or transferer.

I would state that the die-blocks  $b b^2$  may be swaging-dies—that is, they may be formed as represented in Fig. 18, to swage or shape the end of the nail and provide it with a point—and when this form of die is used the point-cutting or forming devices of the said Raymond and Towns application may be dispensed with, if desired.

In operation the wire is fed from a reel by a feeding mechanism automatically to the devices for severing it into lengths and for pointing it, and these severed lengths or blanks are automatically delivered to an intermittingly-revolving disk carrying a series of clamping or holding jaws, which are automatically opened and held open and brought successively in their open condition below the passage or nozzle through which the severed blanks are delivered to receive them one by one and transfer them to other devices, which operate to locate the blank in the jaws or dies, so as to bring their head-forming sections in proper relation to the head-forming portion of the dies, to then close the dies together to hold the nail-blank clamped during the operation of the heading mechanism, and to then head the nail. The carrier is then further operated to transfer each headed nail from the heading mechanism to a position over the nail receiving and delivery block, the dies automatically opening after the heading devices have completed their operations to permit the nail to move downward or be moved downward by a reciprocating stripping device into the hole in the nail receiving and delivery block. This nail receiving and delivery block is arranged to automatically receive the nails thus delivered, and to convey them to a distributor, which automatically arranges them in a form for driving, and delivers them to a nail-carrier, which automatically receives them and carries them to the nail-driving devices, to which it automatically delivers them, and by which they are automatically driven. In other words, the entire operation of the machine, from the time

the wire is fed until the headed nail or nails are driven, is continuous and automatic, and the nail-blanks are automatically severed, pointed, headed, arranged in groups for driving or not, as desired, delivered automatically to the nail-driving devices, and driven.

The machine is especially applicable for any use necessitating the employment of headed nails, and especially for sole and heel nailing and for box nailing.

It will be observed that the nail-carrying devices is so arranged in relation to the nail-blank delivery-passage, the nail-blank-heading devices, and the nail receiving and delivery block that the operations of feeding a nail to one set of dies, of heading a nail-blank in a second set of dies, and of delivering a headed nail from a third set of dies to the nail receiving and delivery block or to an escape-passage, R, are simultaneously proceeding.

Having thus fully described my invention, I claim and desire to secure by Letters Patent of the United States—

1. The combination, in a nailing-machine, with mechanism for delivering wire blanks in successive order to a heading mechanism, of said heading mechanism, comprising the rotary disk B, having the nail receiving and holding jaws  $b b^2$ , the reciprocating header E, and the lever F, substantially as described.

2. The combination, in a nailing-machine, of devices for feeding nails or nail-blanks in succession to a carrier, a carrier for transferring said nails or nail-blanks to heading devices, and a distributor, the heading devices, and a distributor for receiving the nails after they are headed, and for distributing them in arrangement for driving, all substantially as described.

3. The combination of a nozzle, A, having a throat or passage, through which nail-blanks are fed in succession to a nail holder or carrier, said nail holder or carrier consisting of two clamping-jaws adapted to be moved to transfer the nail from the nozzle or passage to the heading mechanism, and said heading mechanism comprising a header, E, and means for operating it, substantially as described.

4. The combination, in a nailing-machine, of the nozzle A, having the passage  $a$ , the disk B, having two or more clamping-jaws,  $b b^2$ , a reciprocating header, E, and the lever F, all substantially as described.

5. The combination, in a nailing-machine, of the nozzle A, having the passage  $a$ , the disk B, having two or more clamping-jaws,  $b b^2$ , one of which is movable in relation to the other, and means for moving the movable jaw against the stationary jaw and locking it in place, and for returning it to its original position upon the release of the holding and locking device, all substantially as described.

6. The combination of the nozzle A, having the passage  $a$ , the revolving disk B, having a series of clamping-jaws,  $b b^2$ , one of which is movable in relation to the other and adapted to be brought successively beneath the header

E and in front of the lever-jaw F, all substantially as described.

7. The combination, in a nailing-machine, of the nozzle A, having the passage  $a$ , the revolving disk B, having a series of clamping-dies,  $b b^2$ , one of which is movable in relation to the other, the lever-jaw F, the header E, and the spring or springs  $b^4$ , all substantially as described.

8. The combination of the nozzle A, having the passage  $a$ , the revolving disk B, carrying the nail-blank-clamping devices  $b b^2$ , and the nail-lifting device D, all substantially as described.

9. The combination of the nozzle A, having the passage  $a$ , the revolving disk B, supporting two or more nail-blank clamping-jaws,  $b b^2$ , the header E, and the reciprocating nail-positioning rod D, all substantially as described.

10. In a nailing-machine, in combination with nail holding or clamping devices, the movable rod D and the reciprocating header E, substantially as described.

11. The combination, in a nailing-machine, of the nail holding or clamping dies, the movable rod D, means for moving it vertically, and for providing it with a yielding movement in relation thereto, all substantially as described.

12. The combination of the rod D, a cam for operating the same, and intermediate connecting mechanism, substantially as specified.

13. The combination of the dies  $b b^2$ , having the nail-heading recess  $b^1$ , with the header E, the sliding block  $e$ , and the compound toggle  $e^2 e^3$ , sliding block  $e^5$ , and cam  $e^6$ , substantially as described.

14. The combination of the die-block  $b$ , the movable die-block  $b^2$ , the lever F, pivoted as described, the toggle  $f$ , the slide-block  $f^2$ , and the cam  $f^3$ , substantially as described.

15. The combination of the nozzle A, having the passage  $a$ , the revolving disk B, supporting two or more nail-blank receiving and holding devices comprising the blocks  $b b^2$ , one of which is movable in relation to the other, the reciprocating header E, the lever F, and the reciprocating nail-stripping rod  $g$ , all substantially as described.

16. The combination of the nozzle A, having the passage  $a$ , the revolving disk B, supporting two or more nail receiving and clamping blocks  $b b^2$ , the header E, and the stop or locking device for locking the disk upon the completion of the feed movement, all substantially as described.

17. The combination of the disk B, the holes  $m$ , the locking-pin M, its operating-spring  $m^1$ , and a lifting-cam,  $d$ , and connecting devices, all substantially as described.

18. The combination of the cam  $d$ , the lifting-rod D, a stripping-rod,  $g$ , the lever  $g^1$ , and the lever  $d^1$ , all substantially as described.

19. The combination of the nozzle A, having the passage  $a$ , the disk B, having two or more nail-blank receiving and clamping de-

vices, the shaft C, the ratchet-wheel *c*, the sector *c'*, having the pawl *c<sup>3</sup>*, the sector *c<sup>3</sup>*, the lever *c<sup>7</sup>*, and the cam *c<sup>9</sup>*, all substantially as described.

5 20. The combination of the nozzle A, having the passage *a*, revolving disk B, carrying two or more nail receiving and clamping jaws, *b b<sup>2</sup>*, one of which is movable in relation to the other, the jaw-operating dies F, the reciprocating header E, the block *b<sup>8</sup>*, having the hole  
10 R and the nail receiving and delivery block H, all substantially as described.

15 21. The combination of devices for automatically feeding nail-blanks to a nail-heading mechanism and for heading the blanks with devices for distributing and arranging them in groups or gangs, substantially as described.

22. The combination of devices for automatically feeding nail-blanks to a nail-carrier, 2c devices for heading the nail-blanks, and an escape passage or throat arranged to receive the headed nail, with a carrier having three or more sets of nail receiving and holding dies or devices arranged to simultaneously receive a 25 nail-blank from the nail-feeding devices, to hold a nail-blank during the operation of the heading device, and to deliver the headed nail, all substantially as described.

FREEBORN F. RAYMOND, 2D.

Witnesses:

M. P. RAYMOND,  
FRED. B. DOLAN.