

(19) **DANMARK**

(10) **DK/EP 2870309 T3**



(12)

Oversættelse af  
europæisk patentskrift

Patent- og  
Varemærkestyrelsen

- 
- (51) Int.Cl.: **E 05 B 27/00 (2006.01)** **E 05 B 35/00 (2006.01)**
- (45) Oversættelsen bekendtgjort den: **2016-10-24**
- (80) Dato for Den Europæiske Patentmyndigheds bekendtgørelse om meddelelse af patentet: **2016-07-20**
- (86) Europæisk ansøgning nr.: **13744421.2**
- (86) Europæisk indleveringsdag: **2013-06-24**
- (87) Den europæiske ansøgnings publiceringsdag: **2015-05-13**
- (86) International ansøgning nr.: **DE2013000356**
- (87) Internationalt publikationsnr.: **WO2014005568**
- (30) Prioritet: **2012-07-03 DE 102012013422**
- (84) Designerede stater: **AL AT BE BG CH CY CZ DE DK EE ES FI FR GB GR HR HU IE IS IT LI LT LU LV MC MK MT NL NO PL PT RO RS SE SI SK SM TR**
- (73) Patenthaver: **Assa Abloy Sicherheitstechnik GmbH, Bildstockstrasse 20, 72458 Albstadt, Tyskland**
- (72) Opfinder: **Matschke, Steffen, William-H.-Tunner-Str. 75, 14167 Berlin, Tyskland**
- (74) Fuldmægtig i Danmark: **Zacco Denmark A/S, Arne Jacobsens Allé 15, 2300 København S, Danmark**
- (54) Benævnelse: **Låsecylinder-nøgle-system**
- (56) Fremdragne publikationer:  
**EP-A1- 1 355 023**  
**EP-A1- 1 870 544**  
**WO-A1-2007/077202**  
**DE-A1- 19 741 118**  
**DE-A1-102009 026 117**  
**US-A1- 2011 048 084**



The invention relates to a lock cylinder - key system, having a cylinder housing in which a cylinder core is rotatably mounted, which cylinder core for its part has a keyway  
5 accommodating an insertable key provided with a profiling of the lateral face, cooperating tumblers which consist of core pin and housing pin being provided in the cylinder core and in  
10 the cylinder housing, which tumblers sense the mechanical coding of the key and given appropriate coding allow a rotation of the cylinder core and thus enable a closing operation.

Lock cylinder - key systems of this kind are generally known.

15 Also known are finger pins which, controlled by features in the key profile, are rotatably mounted in the cylinder core and cooperate with a blocking strip movable radially between cylinder core and lock cylinder housing (DE 10 2009 026 117 A1).

20

The object on which the invention is based is to provide an improved technical copying protection for such a system.

This object is achieved according to the invention in a lock  
25 cylinder - key system, having a cylinder housing in which a cylinder core is rotatably mounted, which cylinder core for its part has a keyway accommodating an insertable key provided with a profiling of the lateral face, cooperating tumblers which consist of core pin and housing pin being provided in  
30 the cylinder core and in the cylinder housing, which tumblers sense the mechanical coding of the key and given appropriate coding allow a rotation of the cylinder core and thus enable a closing operation,

in that the keyway has a profiling corresponding to one of the lateral profilings of the key,

in that the lateral profiling of the keyway has a clearance, into which projects a ball spring-mounted in the key,

5 in that the last core pin in the cylinder core has a groove or cutout, with which a finger pin rotatably mounted in the cylinder core is engageable to maintain the core pin in its locking position, the finger pin being rotatable and disengageable from the groove of the core pin by the ball on  
10 insertion of the key.

Preferred developments will become apparent from the dependent claims and are further explained below.

15 The invention will be explained below with reference to the drawings, in which:

Fig. 1 shows schematically a key inserted partially into the lock cylinder,

20

Fig. 2a shows a section through the lock cylinder according to the line B-B in Figure 1 and

Fig. 2b shows a section according to A-A in Figure 1.

25

Shown here is the locking state, which would be cancelled on further insertion of the key.

In the key 2 is situated a spring-mounted ball 6, 7 which is  
30 seated in the first paracentric profile feature 8 and - in the exemplary embodiment shown here - can move upwards in the direction of the key back.

In a modification of this embodiment, this ball could also be arranged in the key side, provided that the paracentric profile assigned to the key profile in the cylinder core (keyway) can push the ball into the key shank on insertion of  
5 the key.

In the cylinder core 1 the last core pin 3 has a groove 9, in which a finger pin 4 mounted rotatably - parallel to the keyway - engages with the finger 12.

10

This pin has a second finger 10 which is located at the level of the first paracentric profile feature and is "hidden" by the latter.

15 The profile feature of the core is recessed at this location.

If the key is now inserted into the keyway, the paracentric profile of the cylinder core then pushes the ball into the key 1 until the clearance is reached and the ball is pushed  
20 downwards again by the spring 7. On further insertion of the key the ball carries along the second finger 10 of the finger pin 4 and rotates it a little until the core pin 3 is freed and can be pushed down by the key tip, the core pin being displaced so far that it, in cooperation with the customary  
25 housing pin, frees the cylinder core/cylinder housing separating plane and thus its hitherto locking position. On removing the key, the finger pin 4 is rotated by the spring 5 back into the original position again.

30 If there is no ball in the key 2, or at the correct position, then the key 2 cannot be completely inserted into the keyway of the cylinder core 1, since the last core pin 3 is blocked by the finger pin 4 or its finger 12 and thus cannot be pushed down.

The advantage of the solution according to the invention is that it, on the one hand, constitutes a technical key copying protection and, on the other hand, can be integrated into  
5 existing systems.

## **P a t e n t k r a v**

1. Låsecylinder-nøgle-system, med et cylinderhus, i hvilket en cylinderkerne kan lejres drejeligt, hvilken for sit vedkommende har en nøglekanal, der op-  
5 tager en nøgle, der kan indføres og er forsynet med en profilering af sidefladen, hvor der i cylinderkernen og i cylinderhuset er tilvejebragt samarbejdende tumblere, der består af kernestift og husstift, hvilke aflæser nøglens mekaniske kodning og ved en passende kodning tillader en drejning af cylinderkernen og dermed muliggør en låseproces,
- 10 **kendetegnet ved,**  
at låsekanalen har en profilering, der svarer til en af nøglens (2) sideprofileringer (8),  
at nøglekanalens sideprofilering (8) har et frirum (11), som en kugle (6,7), der er lejret fjedrende i nøglen, rager ind i,  
15 at den sidste kernestift (3) i cylinderkernen har en not (9) eller udsparring, med hvilken en fingerstift (4), der er lejret drejeligt i cylinderkernen, kan bringes i indgreb for at fastholde kernestiften (3) i sin blokeringsstilling, hvor fingerstiften (4) ved indføring af nøglen kan bringes i drejeindgreb eller ud af indgreb med kernestiftens not ved hjælp af kuglen (6).
- 20
2. Låsecylinder-nøgle-system ifølge krav 1, **kendetegnet ved,** at fingerstiften (4) ved den øvre ende, der kommer i berøring med kuglen (6), har en finger (10), som rager ind i nøglens (2) profilering.
- 25
3. Låsecylinder-nøgle-system ifølge et af de foregående krav, **kendetegnet ved,** at fingerstiften (4) ved sin nedre ende har en finger (12), som kan bringes i indgreb med noten (9) ved kernestiften (3).
- 30
4. Låsecylinder-nøgle-system ifølge et af de foregående krav, **kendetegnet ved,** at fingerstiften (4) kan bringes ud af indgreb med noten (9) mod kraften fra en fjeder (5).
- 35
5. Låsecylinder-nøgle-system ifølge et af de foregående krav, **kendetegnet ved,** at sideprofileringen (8) er udformet paracentrisk.

**6.** Låsecylinder-nøgle-system ifølge et af de foregående krav, **kendetegnet ved**, at kuglen (6) rager fra nøgleryggen ind i frirummet (11).

Fig. 1

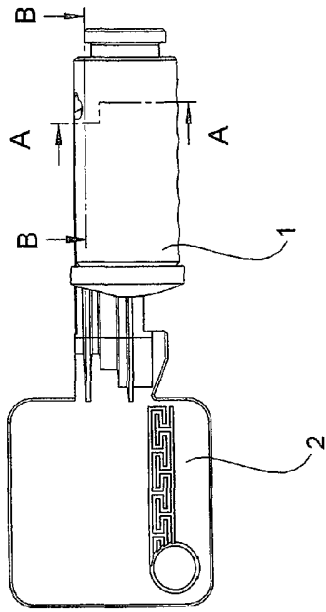

Fig. 2b

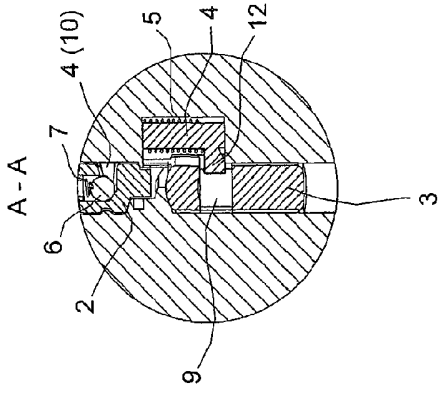

Fig. 2a

