



## VARIABLE FOCUS SPECTACLES

RELATED APPLICATIONS

This application claims the benefit under 35 USC §119(e) of the filing date of United States Provisional Patent Application No. 60/850,742 entitled "Variable Focus Spectacles", filed October 10, 2006.

BACKGROUND OF THE INVENTION

The invention described herein is a new type of variable focus spectacles for presbyopes.

As people age, they gradually lose the ability to focus their eyes at various distances. After about the age of 40, the loss of "accommodation" (as the adjustable focusing ability of humans is called) generally becomes so severe that for almost all people it is not possible to focus both on distant objects and on objects at reading distance, even after distance vision has been corrected. Special types of spectacles have been developed to address this problem: bifocals, trifocals and "PALs" (Progressive Addition Lens). But these types of spectacles have serious deficiencies. They require the user to look through different regions of the lens when trying to focus on objects at different distances from the user. For example, a PAL user must look through the upper portion of the lens when looking at a distant object, and through a very small region in the lower center of the lens when reading a book. Similarly, bifocal users also must look through a small region in the lower portion of the lens to read. Such restrictions are unsatisfactory in many circumstances.

## SUMMARY OF THE INVENTION

Spectacles made in accordance with the presently preferred embodiment of the invention are comprised of

5 i) a "focus module" that includes two variable lens sections, each of which is constructed to provide a user adjustable optical power, and

ii) a pair of preferably detachable prescription lenses placed in front of the variable lens sections, each of which provides an additional fixed optical power.

The prescription lenses in front of the variable lenses are preferably detachable and may be retained by magnets. Alternatively, they may be retained  
10 by other means, such as spring clips or other means. They are called "prescription" lenses here because they preferably include most or all of the optical correction needed by the intended user to view distant objects clearly (the user's "distance prescription"). The correction needed may involve spherical, cylindrical, and/or possibly prismatic components.

15 One advantage of the present invention is that the prescription lenses may be fabricated from standard off-the-shelf finished ophthalmic lens blanks. They may also, of course, be fabricated from semi-finished blanks, or from other starting materials.

The optical powers of the variable lens sections may be adjusted by the user  
20 (preferably both simultaneously) through use of an actuator which is preferably contained within the bridge of the spectacles. The adjustable lens sections provide a variable spherical "ADD" to enable the user to focus on objects at various distances, for example at any distance between infinity and reading distance. The combination of one of the variable lens sections with a prescription lens in front is  
25 sometimes referred to herein as a "lens unit". The prescription lenses are

sometimes called the "front" lenses, even though in some embodiments, as will be mentioned below, these lenses are not furthest away from the user's eyes.

As will be further discussed below, each lens unit is comprised of three lenses (a front lens, a variable liquid lens, and a rear lens). In the presently preferred embodiment of the invention, the front lens incorporates the intended user's distance prescription, including the spherical, cylindrical and prismatic components thereof, but if desired, portions (or possibly all) of the prescription could alternatively be incorporated in the rear lens. Also, the spherical component of the user's prescription, or a portion thereof, could be embodied in the variable liquid lens, if desired.

The focus module, which includes the rear lenses and the variable liquid lenses, contributes a predetermined range of variable spherical optical power to the total, for example zero to +3 diopters. If the front lenses incorporate all of the intended user's distance prescription, then when the focus module is adjusted to provide zero diopters of optical power, the intended user's eyes will be focused on distant objects. If the focus module is adjusted to +3 diopters, the intended user will focus on an object  $1/3$  meters (about 13 inches) away from his or her eyes.

It will be appreciated that the focus module could alternatively be constructed to provide ranges of optical power other than zero to +3 diopters, for example +1 to +3.5 diopters. In that case, the front lenses would preferably be fabricated to provide optical power which is less than the intended user's distance prescription by 1 diopter. Under these conditions, when the focus module is set to provide +1 diopter of optical power, the net optical power of the system will be such that the intended user will be able to view distant objects clearly, and when the focus module is set to provide +3.5 diopters, the spectacles as a whole will be providing +2.5 diopters of optical power more than the intended user's distance

prescription, and hence he or she will be able to see clearly an object 1/2.5 meters (about 16 inches) away from his or her eyes.

In the description of the invention contained herein it is assumed, for simplicity, that the user's two eyes are identical, hence only one optical power need  
5 be discussed to describe the invention. Persons skilled in the art will appreciate, however, that the optical requirements for the two eyes for many users will not be the same, and consequently, the two lens units in spectacles for those persons will not have the same optical characteristics.

The terms "front" and "rear", as used in this document refer to the directions  
10 away from and toward a wearer of the spectacles. Hence, the "rear" lens is the lens closest to the user's eyes. The various parts of the focus module are preferably fastened together by laser welding. Where explicitly shown, typical welds are indicated by solid black triangular areas in the drawings.

Obviously, a complete pair of spectacles normally includes some means for  
15 holding the spectacles in position on the intended user's face. Such means could, for example, consist of temples attached to the focus module, or to the front lenses. The spectacles also preferably include nose pads. For clarity, these elements are not shown in the drawings. However, since appropriate temples and nose pads, as well as methods of incorporating them on spectacles, are well known in the art,  
20 those persons familiar with the art will have no difficulty in including such items in completed spectacles.

The description and drawings herein refer to the focus module as having a "rear" lens, with a liquid lens in front thereof (between the rear lens and the front lens). It will be appreciated that the same goals can be achieved, according to the  
25 principles of the present invention, in an alternate construction wherein the focus module is reversed. That is, where the liquid lens is the rearmost element (the film facing the user's eyes), and where the "rear" lens is located between the liquid lens

and the front lens. Such construction is intended to be covered hereby as well as the preferred construction that is described in detail. Another alternate construction that is intended to be covered hereby uses lens units and focus modules constructed as described above, except that they are constructed to be worn by a user with the “front” lens facing the user’s face, and the “rear” lens facing outward, the liquid lens being in between.

A more complete understanding of the invention may be obtained by reference to the Description of the Invention below, together with the appended drawings.

## BRIEF DESCRIPTION OF THE DRAWINGS

Figure 1 is a front view of the invented spectacles, looking inward toward a where a wearer would be.

5 Figure 2 is a partially exploded cross sectional view of one of the lens units of the spectacles of Figure 1 taken at 2-2 of Figure 1 with the lens unit set for distance viewing.

Figure 3 is a fragmentary detail of Figure 2, the location of the fragment is as denoted by the numeral "3" in Figure 2, the lens unit being adjusted for distance viewing.

10 Figure 4 is a fragmentary detail similar to Figure 3, except that the lens unit is set for close viewing, e.g., reading.

Figure 5 is a fragmentary detail of Figure 2, the location of the fragment is as denoted by the numeral "5" in Figure 2.

15 Figure 6 is an oblique view of the leaf hinge used in connection with the illustrated embodiment of the invention.

Figure 7 is an enlarged fragmentary section of a portion of a representative front lens, showing the detail of a presently preferred groove into which the retaining magnets are inserted, the section being taken in a region where no magnets are located.

20 Figure 8 is an enlarged fragmentary section of a portion of a representative front lens, showing the detail of a presently preferred groove into which the retaining magnets are inserted, the section being taken in a region where a magnet is located.

Figure 9 is a front view of a representative detachable front lens.

## DETAILED DESCRIPTION OF THE INVENTION

Figure 1 depicts a front view of one embodiment of the invention. Two lens units, 10 and 10', are shown, held in relative position by a bridge 12. Within bridge 12, but not shown in detail, is an actuator for adjusting the optical powers of the lens units. The actuator may, for example, be of the type described in US Patent No. 7,008,054, to which reference may be made for more details. Accordingly, the disclosures of US Patent No. 7,008,054 are incorporated herein by reference.

Inasmuch as the two lens units are mirror images of each other, only one will be discussed.

The actuator may be coupled to the rear ring 20 of lens unit 10 through link 13. The link 13 (and its mirror mate on the left lens unit 10' (not shown)) correspond to the links 35 and 36 in the above referenced patent. The link 13 may be attached to the rear ring directly, or may be attached via a tab 11. As described in detail in US Patent No. 7,008,054, adjustment of slider 30 (24 in the referenced patent) will cause the links 13 to move, which, in turn causes the rear ring 20 to move in an arcuate manner, as will be discussed below.

Each lens unit includes three physically distinct lenses: a fixed power front lens 14, a fixed power rear lens 15, and a variable power liquid lens 16. The combination of the three lenses results in a lens unit that is optically equivalent to a single lens such as is commonly used in an ordinary pair of single vision spectacles, except that the lenses in the invented spectacles have adjustable optical powers. In the preferred embodiment of the invention, the front lens is a "prescription" lens in the sense that it is preferably made to include all or almost all of the intended user's distance prescription. This is not a required condition, however; the user's prescription can be realized in the front lens, in the rear lens, or distributed among all three lenses of a lens unit, as may be convenient. For example, the front lens could have no optical power, and the intended user's

distance prescription could be entirely in the rear and liquid lenses, or possibly entirely in the rear lens. In some other case, the rear lens might have zero optical power, and in such case the intended user's distance prescription would be entirely in the front and liquid lenses.

5           Figure 2 shows a cross sectional view of the right lens unit 10 where, for illustrative purposes, the front lens 14 is shown separated from the focus module. A plurality of magnets are attached to the front lens 14, preferably in a groove 24 near the lens periphery (using an adhesive or other means). Four magnets are illustrated, but the number used in practice will depend on the strength of the  
10           magnets and the amount of holding force desired. As illustrated in Figure 1, the magnets are visible from the front of the lens unit. However, as will be discussed below, in the presently preferred embodiment of the invention, the groove 24 is preferably filled with an opaque plastic compound, and the magnets will therefore be hidden; what is seen by an onlooker would be a circular stripe at the groove  
15           location.

          The preferred magnet material is of the rare earth type, such as samarium cobalt or neodymium iron boron because their magnetic properties permit relatively high holding forces. Other magnetic materials are, of course, also possible. The magnets are attracted to the front ring 19 of the focus module (which ring is  
20           preferably fabricated from ferromagnetic material, as for example, 17-4PH steel). The magnetic attraction thereby holds the front lens to the focus module. This arrangement permits the front lenses to be removed for cleaning, for replacement by sun lenses, or for other reasons.

          Figure 7 shows a fragmentary sectional view of a front lens 14, enlarged to  
25           show the detail of a presently preferred shape of the bottom of the magnet retaining groove 24. Since the lens 14 is transparent, the groove 14, and anything contained in it, such as the magnets, will be visible to onlookers. In order to be cosmetically

pleasing, it may be desirable that the magnets be hidden. This can be accomplished by filling the groove with an opaque filler material or potting compound, such as, for example, an epoxy filling 26 containing a colorant, and holding the magnets away from the bottom of the groove while the filler is curing. In the preferred embodiment of the invention, the magnets are held away from the bottom of groove 24 by two shoulders 27. For clarity, the shoulders in Figures 7 and 8 are exaggerated (and not shown in Figures 2-5). Only a very small clearance is needed between the magnets and the bottom of the groove to allow the epoxy to hide the magnets from onlookers, perhaps .002" will be adequate. The actual clearance needed will depend on the opacity of the epoxy. Also, the magnets are preferably a loose fit in the groove, and the filler material will flow around the sides of the magnets, helping to hold the magnets in the groove. The filler material on the sides of the magnets is not shown in the drawings. As mentioned above, for illustrative purposes, the magnets can be seen in Figures 1 and 9, even though in the presently preferred embodiment of the invention only a circular colored stripe will actually be visible to an onlooker.

Rear lens 15 is held by rear ring 20, and the combination is coupled to the front ring 19 through an elastomeric bellows 21, which allows the rear ring to move with respect to the front ring. A thin membrane of transparent distensible plastic film 22, such as saran, is attached to the rear of the front ring, between it and the bellows. For purposes of convenience, the front ring may be referred to as a membrane support member or structure. The space between the film and the rear lens is filled with a clear liquid 16, such as Dow-Corning DC-705 silicone fluid [which liquid (and the film) forms the liquid lens referred to above]. The clear liquid 16 is retained between the rear lens 15 and the film 22 by the elastomeric bellows 21.

A leaf hinge 23 couples the front and rear rings together at a point approximately opposite link 13. For explanatory clarity, the leaf hinge 23 is shown

scabbed onto the circumference of the rings, but in practice, appearance and style may possibly dictate that the hinge be inset or otherwise partially or wholly hidden.

Figures 3 and 4 are fragmentary sectional views of the right lens unit 10 taken near the location of the bridge 12. Figure 3 shows the lens unit adjusted for distance viewing, and Figure 4 shows the lens unit adjusted for near viewing. The difference is that in Figure 3, the link 13 is extended so that rear ring 20 is further from front ring 19, as compared with Figure 4 where the link 13 is retracted and rear ring 20 is closer to front ring 19, both distances being measured near the bridge. As link 13 moves (in response to the user moving slider 30), the rings experience relative rotation (i.e., a clamshell type of motion) about a line near leaf hinge 23.

For purposes of explanation, the rear lens, the filling liquid, and the film are assumed to have approximately the same index of refraction, although this is not an essential requirement. The preferred liquid, Dow-Corning DC-705, one of the preferred lens materials, polycarbonate, and the preferred film, saran, all have indices of refraction about 1.58, and thus satisfy this preference. It is preferred that the front surface of the film 22 have a small positive optical power when the focus module is set for distance viewing, for example, +1 diopter. The reason for this last preference is that the actuating mechanism described in US Patent No. 7,008,054 is capable of exerting force in only one direction, and if an actuator of that type is used, an external restoring force is required to return the system to its distance position. Positive film curvature (which implies tension in the film) can be used to supply at least a part of the needed restoring force. The bellows 21 and/or leaf hinge 23 can each also provide part of the needed force

If the rearmost (i.e., exterior) surface of the rear lens has a negative curvature amounting to an optical power of  $-1$  diopter, the focus module as a whole, when in the position illustrated in Figure 3, will have a net optical power of zero (the  $+1$  diopter optical power of the film surface balancing out the  $-1$  diopter

optical power of the rear surface). Note that if the rear lens and the filling liquid have the same index of refraction, the interface between them has no optical effect, and the optical power of the combination is equal to the sum of the powers of the two exterior surfaces. If the refractive indexes are not the same, the optical power  
5 at the interface may need to be taken into consideration.

When the link 13 is retracted toward the position shown in Figure 4, the liquid will cause the film to bulge forward, increasing the optical power at its bulged surface, and thereby increasing the net optical power of the focus module. If the free area of the film is circular, as is preferred, the additional optical power will be  
10 spherical.

If, as set out in the example described above, the focus module has a net zero optical power when adjusted to the distance position, the front lens would preferably be made to contain the intended user's actual distance refractive demand, including both its spherical and cylindrical components (and possibly  
15 prism). If the focus module were constructed to have a distance optical power other than zero, say, for example, +2 diopters of spherical power, then the front lens would preferably be fabricated with the intended user's prescription, less 2 diopters of sphere.

The term "detachable", referring to the front lens, is intended to mean that  
20 the front lens is removable from the focus module by the wearer without the use of tools. Front lens removal may be desired for a number of reasons, including cleaning, or for replacement with tinted lenses to achieve sun protection. The front lenses of a pair of spectacles may be separate items, as shown, or they may be fastened together by a bridge of their own. They may be attached to the focus  
25 module by magnets, as illustrated, or by spring clips or other means. Even bayonet type connections may be used, if desired.

Referring now to Figure 5, it will be noted that the section of the bellows 21 shown does not have the shape of a bellows, as it does in, e.g., figure 3. At or near the leaf hinge 23, instead of having a bellows shape, the bellows 21 is preferably in the form of a solid piece of rubber. The reason for this is to make it easier to fill the lens unit with liquid. Since there is little or no relative motion between the rings near the leaf hinge, no bellows action is needed, and making the section solid is convenient.

To fill a lens unit, the needle of a hypodermic syringe filled with filling liquid is inserted through the hole 25 in leaf hinge 23, and also through the rubber at that section. Liquid can then be pumped into the lens unit interior, and air correspondingly removed, until the lens unit is completely full. It is preferred that a pencil point, or otherwise non-coring needle, be used so that when the needle is removed, the hole will seal.

When in use, as described above, membrane 22 moves with respect to the front lens 14 as the focus of the spectacles is adjusted. This motion would cause the air pressure between the liquid lens and the front lens to vary if the space between them were sealed. It will be recognized that an increase in air pressure (as would occur when ring 20 is moved closer to the membrane) might dislodge the front lens from the focus unit, or possibly cause other undesirable effects.

Accordingly, it is desirable that a purposeful air leak exist between the front lens and the focus module. In the presently preferred embodiment of the invention, this leak is achieved by having the magnets 18 protrude slightly above the top of the groove 24 and epoxy filling 26. Hence, when the front lens is in place, there will be a small gap between the front lens and the front ring 19 that allows air to pass.

One important class of users of the present invention is expected to be airline pilots. While extremely unlikely, portions of the outer skin of airliners have been known to detach in flight at high altitude. If such were to happen,

pressurization in the cabin could fail suddenly, and the pressure around a pilot could suddenly drop. If a front lens were to detach under such conditions, obvious problems could result. For airline pilots, therefore, the gap between the front lens and the front ring mentioned in the previous paragraph should be adequately sized  
5 to permit sufficient airflow to assure that the air pressure on the rear of the front lens will drop rapidly enough under sudden cabin decompression conditions to assure that the front lenses are not dislodged.

Figure 9 depicts a front view of a lens 14. The lens shape is purposely made obviously non-symmetrical by, for example, including a tab 30, so that a user will  
10 not inadvertently attach a right front lens to the left side of the spectacles, and vice versa. The general shape of the lens away from tab 30 is shown circular in the figure, but it will be recognized that any convenient shape could be used, as dictated by fashion, or other factors.

15

I claim:

1. A variable focus lens which comprises:

a focus unit including:

a membrane support member having an opening therein,

a transparent distensible membrane covering said opening,

5 a first lens mounted to said membrane support member, said first lens being  
movable with respect to said support member,

flexible sealing means extending between said first lens and said membrane  
support member, and

transparent liquid substantially filling the space between said first lens and

10 said transparent distensible membrane within said flexible sealing means;

a second lens; and

securing means holding said second lens to said focus unit.

2. A variable focus lens as recited in claim 1 wherein said second  
lens is detachable.

3. A variable focus lens as recited in claim 2 wherein said securing  
means is comprised of a plurality of magnets.

4. A variable focus lens as recited in claim 3 wherein said plurality of  
magnets are imbedded in said second lens and said focus unit has a rim that is  
magnetically attracted to said magnets.

5. A variable focus lens as recited in claim 1 wherein said first lens is  
attached to said membrane support member by means of a leaf hinge whereby the  
motion of said first lens with respect to said membrane support member is arcuate.

6. A variable focus lens as recited in claim 1 wherein said opening is substantially circular.

7. A variable focus lens as recited in claim 6 wherein said second lens is detachable.

8. A variable focus lens as recited in claim 7 wherein said securing means is comprised of a plurality of magnets.

9. A variable focus lens as recited in claim 8 wherein said plurality of magnets are imbedded in said second lens and said focus unit has a rim that is magnetically attracted to said magnets.

10. A variable focus lens as recited in claim 6 wherein said first lens is attached to said membrane support member by means of a leaf hinge whereby the motion of said first lens with respect to said membrane support member is arcuate.

11. Variable focus spectacles which are comprised of:  
a pair of focus units, each including a first fixed lens having a fixed optical power  
and a liquid lens having an adjustable optical power, said focus units being  
held in spaced relationship by a bridge; and  
5 a pair of second fixed lenses, each held to one of said focus units adjacent said  
liquid lens.

12. Variable focus spectacles as recited in claim 11 wherein said second fixed lenses are detachable.

13. Variable focus spectacles as recited in claim 12 wherein said second fixed lenses are each held to said focus units by a plurality of magnets.

14. Variable focus spectacles as recited in claim 13 wherein said plurality of magnets are imbedded in said second fixed lenses.

15. Variable focus spectacles as recited in claim 11 and further including an actuator for adjusting the optical powers of said focus units.

16. Variable Focus Spectacles which are comprised of:

a first pair of fixed optical power lenses, each having a predetermined optical power;

a pair of membrane support structures, each having an opening therein, each of said membrane support structures being associated with and mounted adjacent to and within the field of view of one of said first pair of fixed optical power lenses, each of said first pair of fixed optical power lenses and its associated membrane support structure being movable with respect to each other;

a membrane attached to each of said membrane support structures across said openings;

a flexible seal extending between each of said first fixed optical power lenses and its associated membrane support structure;

liquid having a predetermined index of refraction substantially filling the spaces between each of said first pair of fixed optical power lenses and its associated membrane support structure within its respective seal; and

a second pair of lenses, each having a predetermined fixed optical power, each being attached to one of said membrane support structures.

17. Variable focus spectacles as recited in claim 16 wherein said second pair of lenses are detachably attached to said membrane support structures.

18. Variable focus spectacles as recited in claim 17 and further including a plurality of magnets permanently attached to each of said second pair of lenses, whereby said second pair of lenses may be magnetically attached to said membrane support structures.

19. Variable focus spectacles as recited in claim 16 wherein said openings are substantially circular.

20. Variable focus spectacles as recited in claim 19 wherein said second pair of lenses are detachably attached to said membrane support structures.

21. Variable focus spectacles as recited in claim 20 and further including a plurality of magnets permanently attached to each of said second pair of lenses, whereby said second pair of lenses may be magnetically attached to said membrane support structures.

22. A detachable lens for variable focus spectacles which comprises:  
a plastic lens having a front face and a rear face;  
a groove in said rear face near the periphery of said lens; and  
a plurality of magnets, each having at least one face, held in said groove by an  
5 adhesive:

23. A detachable lens for variable focus spectacles as recited in claim 22 wherein said one face of at least one of said magnets protrudes from said groove beyond said surface.

24. A detachable lens for variable focus spectacles as recited in claim 22 wherein said magnets are samarium cobalt magnets.

25. A detachable lens for variable focus spectacles as recited in claim 22 wherein said magnets are neodymium iron boron magnets.



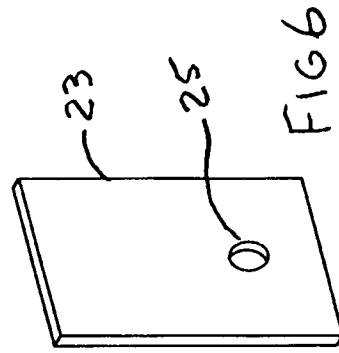
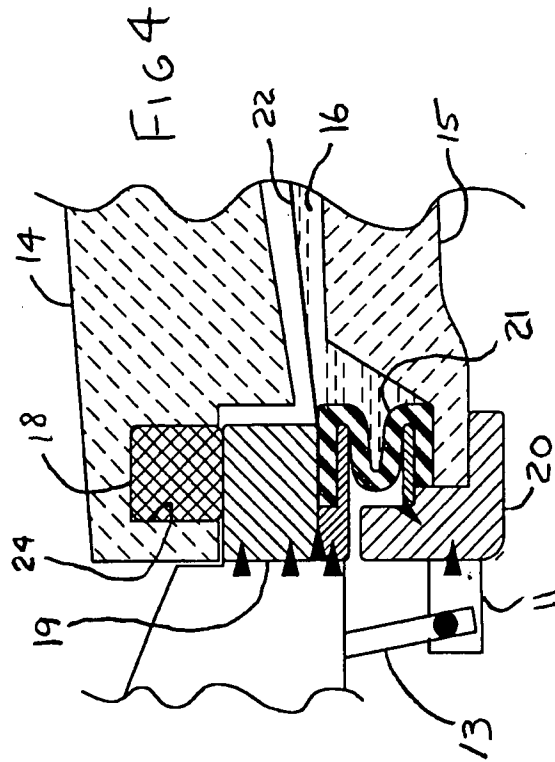
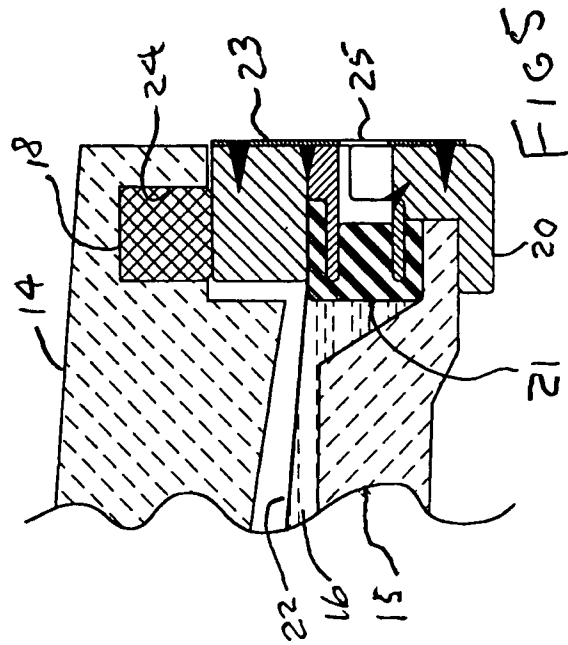

FIG 6

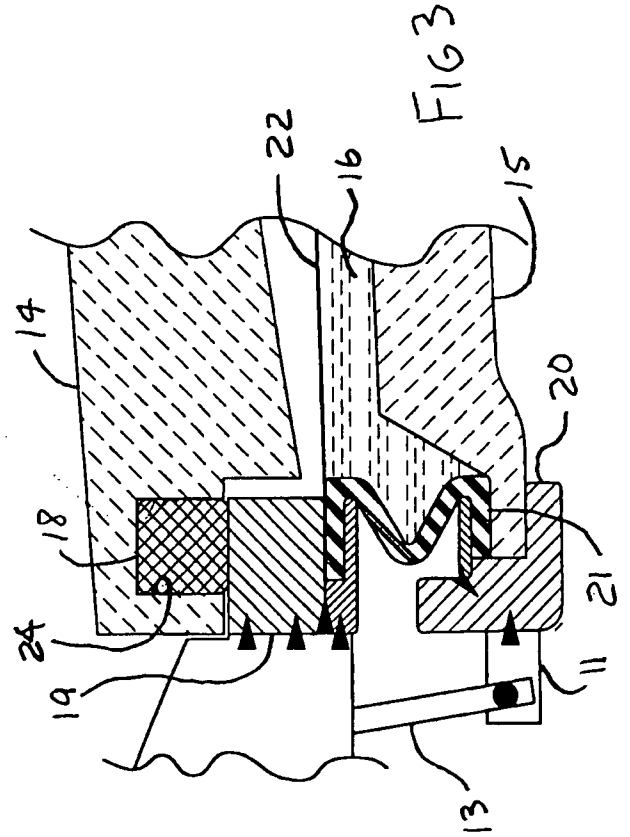

FIG 3

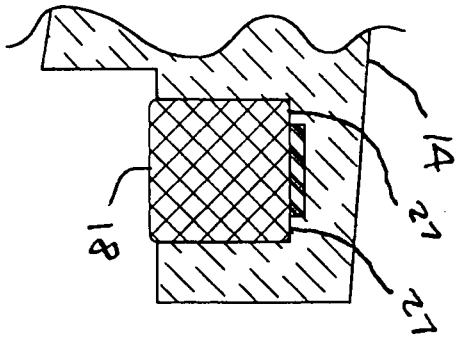

FIG 8

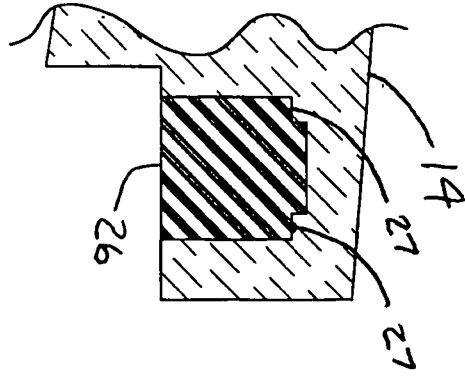

FIG 7

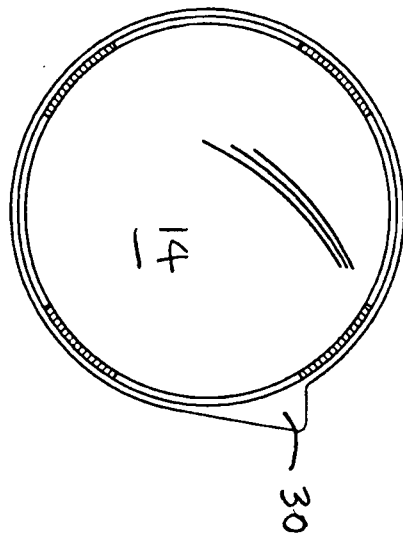

FIG 9