

(19)



(11)

**EP 3 447 229 B1**

(12)

**EUROPEAN PATENT SPECIFICATION**

(45) Date of publication and mention of the grant of the patent:  
**08.07.2020 Bulletin 2020/28**

(51) Int Cl.:  
**E06B 3/263<sup>(2006.01)</sup> E06B 3/273<sup>(2006.01)</sup>**

(21) Application number: **18190682.7**

(22) Date of filing: **24.08.2018**

(54) **THERMALLY INSULATED COMPOSITE PROFILE**  
 ZWISCHENSTÜCK ZUR WÄRMEKOMPENSATION  
 ENTRETOISE DE COMPENSATION THERMIQUE

(84) Designated Contracting States:  
**AL AT BE BG CH CY CZ DE DK EE ES FI FR GB GR HR HU IE IS IT LI LT LU LV MC MK MT NL NO PL PT RO RS SE SI SK SM TR**

- **Mordak, Dariusz**  
**05-152 Czosnow (PL)**
- **Panczyk, Roman**  
**05-152 Czosnow (PL)**

(30) Priority: **25.08.2017 PL 42263417**

(74) Representative: **AOMB Polska Sp. z o.o.**  
**Ul. Emilii Plater 53**  
**21st Floor**  
**00-113 Warsaw (PL)**

(43) Date of publication of application:  
**27.02.2019 Bulletin 2019/09**

(73) Proprietor: **So Easy System Sp. z o.o**  
**05-152 Czosnow (PL)**

(56) References cited:  
**EP-A2- 1 002 924 DE-A1-102004 008 414**  
**DE-A1-102004 038 868 GB-A- 2 413 145**

(72) Inventors:  
 • **Blijweert, Peter**  
**05-152 Czosnow (PL)**

**EP 3 447 229 B1**

Note: Within nine months of the publication of the mention of the grant of the European patent in the European Patent Bulletin, any person may give notice to the European Patent Office of opposition to that patent, in accordance with the Implementing Regulations. Notice of opposition shall not be deemed to have been filed until the opposition fee has been paid. (Art. 99(1) European Patent Convention).

**Description****Field of the invention**

5 **[0001]** The invention relates to a thermally insulated composite profile, in particular for windows, doors, facades and the like, comprising at least one external aluminium profile and at least one internal aluminium profile, connected together by means of at least two thermal compensation spacers arranged essentially in parallel to each other, wherein each spacer is made of at least two materials of different hardness. The composite profile according to the invention provides significant improvement in terms of thermal insulation of the entire window or door systems, but also improved mechanical strength by increasing its stiffness in the direction perpendicular to the spacers (when viewed in a cross-section) which as such are generally elastic. This allows to maintain the general advantage of two thermal compensation spacers expanding and shrinking temperature-wise independently from one another and thus preventing the window/door frames from deformations in the direction parallel to the spacers (again - viewed in a cross-section), while at the same time providing improved mechanical strength of the profile in the direction perpendicular to the spacers.

**Background art**

20 **[0002]** Thermal spacers in form of strip elements are used in the production of insulated aluminium profiles and serve to increase thermal insulation of aluminium profiles used for manufacturing window and door structures. Low thermal conductivity of the thermal spacers in the profiles used to make window and door constructions prevents cold air penetrating indoor spaces in winter (freezing) and, likewise, hot air in summer (excessive heating).

**[0003]** The thermal spacer, which generally is formed as a longitudinal strip element, is assembled with the external and internal aluminium profiles by crimping said aluminium profiles at the edge regions along the longer edges of the strip element on both sides.

25 **[0004]** Examples of thermal spacers commonly used in aluminium joinery systems are disclosed e.g. in the Polish patent application P.388324 and in the protection rights for utility models PL 66 696 Y1 and PL 66 697 Y1.

30 **[0005]** Thermal spacers made of polymer materials not only have good thermal insulation properties, but also high load capacity and are designed to carry access loads together with (external and internal) aluminium profiles. The material most commonly used for producing thermal spacers is polyamide (PA) reinforced with glass fibre, but some other materials are also used, e.g. acrylonitrile-butadiene-styrene (ABS) terpolymer, polyethylene terephthalate (PET), or Noryl™ (amorphous mix of poly(phenylene oxide), poly(phenylene ether) and polystyrene).

**[0006]** Apart from the material, thermal spacers may vary in shape: straight, omega-shaped (in cross-section), chamber type, complex and other.

35 **[0007]** Ready-made window and door constructions made of aluminium profiles mounted as external structures are exposed to atmospheric conditions (heating and cooling). High temperatures (temperature difference between the external and internal aluminium profiles) make the external aluminium profile extend more than the internal one, thus exposing the profile to deformations (the so-called bimetallic effect, generally described in relation to elements composed of two metals having different thermal expansion properties in specific temperature conditions, but present alike in structures made of one metal whose various parts are exposed to various temperatures). This effect is particularly noticeable when using structures facing south, painted in dark colours and with their frame filled with an aluminium panel instead of glass. A similar effect is also noticeable in winter (cooling of the external aluminium profile). Due to the different expansion properties of the external and internal aluminium profiles composing the window and door structures an arching is generated thereby depriving the structure of its tightness.

40 **[0008]** One of the known methods for eliminating deformations of composite aluminium profiles is to use special compensation spacers with local notches of various shapes (rectangles, triangles, circles, etc.) that to some extent compensate the stress between the external and internal aluminium profiles. Such solutions are disclosed e.g. in the U.S. Patent No. 7913470 and in the U.S. Patent Application US 2010/0115850. Notches of the spacer are masked with a cover integrated with the spacer, which results in aesthetic appearance without affecting the spacer operation.

**[0009]** EP 1 002 924 A2 and DE 10 2004 038868 A1 both disclose all the features of the preamble of claim 1.

45 **[0010]** Further, EP 1002924 A2 discloses a thermally insulated composite profile, in particular for windows, doors, facades and the like, with at least two profiles, preferably made of metal, connected by an insulating slat having distal regions at the longitudinal edge, with which the insulating slat is cramped by the profiles. An intermediate region located between these distal regions and having greater elasticity than these distal regions.

50 **[0011]** Yet further, DE 10 2004 038868 discloses a thermally insulated composite profile, in particular for windows, doors, facades and the like, with at least two metallic profiles connected by thermally insulating elements and composed of two materials of different strength. Similarly as in EP 1002924 A2, there are two distal regions at the longitudinal edge and an intermediate region located therebetween and having lower strength than the distal regions.

55 **[0012]** Despite their known advantage in terms of relatively good compensation of vertical shear/deformation forces

(i.e. acting in the direction parallel to the spacers, when viewed in a cross-section) resulting from temperature differences between the external and internal aluminium profile of the system, the thermal compensation spacers, which as such are generally elastic, show much lower stiffness in case of horizontal forces (i.e. acting in the direction perpendicular to the spacers, when viewed in a cross-section). Window/door composite profiles including customary thermal compensation spacers are much less stable when exposed to strong winds (this included both suction and pressure forces, depending on the actual configuration and conditions) and unseal much faster. It is also quite difficult to assemble such profiles, since e.g. cutting and milling operations require additional stabilizing the processed profiles in tooling equipment.

**[0013]** Given that aluminium joinery systems are commonly used in a variety of climates, including often very large structures (skyscrapers, industrial buildings, large commercial and service buildings, public utility buildings), there is a constant need for new solutions that would allow for the best possible stress compensation and compensation of the resulting deformations of aluminium profiles, while maintaining the simplest possible and economically attractive methods for manufacturing spacers and assembling ready systems, as well as providing profiles showing improved overall mechanical strength.

## Summary of the invention

**[0014]** The aim of the present solution was to overcome the problems referred to above and associated with the use of known solutions, and in particular to provide good stress compensation between the external and internal aluminium profiles in case of large temperature differences between the environments on the external and internal profile sides, and the simplest possible method for manufacturing thermal spacers and installation of spacers in aluminium joinery systems. Furthermore, the present invention aimed to improve the overall strength and static performance of the entire thermally insulated composite profile, which is particularly relevant in case of large glass panes and extreme performance conditions (i.e. windy areas).

**[0015]** Accordingly, the present invention relates to a thermally insulated composite profile, in particular for windows, doors, facades and the like, comprising at least one external aluminium profile and at least one internal aluminium profile, connected together by means of at least two thermal compensation spacers arranged essentially in parallel to each other. Each spacer is made of:

(a) at least two materials of different hardness and is shaped as an elongated strip comprising two distal edge regions along its both longer edges, whereby the distal edge regions are adapted to be crimped in the external and internal aluminium profiles and are made of a hard polymer material; and

(b) at least one intermediate elastic region made of soft and elastic polymer material being provided between the edge regions.

**[0016]** The composite profile according to the invention comprises at least one aluminium fin arranged between the spacers and spanning them together.

**[0017]** The presence of at least one aluminium fin spanning the spacers together provides significant improvement in terms of thermal insulation of the profiles (and consequently the entire window or door systems), but also improved mechanical strength of the profile by increasing its stiffness in the direction perpendicular to the spacers (when viewed in a cross-section) which as such are elastic. This allows to maintain the general advantage of two thermal compensation spacers expanding and shrinking temperature-wise independently from one another and thus preventing the profile elements from deformations in the direction parallel to the spacers (again - viewed in a cross-section), but at the same time it provides improved mechanical strength of the profile in the direction perpendicular to the spacers. This facilitates the installment of fittings such as locks and coupling plates prevents from deformation of profiles during the assembly and prefabrication steps, i.e. cutting, milling and joining the profile together in corners.

**[0018]** Preferably, the aluminium fin is shaped as an elongated strip comprising distal edge regions along its both longer edges, said distal edge regions being engaged with corresponding grooves formed on the sides of the thermal compensation spacers facing each other. In particular, the distal edge regions of the aluminium fin can be clicked and/or slid in the grooves of the spacers.

**[0019]** Preferably, the composite profile comprises at least two aluminium fins arranged in parallel to each other between the spacers and spanning them together. This further contributes not only of to the increased stiffness of the entire composite profile in the direction perpendicular to the spacers but also to significant improvement of thermal insulation properties. Compared to known reinforcement fins of polyamide (used exclusively in combination with normal thermal spacers, not showing the compensating effect), the aluminium fins are both light and rigid. Further, due to its highly reflective properties, the composite profiles according to the present invention, comprising aluminium fins, show superior thermal insulation properties compared to the prior art profiles. In the preferred embodiment including two aluminium fins arranged in parallel to each other between the spacers and spanning them together the prior art three-

chamber profile structure is replaced with five-chamber one, and the high reflectance of aluminium fins is particularly effective in reducing thermal losses due to emission or radiation.

**[0020]** In one preferred embodiment, at least one thermal compensation spacer consists of three regions extending longitudinally over its entire length, whereby the two distal edge regions are made of a hard polymer material, and an intermediate elastic region located between these distal edge regions is made of soft and elastic polymer material

**[0021]** In another preferred embodiment, at least one thermal compensation spacer consists of five regions extending longitudinally over its entire length, whereby the two distal edge regions and one middle region are made of a hard polymer material, and between each of the distal edge regions and the middle region there is an intermediate elastic region made of soft and flexible polymer material.

**[0022]** In yet another preferred embodiment, at least one thermal compensation spacer has closed air chambers at least on a portion of its length.

**[0023]** In a further preferred embodiment, at least one thermal compensation spacer on one or both sides has additional projections for attaching rails or caps.

**[0024]** The hard polymer material is preferably selected from polyamide (PA), acrylonitrile-butadiene-styrene (ABS) terpolymer and poly(ethylene terephthalate) (PET), while the soft and flexible polymer material is preferably a thermo-plastic elastomer.

**[0025]** According to the present invention, each thermal spacer is composed of two components of different hardness and is produced by co-extrusion, i.e. extrusion of several layers which may differ in structure and colour. As in the prior art solutions, the presence of flexible middle part(s) of thermal compensation spacers combined with more rigid external parts thereof crimped in the external and internal aluminium profiles allows to compensate the differences in the displacement of external and internal profiles resulting from different temperatures affecting the external and internal parts of the window and door structures. The co-extrusion process enables to obtain a multi-component spacer showing required rigidity and strength as well as to maintain the desired tolerances of linear and cross-sectional dimensions. The thermal spacers used in the thermally insulated composite profiles according to the invention can be manufactured in all the currently commercially available shapes, i.e. straight, omega-shaped (in cross-sectional view), in a three-dimensional and chambered variants, with caps, in complex systems, etc.

#### Brief description of the drawings

**[0026]** The invention will now be presented in greater detail in preferred embodiments, with reference to the accompanying drawings, in which:

fig. 1 is a cross-sectional view of thermally insulated composite profile according to one embodiment of the invention;

fig. 2 is a cross-sectional view of a thermally insulated composite profile according to another embodiment of the invention;

fig. 3a is a cross-sectional view of one variant of a thermally insulated composite profile having no reinforcing element spanning the thermal compensation spacers;

fig. 3b is a cross-sectional view of one variant of a thermally insulated composite profile having a slid-in polyamide reinforcing elements spanning the thermal compensation spacers;

fig. 3c is a cross-sectional view of one variant of a thermally insulated composite profile according to the invention;

fig. 4a is a cross-sectional view of a second variant of a thermally insulated composite profile having no reinforcing element spanning the thermal compensation spacers;

fig. 4b is a cross-sectional view of a second variant of a thermally insulated composite profile having a slid-in polyamide reinforcing elements spanning the thermal compensation spacers;

fig. 4c is a cross-sectional view of a second variant of a thermally insulated composite profile according to the invention;

fig. 5a is a cross-sectional view of a third another variant of a thermally insulated composite profile having no reinforcing element spanning the thermal compensation spacers;

fig. 5b is a cross-sectional view of a third variant of a thermally insulated composite profile having a slid-in polyamide

reinforcing elements spanning the thermal compensation spacers;

fig. 5c is a cross-sectional view of a third variant of a thermally insulated composite profile according to the invention;

5 fig. 6a is a cross-sectional view of a thermally insulated composite profile according to an exemplary embodiment of the invention;

fig 6b is a cross-sectional view of a thermally insulated composite profile arrangement similar to that of fig. 6a, but without the reinforcing aluminium fins spanning the thermal compensation spacers;

10 fig. 7 is a cross-sectional view of straight-shaped thermal compensation spacers in two embodiments of the invention;

fig. 8 is a cross-sectional view of omega-shaped thermal compensation spacers in two embodiments of the invention;

15 fig. 9 is a cross-sectional view of chamber type thermal compensation spacers in four embodiments of the invention;

fig. 10 is a cross-sectional view of thermal compensation spacers with caps in six embodiments of the invention;

20 fig. 11 is a top view of a thermal spacer fragment in one embodiment of the invention;

fig. 12 is a top view of a thermal spacer fragment in another embodiment of the invention;

#### Detailed description of preferred embodiments

25 **[0027]** In the figs. 1-6b the regions made of hard polymer material are marked with oblique hatching, while the regions made of soft and flexible polymer material are marked as solid dark areas.

**[0028]** Fig. 1 in a cross-sectional view shows an embodiment of the thermally insulated composite profile according to the invention. The profile of this embodiment comprises an external aluminium profile 1 and an internal aluminium profile 2, connected together by means of two thermal compensation spacers 3, 4 arranged essentially in parallel to each other. Each spacer 3, 4 is made of two materials of different hardness and is shaped as an elongated strip comprising two distal edge regions 5 along its both longer edges. These distal edge regions 5 made of a hard polymer material (represented by oblique hatching) are crimped in the external and internal aluminium profiles 1, 2. In addition to distal edge regions 5 each spacer 3, 4 comprises a middle region 10 made of the same hard polymer material and two intermediate elastic regions 6, each provided between a distal edge region 5 and a middle region 10. The intermediate elastic regions are made of soft and elastic polymer material. Two aluminium fins 7 are arranged in parallel to each other between the spacers 3, 4 and spanning the latter together. Each of the aluminium fins 7 is shaped as an elongated strip comprising distal edge regions 8 along its both longer edges. These distal edge regions 8 of each of the fins 7 are engaged with corresponding grooves 9 formed on the sides of the thermal compensation spacers 3, 4 facing each other. In the embodiment shown in fig. 1 one distal edge region 8 of each fin 7 is clicked in the corresponding groove 9 of the respective spacer 3, 4 (right hand distal edge regions 8 in fig. 1), while the opposite distal edge region 8 of each fin 7 is slid in the corresponding groove 9 of the respective spacer 3, 4 (left hand distal edge regions 8 in fig. 1).

**[0029]** Fig. 2 shows in a cross-sectional view another embodiment of the thermally insulated composite profile according to the invention. This embodiment is very much alike the one of fig. 1, except for the fact that all the distal edge regions 8 of both aluminium fins 7 are clicked in the corresponding grooves 9 of the spacer 3, 4.

45 **[0030]** Figs. 3a-3c show cross-sectional views of three variants (1.1, 2.1 and 3.1, respectively) of a thermally insulated composite profile in a frame-sash arrangement. All these variants are generally alike, since they comprise internal and external aluminium profiles 1, 2, thermal compensation spacers 3, 4 of the same shape and composed of the same hard polymer material parts (i.e. the distal edge regions 5 and middle regions 10) and soft and elastic polymer material parts (i.e. the intermediate elastic regions). They differ from each other by a single differentiating feature associated with the presence and properties of the reinforcing elements spanning the thermal compensation spacers 3, 4. More specifically, the profile of variant 1.1 (fig. 3a) has no such reinforcing element at all, the profile of variant 2.1 (fig. 3b) has a slid-in polyamide reinforcing elements spanning the thermal compensation spacers 3, 4, and the profile of variant 3.1 (fig. 3c) has clicked-in aluminium fins 7 spanning the thermal compensation spacers 3, 4.

55 **[0031]** Figs. 4a-4c show cross-sectional views of another three variants (1.2, 2.2 and 3.2, respectively) of a thermally insulated composite profile in a frame-treshold arrangement. As in case of variants 1.1, 2.1 and 3.1 (shown in figs. 3a-c) all these variants 1.2, 2.2 and 3.2 are generally the same, except for a single differentiating feature, namely the presence and properties of the reinforcing elements spanning the thermal compensation spacers 3, 4. More specifically, the profile of variant 1.2 (fig. 4a) has no such reinforcing element at all, the profile of variant 2.2 (fig. 4b) have a slid-in

polyamide reinforcing elements spanning the thermal compensation spacers 3, 4, and the profiles of variant 3.2 (fig. 4c) have clicked-in aluminium fins 7 spanning the thermal compensation spacers 3, 4.

[0032] Figs. 5a-5c show cross-sectional views of yet another three variants (1.3, 2.3 and 3.3, respectively) of a thermally insulated composite profile in a movable central post arrangement. As in case of variants 1.1, 2.1 and 3.1 (shown in figs. 3a-c) or variants 1.2, 2.2, and 3.2 (shown in figs. 4a-c), all these variants 1.3, 2.3 and 3.3 are generally the same, except for a single differentiating feature, namely the presence and properties of the reinforcing elements spanning the thermal compensation spacers 3, 4. More specifically, the profile of variant 1.3 (fig. 5a) has no such reinforcing element at all, the profile of variant 2.3 (fig. 5b) have a slid-in polyamide reinforcing elements spanning the thermal compensation spacers 3, 4, and the profiles of variant 3.3 (fig. 5c) have clicked-in aluminium fins 7 spanning the thermal compensation spacers 3, 4.

[0033] In fig. 6a and 6b two arrangements of thermally insulated composite profiles are shown in cross-sectional views. These arrangements are essentially the same, except for the presence of two aluminium fins 7 spanning the thermal compensation spacers 3, 4 in an exemplary embodiment of the invention shown in fig. 6a and the lack of such fins (or any other reinforcing element spanning the thermal compensation spacers 3, 4) in the profile shown in fig. 6b. Both arrangements were used for mechanical strength tests (described in a greater detail below). The vertical load was applied in the direction shown by the arrow.

[0034] In the figs. 7-12 discussed in detail below several preferred embodiments of thermal compensation spacers 3, 4 are shown. In each of these figures the regions made of hard polymer material are marked with horizontal hatching, while the regions made of soft and flexible polymer material are marked with oblique hatching.

[0035] Fig. 7 is a cross-section of two embodiments of straight-shaped thermal compensation spacers 3, 4, with the embodiment with one intermediate elastic region 6 of soft and flexible polymer material being shown at the top, and below there is an embodiment with two such regions 6 divided by a middle region 10 of hard polymer material.

[0036] Fig. 8 is a cross-section of two embodiments of omega-shaped thermal compensation spacers 3, 4, whereby - similarly to fig. 4 - the embodiment with one intermediate elastic region 6 of soft and flexible polymer material is shown at the top, and below there is an embodiment with two such regions 6 divided by a middle region 10 of hard polymer material.

[0037] Fig. 9 is a cross-section of four embodiments of chamber type thermal compensation spacers 3, 4, varying in number and arrangement of chambers and regions of hard polymer material and of soft and flexible polymer material.

[0038] Fig. 10 is a cross-section of six embodiments of thermal compensation spacers 3, 4 with caps 11, showing various ways of fastening the caps 11 and varying in number hard polymer material regions and soft and flexible polymer material regions.

[0039] Fig. 11 is a top view of a thermal spacer fragment in the embodiment with one intermediate region of soft and flexible polymer material, and fig. 12 is an analogue view of the embodiment with two such regions dividing the middle region of hard polymer material.

#### Heat transfer coefficient determination

[0040] For all nine composite profile variants 1.1-3.3 (shown in fig. 3a-5c, respectively) heat transfer coefficient for frame  $U_f$  [W/(m<sup>2</sup>·K)] was determined according to the standard PN-EN-10077-2\_2017-10E. The results are presented in table 1 below.

Table 1: Heat transfer coefficient for frame  $U_f$  [W/(m<sup>2</sup>·K)] values for system variants 1.1-3.3

System variant no.	Fig. no.	$U_f$ [W/(m <sup>2</sup> ·K)]
1.1	3a	1.970
2.1	3b	1.516
3.1	3c	1.365
1.2	4a	1.975
2.2	4b	1.587
3.2	4c	1.457
1.3	5a	1.991
2.3	5b	1.566
3.3	5c	1.434

[0041] From the results shown in the table 1 above it is clear that the variant 3.1., 3.2, and 3.3 exemplifying the claimed invention have superior (i.e. significantly lower)  $U_f$  values than corresponding variants 1.1, 1.2, 1.3 bearing no reinforcing element that would span the thermal spacers as well as the variants 2.1, 2.2 and 2.3 having polyamide reinforcement slid-in fins spanning these thermal spacers.

### Mechanical strength test

[0042] Mechanical strength test was performed according to the standard PN-EN ISO 7438: 2016 for four samples (1-4) exemplifying two configurations shown in figs. 6a and 6b, respectively. Each sample was tested twice. The results are presented in table 2 below.

Table 2: mechanical strength values for the samples 1-4

Sample no.	Fig. no.	Sample length [mm]	Deflection [mm]	Load [kN]
1	6a	500	10	0.73 0.88
2	6a	1000	10	1.45 1.55
3	6b	500	10	0.078 0.093
4	6b	1000	10	0.16 0.18

[0043] The results presented in the table 2 clearly show that samples 1 and 2 exemplifying the claimed invention (i.e. comprising two parallel aluminium fins 7 spanning the two thermal spacers 3, 4) show much greater mechanical strength (much higher load is required to obtain the same deflection) than the samples 3 and 4 having no reinforcing elements spanning the thermal spacers 3, 4.

### Claims

1. A thermally insulated composite profile, in particular for windows, doors, facades and the like, comprising at least one external aluminium profile (1) and at least one internal aluminium profile (2), connected together by means of at least two thermal compensation spacers (3, 4) arranged essentially in parallel to each other, wherein each spacer (3, 4) is made of:
  - (a) at least two materials of different hardness and is shaped as an elongated strip comprising two distal edge regions (5) along its both longer edges, whereby the distal edge regions (5) are adapted to be crimped in the external and internal aluminium profiles (1, 2) and are made of a hard polymer material; and
  - (b) at least one intermediate elastic region (6) made of soft and elastic polymer material being provided between the edge regions (5),

**characterised in that** at least two aluminium fins (7) are arranged in parallel to each other between the spacers (3, 4) and spanning them together, each aluminium fin (7) is shaped as an elongated strip comprising distal edge regions (8) along its both longer edges, said distal edge regions (8) being clicked and/or slid in corresponding grooves (9) formed on the sides of the thermal compensation spacers (3, 4) facing each other, whereby each distal edge region (8) of each aluminium fin (7) forms an elastic joint with the corresponding groove (9).
2. The composite profile according to claim 1, wherein at least one thermal compensation spacer (3, 4) consists of three regions extending longitudinally over its entire length, whereby the two distal edge regions (5) are made of a hard polymer material, and an intermediate elastic region (6) located between these distal edge regions (5) is made of soft and elastic polymer material.
3. The composite profile according to claim 1 or 2, wherein at least one of the two thermal compensation spacers (3,

4) consists of five regions extending longitudinally over its entire length, whereby the two distal edge regions (5) and one middle region (10) are made of a hard polymer material, and between each of the distal edge regions (5) and the middle region (10) there is an intermediate elastic region (6) made of soft and flexible polymer material.

- 5 4. The composite profile according to any of claims 1-3, wherein at least one thermal compensation spacer (3, 4) has closed air chambers at least on a portion of its length.
5. The composite profile according to any of claims 1-4, wherein at least one thermal compensation spacer (3, 4) on one or both sides has additional projections for attaching rails or caps (11).
- 10 6. The composite profile according to any of claims 1-5, wherein the hard polymer material is selected from polyamide (PA), acrylonitrile-butadiene-styrene (ABS) terpolymer and poly(ethylene terephthalate) (PET).
- 15 7. The composite profile according to any of claims 1-6, wherein the soft and flexible polymer material is a thermoplastic elastomer.

### Patentansprüche

- 20 1. Wärmeisoliertes Verbundprofil, insbesondere für Fenster, Türen, Fassaden und dergleichen, umfassend mindestens ein äußeres Aluminiumprofil (1) und mindestens ein inneres Aluminiumprofil (2), die durch mindestens zwei im wesentlichen parallel zueinander angeordnete Wärmekompensationsabstandshalter (3, 4) miteinander verbunden sind, wobei jeder Abstandhalter (3, 4) besteht aus:
- 25 (a) mindestens zwei Materialien unterschiedlicher Härte und ist als länglicher Streifen geformt, der zwei distale Randbereiche (5) entlang seiner beiden längeren Kanten umfasst, wobei die distalen Randbereiche (5) in die äußeren und inneren Aluminiumprofile (1, 2) einfaltbar sind Profile (1, 2) und aus einem harten Polymermaterial bestehen; und
- (b) mindestens ein elastischer Zwischenbereich (6) aus weichem und elastischem Polymermaterial, der zwischen den Randbereichen (5) vorgesehen ist;
- 30 **dadurch gekennzeichnet, dass** mindestens zwei Aluminiumrippen (7) parallel zueinander zwischen den Abstandshaltern (3, 4) angeordnet sind und diese zusammen überspannen, jede Aluminiumrippe (7) als länglicher Streifen mit distalen Randbereichen (8) entlang seiner beiden längeren Kanten geformt ist, wobei die distalen Randbereiche (8) in entsprechende Nuten (9), die auf den einander zugewandten Seiten der Wärmekompensationsabstandshalter (3, 4) ausgebildet sind, eingeklickt und/oder
- 35 eingeschoben werden, wobei jeder distale Randbereich (8) jeder Aluminiumrippe (7) ein elastisches Gelenk mit der entsprechenden Nut (9) bildet
- 40 2. Verbundprofil nach Anspruch 1, wobei mindestens ein Wärmekompensationsabstandhalter (3, 4) aus drei Bereichen besteht, die sich in Längsrichtung über seine gesamte Länge erstrecken, wobei die beiden distalen Randbereiche (5) aus einem harten Polymermaterial hergestellt sind, und ein zwischen diesen distalen Randbereichen (5) befindlicher elastischer Zwischenbereich (6) aus einem weichen und elastischen Polymermaterial hergestellt ist
- 45 3. Verbundprofil nach Anspruch 1 oder 2, wobei mindestens einer der beiden Wärmekompensationsabstandshalter (3, 4) aus fünf Bereichen besteht, die sich in Längsrichtung über seine gesamte Länge erstrecken, wobei die beiden distalen Randbereiche (5) und ein mittlerer Bereich (10) aus einem harten Polymermaterial hergestellt sind und zwischen jedem der distalen Randbereiche (5) und dem mittleren Bereich (10) ein elastischer Zwischenbereich (6) aus weichem und flexiblem Polymermaterial angeordnet ist
- 50 4. Verbundprofil nach einem der Ansprüche 1 bis 3, wobei mindestens ein Wärmekompensationsabstandhalter (3,4) mindestens auf einem Teil seiner Länge geschlossene Luftkammern aufweist
5. Verbundprofil nach einem der Ansprüche 1 bis 4, wobei mindestens ein Wärmekompensationsabstandhalter (3, 4) auf einer oder beiden Seiten zusätzliche Vorsprünge zum Anbringen von Schienen oder Kappen (11) aufweist
- 55 6. Verbundprofil nach einem der Ansprüche 1 bis 5, wobei das harte Polymermaterial ausgewählt ist aus Polyamid (PA), Acrylnitril-Butadien-Styrol (ABS)-Terpolymer und Polyethylenterephthalat (PET).

7. Verbundprofil nach einem der Ansprüche 1 bis 6, wobei das weiche und flexible Polymermaterial ein thermoplastisches Elastomer ist

5 **Revendications**

1. Profil composite à isolation thermique, notamment pour fenêtres, portes, façades et similaires, comprenant au moins un profil extérieur en aluminium (1) et au moins un profil intérieur en aluminium (2), reliés entre eux au moyen d'au moins deux entretoises de compensation thermique (3, 4) disposées essentiellement parallèlement l'une à l'autre, chaque entretoise (3, 4) étant constituée de:

(a) au moins deux matériaux de dureté différente et a la forme d'une bande allongée comprenant deux régions de bord distal (5) le long de ses deux bords plus longs, les régions de bord distal (5) étant adaptées pour être serties dans les profilés d'aluminium externes et internes (1, 2) et étant constituées d'un matériau polymère dur; et  
 (b) au moins une région élastique intermédiaire (6) en matériau polymère souple et élastique étant prévue entre les régions de bord (5),

**caractérisé en ce qu'**au moins deux ailettes en aluminium (7) sont disposées parallèlement l'une à l'autre entre les entretoises (3, 4) et les recouvrent ensemble,

chaque ailette en aluminium (7) a la forme d'une bande allongée comprenant des régions de bord distales (8) le long de ses deux bords plus longs, lesdites régions de bord distales (8) étant encliquetées et/ou glissées dans des rainures correspondantes (9) formées sur les côtés de la entretoises de compensation thermique (3, 4) se faisant face,

où chaque région de bord distal (8) de chaque ailette en aluminium (7) forme un joint élastique avec la rainure correspondante (9).

2. Profil composite selon la revendication 1, dans lequel au moins une entretoise de compensation thermique (3, 4) est constituée de trois régions s'étendant longitudinalement sur toute sa longueur, les deux régions de bord distal (5) étant en un matériau polymère dur, et une région élastique intermédiaire (6) située entre ces régions de bord distal (5) est constituée d'un matériau polymère souple et élastique.

3. Profil composite selon la revendication 1 ou 2, dans lequel au moins l'un des deux entretoises de compensation thermique (3, 4) est constitué de cinq régions s'étendant longitudinalement sur toute sa longueur, les deux régions de bord distal (5) et une région centrale (10) étant constituées d'un matériau polymère dur, et entre chacune des régions de bord distal (5) et la région centrale (10) il y a une région élastique intermédiaire (6) faite d'un matériau polymère doux et flexible.

4. Profil composite selon l'une quelconque des revendications 1 à 3, dans lequel au moins une entretoise de compensation thermique (3, 4) comporte des chambres à air fermées au moins sur une partie de sa longueur.

5. Profil composite selon l'une quelconque des revendications 1 à 4, dans lequel au moins une entretoise de compensation thermique (3, 4) présente sur un ou deux côtés des saillies supplémentaires pour la fixation de rails ou de capuchons (11).

6. Profil composite selon l'une quelconque des revendications 1 à 5, dans lequel le matériau polymère dur est choisi parmi le polyamide (PA), le terpolymère acrylonitrile-butadiène-styrène (ABS) et le poly(téréphtalate d'éthylène) (PET).

7. Profil composite selon l'une quelconque des revendications 1 à 6, dans lequel le matériau polymère souple et flexible est un élastomère thermoplastique.

FIG. 1

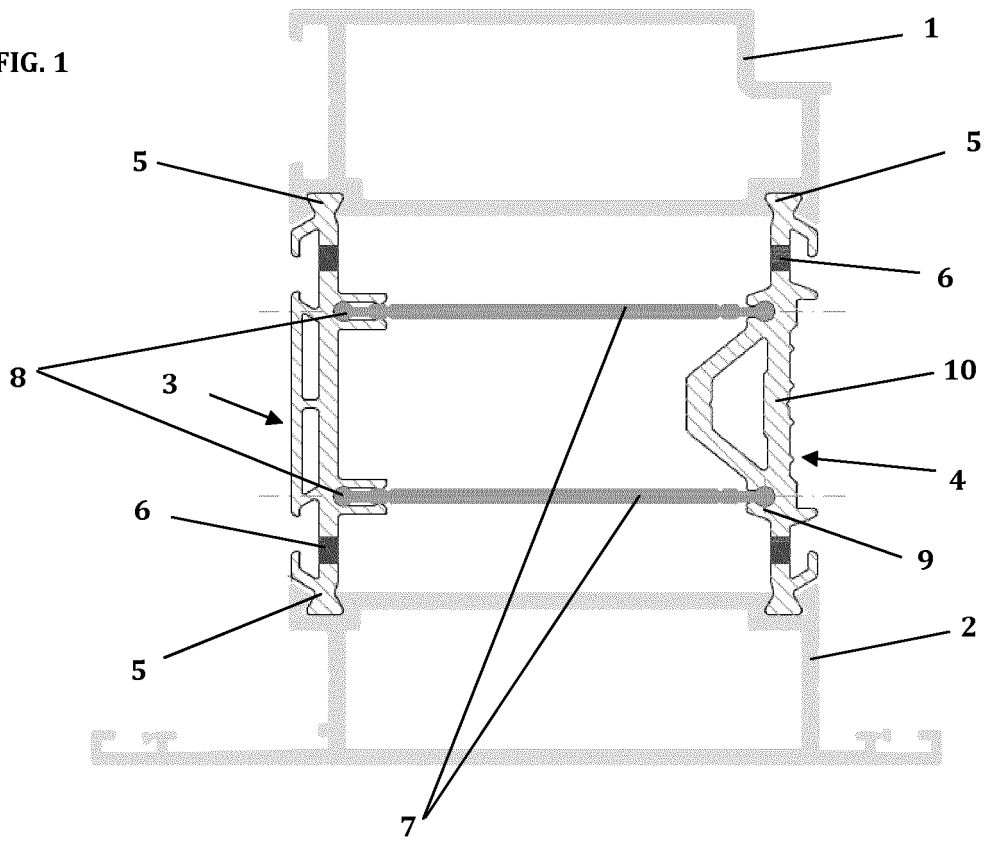
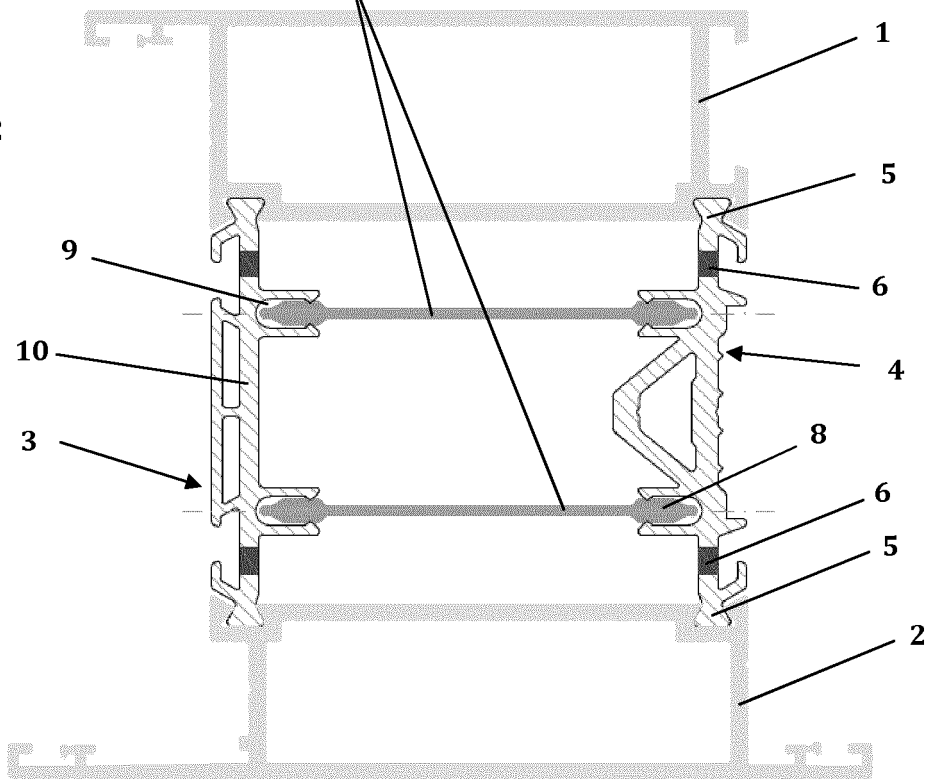

FIG. 2



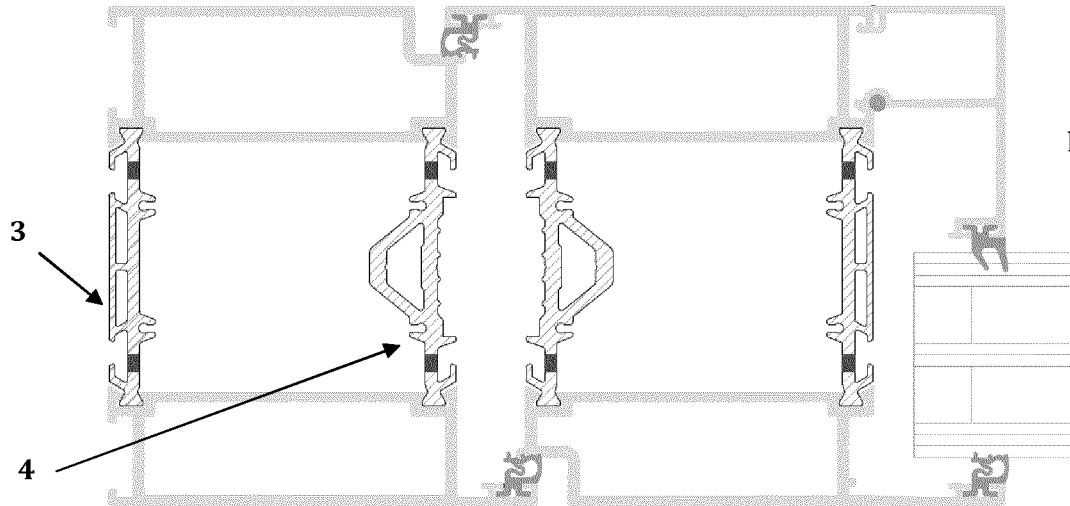

FIG. 3a

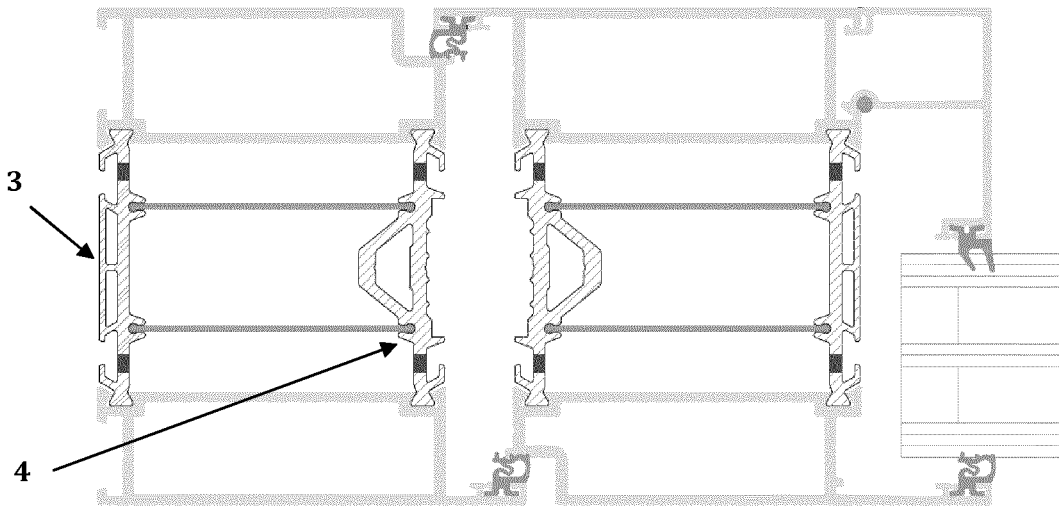

FIG. 3b

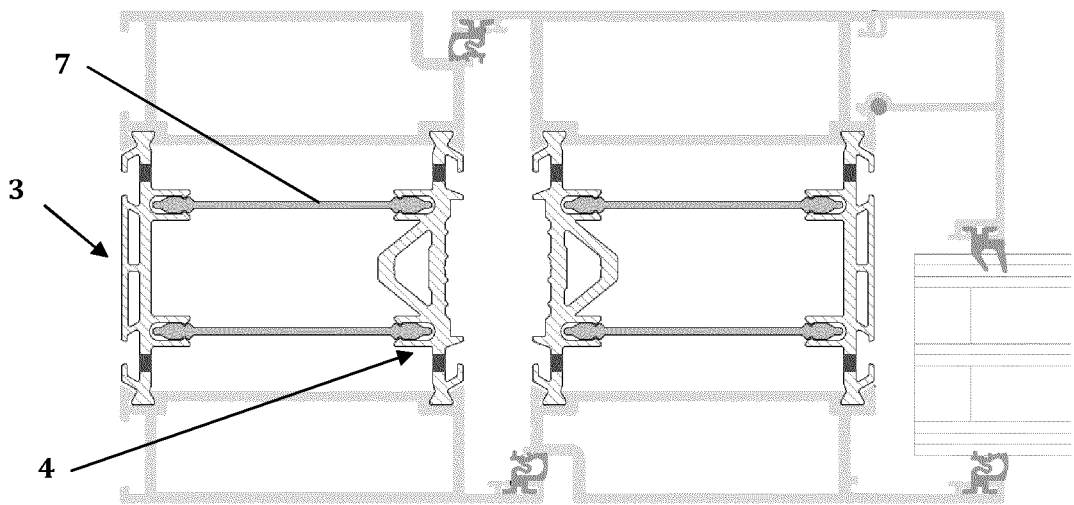
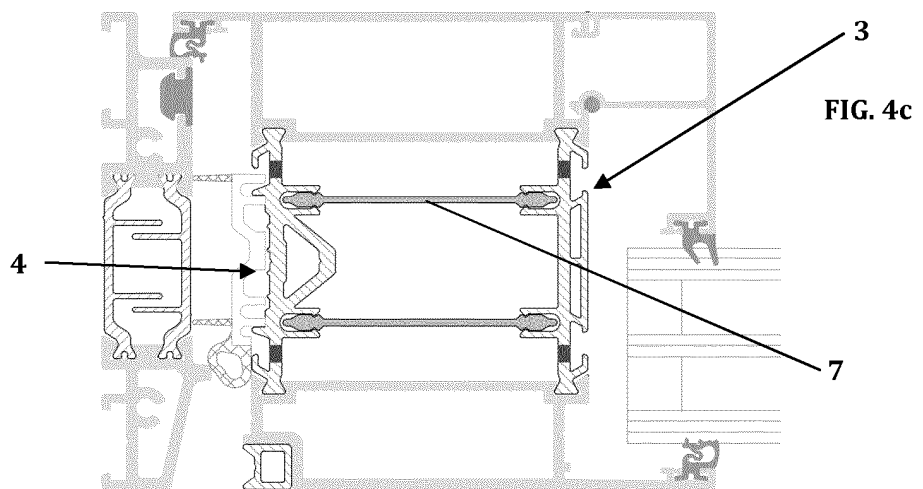
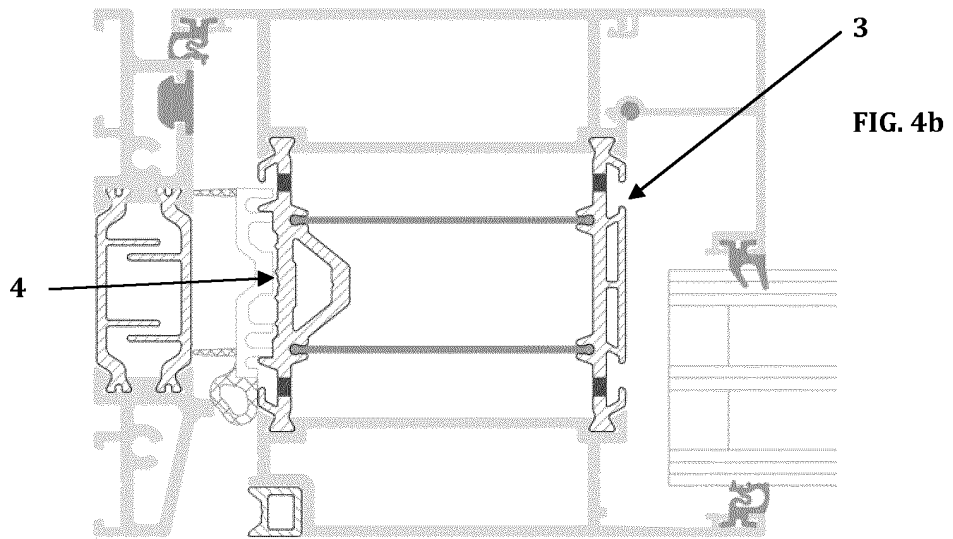
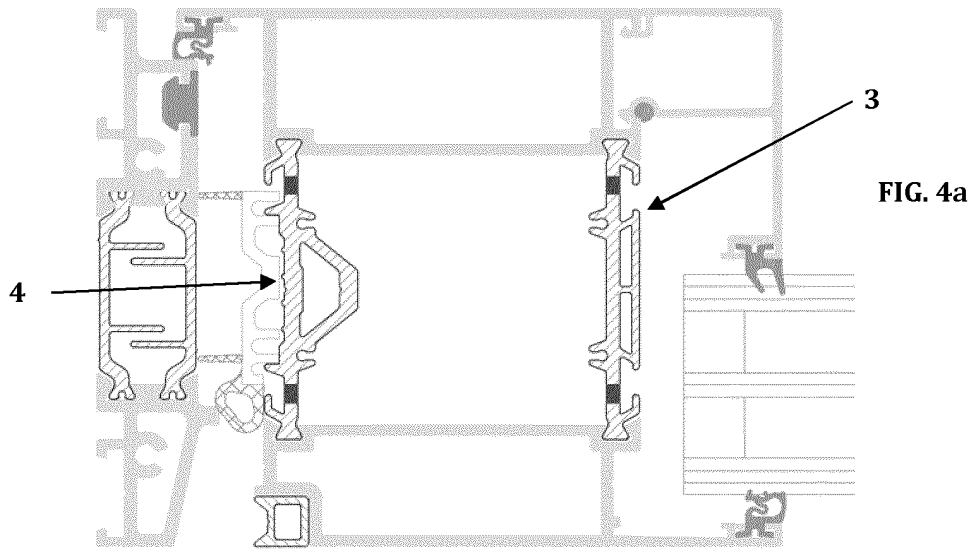

FIG. 3c



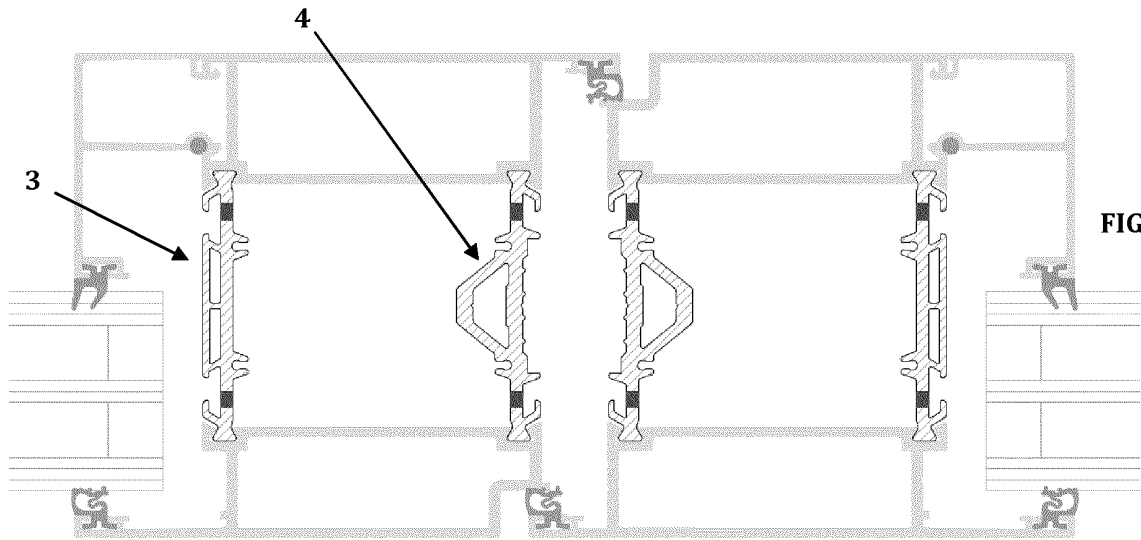

FIG. 5a

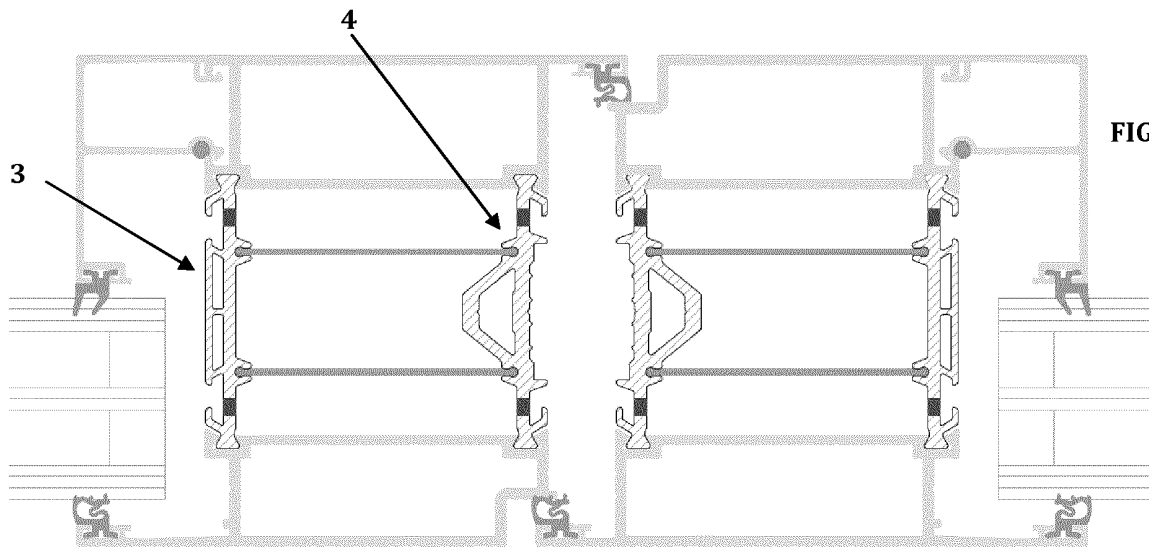

FIG. 5b

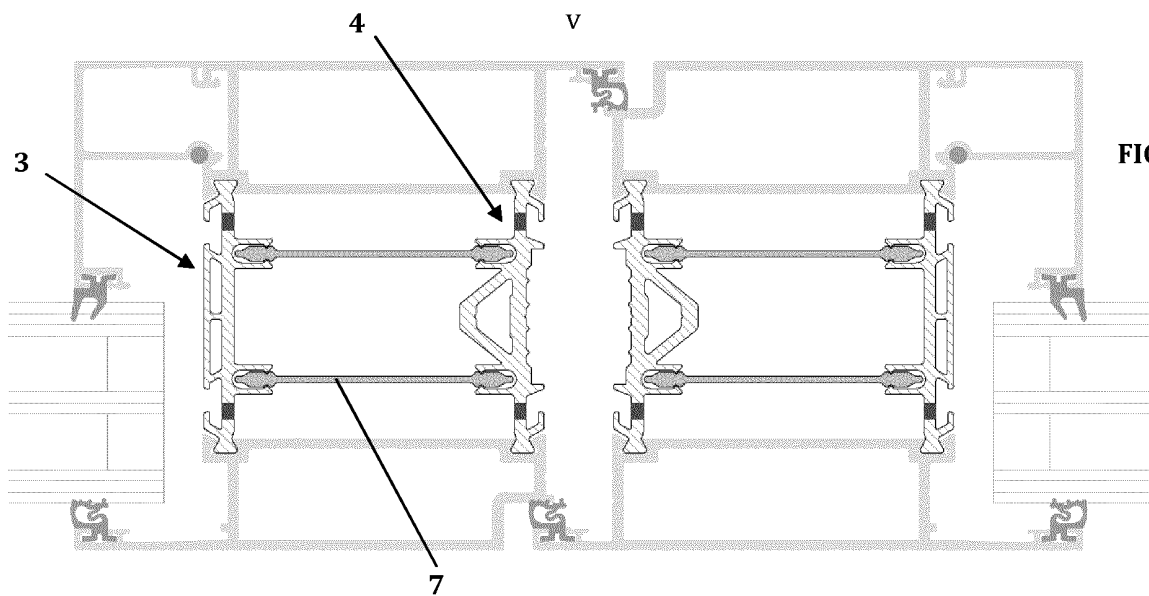
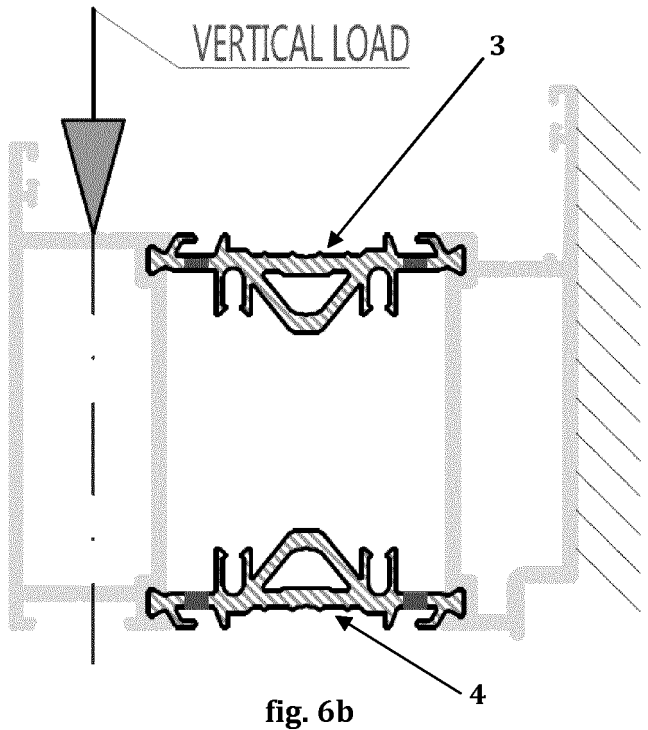
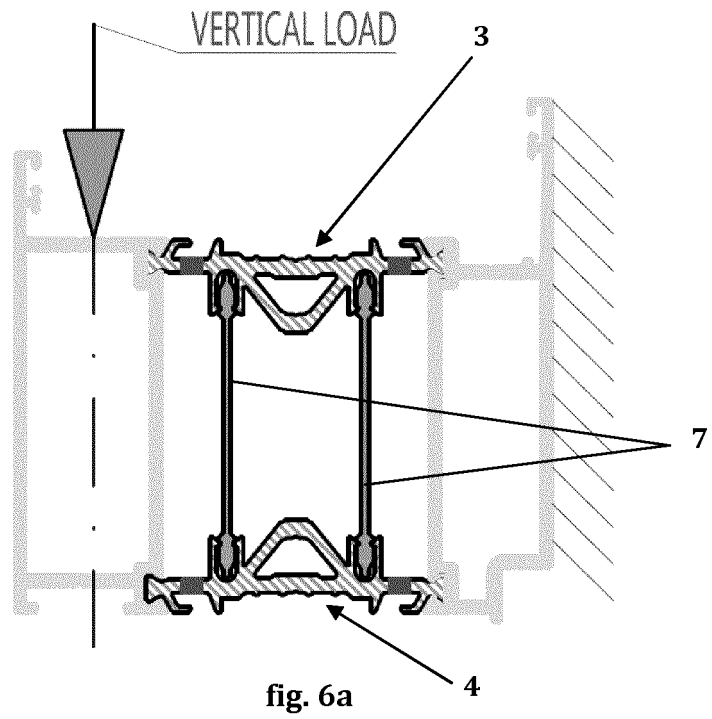

FIG. 5c



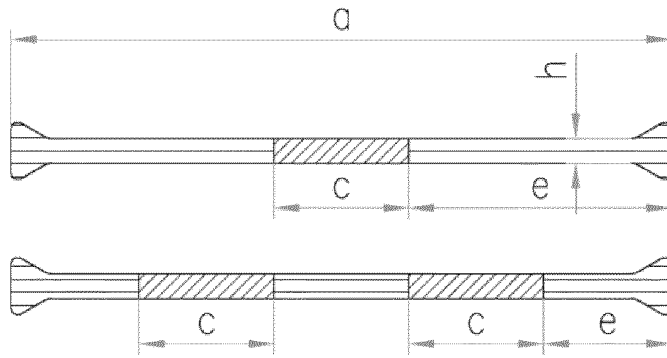

FIG. 7

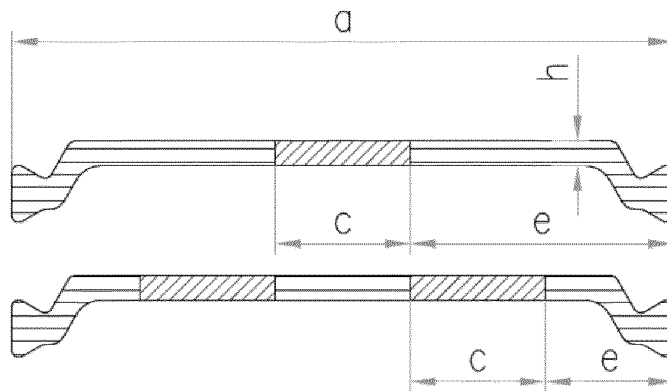

FIG. 8

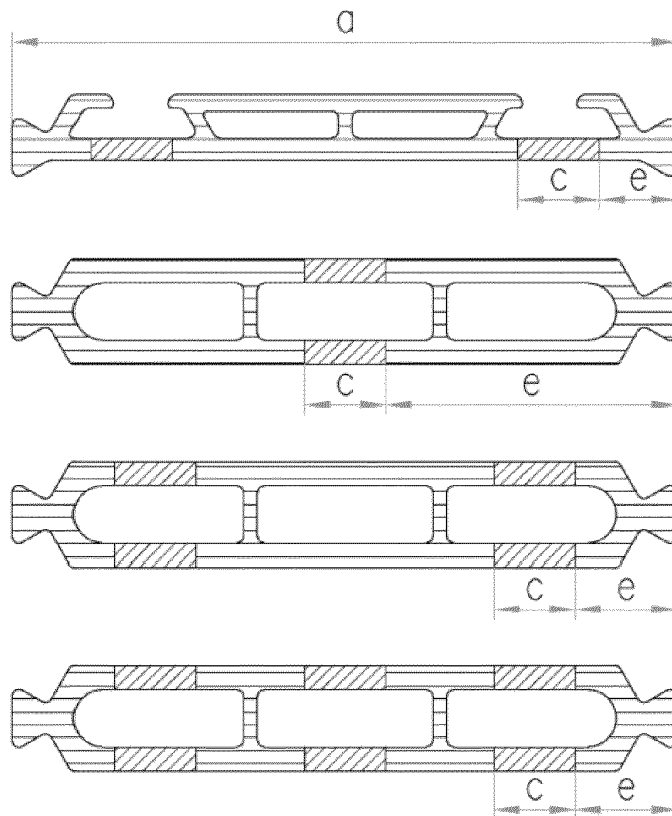

FIG. 9

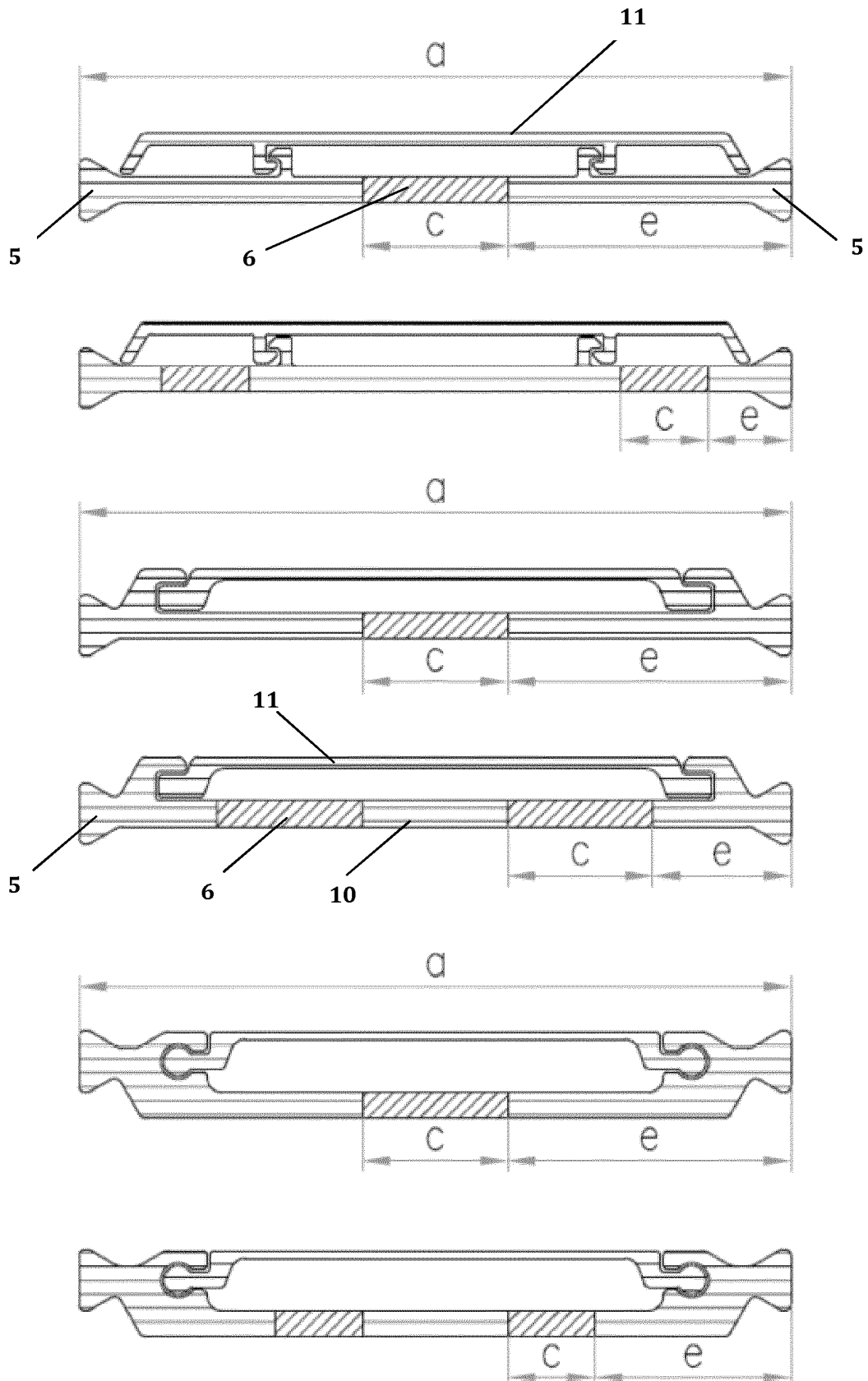

FIG. 10

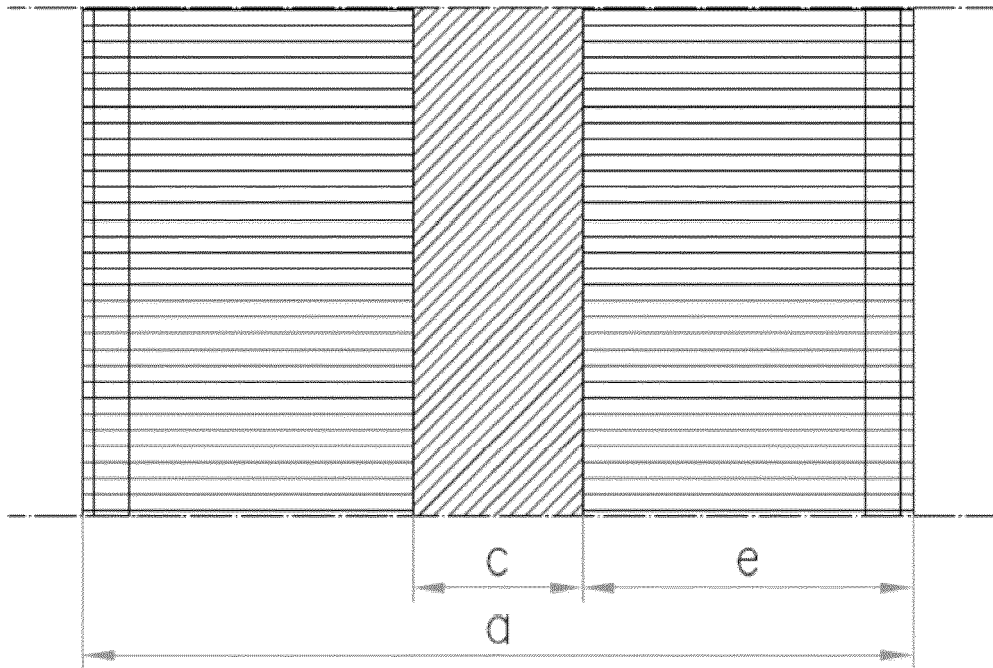

FIG. 11

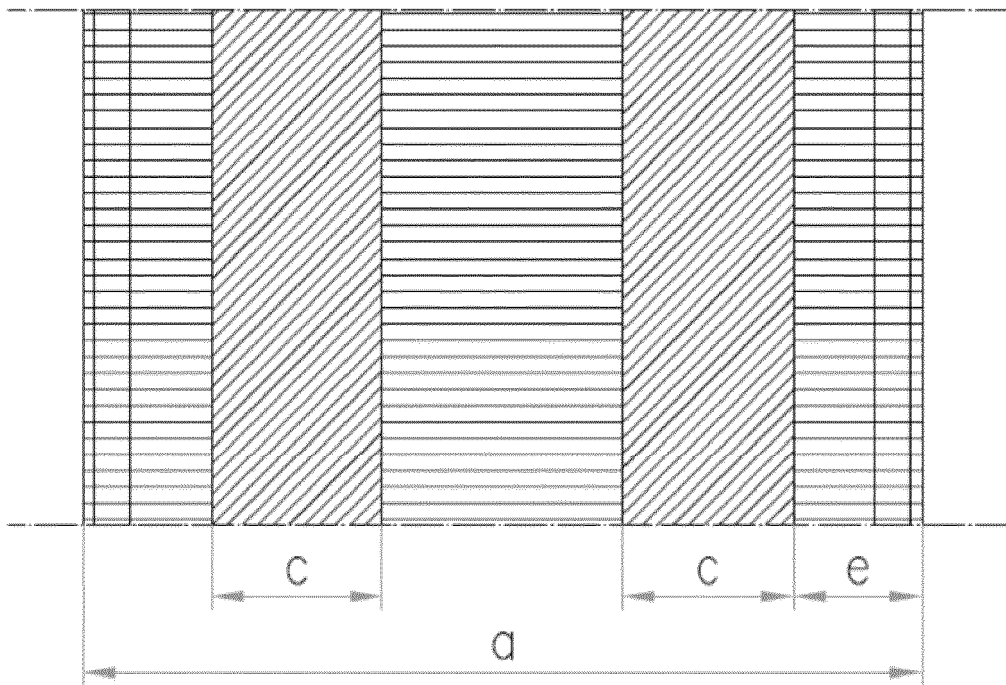

FIG. 12

**REFERENCES CITED IN THE DESCRIPTION**

*This list of references cited by the applicant is for the reader's convenience only. It does not form part of the European patent document. Even though great care has been taken in compiling the references, errors or omissions cannot be excluded and the EPO disclaims all liability in this regard.*

**Patent documents cited in the description**

- WO 388324 A [0004]
- PL 66696 Y1 [0004]
- PL 66697 Y1 [0004]
- US 7913470 B [0008]
- US 20100115850 A [0008]
- EP 1002924 A2 [0009] [0010] [0011]
- DE 102004038868 A1 [0009]
- DE 102004038868 [0011]