

(19) World Intellectual Property Organization  
International Bureau



(43) International Publication Date  
29 October 2009 (29.10.2009)

(10) International Publication Number  
**WO 2009/132318 A1**

- (51) **International Patent Classification:**  
C08L 101/16 (2006.01) C08L 97/02 (2006.01)
- (21) **International Application Number:**  
PCT/US2009/041731
- (22) **International Filing Date:**  
24 April 2009 (24.04.2009)
- (25) **Filing Language:** English
- (26) **Publication Language:** English
- (30) **Priority Data:**  
61/048,084 25 April 2008 (25.04.2008) US  
61/163,431 25 March 2009 (25.03.2009) US
- (71) **Applicant (for all designated States except US):**  
**SEANET DEVELOPMENT, INC.** [US/US]; 10020  
Main Street, Suite 209, Bellevue, WA 98004 (US).
- (72) **Inventors; and**
- (75) **Inventors/Applicants (for US only):** **PIERCE, David**  
[US/US]; 20118 Se 138th Street, Renton, WA 98059  
(US). **URQUHART, Edward** [US/US]; 1632 92nd Av-  
enue Ne, Clyde Hill, WA 98004 (US).
- (74) **Agents:** **WOOLSTON, Robert, G.** et al.; Perkins Coie  
Llp, P.o. Box 1247, Seattle, WA 98111-1247 (US).

(81) **Designated States (unless otherwise indicated, for every kind of national protection available):** AE, AG, AL, AM, AO, AT, AU, AZ, BA, BB, BG, BH, BR, BW, BY, BZ, CA, CH, CN, CO, CR, CU, CZ, DE, DK, DM, DO, DZ, EC, EE, EG, ES, FI, GB, GD, GE, GH, GM, GT, HN, HR, HU, ID, IL, IN, IS, JP, KE, KG, KM, KN, KP, KR, KZ, LA, LC, LK, LR, LS, LT, LU, LY, MA, MD, ME, MG, MK, MN, MW, MX, MY, MZ, NA, NG, NI, NO, NZ, OM, PG, PH, PL, PT, RO, RS, RU, SC, SD, SE, SG, SK, SL, SM, ST, SV, SY, TJ, TM, TN, TR, TT, TZ, UA, UG, US, UZ, VC, VN, ZA, ZM, ZW.

(84) **Designated States (unless otherwise indicated, for every kind of regional protection available):** ARIPO (BW, GH, GM, KE, LS, MW, MZ, NA, SD, SL, SZ, TZ, UG, ZM, ZW), Eurasian (AM, AZ, BY, KG, KZ, MD, RU, TJ, TM), European (AT, BE, BG, CH, CY, CZ, DE, DK, EE, ES, FI, FR, GB, GR, HR, HU, IE, IS, IT, LT, LU, LV, MC, MK, MT, NL, NO, PL, PT, RO, SE, SI, SK, TR), OAPI (BF, BJ, CF, CG, CI, CM, GA, GN, GQ, GW, ML, MR, NE, SN, TD, TG).

**Published:**

— with international search report (Art. 21(3))

(54) **Title:** MOLDED, RECYCLABLE, COMPOSTABLE CELLULOSE FIBER LID ASSEMBLY FOR A CONTAINER

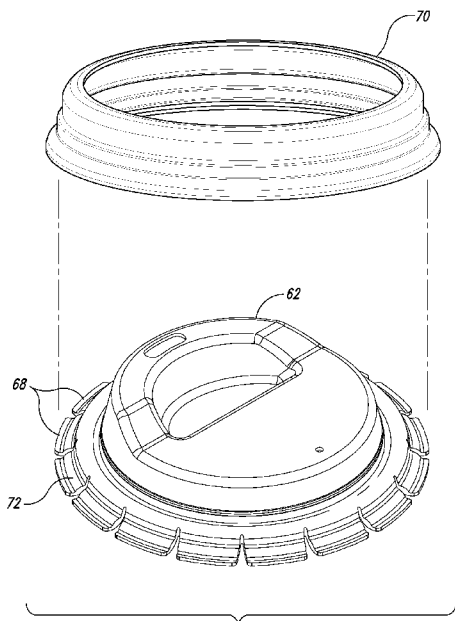


Fig. 7

(57) **Abstract:** Lid assemblies, containers, and methods of producing them are disclosed herein. A lid assembly, comprising a dome portion, a rim-receiving portion, and a compression ring are configured to attach to a container and provide a seal between the lid assembly and the container. The lid assembly is made of a reusable, recyclable, and compostable material, such as molded paper, pulp, natural cellulose fibers cellulose fiber, tapioca, wood, agricultural recycled crop materials, plastics (PLA), clay, metals, petro plastics, silicone, PVC s, and PET styrene.

WO 2009/132318 A1

MOLDED, RECYCLABLE, COMPOSTABLE CELLULOSE FIBER  
LID ASSEMBLY FOR A CONTAINER

CROSS REFERENCE TO RELATED APPLICATIONS

**[0001]** This application is an international patent application that claims the benefit of and priority to U.S. Provisional Patent Application No. 61/163,431, titled MOLDED, RECYCLABLE CELLULOSE FIBER LID ASSEMBLY FOR A CONTAINER, filed March 29, 2009, and U.S. Provisional patent application No. 61/048,084, titled TWO-PIECE INTERNALLY FITTED LID ASSEMBLY WITH BAFFLE, filed April 25, 2008, both of which are incorporated herein in their entireties by reference thereto.

TECHNICAL FIELD

**[0002]** The present invention is related to containment systems, and more particularly to lids and covers for use with one or more containers.

BACKGROUND

**[0003]** Take out disposable beverage, food, and other containers have a manifest need for lids or closures which prevent the contents of the container from spilling out of the opening used for filling and drinking during normal movement. These lids or closures also provide varying degrees of insulation from temperature change.

**[0004]** Conventional methods to achieve spill protection and insulation use plastic thermoformed lids which snap over the top and exterior of the beverage container, taking advantage pliability and memory of the plastic lid and the paper cup to achieve a snap-lock throughout the circumference of the lip of the beverage container opening. Another variation of conventional lids is to create an

embossment in the internal wall of the container below the lip of the container which runs the circumference of the container or is in place at parts of the circumference which when the lid or closure is fitted internally to the container have a matching embossment which snap seals using a similar principle to the external snap lip mentioned above. Other conventional means to secure a lid or closure to the beverage container include flexible gaskets and threaded screw closure mechanisms.

**[0005]** Plastic materials, however, are not biodegradable or compostable, so the convenience of these lids is offset by their poor environmental impact. Plastic materials are chosen over molded paper, pulp, or other natural cellulose fibers because such compostable materials are substantially not elastic or flexible enough to be produced through molded or formed paper machinery in the same manner in which plastic lids are made. Molded paper, pulp, or other natural cellulose fibers, however, are not only easily recyclable, but are compostable as well. This generally means that the materials can break down into material at a rate comparable to paper, and into a material that can support plant life. However, despite the attractive environmental characteristics of compostable materials, conventional methods cannot produce a convenient lid from these materials, in part because of the lack of memory and flexibility.

#### SUMMARY

**[0006]** The present disclosure is directed to a molded recyclable, disposable, and/or compostable cellulose fiber lid assembly that overcomes drawbacks experienced in the prior art. One aspect provides an internally fitted lid assembly with a baffle and a separable dome that overcomes drawbacks experienced in the prior art. The lid assembly can be made of recyclable and/or compostable material. A generally accepted definition of compostable is a material that is able to break down into carbon dioxide, water and biomass at the same rate as paper. Compostable material generally looks like compost, does not produce toxic material

and is generally able to support plant life. Some aspects of the present disclosure are directed to a lid assembly made from a compostable material, including a dome portion configured to at least substantially cover an opening of a container. The dome portion includes a top surface; a sidewall extending downwardly from the top surface; and a flange extending radially outwardly from the sidewall. The lid assembly also includes a baffle member comprising: a rim receiving portion configured to receive a rim of the opening of the container; a baffle sidewall extending downwardly and radially inwardly from the rim-receiving member; and a baffle extending radially inwardly from the baffle sidewall. The dome portion is configured to fit inside the baffle member with the flange the baffle sidewall at a portion above the baffle, such that when the dome portion is pressed down onto the baffle member, the flange frictionally engages the baffle member and presses the baffle sidewall against a surface of the container.

**[0007]** In other aspects, the present disclosure is directed to a two-piece lid assembly. The two-piece lid assembly includes a dome portion comprising: a top portion having an upper surface; a rim-receiving portion connected to the top portion, the rim-receiving portion extending around a perimeter of the dome portion; and a plurality of tabs spaced circumferentially at a perimeter of the dome portion and extending downwardly and radially outwardly from the rim-receiving portion. The two-piece lid assembly also includes a compression ring configured to fit over the rim-receiving portion and at least a portion of the tabs, the compression ring being sized slightly smaller than the dimension of the tabs such that when the compression ring is placed over the dome portion the tabs are pressed inwardly to engage a surface of a container to secure the lid assembly to a lip defining an opening in the container. The dome portion and the compression ring are made of a compostable material.

**[0008]** Another embodiment provides a method of constructing a compression ring for a lid assembly and an insulating sleeve. The method includes forming a frusto-conical shaped structure from compostable paper or cellulose fibers, the

structure having a first end and a second end, the first and second ends having a first and second diameter, wherein the first diameter is larger than the second diameter such that an angle of the structure between the first and second ends defines a draft-angle. The method continues by forming the first end into a compression ring including a plurality of ridges and contours to match a dome portion of a lid assembly. The method continues by forming the second end into a frusto-conical sleeve shape with substantially straight sidewalls, wherein the draft angle corresponds to a draft angle of at least one cup size. The method also includes severing the structure between the compression ring and the second end to produce a compression ring and an insulating sleeve.

**[0009]** Still other embodiments of the present disclosure are drawn to a container made of a compostable material, comprising a container having a body portion and a rim; a hinge connected to the container; and a lid assembly. The lid assembly includes a dome portion; a rim-receiving portion connected to the dome portion and extending downwardly and radially outwardly from the dome portion, the rim-receiving portion being configured to engage with the rim of the container; and a plurality of tabs extending downwardly and outwardly from the rim-receiving portion, the tabs being spaced circumferentially around the rim-receiving portion. The lid assembly also includes a compression ring sized to be placed over the rim-receiving portion and the plurality of tabs, such that the compression ring presses the tabs downwardly and inwardly over the rim to create a seal between the lid assembly and the container when the lid assembly is in a closed position.

#### BRIEF DESCRIPTION OF THE DRAWINGS

**[0010]** In the drawings, identical reference numbers identify similar elements or features. The sizes and relative positions of elements in the drawings are not necessarily drawn to scale. For example, the shapes of various elements and angles are not drawn to scale, and some of these elements are arbitrarily enlarged and positioned to improve drawing legibility. Further, the particular shapes of the

elements as drawn are not intended to convey any information regarding the actual shape of the particular elements, and have been solely selected for ease of recognition in the drawings. Understanding that these drawings depict only typical embodiments of the disclosure and are not therefore to be considered to be limiting of its scope, the disclosure will be described and explained with additional specificity and detail through the use of the accompanying drawings.

**[0011]** Figure 1 is an isometric view of a lid assembly installed on a cup in accordance with an embodiment of the present disclosure.

**[0012]** Figure 2 is an exploded isometric view of the cup and lid assembly of Figure 1.

**[0013]** Figure 3 is an exploded isometric view of the cup and lid assembly of Figure.

**[0014]** Figure 4 is an exploded cross-sectional view of the cup and lid assembly of Figure 1.

**[0015]** Figure 5 is a cross-sectional view of the cup and lid assembly of Figure 1.

**[0016]** Figure 6 is an isometric view of a lid assembly comprising a dome portion and a compression ring.

**[0017]** Figure 7 is an isometric view of a lid assembly comprising a dome portion and a compression ring.

**[0018]** Figure 8 is an enlarged cross-sectional view of a flange on the dome portion.

**[0019]** Figure 9 is a cross-sectional view of a cup and lid assembly in assembled position, the lid assembly comprising a dome portion and a compression ring.

**[0020]** Figure 10 is a cross-sectional view of a compression ring with a shoulder that extends radially inwardly.

**[0021]** Figure 11 is a cross-sectional view of a compression ring with a shoulder that extends radially outwardly.

**[0022]** Figure 12 is an isometric view of a compression ring with locking portions.

**[0023]** Figure 13 is a cross-sectional view of a compression ring with locking portions.

**[0024]** Figure 14 is an isometric view of the underside of a dome portion of a lid assembly.

**[0025]** Figure 15 is a cross-sectional view of a dome portion and a compression ring showing the compression ring in three different positions relative to the dome portion.

**[0026]** Figures 16A and 16B are a top plan view and a cross-sectional view, respectively, of a lid assembly where a dome portion and a compression ring are connected by a connecting strip.

**[0027]** Figure 17 is a cross-sectional view of a compression ring manufactured integrally with an insulating sleeve.

**[0028]** Figures 18A, 18B, and 18C are cross-sectional views of a lid assembly comprising a dome portion and a shrinkable compression ring.

**[0029]** Figure 19 is an isometric view of a container with a hinge and a lid assembly.

**[0030]** Figure 20 is a side view of a container with a hinge and a lid assembly.

**[0031]** Figure 21 is a rear view of a container with a hinge and a lid assembly.

**[0032]** Figure 22 is an isometric view of a container with a hinge and a lid assembly.

[0033] Figure 23 is a schematic view of several shapes of container and lid assembly.

[0034] Figure 24 is an isometric view of a one-piece lid assembly with a dimpled periphery.

[0035] Figure 25 is an isometric view of a compression ring.

[0036] From the foregoing, it will be appreciated that specific embodiments of the invention have been described herein for purposes of illustration, but that various modifications may be made without deviating from the spirit and scope of the invention. Accordingly, the invention is not limited except as by the appended claims.

#### DESCRIPTION

[0037] The present disclosure describes embodiments of a lid assembly for use with a container. Several specific details of the disclosure are set forth in the following description and in Figures 1–23 to provide a thorough understanding of certain embodiments of the disclosure. One skilled in the art, however, will understand that the present disclosure may have additional embodiments, and that other embodiments of the disclosure may be practiced without several of the specific features described below.

[0038] Figure 1 shows a cup 12 with a lid assembly 14 in place atop the cup 12. The cup 12 of the illustrated embodiment is a disposable cup configured to contain hot beverages, i.e. coffee, tea, cocoa, hot water, cider, or other hot beverage. The cup 12 could also be used with other contents, including cold beverages. The cup 12 can be disposable, recyclable, compostable, and/or re-usable. The cup 12 and other components can be made of paper, pulp, plastic or other conventional materials. The lid assembly 14 comprises a dome portion 16 that protrudes upward from the top of the cup 12. The dome portion 16 contains a sip hole 18 and an air hole 20 to facilitate drinking the beverage from the cup 12. Figure 2 is an exploded

view of the lid assembly 14. The cup 12 has sidewalls 22 with an upper edge 24 configured with an upper lip 26 that defines an opening 28 through which the beverage can pass. In the illustrated embodiment, the upper lip 26 is rolled, although other lip configurations are possible without departing from the scope of the present disclosure. The sidewalls 22 of the cup have an inner surface 30 around the opening 28, and the side walls 22 are oriented at a select angle or draft. While the illustrated container is a cup 12 with a round shape and opening, other containers having other shapes such as an oval, ellipse, rectangle, polygonal, or other shape, can have similar features to the features described herein with respect to the 12 cup and opening.

**[0039]** The lid assembly 14 has an internally fitted baffle portion 32 removeably insertable into the opening 28 and a dome portion 34 removeably positionable on the baffle portion 32 to provide a closure over the cup's opening. The baffle portion 32 has a top lip 36 that fits over the lip 26 of the cup 12, an side wall 38 connected to the lip 36, and a generally horizontal baffle member 40 projecting radially inward from the side wall 38. The baffle's sidewall 38 has an outer diameter slightly smaller than the inner diameter of the cup's 12 sidewalls 22 adjacent to the cup's opening 28. The baffle's sidewalls 38 also have a draft angle that substantially matches the draft angle of the cup's 12 sidewalls 22. Accordingly, the baffle's sidewalls 38 fit within and substantially against or immediately adjacent to the sidewalls 22 of the cup 12 within the opening 28, and the baffle's top lip 36 is positioned over the lip 26 of the cup 12.

**[0040]** The baffle member 40 projects radially inward a short distance to form a barrier that helps block the beverage from sloshing or spraying out the cup's opening 28, such as when a user is carrying or jostling a beverage in the cup 12. The baffle member 40, however, does not substantially interfere with drinking the beverage in a normal way by tipping the cup 12 so the beverage flows over the baffle member 40 and into the user's mouth.

**[0041]** Figure 3 is another exploded illustration of the cup assembly 14. The baffle member 40 defines a flat shoulder 42 on which the dome portion 16 can be positioned. The dome member 16 has sidewalls 44 that fit within the inner diameter of the baffle's side wall 38. At the base of the dome portion 16 is a flange 46 that securely engages the baffle's side wall 38 to provide a seal and frictional engagement between the components to securely hold the dome portion 16 in place on the baffle member 32 when installed. The dome portion 16 also has a top portion 48 with an air hole 20, a sip hole 18, and a recess area 50 adjacent to the drinking hole to provide an area to receive the user's upper lip (or a portion of it) when the user is drinking from the cup through the dome portion 16.

**[0042]** The lid assembly 14 of the illustrated embodiment is disposable, recyclable, and environmentally sustainable. The lid assembly 14 can be made from renewable resources which are or may be recycled materials, recyclable materials, biodegradable materials, compostable materials, made from organics: i.e. cellulose fiber, tapioca, wood, agricultural recycled crop materials, plastics (PLA), etc. Or non-organics such as clay, metals, petro plastics, i.e., Silicone, PVC's, PET styrene, etc. In the molded pulp version, as an example, a smooth and pleasing surface can be added to the paper through heat and press-in-place techniques. Other surfaces and/or textures can be used in other embodiments.

**[0043]** The lid assembly is made of paper, cellulose or other applicable material, and it provides better insulation of the temperature of the contained beverage or liquid. The internal fit area of the baffle's side wall 38 against the cup 12 is many times larger in surface area than the surface engagement between a cup 12 and a conventional, plastic, externally fitted, "snap on" lid. Accordingly, the lid assembly 14 of the disclosed embodiments provides a seal that is superior in preventing leaks, spills, or heat loss. Because the lid assembly 14 is internally fitted, it adds strength to the frame and structure of the cup 12. The lid assembly 14 helps the cup 12 resist collapse (or "pop-off") which can result from weakening caused by heat and or moisture, pressure from the consumers' grip, deformation

during impact of a drop, or deformation pressure. In fact, the lid assembly 14 is configured to encourage tighter bonding more with the cup 12 and lip 26. The design of the illustrated lid assembly 14 with the intended fit uses the deformation pressure from the user's hand to facilitate the lid assembly's 14 contact, bond, and sealed engagement with the upper edge 24 and/or sidewalls 22 of the cup 12. As stated before, a cup or other container of any other shape can be used with a lid assembly 14 shaped and configured to engage the shape of the container.

**[0044]** Figure 4 is a cross-sectional view of the cup 12, and the lid assembly 14. The lid assembly 14 comprises the baffle portion 32, and the dome portion. When the baffle portion 32 and the dome portion 16 are placed on the cup 12, the lip 36 of the baffle portion 32 is configured to engage the top edge 24 of the cup 12. The baffle's side wall 38 substantially matches the draft angle of the side walls 22 of the cup 12, such that the baffle's side wall 38 engages the side walls 22 of the cup 12. Because flanges 46 of the dome portion 16 are sized marginally larger than the interior of the baffle's side wall 38, the flanges 46 press the baffle portion 32 against the side walls 22, creating a strong seal between the lid assembly 14 and the cup 12. In some embodiments, flanges 46 can be configured to deflect upward when pressed against the baffle portion 32. Various variables of the lid assembly 14 can be altered to create an appropriate seal with the cup 12. For example, the thickness, materials, and angles of components of the lid assembly 14 can be altered depending on the size of the cup 12, the materials of the cup, and the intended use of the cup (e.g., hot beverages, cold beverages, or other contents).

**[0045]** The baffle portion 32 can be used as described above with the dome portion 16 installed, or the baffle portion 32 can be installed on the cup 12 without the dome portion 16 in place. The lid assembly 14 is therefore constructed so as to improve the consumer's beverage consuming experience, at least in part because a large part of taste is accomplished through olfactory senses. The lid assembly 14 allows the nose and olfactory senses to participate in the aroma of the beverage, particularly when the dome portion 16 is not installed. The lid assembly 14 can be

served with a cup to a use with the baffle portion installed and the dome portion 16 can be provided separately if desired. The baffle portion 32 resists sloshing and acts as an overflow and spill prevention device, since the horizontal position of the baffle member 40 directs liquid back down and into cup during normal shaking and jostling. The consumer can, however, still easily tilt the cup 12 with the baffle portion 32 installed for drinking to allow liquid to pass over the baffle member 40 and into the mouth. The consumer can easily add condiments to liquid without having to remove the baffle portion 32. The baffle member 40 also allows better view and sense of liquid within the cup 12 and allows the consumer to see and feel approach of hot or cold liquid and avoid a surprise of unanticipated temperature.

**[0046]** When the dome portion 16 is affixed to the baffle for travel, driving convenience, or insulation, the baffle portion 32 continues to provide hydrostatic interference internally to prevent "gyser-ing", which is common today in conventional plastic externally fitted snap lids. The dome portion 16 can be generally frusto-conical, cylindrical, partially spherical, flat or other shape designed to match the cup 12 or other container to allow "open" or "closed" function to be built into lid assembly 14. The internally fitted aspect of the lid assembly 14 also allows for a thermally neutral zone at the dome of the container, because the dome portion 16 and the baffle portion 32 trap some insulating air between the liquid (or other contents) in the container and ambient air.

**[0047]** The baffle portion 32 and/or the dome portion 16 can be embossed or printed for instruction, identification or advertisement. In addition, the shape of either the baffle portion 32 or dome portion 16 can be adjusted for marketing or consumer experience requirements. The baffle portion 32 and/or dome portion 16 can be coated or impregnated with various desirable coating and additives to further enhance performance in sealing, strength, permeability, etc. of the lid assembly 14. In some embodiments, the dome portion 16 and the baffle portion 32 can be assembled prior to delivery.

**[0048]** Figure 5 illustrates a cross-sectional view of a cup 12 and a lid assembly 14 in place on the cup 12. The two-piece construction of the lid assembly 14, and the relative orientation of the dome portion 16 and the baffle portion 32, provides a sharp relative draft angle 52 between the dome portion 16 and the baffle portion 32 that is impossible to create in pulp molding or paper pressuring of a single piece lid, but are needed to allow consumer ease of use in drinking (keeping sip hole in closest proximity to cup edge. Accordingly, the lid assembly's 14 two-piece configuration provides a method of manufacturing these attributes into the lid assembly 14 and also result in the above listed consumer benefits. The lid assembly 14 can be manufactured through pulp molding, injection molding, thermoforming, die cutting, and/or heated die pressing. The flange 46 of the dome portion can be sized or treated during the manufacture to provide the desired flexibility or stiffness so as to engage the baffle portion 32 and deform upon insertion into baffle portion 32, while maintaining a stiffness and action of "bite" into the material of the baffle portion 32 to create seal for moisture, liquid, heat or cold.

**[0049]** Embodiments of this lid assembly 14 provide an arrangement that is easier for the consumer to use as it is substantially self "seating." The internally fitted lid assembly 14 seals a larger area of the cup opening 28 because of the matching the draft angle of wall of the baffle portion 32 with the draft angle of the beverage container. This arrangement accomplishes a number of beneficial results. For example, in one embodiment, this larger paper to paper surface area (e.g., a band 1/4" to 1" wide around the upper circumference of the cup 12) will, through close association with the contained liquid and or ambient moisture through steam or wicking, result in surface tension and thereby create a seal as a result of the pressure differential between the outside of the cup 12 because of the moisture trapped in the lid assembly 14 around the baffle's side wall 38.

**[0050]** When the baffle portion 32 is placed into the cup 12 or other container, the baffle portion 32 at times may come into contact with the liquid inside the container and some displacement of the liquid will occur. The displacement will

serve to moisten the material of the baffle portion 32 and the area of the baffle portion 32 will allow the liquid to displace internally over the baffle portion 32 without "geyser-ing", as well as allowing the barrier's side wall 38 to, in effect, "squeegee" the liquid down into the cup 12 and not upward out of and over the sides of the cup 12. This effect is further enhanced by the natural wicking and moisture absorption of paper or cellulose used in some embodiments and which can result in expansion or swelling of the paper of both container and the baffle portion 32 (internally and externally), thereby tightening the seal and increasing friction.

**[0051]** Accordingly, any moisture that wicks into the lid assembly 14 serves to enhance the seal through the properties of surface tension, pressure differential induced suction and a global expansion of the paper fibers from the slight saturation resulting from ambient atmospheric moisture from such close proximity to heat and water from hot beverage or condensation resulting from close proximity to a cold beverage.

**[0052]** This can be accomplished as a result of an additional feature of the embodiments; the use of a biodegradable and re-pulpable (in common paper recycling systems) coated paper which is very resistant on its surface to moisture while allowing the internal fibers to absorb small amounts of atmospheric ambient moisture.

**[0053]** In addition to the robust closure provided by the above characteristics; the internally fitted baffle portion 32 can also be further augmented in some embodiments by the inclusion of a flexible and malleable gasket 56 (shown in Figure 4) which can be added on to the exterior circumference of the baffle portion 32 between the upper edge 24 and the baffle's side wall 38. The manner of producing this gasket 56 and adhering it to the baffle's side wall 38 can be through printing of the gasket 56 on the side wall's 38 outer surface while the paper is flat, before it has been formed into the final baffle shape. This gasket 56 would by it's malleable

nature, serve as a further moisture barrier and would improve the seating of the lid inside the cup 12.

**[0054]** Another benefit of the internally fitted lid assembly 14 that seals and seats as described above is the radial strength improvement gained. The baffle portion's 32 relatively tall side wall 38 creates a large sealing area that greatly increases the radial strength of the container and helps prevent container compression and lid popover. In fact, the strength provided by the lid assembly 14 allows for the use thinner, more efficient cups because the lid assembly 14 provides more of the structural strength than current lids.

**[0055]** This internally fitted lid assembly 14 also augments the strength of the container when subjected to heat and moisture, a known weakness of existing beverage containers. The internally fitted lid assembly 14 is not as likely to pop off the cup 12 because the radial compression serves to make the seal more tightly.

**[0056]** Another benefit of the internally fitted lid assembly in accordance with one or more embodiments includes the chosen cellulose material that allows the exterior surface as well to be printed prior to formation as a lid, when the lid it is in flat form on standard high speed machinery with information and/or advertising.

**[0057]** Figure 6 depicts a lid assembly 60 that provides a molded, disposable, recyclable and/or compostable cellulose fiber lid assembly 60 with a dome portion 62 having a top covering portion 64 configured to extend over the top of the container, a rim-receiving portion 66 configured to substantially sealably receive and engage the rim of a container and a plurality of tabs 68 projecting radially from the rim-receiving portion 66 around the dome portion 62. A compression ring 70 fits over the dome portion 62 and locks the rim-receiving portion 66 and the tabs 68 in an engaged position so the lid assembly 60 is securely and sealably attached to the top of a container about the container's top rim.

**[0058]** Figure 7 illustrates an embodiment including a compression ring 70 that fits over the dome portion 62 and engages the tabs 68 when pushed into the fully

engaged position and pushes downwardly and radially inwardly on an outer surface 72 of the tabs 68. Shown in a higher detail cross-sectional view in Figure 8, the tabs of the illustrated embodiment have a shaped outer cam surface 74 against which the compression ring 70 presses to bend the tabs 68 and force the free ends 76 of the tabs 68 downwardly and radially inwardly to cause the tabs 68 to extend around and engage an upper portion of a rim of a container. In some embodiments, the cam surface 74 is convex. The space between the tabs 68, and the flexibility of the material, allows the tabs 68 to move radially inwardly when the compression ring 70 is installed. In some embodiments, the rim-receiving portion 66 has a general cross-sectional shape of an inverted "U" with an inner portion 67 and an outer portion 69. When the compression ring 70 is installed, the tabs 68 are pushed inwardly, causing the outer portion 69 and the inner portion 67 to move toward one another. When a container rim is present in the rim-receiving portion 66, the inner portion 67 and the outer portion 69 pinch the rim and provide a seal between the lid assembly and the container. In some embodiments, the container rim generally has a cross-sectional shape of a circle with an upper hemisphere and a lower hemisphere. The inner portion 67 and the outer portion 69 can, in some embodiments, engage the lower hemisphere of the rim to ensure a tight seal with the container rim.

**[0059]** Various components described herein can be nested with similar components. In other words, each of the compression ring 70 and the dome portion 62 of the various embodiments described herein can be nested with like units, which is beneficial for shipping and/or storage.

**[0060]** Figure 9 is a cross-sectional view of a two-piece lid assembly 80 in accordance with another embodiment of the present invention. The compression ring 82 and the tabs 68 work with the rim-receiving portion 86 to securely and sealably retain the dome portion 88 on the rim 90 of the container 92. The compression ring 82 has a lower engagement portion 94 against which the free edges 96 of the tabs 68 engage when the compressing ring 82 is snapped into its

fully installed position so as to effectively lock the compression ring 82 in position on the dome portion 88 and to lock the tabs 68 in the engagement position about the rim 90 of the container 92. In the illustrated embodiment, the tabs 82 and the compression ring 82 are configured so that when the compression ring 82 is pushed into its fully installed position on the dome portion 88 and the container 92, the user can hear and feel the compression ring 82 snap into place.

**[0061]** One advantage provided by the disclose embodiments is a superior seal between the lid assembly 80 and the container 92. This is in part because the rim-receiving portion 86 is configured to engage the rim 90 at a lower portion of the rim 90. The container 92 shown here, like many disposable containers, has a rolled rim 90 at the opening of the container. The rim 90 generally has a cross-sectional shape of a circle, that can be divided into upper and lower hemispheres. In some embodiments, the rim-receiving portion 86 is shaped and sized to extend over the upper hemisphere and a portion of the lower hemisphere, so the rim-receiving portion 86 contacts part of the lower hemisphere of the rim 90. In some configurations, the rim-receiving portion 86 can be shaped to allow a miniscule space between the rim-receiving portion 86 and the upper hemisphere of the rim 90 to ensure that when the tabs 68 are deflected inward by the compression ring 82, the rim-receiving portion 86 is pulled onto the upper hemisphere of the rim and pinches the lower hemisphere of the rim 90 from both the inside and the outside of the container 90. This engagement achieves a superior seal between the lid assembly 80 and the container 92. In one embodiment, the seal is enhanced because the inside layer or portion of the material forming the rim-receiving portion 86 (e.g., pulp, paper, or other fibrous material) can absorb moisture and swell into further conforming engagement with the rim.

**[0062]** Figures 10 and 11 are isometric and cross-sectional views of embodiments of compression rings. In the illustrated embodiment, a lower portion 102 of the compression ring 100 has a tab-engaging surface 104 and a shoulder 106 extending radially inwardly from the tab-engaging surface 104. When the

compression ring 100 is pushed onto a dome portion 88 toward the fully installed position (shown in Figure 9), the lower portion 102 of the compression ring 100 pushes downwardly on an outer surface of the dome portion 88, such as a cam surface 74 (discussed above with reference to Figure 8) so as to bend the free ends 76 of the tabs 68 downwardly and radially inwardly. The free edges 76 of the tabs 68 are configured to rest atop the shoulder 106 and against the tab-engaging surface 104 so as to effectively lock the compression ring 100 in place in the fully installed position on the dome portion.

**[0063]** When the compression ring 100 bends the free ends 76 of the tabs 68 downwardly and radially inwardly, at least a portion of the tabs 68 and/or the bottom of the rim-receiving portion 86 are effectively wrapped over a portion of the rim's lower hemisphere. Also, the compression ring 100 blocks the tabs 68 from moving radially away from the rim 90, thereby securely and sealably holding the lid assembly 80 on the container 92 and avoiding inadvertent removal of the lid assembly 80 from the container 92.

**[0064]** Turning now to Figure 11, a compression ring 110 of another embodiment of the lid assembly 80. In this embodiment, the compression ring 110 is configured with the lower portion 112 and the tab-engaging surface 114 without including the radially inwardly extending shoulder 106 shown in Figure 10. This embodiment can be formed in a single molding process. In some embodiments, formation of the shoulder 106 can require an additional formation step. Accordingly, the illustrated embodiment can be less expensive to manufacture while assuring the secure engagement of the lid assembly 80 on the container 92 during use.

**[0065]** Figures 12 and 13 are isometric and cross-sectional views of a compression ring 120 in accordance with yet another embodiment of the lid assembly 80, wherein the compression ring 120 has a plurality of locking portions 122 configured to engage the tabs 68 of the dome portion 88 to securely retain the compression ring 120 on the dome portion 88 when in the fully engaged position.

This embodiment provides an additional locking feature to hold the compression ring 120 on the dome portion 88 in the fully installed position during use, such as in an environment when the container 92 and lid assembly 80 may be subject to more aggressive handling or impacts.

**[0066]** Figure 13 shows an embodiment of the compression ring 120 in accordance with the embodiment described above with reference to Figure 10, including a tab-engaging surface 104 and a shoulder 106. The locking portion 122 includes a locking surface 126. The locking portion 122 is flexible and the locking surface 126 can be deflected radially inwardly to engage the lower hemisphere of the rim 90 of the container 92. A user can optionally press the locking portion 122 into the locked position to improve the seal between the lid assembly and the container 92, at the user's discretion.

**[0067]** Figure 14 is an isometric view of an underside of a lid assembly 130 in accordance with another embodiment. In this embodiment, the lid assembly 130 is a one-piece lid assembly with a dome portion 131 that has tabs 132 connected to adjacent tabs via a folded protrusion 134, shown in the illustrated embodiment as a V-shaped protrusion. These folded protrusions 134 are configured to flex as the tabs 132 bend downwardly and radially inwardly as the compression ring is installed. In the illustrated embodiment the folded protrusions 134 will collapse when the lid circumference is pressed in a die to reduce the circumference of the lid in a way to produce a reverse draft arrangement which will then snap under the rim of the cup rim and at the same time allow the folded protrusions 134 to use the "memory" of the "V" shape to expand and contract in an elastic manner. The folded protrusions 134 can be configured to engage a portion of the container adjacent to the rim to provide additional frictional engagement between the lid assembly and the container. The number and arrangement of the folded protrusions 134 can be adjusted according to a particular use of the lid assembly 130, and depending on the materials of the container, the dome portion 131 and the compression ring.

**[0068]** Figure 15 is a cross-sectional view of a lid assembly 140 in accordance with another embodiment wherein the compression ring 142 is configured to remain connected to the dome portion 144 when the compression ring 142 is in an uninstalled intermediate position, such as before the lid assembly 140 is attached to the container (not shown) and snapped into the fully engaged position. The dome portion 144 is shown in three different positions: an unassembled position 157 wherein the dome portion 144 and the compression ring 142 are not connected; an intermediate portion 158 in which the dome portion 144 and the compression ring 142 are coupled together; and an assembled position 159 in which the lid assembly 140 is fastened to a container.

**[0069]** In the illustrated embodiment, the compression ring 140 has a retaining portion 146 attached to the tab-engaging portion 148, and the radially inwardly extending shoulder 150 is attached to the lower part of the retaining portion 146. The retaining portion 146 is configured to receive the free ends 152 of the tabs 154 therein when the compression ring 142 is in the intermediate position 158 before the lid assembly 140 is snapped onto the container. The shoulder 150 also helps maintain the dome portion 144 and the compression ring 142 together as one unit. This allows the dome portion 144 and the compression ring 142 to be preassembled and to remain together, such as during shipping or prior at attaching to the container. Accordingly, a user, such as a customer or a coffee-barista or the like, can grab the entire pre-assembled lid assembly 140 (rather than assembling the two pieces of the lid assembly 140 when handling the lid assembly 140), place it onto a beverage cup or other container, and simply snap the compression ring 142 into its fully installed position. In this embodiment, the lid assemblies 140 can also be nested together for, as an example, storage and/or shipping.

**[0070]** Figures 16A and 16B are a top plan and a cross-sectional view, respectively, of another embodiment, wherein the dome portion 150 and the compression ring 152 are molded and connected to each other as a unitary lid assembly 153 with a thin connecting strip 154 between them. In some

embodiments, the dome portion 150 faces up and the compression ring 152 faces down, such that the connecting strip 154 can be flexed and the compression ring can be folded onto the dome portion 150. The strip 154 can be small and flexible, and even severable, frangible, or perforated. The compression ring 152 and dome portion 150 can be separated from each other during the manufacturing process or can be shipped as a unitary assembly 153. The dome portion 150 can then be separated from the compression ring 152 at the time the lid assembly 153 is snapped onto the container, such as by a customer or a barista at a coffee house. This assembly and shipping mechanism can be used with any of the embodiments disclosed herein, and is not limited to the tabbed embodiment illustrated in Figures 16A and 16B.

**[0071]** Figure 17 is a schematic views of another embodiment of the lid assembly 160 with a compression ring 162 substantially as discussed above, although during the molding process to form the compression ring an insulator sleeve 164 is simultaneously and integrally formed therewith as a unitary assembly 166. In this alternate embodiment, the unitary assembly 166, comprising compression ring 162 and the insulating sleeve 164, is molded of a pulp or other fibrous recyclable or compostable material, whereby a seamless, partially conical insulating sleeve 164 is integrally connected to a top edge of the compression ring 162. After the unitary assembly 166 is formed, the insulating sleeve 164 portion is separated from the compression ring 162, such as by a cylindrical cutting die sized and positioned to cut the assembly 166 at the union of the insulating sleeve 164 and the compression ring 162. The insulating sleeve portion 164 in one embodiment is shaped with a draft angle configured to fit over a handling portion of conventional hot beverage containers to provide an insulating sleeve portion 164 that a user can place over the container when holding the container, such as when enjoying the hot beverage. The assembly 166 can be nested with other similar assemblies 166, or each of the compression ring 162 and the insulating sleeve 164 can be nested

separately. In addition, the insulating sleeve 164 can be pressed flat, such as for shipping in bulk.

**[0072]** Figures 18A–C are cross-sectional views of a lid assembly 170 in accordance with another embodiment of the present invention. A dome portion 172 shown in Figure 18A is substantially as described above with reference to other embodiments. The dome portion 172 can be engaged with a compression ring 174, made of a recyclable, disposable shrinkable band 176 that is shrunk into engagement with the dome portion 172 of the lid assembly 170. The compression ring 174 is shown in Figure 18B before being shrunk onto the dome portion 172. The compression ring 174 can shrink under an applied heat, pressure, or other means. Figure 18C depicts the compression ring 174 and dome portion 172 assembled as a unitary lid assembly. Similar to other embodiments herein disclosed, the assembly 170 can be placed onto an open container and tabs 176 can be pressed by the compression ring 174 into engagement with the container to create a seal between the lid assembly 170 and the container. Also similar to other embodiments, these parts can be nested for ease of stacking and shipping. All parts can be assembled prior to application to make this a preassembled, one piece product.

**[0073]** Figure 19 is an isometric view of a container 200 and lid assembly 202 according to another embodiment of the present disclosure. A container 200 can be shaped and sized to meet the needs of any given application. The container 200 can be configured to contain a food product such as a hamburger, a salad, or other food product, or the container 200 can be configured for other contents or liquids. Generally, the contents will determine the dimensions and materials of the container (e.g., thicker walls can be used to carry heavier contents). In addition, the container 200 can take any shape appropriate to meet design needs or aesthetic considerations. For purposes of simplicity, a simple round container with a flat bottom is pictured in Figure 19, but it should be appreciated that the container 200 can take substantially any shape without departing from the present disclosure. A

hinge 204 connects the container 200 to the lid assembly. The hinge can be made of the same compostable materials as described above, and can be made in a unitary body as shown in Figure 19. The lid assembly can be substantially as shown and described above. The hinge 204 can be placed at a rim 206 of the container 200 and configured to allow the lid assembly 202 to be placed onto the container 200 without interfering with the sealing of the lid assembly 202 and the container 200. A compression ring (not shown) can be placed over the lid assembly to reinforce the seal, substantially as shown and described with reference to Figures 6–18 above. The embodiment shown has folded protrusions 207 between the tabs 209. The resulting structure is a strong, resilient structure that provides an excellent seal between the lid assembly 202 and the container 204, without harming the environment with plastics and other non-biodegradable materials.

**[0074]** Figures 20–22 are side, rear, and isometric views, respectively, of the container and lid assembly according to the present disclosure. Figure 22 illustrates another embodiment in which the tabs 208 are separated by a space 210, rather than a folded protrusion as shown in Figures 19–21. Although not specifically shown, other lid assembly embodiments can be used with a hinge 204 and a container 200. For example, the tabs 208 and 209 can include a cam surface similar to the cam surface described above that contacts the compression ring and causes a greater seal between the lid assembly and the container. It is to be appreciated that the lid assemblies of Figures 19–22 are shown for ease of description and simplicity, and are not meant to be limiting to the embodiments shown and described.

**[0075]** Figure 23 illustrates several shapes 210 in which the lid assembly or container of the present disclosure can be formed. These shapes are schematic top-views of a few possible shapes. It is to be appreciated that any combination of these shapes 210 or even a free-form shape is possible without departing from the present disclosure. A circular shape 212 can include a flat section 214 which can include a hinge. A hinge of a different size may require a larger or a smaller flat

portion 216. A circular shape can be implemented with no hinge. A square 218 (or rectangle), triangle 220, pentagon 222, hexagon 224, or octagon 228 are a few shapes in which the lid assembly and/or container of the present disclosure can be made. Any of the flat portions of these shapes can include a hinge. Or, an angled edge 225 can include a hinge, provided that the material has sufficient flexibility to avoid tearing when moving the hinge. For any of the polygonal shapes illustrated, rounded corners 226 can be used between straight edges. Although only a few shapes 210 are illustrated in Figure 23, the lid assembly and container can be shaped in a polygon of virtually any number.

**[0076]** Figure 24 illustrates another embodiment of a one-piece lid assembly 230. The lid assembly 230 comprises a dome portion 232 which can include a drinking hole 234, an air hole 236, and a recess 238 constructed to receive the upper lip of a consumer while drinking from the lid assembly 230. In other embodiments, the dome portion 232 can be substantially flat. The lid assembly 230 shown in Figure 24 is circular and is generally configured for use with a container, such as a cup, with a matching circular opening. However, it is to be appreciated that the embodiment described herein can take any shape, including but not limited to the shapes of Figure 23. The lid assembly 230 can include a rim-receiving portion 240 that is shaped generally to receive a rim of a container upon which the lid assembly 230 is placed. Many features of the lid assembly 230 of Figure 24 are substantially similar to features of other embodiments shown and described above, including but not limited to the generally inverted "U" shaped cross-sectional shape of the rim-receiving portion 240. The lid assembly 230 can be used with or without a compression ring and/or tabs, substantially as shown and described above. In addition, the lid assembly 230 of this embodiment can be constructed out of molded paper, pulp, or other natural cellulose fibers which are reusable, recyclable, and compostable.

**[0077]** The lid assembly 230 of the illustrated embodiment includes a plurality of circumferentially-spaced dimples 242, which can increase the seal between the

lid assembly 230 and a container. The size and placement of the dimples 242 can vary, depending on the intended use of the container and lid assembly. If, for example, more of a seal is advantageous, more dimples 242 can be used, or larger or smaller dimples 242. The dimples can appear at different vertical positions relative to the rim-receiving portion 240, as well. The dimples 242 can be molded with the lid assembly 230 during initial manufacture, or they can be pressed into the lid assembly 230 at a later stage. The lid assembly 230 with the dimples 242 can be nested with other similar lid assemblies for ease of packaging and shipping. The lid assembly 230 shown in Figure 24 can also be used with a hinged assembly, such as described above with reference to Figures 19–23.

**[0078]** Figure 25 illustrates a compression ring 250 for use with lid assemblies of the present disclosure. In selected embodiments, the compression ring 250 is configured for use with a dome portion 62, illustrated in Figures 6 and 7. The compression ring 250 can have many of the features and advantages associated with embodiments described above, and additionally comprises a plurality of columns 252 that project inwardly from the compression ring 250. The columns 252 can be wedge-shaped with a leading edge 256 and two wedge faces 258 on either side of the column 250. The compression ring 250 can include any number of columns 252. In the illustrated embodiment there are four columns 252 spaced equally around the perimeter of the compression ring 250. When placed on the dome portion 62, the columns 250 are configured to fit tightly between two of the tabs 68 such that the wedge surfaces 258 engage the tabs 68 to spread the tabs 68 apart to increase the frictional seal between the dome portion 62 and the compression ring 250, and to improve the seal between the lid assembly and a container. As described above with reference to Figures 6 and 7, the compression ring 250 is configured to press the tabs 68 inwardly to engage a rim and/or a surface of a container to tightly seal the lid assembly to the container. The columns 250 and their interaction with the tabs 68 creates further frictional engagement between the

dome portion 62 and the compression ring 250, thereby improving the seal between the lid assembly and a container.

**[0079]** Although Figure 25 depicts four equally spaced columns 250, it is to be appreciated that other embodiments can have more or fewer columns 250 spaced equally or unequally around the compression ring 250. In addition, the columns 250 can have a different shape such as square, rounded, T-shaped, or others. The slope of the wedge faces 258 can vary depending on the characteristics of the lid assembly and on the material used to make the compression ring 250 and the dome portion 62. The columns 252 can be circumferentially placed to align with tabs 68 such that all columns 252 fit between two tabs 68. As with many of the embodiments disclosed herein, the compression ring 250 can be made of a recyclable, reusable, and/or compostable material. Also, the compression ring 250, and a lid assembly including the compression ring 250, can be nested within similar components for ease of shipping and packaging.

**[0080]** From the foregoing, it will be appreciated that specific embodiments of the disclosure have been described herein for purposes of illustration, but that various modifications may be made without deviating from the disclosure. Furthermore, aspects of the disclosure described in the context of particular embodiments may be combined or eliminated in other embodiments. Further, while features and characteristics associated with certain embodiments of the disclosure have been described in the context of those embodiments, other embodiments may also exhibit such features and characteristics, and not all embodiments need necessarily exhibit such features and characteristics to fall within the scope of the disclosure. Accordingly, the disclosure is not limited, except as by the appended claims.

## CLAIMS

We claim:

1. A lid assembly for use with a container having a rim around an opening in the container, the lid assembly comprising:
  - a dome portion comprising:
    - a top portion;
    - a rim-receiving portion connected to the top portion, the rim-receiving portion extending around the dome portion; and
    - a plurality of tabs spaced circumferentially at a perimeter of the rim-receiving portion and extending radially outwardly from the rim-receiving portion;
  - a compression ring configured to fit over the rim-receiving portion and at least a portion of the tabs, the compression ring being sized such that, when the compression ring is placed over the dome portion, the tabs are pressed inwardly to engage the rim of the container to secure the lid assembly over the opening in the container;wherein the dome portion and the compression ring are made of a compostable material.
2. The lid assembly of claim 1 wherein the compostable material comprises at least one of molded paper, pulp, and natural cellulose fibers.
3. The lid assembly of claim 1 wherein the top portion of the dome portion comprises a drinking spout, and an airhole.
4. The lid assembly of claim 1 wherein the dome portion and compression ring are round, triangular, square, rectangular, or polygonal.

5. The lid assembly of claim 4 wherein the dome portion and compression ring are each a polygon with between 5 and 8 sides, inclusive.
6. The lid assembly of claim 1 wherein the rim-receiving portion has a cross-sectional shape of a generally inverted U, comprising a radially interior segment and a radially exterior segment, connected by a convex portion, wherein the convex portion is shaped to substantially match the rim of the container.
7. The lid assembly of claim 6 wherein the radially interior segment is configured to engage a portion of the container below the rim of the container when the compression ring is in place on the dome portion.
8. The lid assembly of claim 6 wherein the radially interior and radially exterior segment of the rim-receiving portion are configured to be pressed against opposing surfaces of the container when the compression ring is placed on the dome portion and moves the tabs radially inward.
9. The lid assembly of claim 8 wherein the rim of the container has a cross-sectional shape with an upper and a lower hemisphere, and the radially interior and radially exterior segments of the rim-receiving portion are configured to engage the lower hemisphere of the rolled rim on the inside and outside of the container, respectively.
10. The lid assembly of claim 1 wherein the compression ring comprises a shoulder that extends radially inwardly from a lower portion of the compression ring.
11. The lid assembly of claim 1 wherein the compression ring has an upper diameter and a lower diameter, wherein the lower diameter is larger than the upper

diameter such that the compression ring slopes downwardly and outwardly from an upper portion to a lower portion.

12. The lid assembly of claim 11 wherein the compression ring comprises a shoulder that extends radially inwardly from a lower portion of the compression ring, and wherein the dome portion has an outer diameter larger than the upper diameter of the compression ring and larger than the shoulder's radially inward projection, such that the compression ring retains the dome portion.

13. The lid assembly of claim 11 wherein the compression ring comprises a shoulder that extends radially outwardly from the lower portion of the compression ring.

14. The lid assembly of claim 1 wherein the dome portion and the compression ring are connected by a connection strip.

15. The lid assembly of claim 14 wherein the connection strip is at least one of flexible, perforated, and frangible.

16. The lid assembly of claim 14 wherein the compression ring is connected to the dome portion with the compression ring upside-down, such that the compression ring can be folded over and onto the dome portion.

17. The lid assembly of claim 1 wherein the tabs have a cam surface that engages the compression ring and is configured to move radially inwardly and engage a surface of the container to create a seal between the lid assembly and the container when the lid assembly is placed on the container and the compression ring is moved to a closed position.

18. The lid assembly of claim 17 wherein the cam surface is convex and protrudes upwardly from the tabs.
19. The lid assembly of claim 1 wherein the tabs, dome portion, and compression ring are configured to produce an audible snapping noise when the compression ring is placed over the dome portion and the tabs are pressed radially inwardly to engage the surface of the container.
20. The lid assembly of claim 1, further comprising a plurality of locking portions which extend upwardly from the compression ring, and are configured to be pressed radially inwardly to engage the rim of the container.
21. The lid assembly of claim 1 wherein the compression ring is made of a shrinkable material, the compression ring being shrunk over the dome portion during assembly.
22. The lid assembly of claim 1 wherein the dome portion and the compression ring are configured to be nested with other lid assemblies.
23. A container assembly, comprising:  
a container having a body portion and a rim;  
a hinge connected to the container; and  
a lid assembly connected to the hinge, the lid assembly being made of a compostable material, the lid assembly comprising:  
a dome portion;  
a rim-receiving portion connected to the dome portion and extending downwardly and radially outwardly from the dome portion, the rim-receiving portion being configured to engage with the rim of the container;

a plurality of tabs extending downwardly and outwardly from the rim-receiving portion, the tabs being spaced circumferentially around the rim-receiving portion; and  
a compression ring sized to be placed over the rim-receiving portion and the plurality of tabs, such that the compression ring presses the tabs downwardly and inwardly over the rim to create a seal between the lid assembly and the container when the lid assembly is in a closed position.

24. The container of claim 23 wherein the compostable material comprises at least one of molded paper, pulp, and natural cellulose fibers.

25. The container of claim 23 wherein at least some of the plurality of tabs has a cam surface configured to engage with a portion of the compression ring to cause the compression ring to press the tabs downwardly and inwardly over the rim.

26. The container of claim 25 wherein the cam surface comprises a convex cam surface that protrudes upward and outward from the tabs.

27. The container of claim 23 wherein the rim has a circular cross-sectional shape with an upper and a lower hemisphere, and wherein the rim-receiving portion is configured to engage the rolled rim at the lower hemisphere of the rolled rim at least on the inside or the outside of the container.

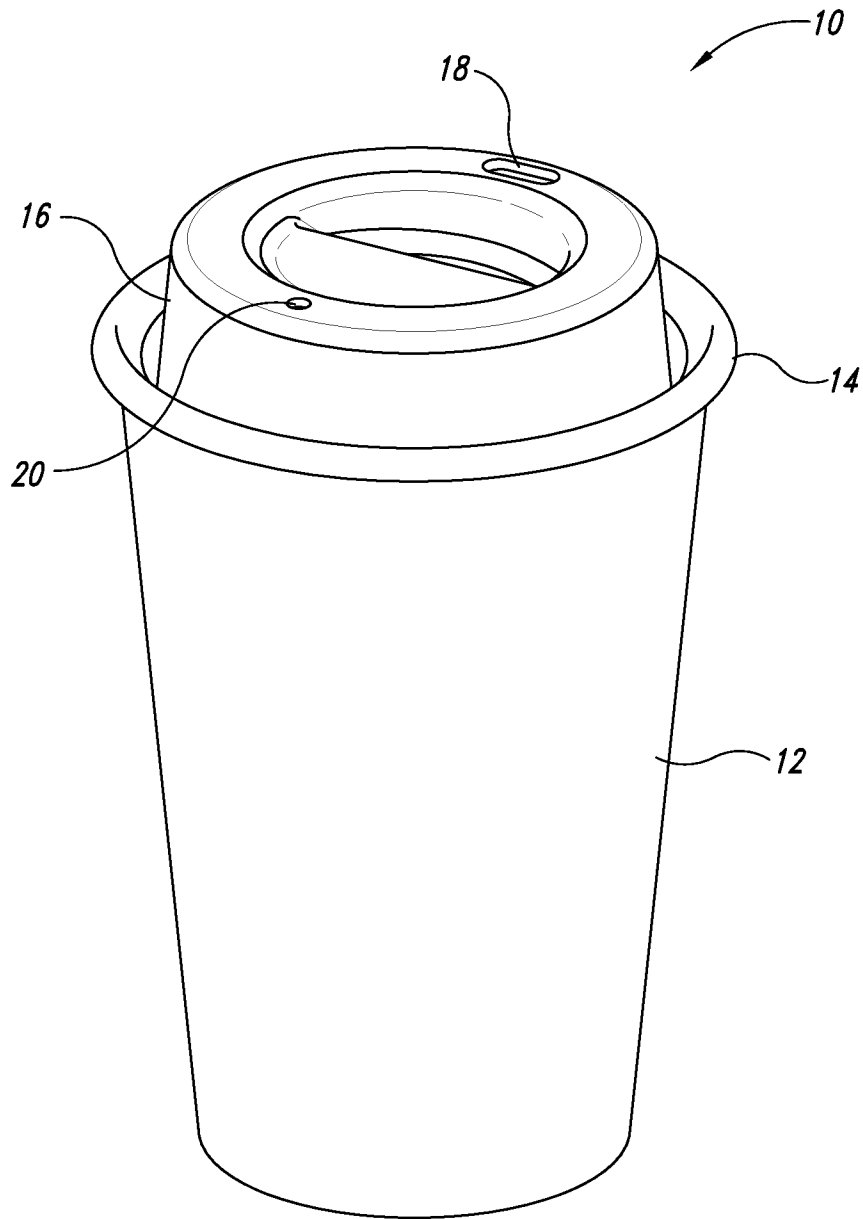
28. The container of claim 26 wherein the rim-receiving portion is further configured to engage a portion of the container below the rolled rim.

29. The container of claim 23 wherein the compression ring has an upper portion with an upper diameter, a lower portion with a lower diameter, and an

intermediate portion with an intermediate diameter, and wherein the intermediate diameter is greater than the upper diameter and the lower diameter.

30. The container of claim 29 wherein the tabs have a diameter that is smaller than the intermediate diameter of the compression ring but greater than at least one of the upper diameter or the lower diameter such that the compression ring retains the lid assembly when the lid assembly is not in the closed position.

31. The container of claim 23 wherein the lid assembly is configured to be nested with other lid assemblies.



*Fig. 1*

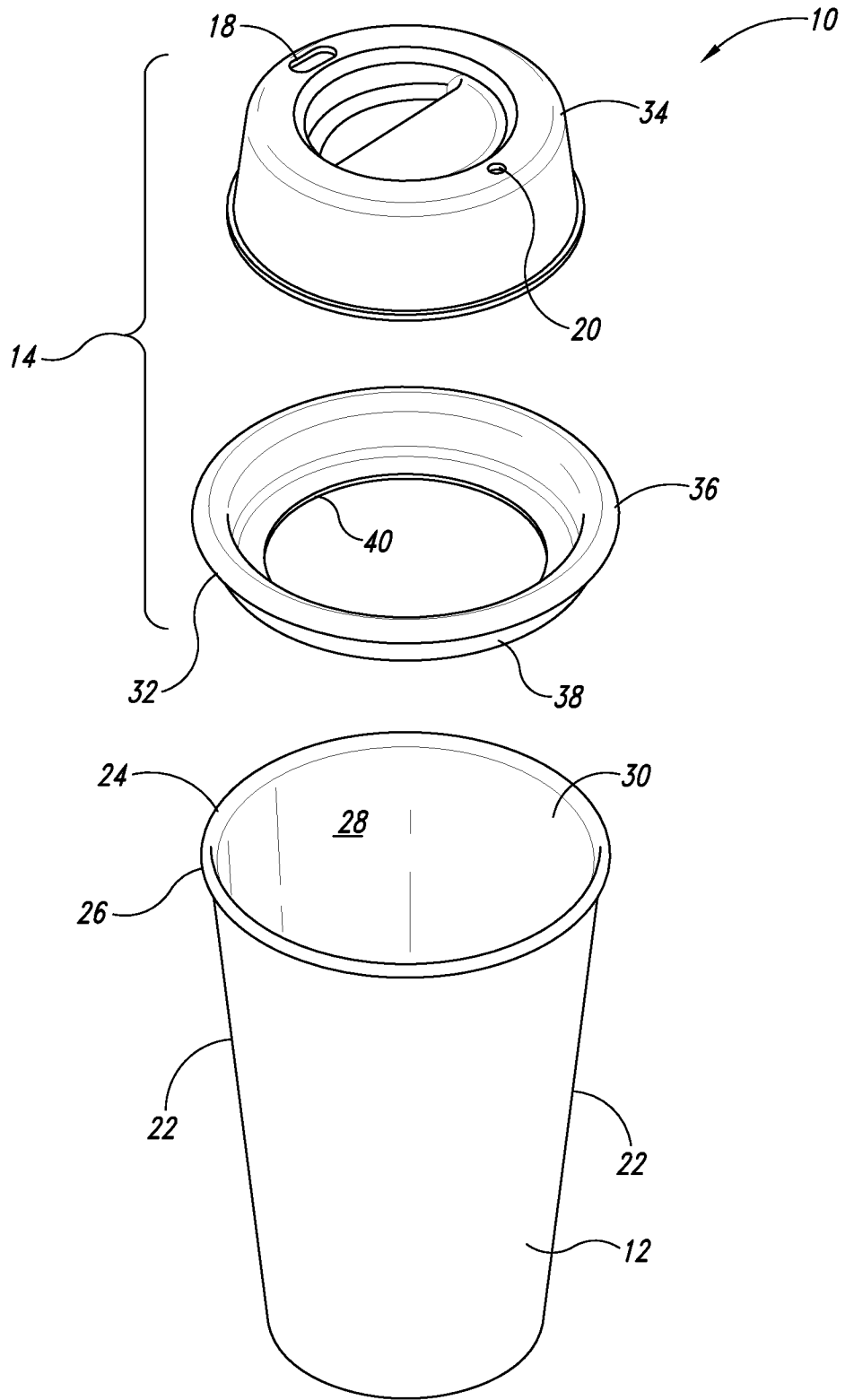
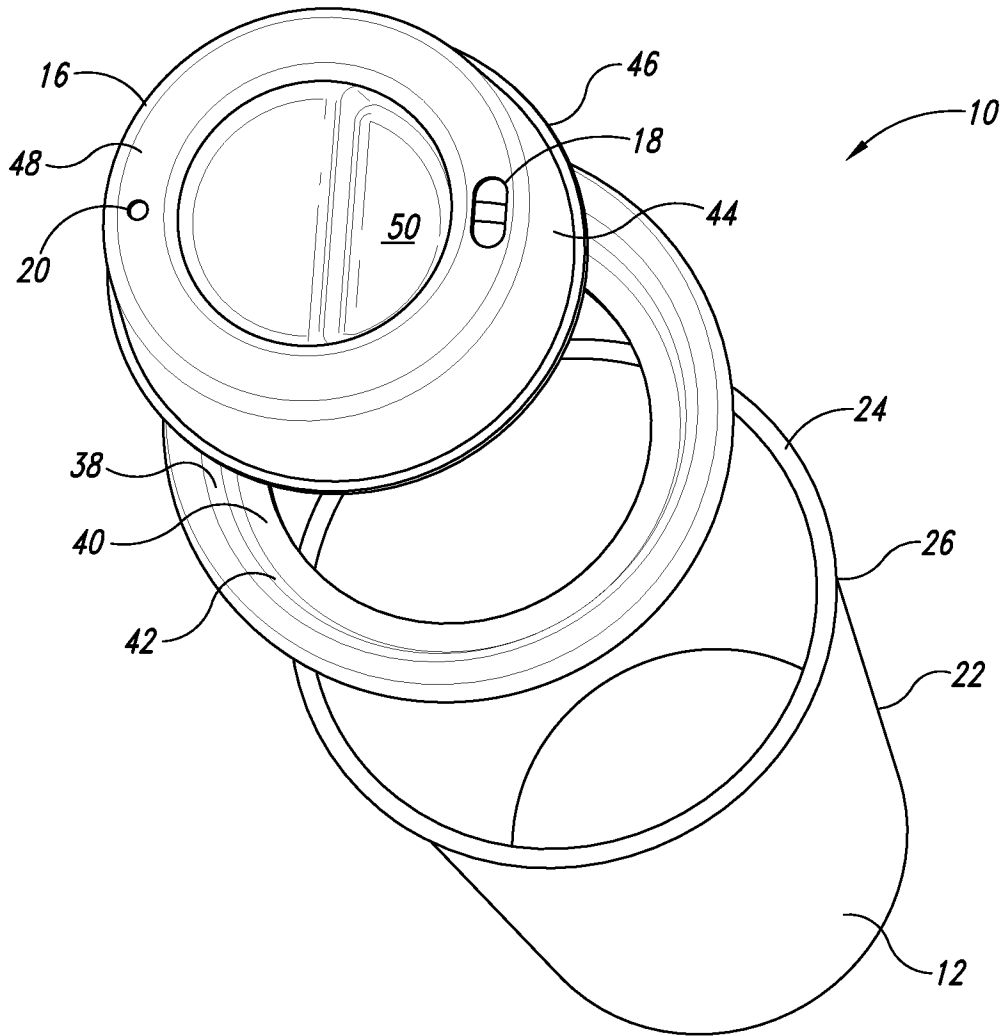


Fig. 2



*Fig. 3*

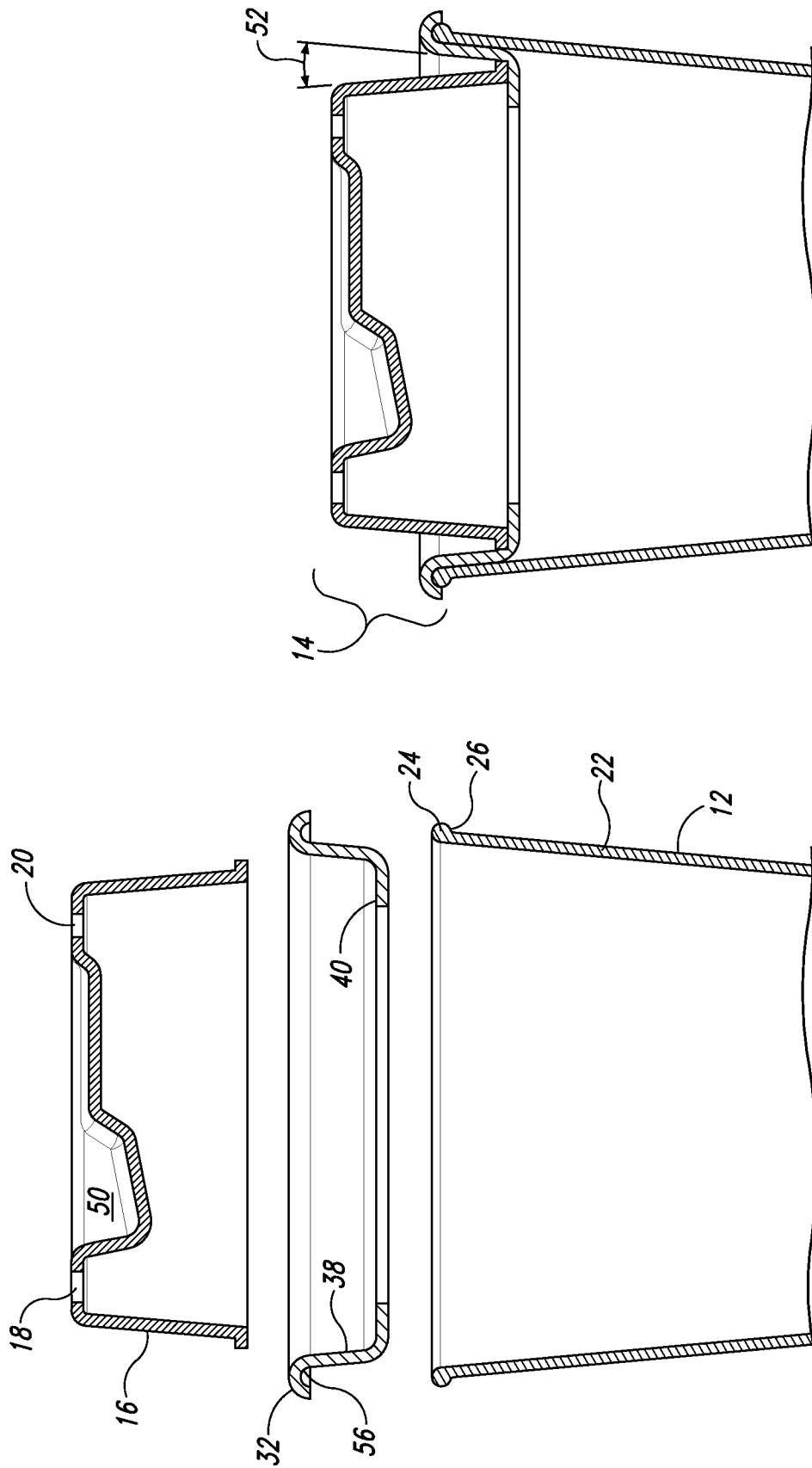
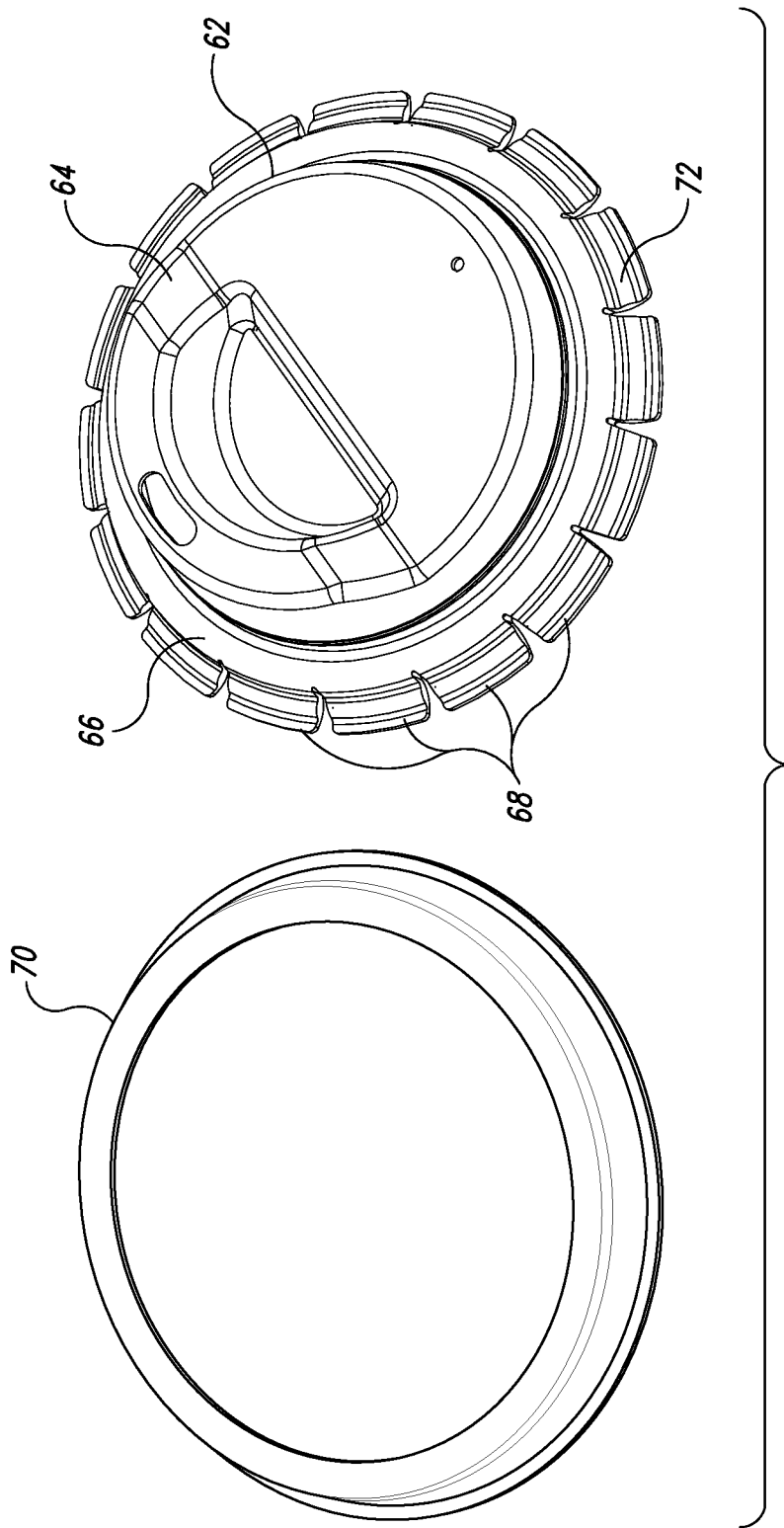


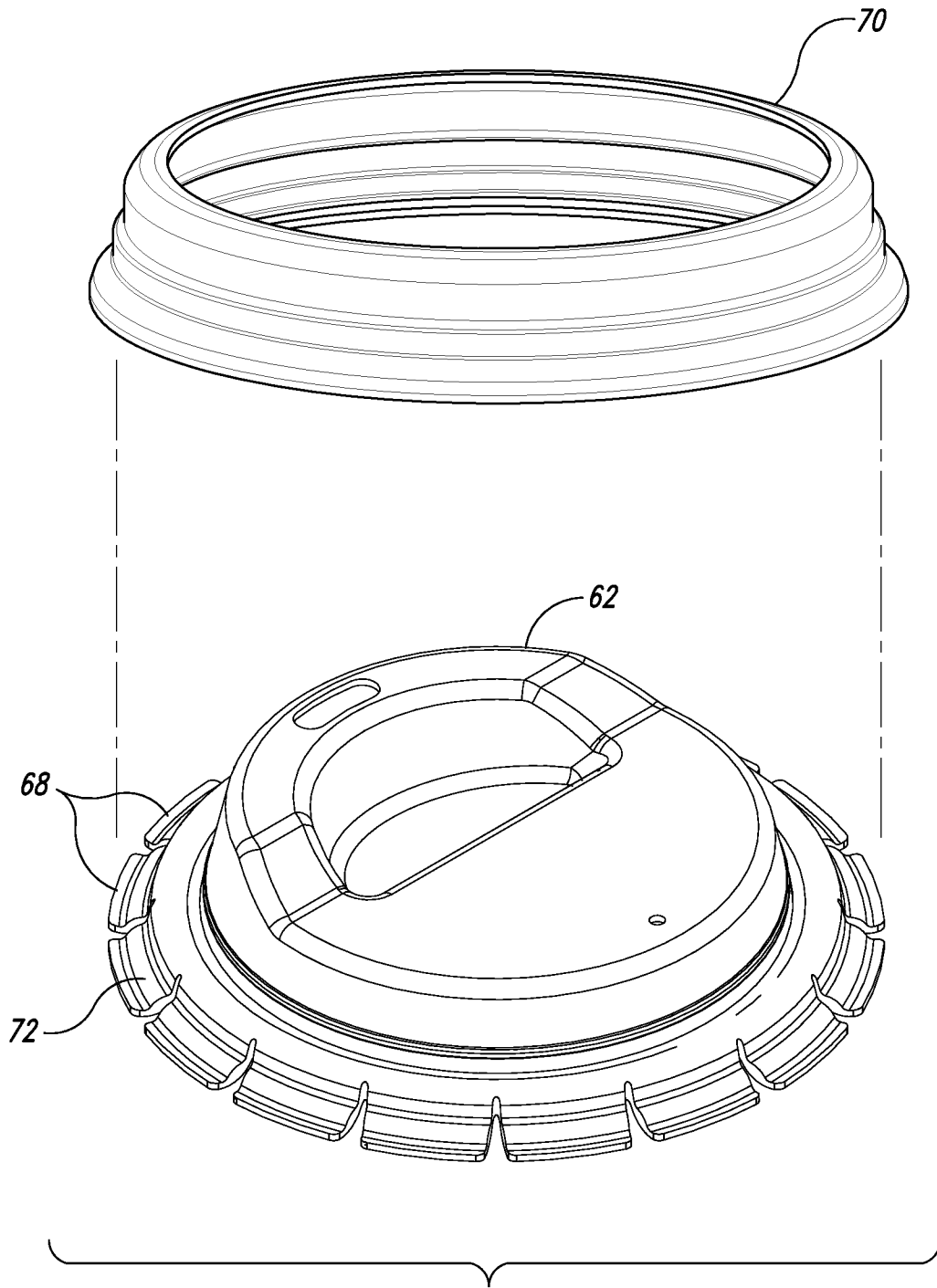
Fig. 5

Fig. 4

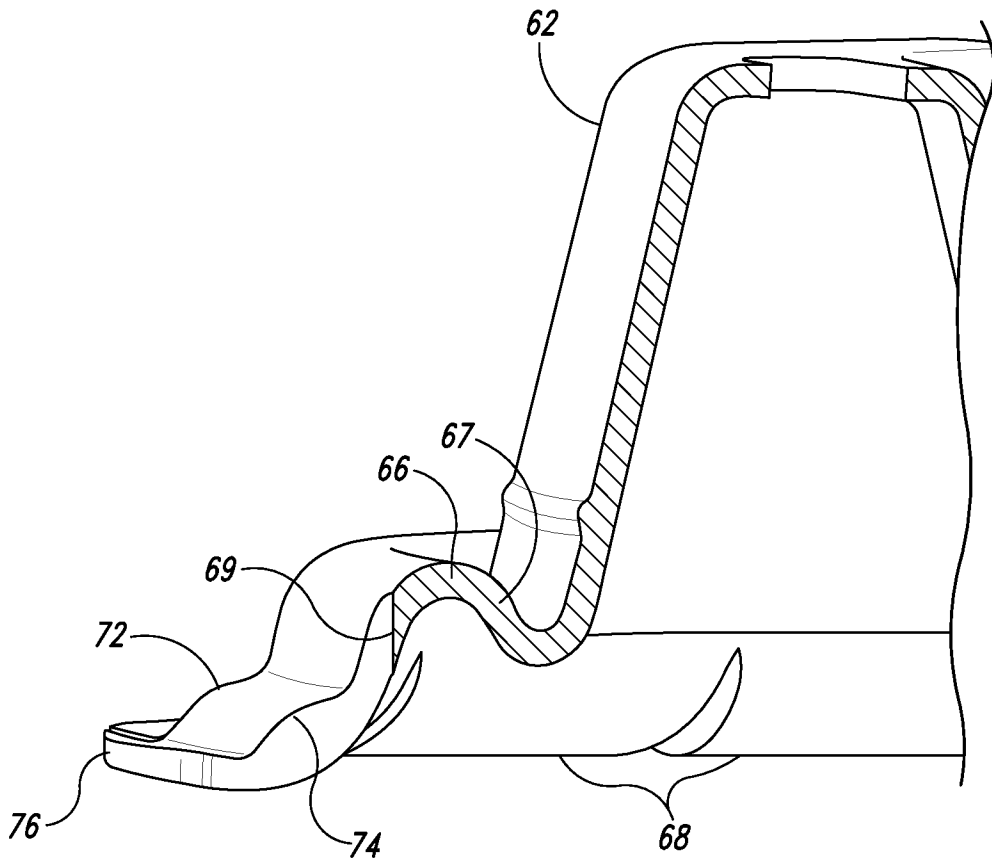


*Fig. 6*

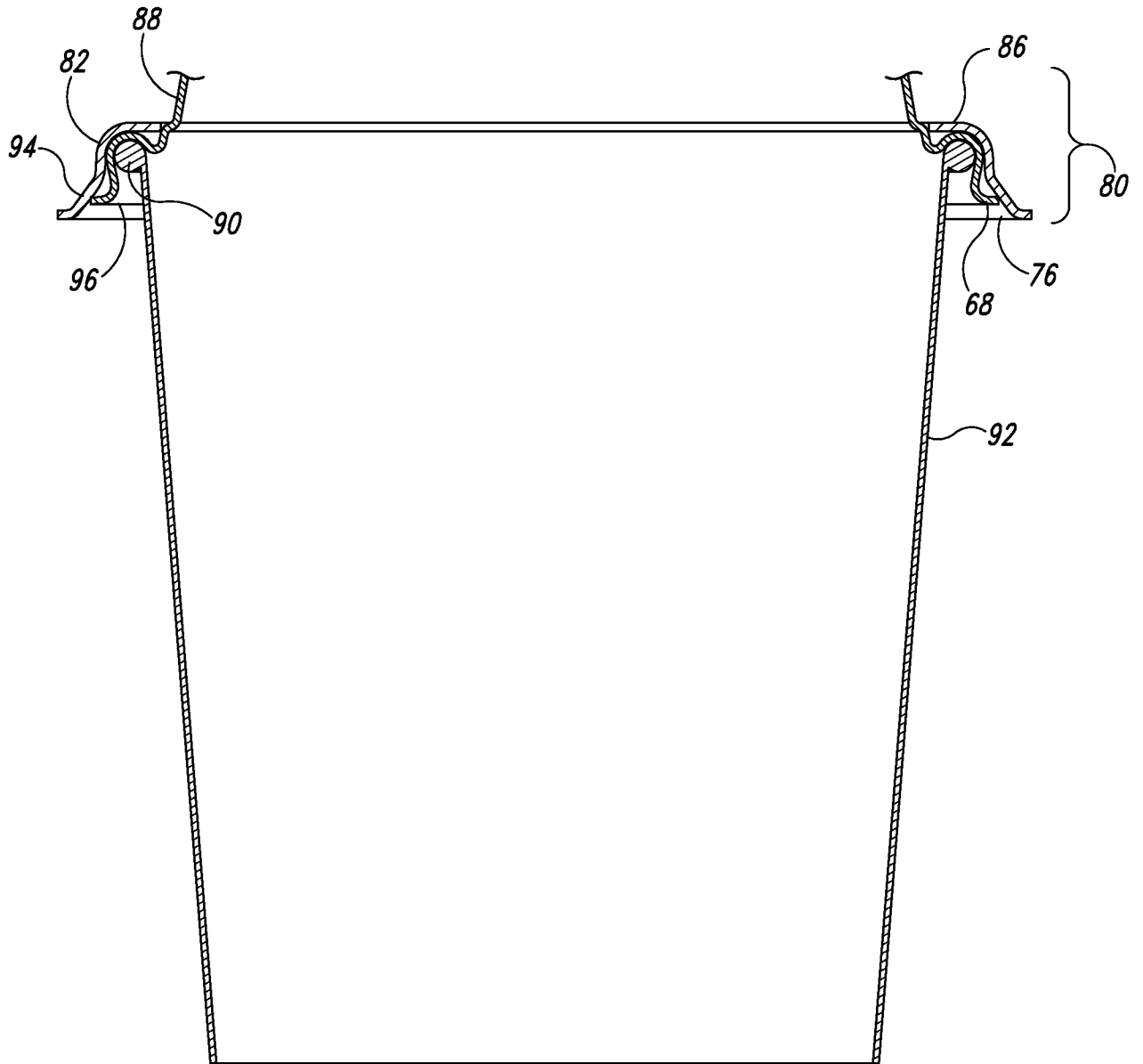
6/19



*Fig. 7*



*Fig. 8*



*Fig. 9*

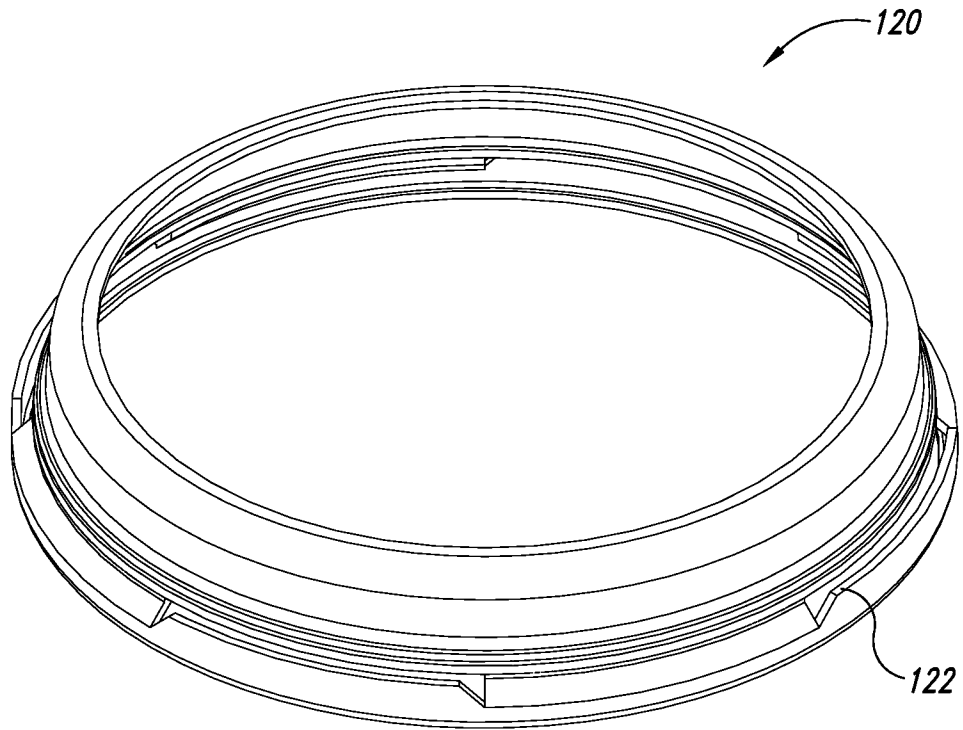


*Fig. 10*

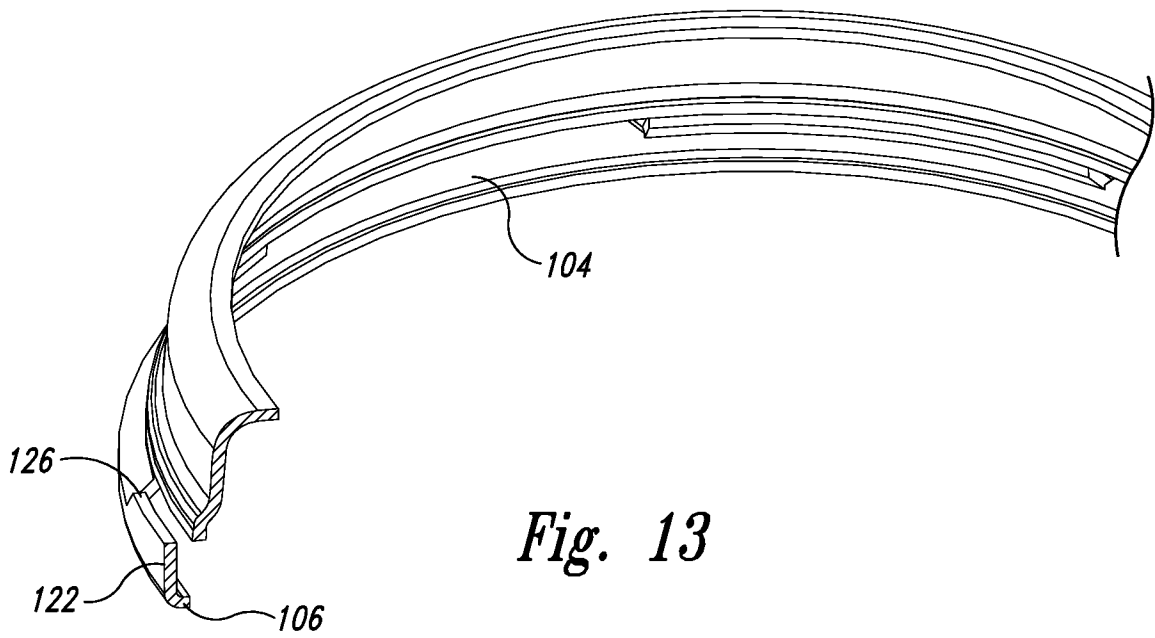


*Fig. 11*

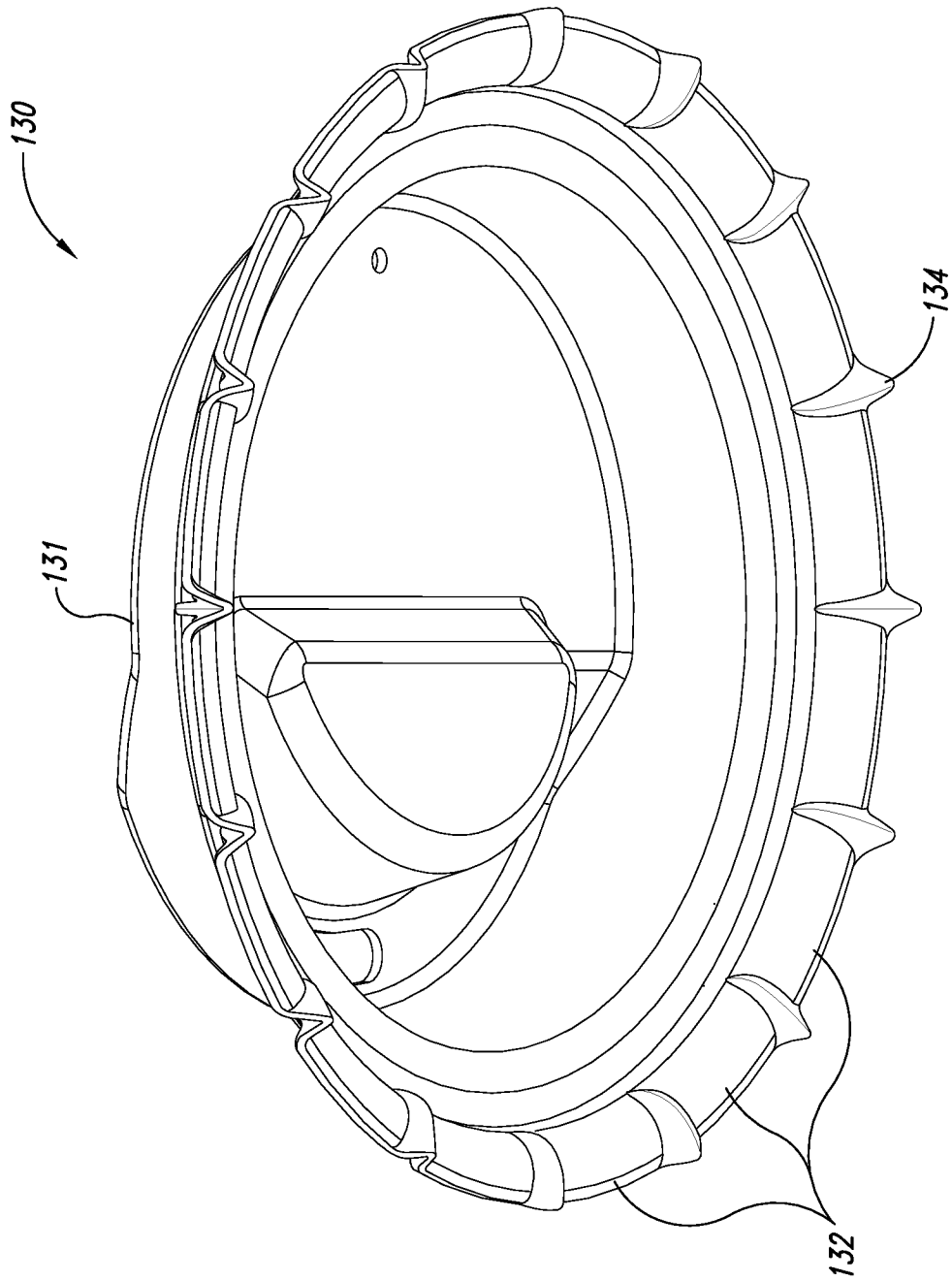
10/19



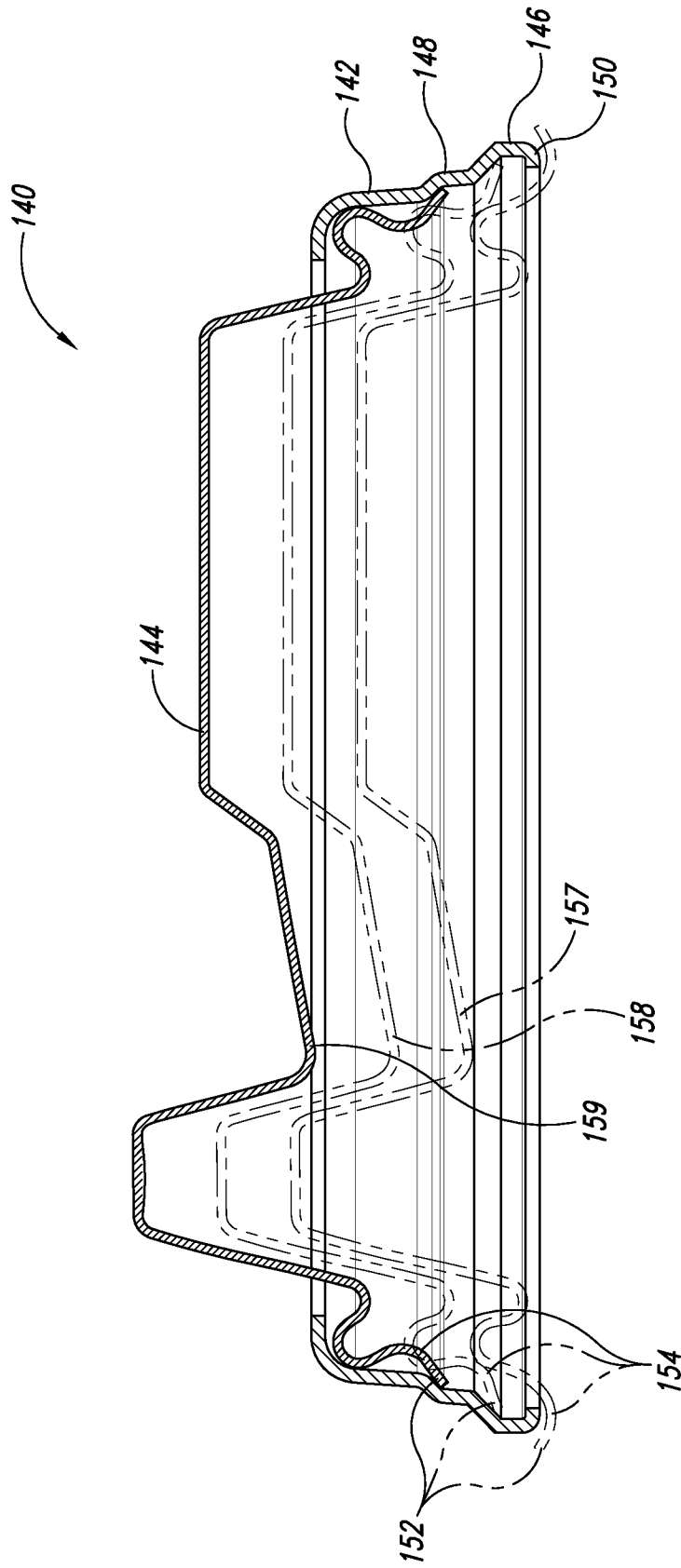
*Fig. 12*



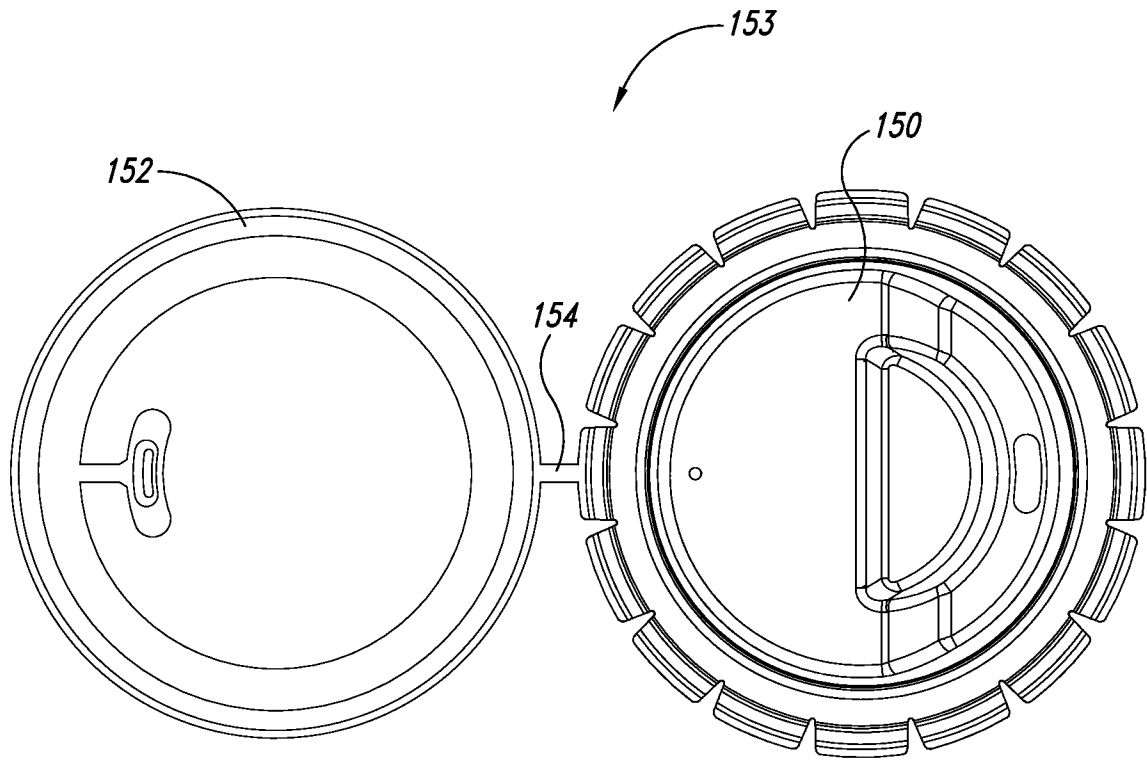
*Fig. 13*



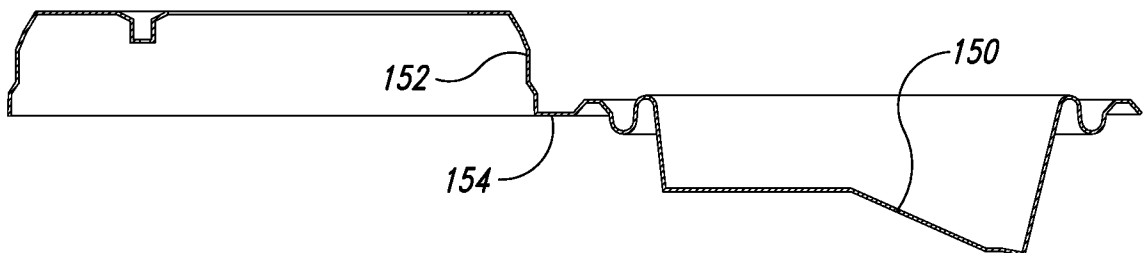
*Fig. 14*



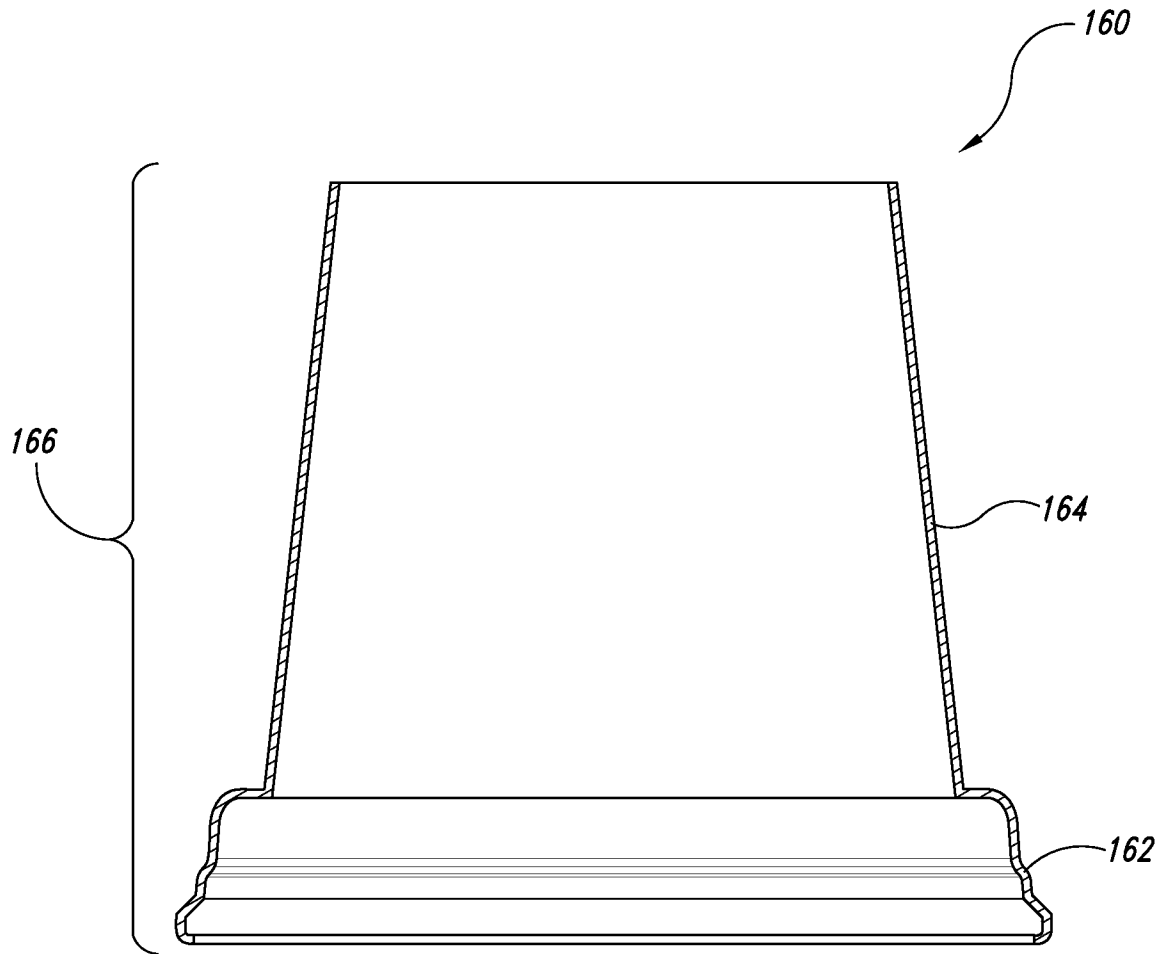
*Fig. 15*



*Fig. 16A*

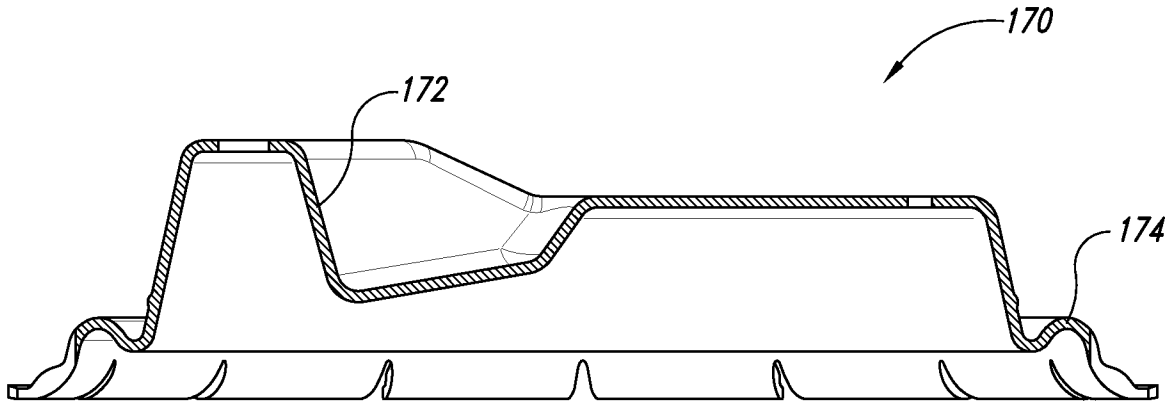


*Fig. 16B*

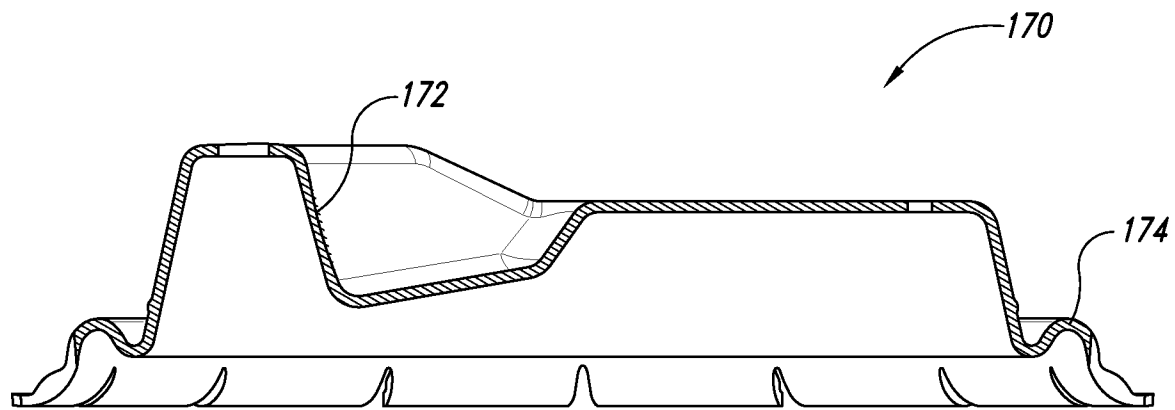


*Fig. 17*

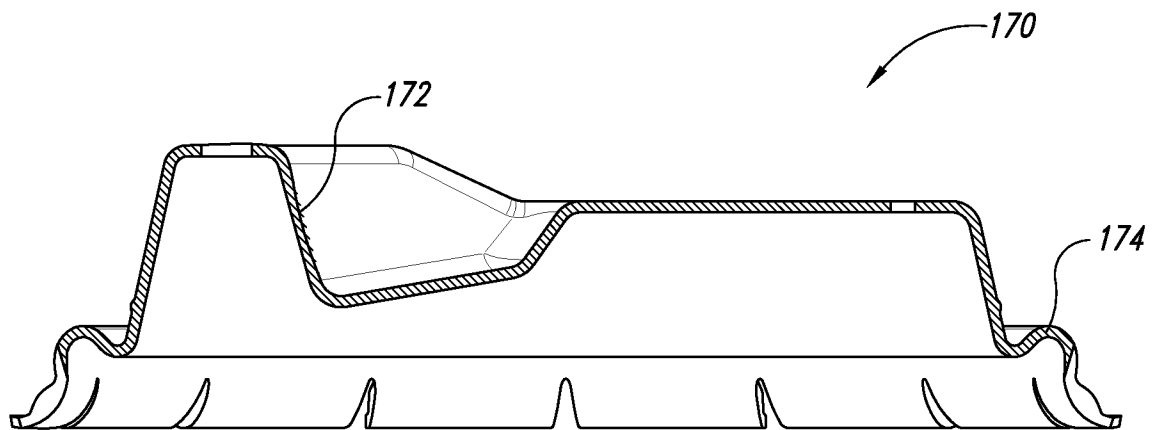
15/19



*Fig. 18A*

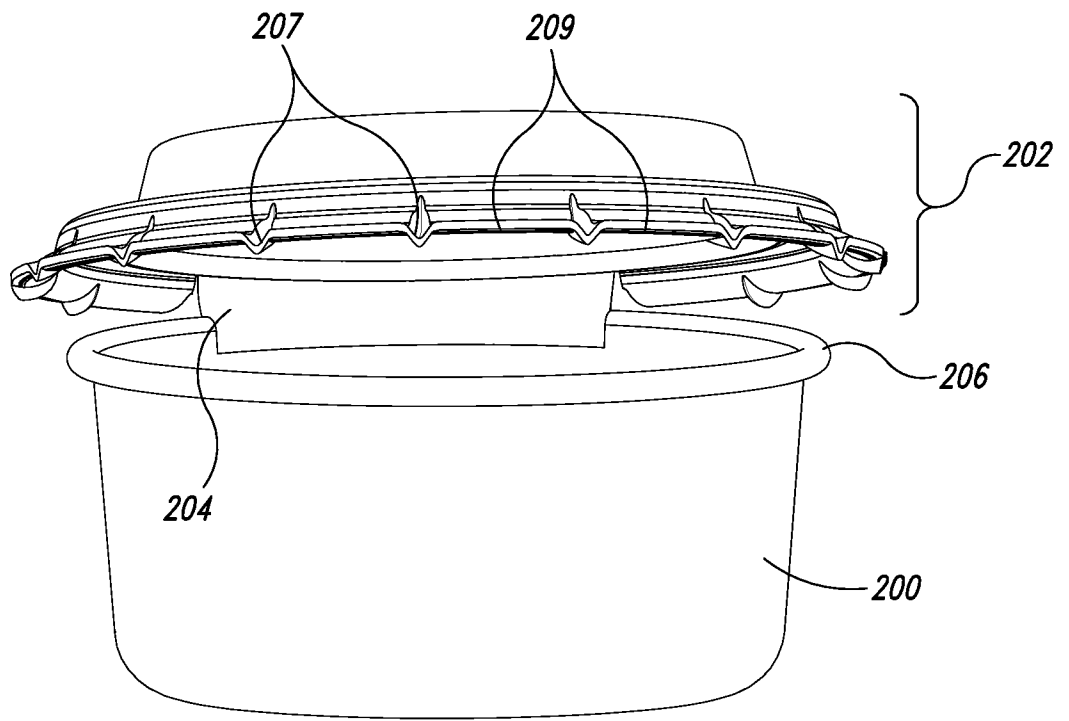


*Fig. 18B*

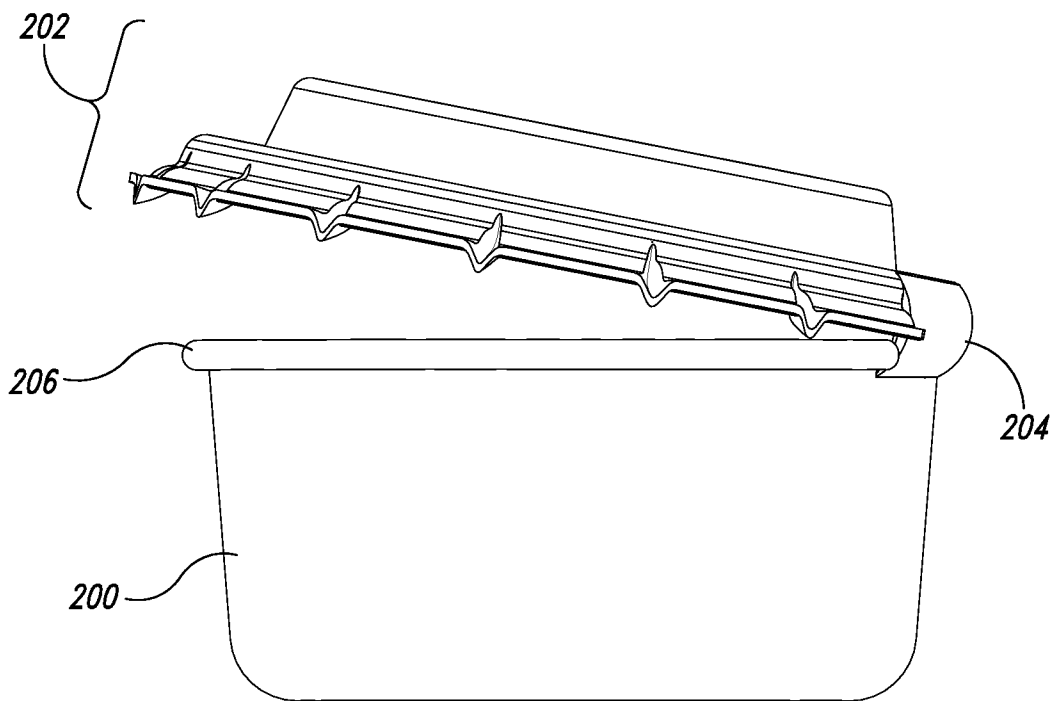


*Fig. 18C*

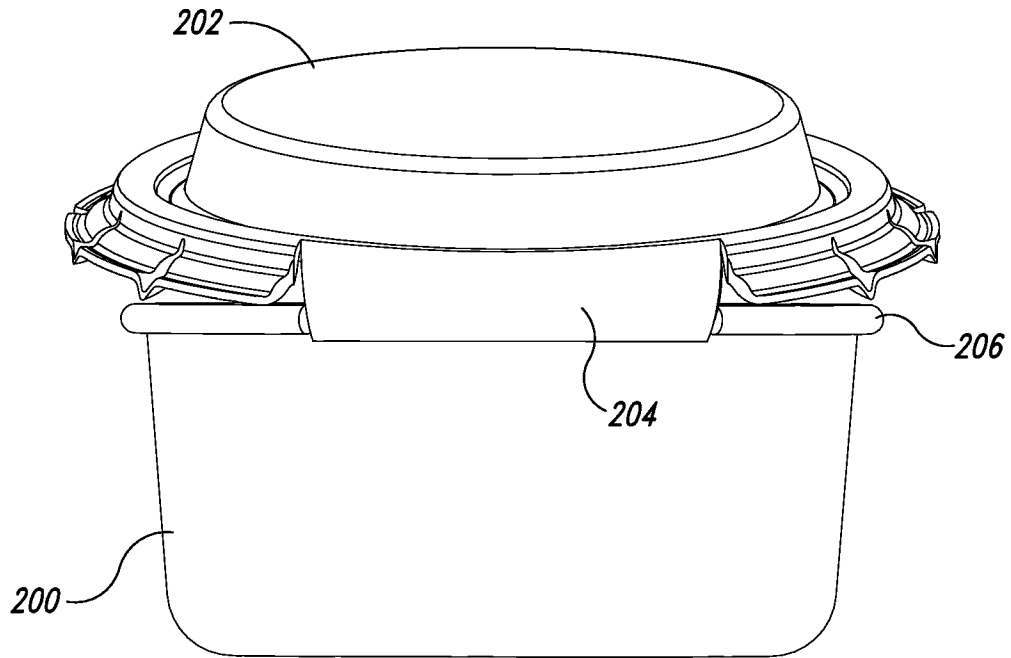
16/19



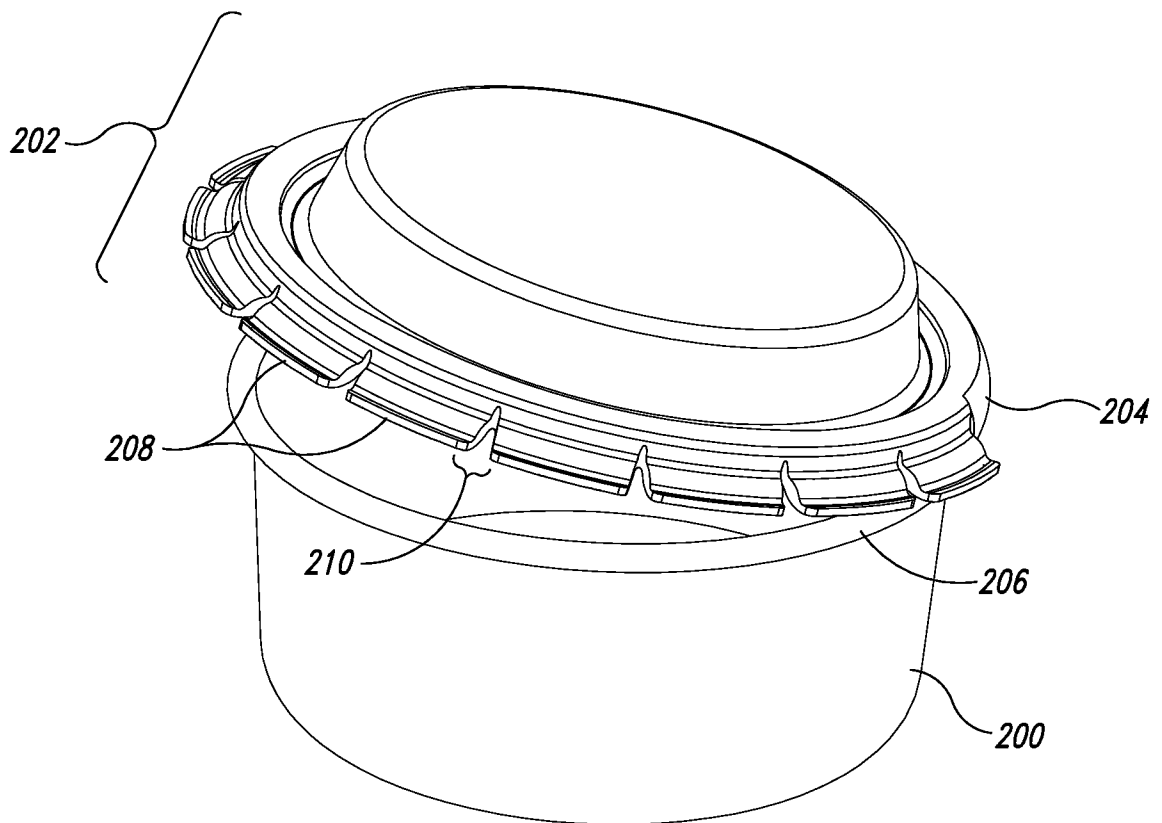
*Fig. 19*



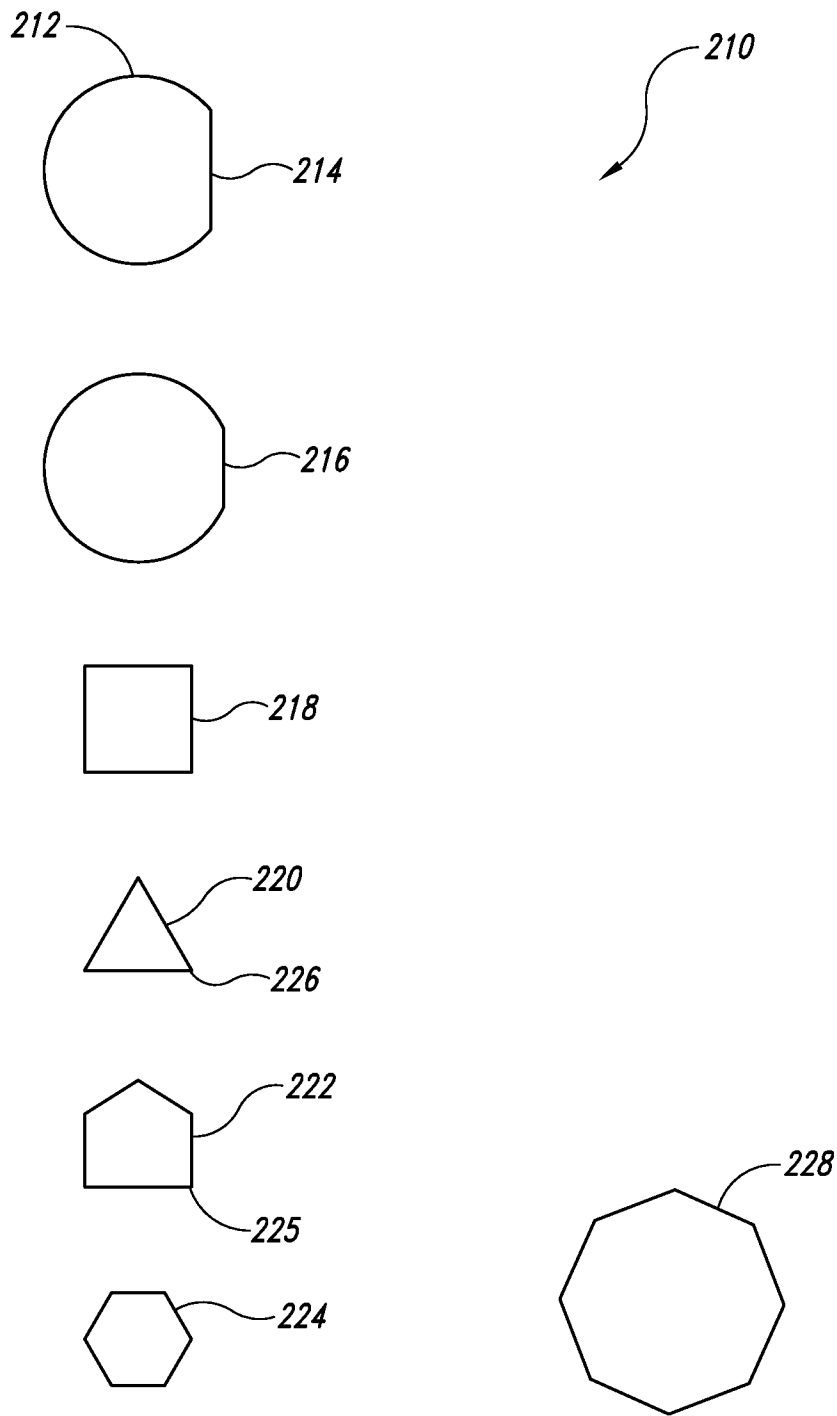
*Fig. 20*



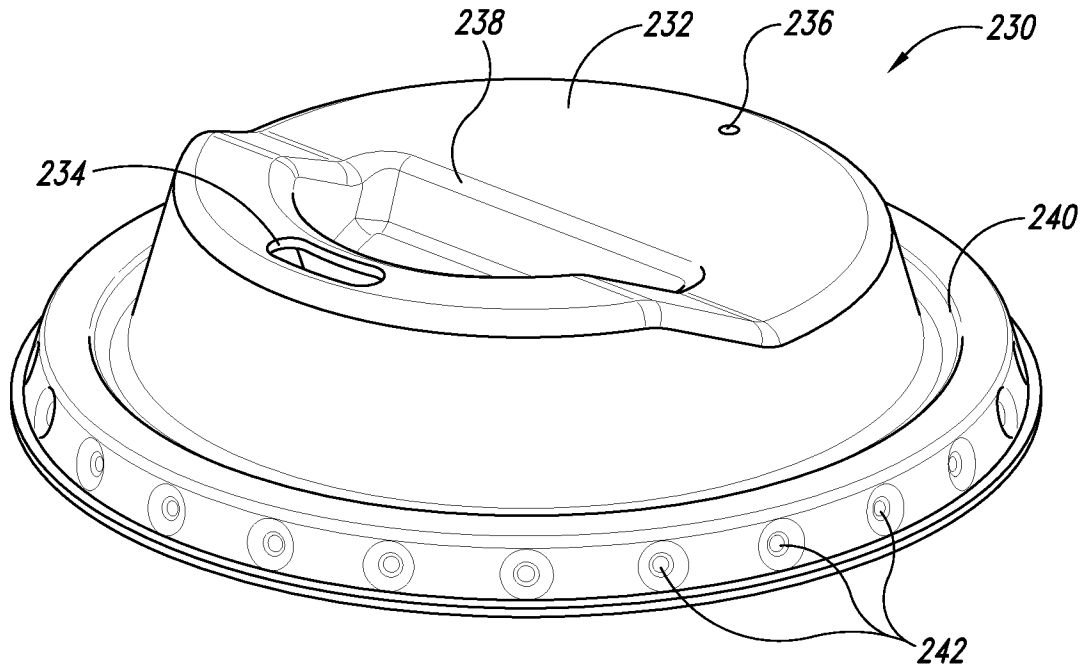
*Fig. 21*



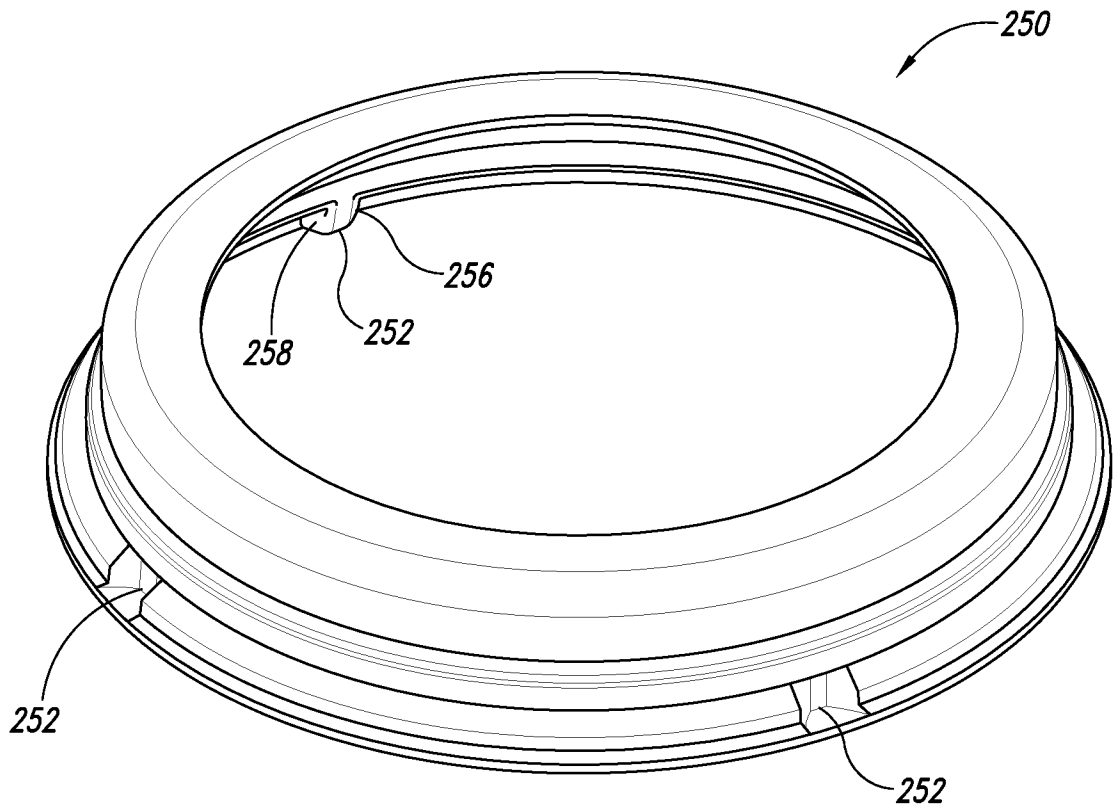
*Fig. 22*



*Fig. 23*



*Fig. 24*



*Fig. 25*

**INTERNATIONAL SEARCH REPORT**

International application No.

PCT/US 09/41731

**A. CLASSIFICATION OF SUBJECT MATTER**  
 IPC(8) - C08L 101/16; C08L 97/02 (2009.01)  
 USPC - 106/162.5, 164.01  
 According to International Patent Classification (IPC) or to both national classification and IPC

**B. FIELDS SEARCHED**

Minimum documentation searched (classification system followed by classification symbols)  
 IPC(8) -- C08L 101/16; C08L 97/02 (2009.01) and USPC -- 106/162.5, 164.01

Documentation searched other than minimum documentation to the extent that such documents are included in the fields searched  
 IPC(8) -- B29C5; B29D5; B21J5; B65D5; C08L 5/00 (2009.01)

Electronic data base consulted during the international search (name of data base and, where practicable, search terms used)  
 PubWest (PGPB,USPT,EPAB,JPAB); USPTO; Espacenet; Google Patents; Google Scholar; Google -- please see extra sheet for Search Terms Used

**C. DOCUMENTS CONSIDERED TO BE RELEVANT**

Category*	Citation of document, with indication, where appropriate, of the relevant passages	Relevant to claim No.
Y	US 5,385,255 A (Varano et al.) 31 January 1995 (31.01.1995) Fig 2, 3; col 1, ln 38-41; col 1, ln 54-57; col 2, ln 20-23; col 3, ln 15-16	1-31
Y	US 3,727,808 A (Fitzgerald) 17 April 1973 (17.04.1973) Figs 1-5, 7-9, 14; col 2, ln 43-45; col 2, ln 58-63; col 3, ln 12-18	1-31
Y	US 5,284,270 A (Kusta) 08 February 1994 (08.02.1994) Figs 1, 3 and 4; col 1, 10-13; col 2, ln 65-68;	1-31
Y	US 5,036,994 A (McElroy) 06 August 1991 (06.08.1991) Fig 11; col 3, ln 1-3	5
Y	US 7,124,910 B2 (Nordland) 24 October 2006 (24.10.2006) Figs 1-3; col 1, ln 15-21; col 1, ln 39-55	14-16, 21, 23-31
Y	US 5,241,801 A (Nelson) 07 September 1993 (07.09.1993) Abstract; col 6, ln 50-68; col 7, ln 1-10	21

Further documents are listed in the continuation of Box C.

\* Special categories of cited documents:

"A" document defining the general state of the art which is not considered to be of particular relevance	"T" later document published after the international filing date or priority date and not in conflict with the application but cited to understand the principle or theory underlying the invention
"E" earlier application or patent but published on or after the international filing date	"X" document of particular relevance; the claimed invention cannot be considered novel or cannot be considered to involve an inventive step when the document is taken alone
"L" document which may throw doubts on priority claim(s) or which is cited to establish the publication date of another citation or other special reason (as specified)	"Y" document of particular relevance; the claimed invention cannot be considered to involve an inventive step when the document is combined with one or more other such documents, such combination being obvious to a person skilled in the art
"O" document referring to an oral disclosure, use, exhibition or other means	"&" document member of the same patent family
"P" document published prior to the international filing date but later than the priority date claimed	

Date of the actual completion of the international search 08 June 2009 (08.06.2009)	Date of mailing of the international search report <b>15 JUN 2009</b>
--	--

Name and mailing address of the ISA/US Mail Stop PCT, Attn: ISA/US, Commissioner for Patents P.O. Box 1450, Alexandria, Virginia 22313-1450 Facsimile No. 571-273-3201	Authorized officer: Lee W. Young  PCT Helpdesk: 571-272-4300 PCT OSP: 571-272-7774
---	--

INTERNATIONAL SEARCH REPORT

International application No.

PCT/US 09/41731

Search Terms Used:

BEVERAGE BIODEGRADABLE BUCKET CAN CLOSURE COFFEE COLLAR COMPOSTABLE COMPRESS COMPRESSED  
COMPRESSION CONTAINER CUP COVER DOME FLANGE FOOD LID PAIL PAINT PRESS PRESSED REUSE REUSABLE RING  
RETAINING SEAL SEALED SEALING SERRATED SERRATIONS SHRINK SHRINKFILM SHRINKBAND SHRINKWRAP SNAP  
SNAPPING SNAPFIT SNAP-FIT SPOUT TABS TWO-PART TWO-PIECE VENT