



(51) International Patent Classification:

A61B 18/12 (2006.01) A61B 17/285 (2006.01)
A61B 18/14 (2006.01) A61B 17/3201 (2006.01)

(21) International Application Number:

PCT/US2014/066432

(22) International Filing Date:

19 November 2014 (19.11.2014)

(25) Filing Language:

English

(26) Publication Language:

English

(30) Priority Data:

61/906,337 19 November 2013 (19.11.2013) US

(72) Inventor; and

(71) Applicant : RYAN, D., Smith [US/US]; 18 Magnus Avenue #2, Somerville, MA 02143 (US).

(74) Agent: ALTMAN, Daniel, E.; Knobbe Martens Olson & Bear, LLP, 2040 Main Street, 14th Floor, Irvine, CA 92614 (US).

(81) Designated States (unless otherwise indicated, for every kind of national protection available): AE, AG, AL, AM, AO, AT, AU, AZ, BA, BB, BG, BH, BN, BR, BW, BY,

BZ, CA, CH, CL, CN, CO, CR, CU, CZ, DE, DK, DM, DO, DZ, EC, EE, EG, ES, FI, GB, GD, GE, GH, GM, GT, HN, HR, HU, ID, IL, IN, IR, IS, JP, KE, KG, KN, KP, KR, KZ, LA, LC, LK, LR, LS, LU, LY, MA, MD, ME, MG, MK, MN, MW, MX, MY, MZ, NA, NG, NI, NO, NZ, OM, PA, PE, PG, PH, PL, PT, QA, RO, RS, RU, RW, SA, SC, SD, SE, SG, SK, SL, SM, ST, SV, SY, TH, TJ, TM, TN, TR, TT, TZ, UA, UG, US, UZ, VC, VN, ZA, ZM, ZW.

(84) Designated States (unless otherwise indicated, for every kind of regional protection available): ARIPO (BW, GH, GM, KE, LR, LS, MW, MZ, NA, RW, SD, SL, ST, SZ, TZ, UG, ZM, ZW), Eurasian (AM, AZ, BY, KG, KZ, RU, TJ, TM), European (AL, AT, BE, BG, CH, CY, CZ, DE, DK, EE, ES, FI, FR, GB, GR, HR, HU, IE, IS, IT, LT, LU, LV, MC, MK, MT, NL, NO, PL, PT, RO, RS, SE, SI, SK, SM, TR), OAPI (BF, BJ, CF, CG, CI, CM, GA, GN, GQ, GW, KM, ML, MR, NE, SN, TD, TG).

Published:

- with international search report (Art. 21(3))
- before the expiration of the time limit for amending the claims and to be republished in the event of receipt of amendments (Rule 48.2(h))

(54) Title: SURGICAL MULTI-TOOL AND METHOD OF USE

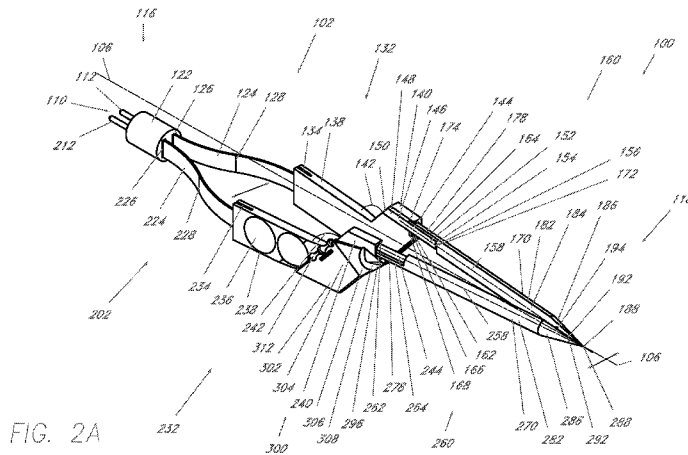
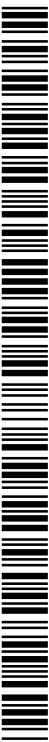

FIG. 2A

(57) Abstract: Surgical tools are disclosed that include a first handle having a first recess, a second handle having a second recess, a first tip disposed in the first recess and extending distally, and a second tip disposed in the second recess and extending distally. The first tip has a first external surface and a first internal surface. The second tip has a second external surface and a second internal surface. The surgical tool has a first configuration wherein the surgical tool operates as forceps. The surgical tool has a second configuration wherein the surgical tool operates as scissors. The first internal surface can be moved adjacent to the second internal surface to permit rotation of the first tip relative to the first recess and permit rotation of the second tip relative to the second recess. The rotation of the first tip and the second tip transitions the surgical tool between the first configuration and the second configuration.



SURGICAL MULTI-TOOL AND METHOD OF USE

INCORPORATION BY REFERENCE TO ANY PRIORITY APPLICATIONS

[0001] The present application claims priority benefit under 35 U.S.C. § 119(e) of U.S. Provisional Patent Application No. 61/906337 filed November 19, 2013, the disclosure of which is incorporated by reference herein in its entirety.

BACKGROUND OF THE INVENTION

Field of the Invention

[0002] The present application relates to the field of medical devices, and encompasses apparatuses for use during surgery and surgical methods. In particular, the application relates to surgical hand tools having a plurality of configurations including a forceps configuration and a scissors configuration.

Description of the Related Art

[0003] Surgical tools typically serve a single function. Surgical scissors are useful for cutting tissue. Surgical forceps are useful for manipulating tissues. Electrosurgical devices are useful for cauterization, hemostasis, and for tissue dissection. Electrosurgical devices most commonly involve radiofrequency (RF) energy wherein a voltage gradient is produced between two points and current flows through the tissue, dissipating energy as heat. This in turn allows refolding of protein and coagulation or dissection of tissue.

[0004] Each surgical tool has limitations. For instance, in relation to electrosurgical devices, the passage of current through the tissue does not allow cutting of all tissues. This limitation is pronounced when the distance between the two contact points of the device is increased. Furthermore, tissue cutting can be accomplished more quickly with scissors in many instances where cauterization is not needed for hemostasis.

SUMMARY OF THE INVENTION

[0005] In some embodiments, a surgical tool (sometimes referred to as a hand tool) is provided. The surgical tool can include a first handle comprising a proximal portion and a distal portion and a first recess in the distal portion. The surgical tool can

include a second handle comprising a proximal portion and a distal portion and a second recess in the distal portion. The surgical tool can include a first tip disposed in the first recess and extending distally therefrom, the first tip having a first external surface and a first internal surface. The surgical tool can include a second tip disposed in the second recess and extending distally therefrom, the second tip having a second external surface and a second internal surface. In some embodiments, the surgical tool has a first configuration wherein the first and second tips operate as forceps. In some embodiments, the surgical tool has a second configuration wherein the first and second tips operate as scissors. In some embodiments, rotation of the first tip and the second tip within their respective recesses transitions the surgical tool between the first configuration and the second configuration.

[0006] In some embodiments, the first inner surface and the second inner surface are configured to abut each other during rotation of the first tip and the second tip within their respective recesses to transition the surgical tool between the first configuration and the second configuration. In some embodiments, the second tip comprises a pin extending from the second external surface, and rotation of the pin relative to the second handle causes rotation of the second tip relative to the second recess and transitions the surgical tool between the first configuration and the second configuration. In some embodiments, rotation of the pin relative to the second handle rotates the first tip relative to the first recess. In some embodiments, the pin is substantially perpendicular to a longitudinal axis of the second tip. In some embodiments, the first tip comprises a first electrode and the second tip comprises a second electrode. In some embodiments, the first tip and the second tip are configured to interact as electrocautery bipolar forceps in the first configuration. In some embodiments, in the second configuration, the first and second inner surfaces are configured to shear past each other. In some embodiments, one of the first tip and the second tip comprises a recess and the other of the first tip and the second tip comprises a protrusion, wherein the protrusion is configured to be received relative to the recess in the second configuration to provide an axis about which the tips can rotate. In some embodiments, the surgical tool can include a sleeve surrounding at least a portion of the first tip. In some embodiments, the surgical tool can include a locking mechanism configured to prevent rotation of the second tip. In some embodiments, the first handle is coupled to the second handle near a proximal end of the surgical tool. In some embodiments, the surgical tool can include one

or more springs attached to the handles to bias the first and second tips to a neutral position.

[0007] In some embodiments, a method of using a surgical tool is provided. The method can include the step of providing a first handle and a second handle coupled to each other, the first handle having a first tip extending distally therefrom and the second handle having a second tip extending distally therefrom, wherein the first and second tips are configured for use as forceps. The method can include the step of rotating the first tip relative to the first handle and rotating the second tip relative to the second handle, wherein the rotation reconfigures the first and second tips for use as scissors.

[0008] The method can include the step of bringing inner surfaces of the first and second tips into contact with each other so that longitudinal axes of the first and second tips are aligned, and then rotating the first tip relative to the first handle and rotating the second tip relative to the second handle. In some embodiments, after rotating the first tip relative to the first handle and rotating the second tip relative to the second handle, the inner surfaces of the first and second tips are configured to shear past each other. The method can include the step of rotating a pin extending from one of the first tip and the second tip to rotate the first tip relative to the first handle and rotate the second tip relative to the second handle. The method can include the step of applying electrical energy to tissue with the first tip and the second tip. In some embodiments, rotating the first tip relative to the first handle and the second tip relative to the second handle further comprises rotating the first tip ninety degrees and rotating the second tip ninety degrees.

[0009] In some embodiments, a surgical tool is provided. The surgical tool can include a first handle. The surgical tool can include a first tip coupled to the first handle and configured to rotate relative to the first handle, the first tip having a first internal surface. The surgical tool can include a second handle. The surgical tool can include a second tip coupled to the second handle and configured to rotate relative to the second handle, the second tip having a second internal surface. In some embodiments, the surgical tool has a first configuration wherein the first internal surface and the second internal surface are generally vertical. In some embodiments, movement of the first handle or the second handle changes the distance between the first tip and the second tip in the first configuration. In some embodiments, the surgical tool has a second configuration wherein the first internal surface and the second internal surface are generally horizontal. In some embodiments, movement of the first handle or the second

handle shears an edge of the first tip past an edge of the second tip in the second configuration. In some embodiments, the tips are configured to rotate to transition between the first configuration and the second configuration.

[0010] In some embodiments, a surgical tool is provided. The surgical tool can include a first handle and a second handle. In some embodiments, the first handle and the second handle are configured to have a first configuration and a second configuration. In some embodiments, in the first configuration the tool operates as forceps and in the second configuration the tool operates as scissors.

[0011] The surgical tool or hand tool can be used in surgical sites with limited lateral access and substantial depth. The multiple configurations can allow for tissue dissection by cutting and electrocautery. The interchangeability of the hand tool limits the number of times the hand tool would need to be removed, exchanged, and re-inserted into the surgical site. The interchangeability can limit the potential for injury, while improving usability and efficiency.

[0012] The surgical tool or hand tool of certain embodiments advantageously provides multiple functional configurations that are easily interchanged by the user. The hand tool is capable of use in open microsurgery, minimally invasive surgery, and other surgical environments. The hand tool may be a single handheld device, which allows the interchangeability of configurations without the user removing the device from the local surgical field.

BRIEF DESCRIPTION OF THE DRAWINGS

[0013] These and other features, aspects, and advantages of the invention disclosed herein are described below with reference to the drawings of preferred embodiments, which are intended to illustrate and not to limit the invention. Additionally, from figure to figure, the same reference numerals have been used to designate the same components of an illustrated embodiment. The following is a brief description of each of the drawings.

[0014] Figure 1 is an exploded view of a hand tool.

[0015] Figure 2A is a perspective view of the hand tool of Figure 1 in the forceps configuration.

[0016] Figure 2B is a top view of the hand tool of Figure 1 in the forceps configuration.

[0017] Figure 3 is a perspective view of the hand tool of Figure 1, wherein the tips are brought together to change configurations.

[0018] Figure 4 is a perspective view of the hand tool of Figure 1 in the scissors configuration.

[0019] Figure 5A is a front view of the hand tool of Figure 1 in the forceps configuration; Figure 5B is a cross-sectional view taken along line B-B in Figure 5A.

[0020] Figure 6A is a front view of the hand tool of Figure 1 in the scissors configuration; Figure 6B is a cross-sectional view taken along line M-M in Figure 6A.

[0021] Figure 7A is a side view of the hand tool of Figure 1 in the forceps configuration; Figure 7B is a cross-sectional view taken along line D-D in Figure 7A; Figure 7C is a cross-sectional view taken along line G-G in Figure 7A.

[0022] Figure 8A is a side view of the hand tool of Figure 1 in the scissors configuration; Figure 8B is a cross-sectional view taken along line P-P in Figure 8A; Figure 8C is a cross-sectional view taken along line T-T in Figure 8A.

[0023] Figure 9A is a perspective view of a hand tool in the scissors configuration with a sleeve; Figure 9B is a top view of the hand tool of Figure 9A; Figure 9C is side view of the hand tool of Figure 9A; and Figure 9D is a cross-sectional view taken along line K-K in Figure 9A.

[0024] Figure 10A is a perspective view of the hand tool in the scissors configuration with a locking mechanism; Figure 10B is a top view of the hand tool of Figure 10A; Figure 10C is a side view of the hand tool of Figure 10A.

DETAILED DESCRIPTION OF THE PREFERRED EMBODIMENTS

[0025] Preferred embodiments of the surgical hand tool include two sections used together to perform a function. One or more of the sections can comprise segments, portions, components, or subcomponents. However, the use of the term “section” does not imply any particular structure or configuration. In some embodiments, the right section or components thereof are mirror image, identical, or substantially similar to the left section or components thereof. The sections or components thereof may be any suitable shape that permits the function of the hand tool, for instance perform the function of scissors and forceps. Certain embodiments are illustrated and/or described herein.

[0026] With reference to Figures 1-2A, a hand tool 100 is shown. The hand tool 100 can also be referred to as a surgical multi-tool. The hand tool 100 comprises two

sections: a left section 102 and a right section 202. In the illustrated configuration, the left section 102 includes multiple components and the right section 202 includes multiple components as described further below. The left section 102 interacts with the right section 202 to perform one or more functions, such as operating as forceps and scissors as described in detail below. The hand tool 100 has a longitudinal axis 106 that extends between a proximal end 116 and a distal end 118. The left section 102 can be on the left side of the longitudinal axis 106 when the hand tool 100 is viewed from the top. The right section 202 can be on the right side of the longitudinal axis 106 when the hand tool 100 is viewed from the top.

[0027] The surgical hand tool 100 can transition between functional configurations. As illustrated in Figures 1 and 2A, the left section 102 can comprise a left handle 132 and a left tip 160 extending distally from the left handle 132. The right section 202 can comprise a right handle 232 and a right tip 260 extending distally from the right handle 232. The surgical hand tool can operate as forceps, which can also be referred to as the forceps configuration, with the left tip 160 and the right tip 260 providing the grasping ends of the forceps. In this and other configurations, the surgical hand tool 100 can also include electrodes. For example, the surgical hand tool of Figures 1 and 2A can function as electrocautery bipolar forceps, as described further below. The surgical hand tool can further be configured to operate as scissors, which can also be referred to as the scissors configuration. Figure 4, described in more detail below, illustrates a scissors configuration where the tips 160, 260 slide and pivot relative to each other to cut tissue. The scissors can be utilized to more quickly cut tissue. The multiple configurations allow for the use of multiple surgical techniques at the discretion of the user. Other functional configurations are possible.

[0028] Referring now to Figures 2A-4, the hand tool 100 is designed to transition between the forceps configuration and the scissors configuration. The forceps configuration is shown in Figure 2A and the scissors configuration is shown in Figure 4. The intermediate configuration is shown in Figure 3. The hand tool 100 permits the switching between the forceps configuration and the scissors configuration. The hand tool 100 can transition between these configurations by rotation of the tips 160, 260 of the hand tool 100, as described further below. The tips 160, 260 are rotated approximately 90 degrees between the forceps configuration shown in Figure 2A and the scissors

configuration shown in Figure 4. The tips can be brought together as shown in Figure 3 during the transition between the forceps configuration and the scissors configuration.

COMPONENTS OF THE HAND TOOL

[0029] In some embodiments, the forceps configuration as shown in Figure 2A can operate as bipolar electrocautery forceps. For instance, the hand tool 100 can include one or more electrodes located on the tips of the hand tool. The hand tool 100 can be designed to supply electrical energy to the electrodes. In some embodiments, the hand tool 100 can optionally include an electrical connection 110. The electrical connection 110 can include a left lead 112 and a right lead 212. The electrical connection 110 can enable the electrodes to be supplied with electrical energy. In the illustrated configuration, the electrical connection 110 can be near the proximal end 116 of the hand tool 100.

[0030] In some embodiments, the hand tool 100 can include a mechanical connector 122. The mechanical connector 122 can function to electrically isolate the incoming electrical leads 112, 212. The mechanical connector 122 can function to couple the left section 102 and the right section 202.

[0031] The left lead 112 can include a receptacle 114. The receptacle 114 can be sized to accept the left spring 124. The left section 102 can include a left spring 124 that extends along the longitudinal axis 106. The left spring 124 can be coupled to the mechanical connector 122. In some embodiments, the left spring 124 can have an external shape that complements the shape of a receptacle 126 in the mechanical connector 122. In the illustrated embodiment, the shape of the left spring 124 is rectangular and the shape of the receptacles 126 is rectangular. Other shapes are contemplated (e.g., wedge, oval, triangular, elliptical, polygonal, etc.). The left spring 124 can be coupled to the mechanical connector 122 by welding, fasteners, glue, friction fit, pawl and ratchet, detent and protrusion, or other fixation method. The left spring 124 can be coupled to the left lead 112 of the electrical connection 110. In the illustrated embodiment, the left spring 124 is coupled to the left lead 112 within the mechanical connector 122. The left spring 124 can be coupled to the left lead 112 by welding, fasteners or other fixation method.

[0032] The left spring 124 can include a bend 128. The bend 128 can function to extend the distal end of the left spring 124 away from the longitudinal axis 106. The

bend 128 can function to curve the left spring 124 outward from the mechanical connector 122. The bend 128 of the left spring 124 can function to increase the distance between the left section 102 and the right section 202. The left spring 124 can include a concave portion. The concave portion can be near the proximal end of the left spring 124. The left spring 124 can include a convex portion. In the illustrated embodiment, the convex portion can be near the distal end of the left spring 124. The left spring 124 can include one or more flat portions 120, 130. In the illustrated embodiment, the flat portion 120 can be disposed within the receptacle 114. In other configurations the flat portion can be near the proximal end, distal end, or in between the proximal and distal end of the left spring 124. Other configuration of the spring can be contemplated (e.g., multiple bends, flat portions, multiple layers, thicknesses, varying thickness, height and length, etc.).

[0033] The distal end of the left spring 124 can be coupled to a left handle 132. In some embodiments, the left spring 124 can have an external shape that complements the shape of a receptacle 134 in the left handle 132. In the illustrated embodiment, the flat portion 130 can be disposed within the receptacle 134. In the illustrated embodiment, the shape of the left spring 124 is rectangular and the shape of the receptacle 134 is rectangular. Other configurations are contemplated (e.g., wedge, oval, triangular, elliptical, polygonal, etc.). The left spring 124 can be coupled to the left handle 132 by welding, fasteners, glue, friction fit, pawl and ratchet, detent and protrusion, or other fixation method. In the illustrated embodiment, the receptacle 134 is a slot that extends from the top of the left handle 132 to the bottom of the left handle 132, or a portion thereof. In some embodiments, the left spring 124 can be adjustable within the receptacle 134 of the left handle 132. In some embodiments, the left spring 124 can be adjusted to a number of discrete positions with the receptacle 134 (e.g., two, three, four, five, etc.). In some embodiments, the left spring 124 can be adjusted to an infinite number of positions with the receptacle 134. The left spring 124 can remain movable, releasably retained or fixedly retained in position.

[0034] The left handle 132 can include one or more finger grips 136 (see Figure 9A). In the illustrated embodiment, two finger grips 136 are shown. Other numbers of finger grips are contemplated (e.g., one, two, three, four, five, etc.). Both of the finger grips 136 are shown on the exterior surface of the left handle 132. Other locations are possible (e.g., top surface, bottom surface, interior surface, at least one grip

on the exterior surface, at least one grip on the top surface, a grip on the top surface and a grip on the exterior surface, etc.).

[0035] The left handle 132 can have a bayonet configuration. The left handle 132 can include a longitudinally extending portion 138 and a vertically extending portion 140. The longitudinally extending portion 138 can extend generally along the longitudinal axis 106. The vertically extending portion 140 can extend upward from the longitudinally extending portion 138. The vertically extending portion 140 can improve the line of sight for the user. The user's hand can engage the longitudinally extending portion 138. The vertically extending portion 140 can raise the distal end 118 of the hand tool 100 away from the user's hand. The user's hand does not obstruct the line of sight to the distal end 118 of the hand tool 100. In the illustrated embodiment, the vertically extending portion 140 forms an angle 142 with the longitudinally extending portion 138. The angle 142 can be 90° or greater than 90° (e.g., 100°, 110°, 120°, 130°, 140°, 150°, 160°, 170°, etc.). The angle 142 can be obtuse. Other configurations are possible. The angle 142 can provide a more ergonomic grip to the user.

[0036] The left section 102 can include a left hub 144. The left hub 144 can extend from the vertically extending portion 140. In some embodiments, the left hub 144 can be a unitary structure with the vertically extending portion 140 of the left handle 132. The left hub 144 and the left handle 132 can be monolithically formed.

[0037] In other embodiments, the left hub 144 is a separate component from the left handle 132. The vertically extending portion 140 can include a recess 146. The left hub 144 can be coupled to the recess 146 by welding, fasteners, glue, friction fit, pawl and ratchet, detent and protrusion, or other fixation method. In some embodiments, the left hub 144 is removable from the vertically extending portion 140. For instance, the left hub 144 can be removed to permit sterilization of the left tip 160. The left hub 144 can be removed to replace the left tip 160.

[0038] The left hub 144 can include a proximal portion 148. The proximal portion 148 of the left hub 144 can be received within the recess 146 of the vertically extending portion 140. The recess 146 can be shaped to complement the external surface of the proximal portion 148. The proximal portion 148 can be any cross-sectional shape including semi-circular, triangular, rectangular, etc. In some embodiments, the proximal portion 148 can extend the entire length of the vertically extending portion 140. The edge 150 of the proximal portion 148 can be angled to match the angle 142.

[0039] The left hub 144 can include a distal portion 152. The distal portion 152 can extend from the vertically extending portion 140. The distal portion 152 can extend from the recess 162 when proximal portion 148 is received within the recess 162. The edge 154 of the distal portion 152 can include a hub recess 156. The distal portion 152 can be a portion of a cylinder. The distal portion 152 can be any cross-sectional shape including semi-circular. In some embodiments, the proximal portion 148 and the distal portion 152 have the same cross-sectional shape. In other embodiments, the proximal portion 148 and the distal portion 152 have different cross-sectional shapes. In some embodiments, the proximal portion 148 and the distal portion 152 can have the same diameter. In other embodiments, the proximal portion 148 and the distal portion 152 have different diameters.

[0040] The left hub 144 can define a left tip axis 158. The left tip axis 158 can be the axis upon which the left tip 160 rotates. The distal portion 152 of the left hub 144 can function to support the left tip 160 during rotation. The hub recess 156 can be aligned with the left tip axis 158. The hub recess 156 can function to maintain alignment of the left tip 160 during rotation. In some methods of assembly, the left hub 144 is coupled to the vertically extending portion 140. This can create a channel between the external surface of the left hub 144 and the internal surface of the recess 162. A portion of the left tip 160 can rotate within this channel.

[0041] The left tip 160 can include a proximal portion 164. The proximal portion 164 of the left tip 160 can be supported by the left hub 144. The proximal portion 164 of the left tip 160 can rotate about the left hub 144. At least a portion of the proximal portion 164 of the left tip 160 can be received within the recess 162 of the vertically extending portion 140.

[0042] In the illustrated embodiment, the recess 162 of the vertically extending portion 140 can include a first portion 166 and a second portion 168. The first portion 166 can have a circular cross-section and the second portion 168 can have a circular cross-section. The first portion 166 can have a semi-circular cross-section and the second portion 168 can have a semi-circular cross-section. The cross-sectional shapes of the first portion 166 and the second portion 168 can permit rotation of the left tip 160 within the recess 162.

[0043] The first portion 166 can have a first diameter and the second portion 168 can have a second diameter. The first diameter can be smaller than the second

diameter. The first portion 166 can be located distal to the second portion 168. The first portion 166 of the recess 162 can be closer to the distal end 118. The second portion 168 can be located proximal to the first portion 166. The second portion 168 of the recess 162 can be closer to the proximal end 116. The difference in diameter between the first portion 166 and the second portion 168 of the recess 162 can create a lip.

[0044] The recess 162 can have any number of portions (e.g., two, three, four, five, six, etc.). Each portion can have a diameter that is either the same or different than one or more other portions. At least two of the portions have unequal diameters. Of the at least two portions, a portion near the distal end can have a smaller diameter than another portion near the proximal end. The difference in diameter between the portions of the recess 162 can create a lip.

[0045] In the illustrated embodiment, the left tip 160 can include a ridge 174 which can interact with the lip. The ridge 174 can extend from the external surface of the proximal portion 164 of the left tip 160. The ridge 174 can be sized to be received within the second portion 168 of the recess 162. For instance, the ridge 174 and the second portion 168 can have the same or similar diameter. The ridge 174 can have a larger diameter than the first portion 166. The ridge 174 can abut the lip created by the first portion 166 and the second portion 168. The ridge 174 can reduce axial translation of the left tip 160 when the left tip 160 is received within the recess 162. The ridge 174 can reduce the longitudinal movement of the left tip 160 when the ridge 174 is received within the recess 162. The ridge 174 can prevent disengagement between the vertically extending portion 140 and the left tip 160 by the application of axial force.

[0046] The proximal portion 164 of left tip 160 can include a left extension 178 which can interact with the hub 144. The left extension 178 can be a portion of a cylinder. In some embodiments, the left extension 178 can have a quarter-circular cross-section (e.g., encompasses 90 degrees). The left extension 178 can have a convex external surface. The convex external surface can be complementary to the second portion 168. The left extension 178 can have a concave internal surface 180. The concave internal surface 180 can be complementary to the external surface of the distal portion 152 of the left hub 144.

[0047] The proximal portion 164 of left tip 160 can include a protrusion 172 which can interact with the hub recess 156. The protrusion 172 is sized to be received within the hub recess 156. For instance, the protrusion 172 and the hub recess 156 can

have the same or similar diameter. The protrusion 172 can extend along the left tip axis 158 when the ridge 174 is received within the recess 162. The protrusion 172 and the hub recess 156 can provide a pivot for the left tip 160 as the left tip 160 rotates.

[0048] The left tip 160 can include a distal portion 170. The distal portion 170 of the left tip 160 can include a longitudinally extending portion 182. The longitudinally extending portion 182 can be a portion of a cylinder. In some embodiments, the longitudinally extending portion 182 can have a semi-circular cross-section (e.g., encompasses 180 degrees). The longitudinally extending portion 182 can have a convex external surface. The distal 170 and longitudinally extending 182 portions can have other cross-sectional shapes (e.g., circular, elliptical, square, rectangular, triangular, polygonal, sigmoid, etc.).

[0049] The distal portion 170 of the left tip 160 can include a conical portion 186. The conical portion 186 can extend to a distal tip 188. The conical portion 186 and distal tip 188 can interact with the right section 202 to function as forceps. The conical portion 186 can include a cutting edge 190. The cutting edge 190 can interact with the right section 202 to function as scissors. The cutting edge 190 can be the same material as the distal portion 170 of the left tip 160. The cutting edge 190 can be the same material as the left tip 160. The cutting edge 190 can be a different material than the distal portion 170 of the left tip 160. The cutting edge 190 can be a different material than the left tip 160. The cutting edge 190 can be integrally or monolithically formed with the left tip 160. The cutting edge 190 can be a separate component and coupled to the left tip 160.

[0050] The distal portion 170 of the left tip 160 can have a flat internal surface 184. The flat internal surface 184 can be complementary to an internal surface of the right section 202. The flat internal surface 184 can extend the length of the longitudinally extending portion 182. The flat internal surface 184 can extend the length of the conical portion 186. The flat internal surface 184 can abut a flat internal surface of the right tip. Other cross-sectional shapes of the internal surface can be contemplated (e.g., circular, elliptical, square, rectangular, triangular, polygonal, sigmoid etc.). These can be complimentary, mirror or rotationally similar to the right tip 260.

[0051] The distal portion 170 of the left tip 160 can include an electrode 192. In some embodiments, the longitudinally extending portion 182 can include the electrode 192. In some embodiments, the conical portion 186 can include the electrode 192. In some embodiments, the distal tip 188 can include the electrode 192. In some

embodiments, the flat internal surface 184 can include the electrode 192. In some embodiments, the external surface of the left tip 160 can include the electrode 192. The electrode 192 can interact with the right section 202. The right section 202 can include a ground or another electrode. The left tip 160 can interact with the right section to function as an electrosurgical device. The electrode 192 can be activated by electrical energy supplied to the hand tool 100. The electrode 192 can be activated when the hand tool 100 is in the forceps configuration. In some embodiments, electrical energy is prevented from being supplied when the hand tool 100 is in the scissors configuration. The electrode 192 can be the same material as the distal portion 170 of the left tip 160. The electrode 192 can be the same material as the left tip 160. The electrode 192 can be a different material than the distal portion 170 of the left tip 160. The electrode 192 can be a different material than the left tip 160. The electrode 192 can be integrally or monolithically formed with the left tip 160. The electrode 192 can be a separate component and coupled to the left tip 160.

[0052] In some embodiments, the left lead 112 can pass through a channel in the left spring 124. The left lead 112 can pass through a channel in the left handle 132. The left lead 112 can pass through a channel in the left tip 160. The channels in any of the components in the left section 102 can be insulated.

[0053] In some methods of assembly, the left tip 160 is inserted within the recess 162. Then the left hub 144 is coupled to the vertically extending portion 140. The left tip 160 is placed in the recess prior to coupling of the left hub 144. The left tip 160 can be retained within the recess 162 by a retention mechanism (not shown). In some embodiments, the left hub 144 is removable. The left hub 144 can be removed to replace the left tip 160. The left hub 144 can be removed to sterilize or replace the left tip 160.

[0054] In some embodiments, the left hub 144 is integrally formed with the vertically extending portion 140. Then the left tip 160 is inserted within the recess 162. The ridge 174 is aligned with the second portion 168 of the recess 162 in the vertically extending portion 140. The internal surface 180 of the left extension 178 is aligned with the external surface of the left hub 144. The protrusion 172 of the left tip 160 is aligned with the hub recess 146. From this position, the left tip 160 can be rotated about the left tip axis 158. The left tip 160 can be rotated until the ridge 174 is received within the second portion 168 of the recess 162. In this position, the internal surface 180 of the left

extension 178 can be in contact with the external surface of the left hub 144. In this position, protrusion 172 can be received within the hub recess 146.

[0055] In some embodiments, the left section 102 and the right section 202 each form of a symmetrical, opposed half. The right section 202 can be a mirror image of the left section 102. The right section 202 can include substantially similar or identical components. In some embodiments, the right section 202 may have a different shape or configuration to enhance ergonomics for the user.

[0056] The right lead 212 can include a receptacle 214. The receptacle 214 can be sized to accept the right spring 224. The right section 202 can include a right spring 224 that extends along the longitudinal axis 106. The right spring 224 can be coupled to the mechanical connector 122. In some embodiments, the right spring 224 can have an external shape that complements the shape of a receptacle 226 in the mechanical connector 122. In the illustrated embodiment, the shape of the right spring 224 is rectangular and the shape of the receptacles 226 is rectangular. Other configurations are contemplated (e.g., wedge, oval, triangular, elliptical, polygonal, etc.). The right spring 224 can be coupled to the mechanical connector 122 by welding, fasteners, glue, friction fit, pawl and ratchet, detent and protrusion, or other fixation method. The right spring 224 can be coupled to the right lead 212 of the electrical connection 110. In the illustrated embodiment, the right spring 224 is coupled to the right lead 212 within the mechanical connector 122. The right spring 224 can be coupled to the right lead 212 by welding, fasteners or other fixation method.

[0057] The right spring 224 can include a bend 228. The bend 228 can function to extend the distal end of the right spring 224 away from the longitudinal axis 106. The bend 228 can function to curve the right spring 224 outward from the mechanical connector 122. The bend 228 of the right spring 224 can function to increase the distance between the left section 102 and the right section 202. The right spring 224 can include a concave portion. The concave portion can be near the proximal end of the right spring 224. The right spring 224 can include a convex portion. In the illustrated embodiment, the convex portion can be near the distal end of the right spring 224. The right spring 224 can include one or more flat portions 220, 230. In the illustrated embodiment the flat portion 220 can be disposed within the receptacle 214. In other configurations the flat portion can be near the proximal end, distal end, or in between the proximal and distal end of the right spring 224. The right spring 224 can provide the

same or different resistance as the left spring 124. The right spring 224 can provide the same or different shape as the left spring 124. The right spring 224 can be a mirror image of the left spring 124.

[0058] The distal end of the right spring 224 can be coupled to a right handle 232. In some embodiments, the right spring 224 can have an external shape that complements the shape of a receptacle 234 in the right handle 232. In the illustrated embodiment the flat portion 230 can be disposed within the receptacle 234. In the illustrated embodiment, the shape of the right spring 224 is rectangular and the shape of the receptacle 234 is rectangular. Other configurations are contemplated (e.g., wedge, oval, triangular, elliptical, polygonal, etc.). In the illustrated embodiment, the receptacle 234 is a slot that extends from the top of the right handle 232 to the bottom of the right handle 232, or a portion thereof. In some embodiments, the right spring 224 is coupled to the right handle 232 by welding, fasteners, glue, friction fit, pawl and ratchet, detent and protrusion, or other fixation method. In some embodiments, the right spring 224 is adjustable within the receptacle 234 of the right handle 232. In some embodiments, the right spring 224 can be adjusted to a number of discrete positions with the receptacle 234 (e.g., two, three, four, five, etc.). In some embodiments, the right spring 224 can be adjusted to an infinite number of positions with the receptacle 234. The right spring 224 can remain movable, releasably retained or fixedly retained in position. In some embodiments, the right spring 224 is movable and the left spring 124 is fixed. At least one spring 124, 224 can be movable to accommodate the user's hand. In some embodiments, both springs 124, 224 are movable to accommodate the user's hand.

[0059] The right handle 232 can include one or more finger grips 236. In the illustrated embodiment, two finger grips 236 are shown but other configurations are contemplated (e.g., one, two, three, four, five, etc.). Both of the finger grips 236 are shown on the exterior surface of the right handle 232. Other locations are possible (e.g., top surface, bottom surface, interior surface, at least one grip on the exterior surface, at least one grip on the top surface, a grip on the top surface and a grip on the exterior surface, etc.). The finger grips 236 can have the same or different configuration as the finger grips 136. For instance, one set of finger grips can be shaped for the index finger and the other set of grips can be shaped for the thumb. The finger grips 136, 236 can be positioned based on the manner in which the user is expected to hold the hand tool 100. The finger grips 136, 236 can be positioned based on right handed use. The finger grips

136, 236 can be positioned based on left handed use. The finger grips 136, 236 can be positioned based on ambidextrous use.

[0060] The right handle 232 can have a bayonet configuration. The right handle 232 can include a longitudinally extending portion 238 and a vertically extending portion 240. The longitudinally extending portion 238 can extend generally along the longitudinal axis 106. The vertically extending portion 240 can extend upward from the longitudinally extending portion 238. The vertically extending portion 240 can improve the line of sight for the user. The user's hand can engage the longitudinally extending portion 238. The vertically extending portion 240 can raise the distal end 118 of the hand tool 100 away from the user's hand. The user's hand does not obstruct the line of sight to the distal end 118 of the hand tool 100. In the illustrated embodiment, the vertically extending portion 240 forms an angle 242 with the longitudinally extending portion 238. The angle 242 can be 90° or greater than 90° (e.g., 100°, 110°, 120°, 130°, 140°, 150°, 160°, 170°, etc.). The angle 242 can be obtuse. The angle 242 can be the same as angle 142. In other embodiments, the angle 242 is different than angle 142 based on the manner in which the user is expected to hold the hand tool 100. The angle 242 can be selected to better complement the grip of the user (e.g., based on the anatomy of the human hand). Other configurations are possible.

[0061] The right section 202 can include a right hub 244. The right hub 244 can extend from the vertically extending portion 240. In some embodiments, the right hub 244 can be a unitary structure with the vertically extending portion 240 of the right handle 234. The right hub 244 and the right handle 232 can be monolithically formed.

[0062] In other embodiments, the right hub 244 is a separate component from the right handle 232. The vertically extending portion 240 can include a recess 246. The right hub 244 can be coupled to the recess 246 by welding, fasteners, glue, friction fit, pawl and ratchet, detent and protrusion, or other fixation method. In some embodiments, the right hub 244 is removable from the vertically extending portion 240. For instance, the right hub 244 can be removed to permit sterilization of the right tip 260. The right hub 244 can be removed to replace the right tip 260.

[0063] The right hub 244 can include a proximal portion 248. The proximal portion 248 of the right hub 244 can be received within the recess 246 of the vertically extending portion 240. The recess 246 can be shaped to complement the external surface of the right hub 244. The proximal portion 248 of the right hub 244 can be any cross-

sectional shape including semi-circular, triangular, rectangular, etc. In some embodiments, the proximal portion 248 can extend the entire length of the vertically extending portion 240. The edge 250 of the proximal portion 248 can be angled to match the angle 242.

[0064] The right hub 244 can include a distal portion 252. The distal portion 252 can extend from the vertically extending portion 240. The distal portion 252 can extend from the recess 262 when proximal portion 248 is received within the recess 262. The edge 254 of the distal portion 252 can include a hub recess 256. The distal portion 252 can be a portion of a cylinder. The distal portion 252 can be any cross-sectional shape including semi-circular. In some embodiments, the proximal portion 248 and the distal portion 252 have the same cross-sectional shape. In other embodiments, the proximal portion 248 and the distal portion 252 have different cross-sectional shapes. In some embodiments, the proximal portion 248 and the distal portion 252 can have the same diameter. In other embodiments, the proximal portion 248 and the distal portion 252 have different diameters.

[0065] The right hub 244 can define a right tip axis 258. The right tip axis 258 can be the axis upon which the right tip 260 rotates. The distal portion 252 of the right hub 244 can function to support the right tip 260 during rotation. The hub recess 256 can be aligned with the right tip axis 258. The hub recess 256 can function to maintain alignment of the right tip 260 during rotation. In some methods of assembly, the right hub 244 is coupled to the vertically extending portion 240. This can create a channel between the external surface of the right tip 260 and the internal surface of the recess 262. A portion of the right tip 260 can rotate within this channel.

[0066] The right tip 260 can include a proximal portion 264. The proximal portion 264 of the right tip 260 can be supported by the right hub 244. The proximal portion 264 of the right tip 260 can rotate about the right hub 244. At least a portion of the proximal portion 264 of the right tip 260 can be received within the recess 262 of the vertically extending portion 240.

[0067] In the illustrated embodiment, the recess 262 of the vertically extending portion 240 can include a first portion 266 and a second portion 268 (not shown). The first portion 266 can be similar or a mirror image of first portion 166. The second portion 268 can be similar or a mirror image of second portion 168. The first portion 266 can have a circular cross-section and the second portion 268 can have a

circular cross-section. The first portion 266 can have a semi-circular cross-section and the second portion 268 can have a semi-circular cross-section. The cross-sectional shapes of the first portion 266 and the second portion 268 can permit free rotation of the right tip 260 within the recess 262.

[0068] The first portion 266 can have a first diameter and the second portion 268 can have a second diameter. The first diameter can be smaller than the second diameter. The first portion 266 can be located distal to the second portion 268. The first portion 266 of the recess 262 can be closer to the distal end 118. The second portion 268 can be located proximal to the first portion 266. The second portion 268 of the recess 262 can be closer to the proximal end 116. The difference in diameter between the first portion 266 and the second portion 268 of the recess 262 can create a lip.

[0069] The recess 262 can have any number of portions (e.g., two, three, four, five, six, etc.). Each portion can have a diameter that is either the same or different than one or more other portions. At least two of the portions have unequal diameters. Of the at least two portions, a portion near the distal end can have a smaller diameter than another portion near the proximal end. The difference in diameter between the portions of the recess 262 can create a lip.

[0070] In the illustrated embodiment, the right tip 260 can include a ridge 274 which can interact with the lip. The ridge 274 can extend from the external surface of the proximal portion 264 of the right tip 260. The ridge 274 can be sized to be received within the second portion 268 of the recess 262. For instance, the ridge 274 and the second portion 268 can have the same or similar diameter. The ridge 274 can have a larger diameter than the first portion 266. The ridge 274 can abut the lip created by the first portion 266 and the second portion 268. The ridge 274 can reduce axial translation of the right tip 260 when the right tip 260 is received within the recess 262. The ridge 274 can reduce the longitudinal movement of the right tip 260 when the ridge 274 is received within the recess 262. The ridge 274 can prevent disengagement between the vertically extending portion 240 and the right tip 260 by the application of axial force.

[0071] The proximal portion 164 of right tip 260 can include a right extension 278 which can interact with the hub 244. The right extension 278 can be a portion of a cylinder. In some embodiments, the right extension 278 can have a quarter-circular cross-section (e.g., encompasses 90 degrees). The right extension 278 can have a convex external surface. The convex external surface can be complementary to the second

portion 268. The right extension 278 can have a concave internal surface 280. The concave internal surface 280 can be complementary to the external surface of the distal portion 252 of the right hub 244.

[0072] The proximal portion 264 of right tip 260 can include a protrusion 272 which can interact with the hub recess 256. The protrusion 272 is sized to be received within the hub recess 256. For instance, the protrusion 272 and the hub recess 256 can have the same or similar diameter. The protrusion 272 can extend along the right tip axis 258 when the ridge 274 is received within the recess 262. The protrusion 272 and the hub recess 256 can provide a pivot for the right tip 260 as the right tip 260 rotates.

[0073] The right tip 260 can include a distal portion 270. The distal portion 270 of the right tip 260 can include a longitudinally extending portion 282. The longitudinally extending portion 282 can be a portion of a cylinder. In some embodiments, the longitudinally extending portion 182 can have a semi-circular cross-section (e.g., encompasses 180 degrees). The longitudinally extending portion 282 can have a convex external surface. The distal 270 and longitudinally extending 282 portions can have other cross-sectional shapes (e.g., circular, elliptical, square, rectangular, triangular, polygonal, sigmoid, etc.).

[0074] The distal portion 270 of the right tip 260 can include a conical portion 286. The conical portion 286 can extend to a distal tip 288. The distal tip 288 can interact with the left section 102 to function as forceps. The conical portion 286 can include a cutting edge 290. The cutting edge 290 can interact with the left section 102 to function as scissors. The cutting edge 290 can be the same material as the distal portion 270 of the right tip 260. The cutting edge 290 can be the same material as the right tip 260. The cutting edge 290 can be a different material than the distal portion 270 of the right tip 260. The cutting edge 290 can be a different material than the right tip 260. The cutting edge 290 can be integrally or monolithically formed with the right tip 260. The cutting edge 290 can be a separate component and coupled to the right tip 260.

[0075] The distal portion 270 of the right tip 260 can have a flat internal surface 284. The flat internal surface 284 can be complementary to an internal surface of the left section 102. The flat internal surface 284 can extend the length of the longitudinally extending portion 282. The flat internal surface 284 can extend the length of the conical portion 286. The flat internal surface 284 can abut a flat internal surface of the left tip 160. Other cross-sectional shapes of the internal surface can be contemplated

(e.g., circular, elliptical, square, rectangular, triangular, polygonal, sigmoid, etc.). These can be complimentary, mirror or rotationally similar to the right tip 160. [0075] The distal portion 270 of the right tip 260 can include an electrode 292. In some embodiments, the longitudinally extending portion 282 can include the electrode 292. In some embodiments, the conical portion 286 can include the electrode 292. In some embodiments, the distal tip 288 can include the electrode 292. In some embodiments, the flat internal surface 284 can include the electrode 292. In some embodiments, the external surface of the right tip 260 can include the electrode 292. The electrode 292 can interact with the left section 102. The left section 102 can include a ground or another electrode. The right tip 260 can interact with the left section 102 function as an electrosurgical device. The electrode 292 can be activated by electrical energy supplied to the hand tool 100. The electrode 292 can be activated when the hand tool 100 is in the forceps configuration. In some embodiments, electrical energy is prevented from being supplied when the hand tool 100 is in the scissors configuration. The electrode 292 can be the same material as the distal portion 270 of the right tip 260. The electrode 292 can be the same material as the right tip 260. The electrode 292 can be a different material than the distal portion 270 of the right tip 260. The electrode 292 can be a different material than the right tip 260. The electrode 292 can be integrally or monolithically formed with the right tip 260. The electrode 292 can be a separate component and coupled to the right tip 260.

[0076] In some embodiments, the right lead 212 can pass through a channel in the right spring 224. The right lead 212 can pass through a channel in the right handle 232. The right lead 212 can pass through a channel in the right tip 260. The channels in any of the components in the right section 202 can be insulated.

[0077] In some methods of assembly, the right tip 260 is inserted within the recess 262. Then the right hub 244 is coupled to the vertically extending portion 240. The right tip 260 is placed in the recess 262 prior to coupling of the right hub 244. The right tip 260 can be retained within the recess 262 by a retention mechanism (not shown). In some embodiments, the right hub 244 is removable. The right hub 244 can be removed to replace the right tip 260. The right hub 244 can be removed to sterilize the right tip 260.

[0078] In some methods of assembly, the right hub 244 is coupled to the vertically extending portion 240. This creates a channel between the external surface of the right hub 244 and the internal surface of the recess 262. In some embodiments, the

right hub 244 is integrally formed with the vertically extending portion 240. Then the right tip 260 is inserted within the recess 262. The ridge 274 is aligned with the second portion 268 the recess 262 in the vertically extending portion 240. The internal surface 280 of the right extension 278 is aligned with the external surface of the right hub 244. The protrusion 272 of the right tip 260 is aligned with the hub recess 246.

[0079] From this position, the right tip 260 can be rotated about the right tip axis 258. The right tip 260 can be rotated until the ridge 274 is received within the second portion 268 of the recess 162. In this position, the internal surface 280 of the right extension 278 can be in contact with the external surface of the right hub 244. In this position, the protrusion 272 can be received within the hub recess 256.

[0080] As shown in Figure 1, the hand tool 100 can include a pin 296 coupled to a portion of the right tip 260. The pin 296 can be positioned on the right extension 278. The pin 296 can extend from an external surface of the right extension 278. The pin 296 can extend radially outward from the outer surface of the right extension 278. In the illustrated embodiment, the pin 296 extends at an angle to the right tip axis 158. The angle may be substantially perpendicular or perpendicular. The pin 296 can extend transverse to the right tip axis 258.

[0081] The pin 296 can be a separate component coupled to the right tip 260. The pin 296 can be coupled by welding, fasteners, glue, friction fit, pawl and ratchet, detent and protrusion, or other fixation method. The pin 296 can be integrally or monolithically formed with the right tip 260. The pin 296 can interact with a mechanism 300, as discussed in greater detail below.

[0082] In an alternative embodiment, a pin can be coupled to a portion of the left tip 160 rather than the right tip 260. The pin can be a mirror image of the pin 296. The pin can be positioned on the left extension 178. The pin can extend from an external surface of the left extension 178. The pin can extend radially outward from the outer surface of the left extension 178. The pin 296 can be positioned on either extension 178, 278. The pin 296 can be positioned on either tip 160, 260.

[0083] In some embodiments, one of the tips 160, 260 can have a protrusion 294 and the other tip can have a recess 194. Referring to Figures 2B, 7C, and 8C, the left tip 160 can have the recess 194 and the right tip 260 can have the protrusion 294. In other embodiments, the left tip 160 can have the protrusion 294 and the right tip 260 can have the recess 194. The protrusion 294 can extend perpendicularly from the flat internal

surface 284 of the right tip 260. The protrusion 294 can be located near the longitudinally extending portion 282 or the conical portion 286 of the right tip 260. The recess 194 can extend perpendicularly from the flat internal surface 184 of the left tip 160. The recess 194 can be located near the longitudinally extending portion 182 or the conical portion 186 of the left tip 160. The protrusion 294 and the recess 194 can be located near the distal end 118 of the hand tool 100.

[0084] The protrusion 294 can be sized to fit within the recess 194. The protrusion 294 or the recess 194 can include features to facilitate insertion of the protrusion 294 within the recess 194. In some embodiments, the edges of the protrusion 294 are rounded to facilitate insertion. The protrusion 294 can provide a pivot for the tips 160, 260 to rotate relative to each other. The protrusion 294 and the recess 194 can provide an axis 198 upon which the tips 160, 260 can pivot relative to each other. The protrusion 294 can engage the recess 194 when the hand tool 100 is in the scissor configuration. The protrusion 294 can engage the recess 194 when the hand tool 100 is in the intermediate configuration.

[0085] Each tip 160, 260 can include a cutting edge 190, 290. The cutting edges 190, 290 can be located on the conical portions 186, 286. The cutting edges 190, 290 can be located on the longitudinally extending portions 182, 282. Each tip 160, 260 can include one cutting edge, similar to a pair of scissors. The cutting edges 190, 290 can have a range of motion from a closed position to an open position. In some embodiments, the angle formed between the cutting edges 190, 290 is ninety degrees in the open position. When the cutting edges 190, 290 are being closed, the cutting edges 190, 290 can shear relative to each other. This action can cut tissue. In some embodiments, each tip 160, 260 can include two or more cutting edges.

[0086] The springs 124, 224 can be designed to return each handle 132, 232 to a neutral position. In some embodiments, the neutral position can include a separation between the conical portions 186, 286. In some embodiments, the neutral position can include a separation between the longitudinally extending portions 182, 282. In some embodiments, the neutral position can include a separation between the handles 132, 232. In other configurations, the hand tool 100 can include one spring (e.g., either the left spring 124 or the right spring 224). For instance, the hand tool 100 can include the right spring 224. The longitudinally extending portion 128 of the left handle 132 can extend to

the mechanical connector 122. The right handle 232 can be manipulated to move the right tip 260 relative to the left tip 160.

[0087] In some embodiments, the longitudinally extending portions 128, 228 are curved or substantially curved (e.g., concave, convex, bent, etc.). In other configurations, the longitudinally extending portions 128, 228 are straight or substantially straight. In some embodiments, the conical portions 186, 286 are curved or substantially curved (e.g., concave, convex, bent, etc.). In other configurations, the conical portions 186, 286 are straight or substantially straight.

[0088] In some embodiments, the handles 132, 232 of the hand tool 100 can extend substantially along the longitudinal axis 106. The recesses 162, 262 can extend along the longitudinal axis 106. The handles 132, 232 can have any cross-sectional shape including rectangular, square, polygonal, etc. In some embodiments, the handles 132, 232 are straight or substantially straight. In some embodiments, the handles 132, 232 are curved or substantially curved (e.g., concave, convex, bent, etc.).

[0089] In some embodiments, electrical energy is supplied at a location along the length of the hand tool 100. For instance, electrical energy can be supplied to each handle 132, 232 of hand tool 100. The lead 112 can be coupled to the left handle 132 and the lead 212 can be coupled to the right handle 232. The distance between the handles 132, 232 can function as an electrical isolator. For instance, electrical energy can be supplied to each hub 144, 244 of hand tool 100. The lead 112 can be coupled to the left hub 144 and the lead 212 can be coupled to the right hub 244. The distance between the hubs 144, 244 can function as an electrical isolator. For instance, electrical energy can be supplied to each tip 160, 260 of hand tool 100. The lead 112 can be coupled to the left tip 160 and the lead 212 can be coupled to the right tip 260. The distance between the tips 160, 260 can function as an electrical isolator.

[0090] Each tip 160, 260 can include electrode 192, 292 for bipolar electrocautery. The electrodes 192, 292 can be located on the longitudinally extending portion 182, 282. The electrodes 192, 292 can be located on the conical portion 186, 286. The electrodes 192, 292 can be located on an external surface of the tips 160, 260. The electrodes 192, 292 can be located on an internal surface of the tips 160, 260 for instance the flat surfaces 184, 284. The electrodes 192, 292 can be configured for cauterization, hemostasis, and tissue dissection.

[0091] The hand tool 100 can allow current to flow from the location where electrical energy is supplied to the electrodes 192, 292. The hand tool 100 can have a current passage that allows current to flow through the hand tool 100 and to the electrodes 192, 292. The hand tool 100 can be sufficiently insulated to prevent the dissipation of electrical energy. The hand tool 100 can be grounded. The hand tool 100 can be designed to operate in conjunction with currently available current generators.

[0092] The hand tool 100 can have a fluid passage having a fluid inlet and a fluid outlet. The fluid inlet can be located near a proximal end 116 of the hand tool 100. The fluid inlet can be connectable to a fluid source. The fluid outlet can be located near the distal end 118 of the hand tool 100. In some embodiments, the hand tool 100 can have more than one fluid outlet. The fluid outlet can be in fluid communication with the fluid inlet, such that fluid can travel through the fluid passage of the hand tool 100. The fluid outlet can be located on the longitudinally extending portion 182, 282. The fluid outlet can be located on the conical portion 186, 286. The fluid outlet can be located on an external surface of the tips 160, 260. The fluid outlet can be located on an internal surface of the tips 160, 260, for instance the flat surfaces 184, 284. The fluid outlet can be located near the electrodes 192, 292. The fluid can be a coolant, a medication, or any substance selected to be delivered to the surgical site. The hand tool 100 can be designed to operate in conjunction with currently available fluid systems.

OPERATION OF THE HAND TOOL

[0093] The hand tool 100 can transition between at least two functional configurations, as shown generally in Figures 2A and 4. These configurations are referred to as the forceps configuration and the scissors configuration. In some embodiments, the forceps configuration includes a bipolar electrocautery forceps configuration. In some embodiments, the scissors configuration includes a microscissors configuration. In some embodiments, the scissors configuration and the forceps configuration are mutually exclusive functional configurations.

[0094] Figure 2A shows the hand tool 100 in the forceps configuration. The springs 124, 224 bias the handles 132, 232 away from each other. The distal tips 188, 288 can be separated in the neutral position. The user can apply a force to the handles 132, 232 to move the distal tips 188, 288 toward each other. The user can release the force to the handles 132, 232 and the distal tips 188, 288 can return to the neutral position.

[0095] Figure 3 shows the hand tool 100 in the intermediate configuration. In order to change configurations, the handles 132, 232 are moved toward each other. The user applies a force to overcome the biasing force of the springs 124, 224. The internal surface of the handles 132, 232 can abut. The left tip 160 and the right tip 260 can be brought together. The tips 160, 260 can abut. The internal flat surfaces 184, 284 can abut. The left tip axis 158 and the right tip axis 258 can align along the longitudinal axis 106. The protrusion 294 can engage the recess 194. The intermediate configuration permits the transition from the forceps configuration to the scissors configuration. The intermediate configuration permits the transition from the scissors configuration to the forceps configuration.

[0096] Figure 4 shows the hand tool 100 in the scissors configuration. The springs 124, 224 bias the handles 132, 232 away from each other. The distal tips 188, 288 can be separated in the neutral position. The user can apply a force to the handles 132, 232 to move the distal tips 188, 288 toward each other. The user can apply a force to the handles 132, 232 to pivot the distal tips 188, 288 about the axis 198. The user can apply a force to the handles 132, 232 to shear the cutting edges 190, 290 past each other. The user can release the force to the handles 132, 232 and the distal tips 188, 288 can return to the neutral position.

[0097] In both the forceps and the scissors configuration, the proximal portion 164 of the left tip 160 is retained within the recess 162. In both the forceps and the scissors configuration, the proximal portion 264 of the right tip 260 is retained within the recess 262. In both the forceps and the scissors configuration, the ridge 174 is retained within the recess 162. In both the forceps and the scissors configuration, the ridge 274 is retained within the recess 262.

[0098] In the forceps configuration, the internal flat surfaces 184, 284 are vertical or substantially vertical. In the scissors configuration, the internal flat surfaces 184, 284 are horizontal or substantially horizontal. In the forceps configuration, the right tip 260 can be horizontally offset from the left tip 160. The right tip 260 can be toward the right and the left tip 160 can be toward the left. In the scissors configuration, the right tip 260 can be generally over top the left tip 160. In the scissors configuration, the left tip 160 can be generally underneath the right tip 260.

[0099] As shown in Figures 1-4, the hand tool 100 can include a mechanism 300 that enables the user to transition between the forceps configuration and the scissors

configuration. In the illustrated embodiment, the mechanism 300 is located on the right handle 232. The mechanism 300 can interact with the pin 296. The mechanism 300 can be located as part of the same section as the pin 296. In the illustrated embodiment, the pin 296 is located on the right section 202. In the illustrated embodiment, the mechanism 300 is located on the right section 202.

[0100] The mechanism 300 can include a slide 302. The slide 302 can be coupled to the vertically extending portion 240. In the illustrated embodiment, the vertically extending portion 140 can include a retaining hole 298. The slide 302 can include a guide slot 310. The guide slot 310 can engage the retaining hole 298. For instance, the retaining hole 270 can engage a screw (not shown). The screw can translate within the guide slot 310 when the slide 302 translates. In some embodiments, the slide 302 can be coupled via a rail, protrusion, detent, ratchet, etc. The slide 302 is designed to translate along a portion of the vertically extending portion 240. The slide 302 is capable of sliding upward and downward relative to the right handle 232. The slide 302 can be less than the total height of the vertically extending portion 240 or a percentage of the total height (e.g., 20%, 30%, 40%, 50%, 60%, 70%, 80%, 90%, etc.). The slide 302 can be less than the total width of the vertically extending portion 240 or a percentage of the total width (e.g., 20%, 30%, 40%, 50%, 60%, 70%, 80%, 90%, etc.). The slide 302 can be greater than the total width of the vertically extending portion 240 (e.g., 110%, 120%, 130%, 140%, 150%, 160%, 170%, 180%, 190%, 200%, 300% etc.).

[0101] The slide 302 can include a lower portion 304 and an upper portion 306. The lower portion 304 can be approximately the same length as the vertically extending portion 240. The upper portion 306 can be a greater length than the vertically extending portion 240. The upper portion 306 can extend distally from the vertically extending portion 240 near the upper edge of the slide 302. In some embodiments, the upper portion 306 can include a housing 308. The housing 308 can extend distally from the vertically extending portion 240 near the upper edge of the slide 302. The housing 308 can have a greater width than the width of the lower portion 304. The housing 308 can be convex. The housing 308 can have a non-symmetrical shape. In the illustrated embodiment, the slide 302 can include at least a portion that extends distally from the vertically extending portion 240. The housing 308 can include any shape (e.g., circular, elliptical, square, rectangular, triangular, polygonal, sigmoid, etc.).

[0102] The mechanism 300 can include a grip 312. The grip 312 can be located near an edge of the slide 302. The grip 312 can be located proximally from the vertically extending portion 240. In the illustrated embodiment, the grip 312 is located near the proximal end of the slide 302. Other configurations are contemplated (e.g., near the top of the slide 302, near the bottom of the slide 302, on an external surface of the slide 302, etc.). The grip 312 can include one or more ridges to facilitate the movement of the slide 302. Other configurations are contemplated (e.g., roughened surfaces, protrusions, etc.).

[0103] The mechanism 300 can include a slot 314. The slot 314 provides a path for the pin 296 as the slide 302 is translated. The slot 314 can be within the housing 308. The outer perimeter of the slot 314 can be within or smaller than the outer perimeter of the housing 308. The housing 308 can have a width sufficient to enclose the pin 296. The housing 308 can have an area of increased thickness near the slot 314. The increased thickness can facilitate repeated movements against the pin 296 without deformation of the housing 308. In some embodiments, the slot 314 is covered. The slot 314 can be covered by an external surface of the housing 308. In other embodiments, the slot 314 is exposed to the user.

[0104] In some embodiments, the slot 314 is linear. In other embodiments, the slot 314 is non-linear. The slot 314 can have a variety of shapes including curved, s-shaped, bow-tie shaped, sloped, stepped, etc. The slot 314 can have any shape that allows the slot 314 to function as a guide for the pin 296. The slot 314 can be integrally formed with the slide 302. The slot 314 can be formed by any machining, casting or forming processes.

[0105] The slot 314 can function to guide the pin 296. The pin 296, as discussed above, is coupled to the right tip 260. In the illustrated embodiment, the pin 296 extends from an external surface of the right extension 278. An edge of the slot 314 pushes the pin 296 as the slide 302 is moved. The shape of the slot 314 permits the pin to rotate about the right tip axis 258 as the slide 302 is moved. In some embodiments, the pin 296 can be adjusted to a number of discrete positions within the slot 314 (e.g., two, three, four, five, etc.). In some embodiments, the pin 296 can be adjusted to an infinite number of positions within the slot 314.

[0106] The slide 302 can be coupled to the hand tool 100 at two points of contact. The slide 302 can be coupled to the vertically extending portion 140 with the

retaining hole 298 and the guide 310. The slide 302 can be coupled to the tip 260 with the pin 296 and the slot 314. As the slide 302 translates, the screw (not shown) in the retaining hole 298 translates within the guide 310. As the slide 302 translates, the pin 296 translates within the slot 314.

[0107] The mechanism 300 can have a first position and a second position. The first position can correspond to forceps configuration. The second position can correspond to the scissor configuration. In the illustrated embodiments, the mechanism 300 can be in the first position when the slide 302 is lower on the vertically extending portion 240. There can be a larger separation between the top surface of the slide 302 and the top surface of the vertically extending portion 240. There can be a smaller separation between the bottom surface of the slide 302 and the bottom surface of the vertically extending portion 240. The bottom surface of the slide 302 and the bottom surface of the vertically extending portion 240 can be aligned. Figure 2A shows the mechanism 300 in the first position. When the mechanism 300 is in the first position, the left tip 160 and the right tip 260 can be used as forceps.

[0108] In the illustrated embodiments, the mechanism 300 can be in the second position when the slide 302 is higher on the vertically extending portion 240. There can be a smaller separation between the top surface of the slide 302 and the top surface of the vertically extending portion 240. The top surface of the slide 302 and the top surface of the vertically extending portion 240 can be aligned. There can be a larger separation between the bottom surface of the slide 302 and the bottom surface of the vertically extending portion 240. Figure 4 shows the mechanism 300 in the second position. When the mechanism 300 is in the second position, the left tip 160 and the right tip 260 can be used as scissors.

[0109] Figures 5A and 5B show the mechanism 300 in the first position. Figure 5A shows the front view of the hand tool 100 and Figure 5B shows a cross-section view along line B-B. In the first position, the pin 296 is near the lower end of the slot 314. The pin 296 is retained within the slot 314. In the illustrated embodiment, the pin 296 is not being acted on by any edge of the slot 314.

[0110] Figures 6A and 6B show the mechanism 300 in the second position. Figure 6A shows the front view of the hand tool 100 and Figure 6B shows a cross-section view along line M-M. In the second position, the pin 296 is near the upper end of the slot 314. As the slide 302 is moved upward along the vertically extending portion 240, an

edge of the slot 314 can come into contact with the pin 296. Further upward movement of the slide 302 can cause the edge of the slot 314 to exert a force on the pin 296. This force can cause the pin 296 to rotate about the right tip axis 258. Further upward movement of the slide 302 can cause the pin to rotate a quarter turn (e.g., 90°) or approximately a quarter turn (e.g., 80°, 85°, 90°, 95°, 100°, etc.). Rotation of the pin 296 can cause the right tip 260 to rotate within the recess 262 of the vertically extending portion 240. Rotation of the right tip 260 can exert a force on the left tip 160. The force exerted by the right tip 260 can be directly exerted on the left tip 160. As the right tip 260 is rotated within the recess 262, the left tip 160 can rotate within the recess 162.

[0111] Figures 7A-7C show the mechanism 300 in the first position. Figure 7A shows the side view of the hand tool 100. Figure 7B shows a cross-section view along line D-D. Figure 7C shows a cross-section view along line G-G. In the illustrated embodiment, the first position corresponds to the slide 302 being in a lower position as shown in Figure 7A.

[0112] The pin 296 can extend from the right extension 278 as shown in Figure 7B. The pin 296 can be retained within the slot 314. In the illustrated embodiment, the slot 314 is formed in a portion of the housing 308. The pin 296 can have a sufficient size to extend past the vertically extending portion 240 and into the housing 308. The pin 296 can have a greater dimension than the width of the vertically extending portion 240. The pin 296 can be positioned at an angle 202. The angle 202 can be approximately 45° from the vertical plane of the hand tool 100. Other angles are possible (e.g., 0°, 5°, 10°, 15°, 20°, 25°, 30°, 35°, 40°, 45°, 50°, 55°, 60°, 65°, 70°, 75°, 80°, 85°, 90°, etc.). The protrusion 294 can be received in the recess 194 as shown in Figure 7C.

[0113] Figures 8A-8C show the mechanism 300 in the second position. Figure 8A shows the side view of the hand tool 100. Figure 8B shows a cross-section view along line P-P. Figure 8C shows a cross-section view along line T-T. In the illustrated embodiment, the second position corresponds to the slide 302 being in a higher position as shown in Figure 8A.

[0114] The pin 296 can be rotated as shown in Figure 8B. The pin 296 can be positioned at an angle 204. The angle 204 can be approximately 45° from the vertical plane of the hand tool 100. Other angles are possible (e.g., 0°, 5°, 10°, 15°, 20°, 25°, 30°, 35°, 40°, 45°, 50°, 55°, 60°, 65°, 70°, 75°, 80°, 85°, 90°, etc.)The pin 296 can rotate approximately 90° as the mechanism 300 is moved from the first position to the second

position. The pin 296 can rotate approximately 90° as the hand tool 100 is transitioned between the forceps configuration and the scissors configuration. Other ranges of motion of the pin 296 are possible (e.g., 80°, 85°, 90°, 95°, 100°).

[0115] The protrusion 294 can be received in the recess 194 as shown in Figure 8C. The protrusion 294 can extend from the internal flat surface 284 of the right tip 260. The recess 194 can extend into the internal flat surface 184 of the left tip 160. The tips 160, 260 can rotate or pivot about the protrusion 294. The tips 160, 260 can rotate or pivot about the axis 198. The protrusion 294 can extend downward such that gravity aids in the retention of the protrusion 294 within the recess 194.

[0116] The functional configuration of the hand tool 100 is selected by the user by manipulating the mechanism 300. The user can slide a finger to move the slide 312. The user can manipulate the mechanism 300 while holding the hand tool 100. The slide 312 can change the position of the slot 314 relative to the pin 296. The mechanism 300 can exert a force on the pin 296 to rotate the pin 296. In the illustrated embodiment, an edge of the slot 314 of the mechanism 300 can act on the pin 296. The rotation of the pin 296 can rotate both tips 160, 260. The tips 160, 260 can rotate approximately 90° as the hand tool 100 is transitioned between the forceps configuration and the scissors configuration. Other ranges of motion of the tips 160, 260 are possible (e.g., 80°, 85°, 90°, 95°, 100°).

[0117] The mechanism 300 can convert translational motion of the slide 312 into rotational motion of pin 296. When the slide 312 is moved upward, the mechanism 300 can apply a rotational force to the pin 296. The pin 296 can be coupled to the right extension 278. The right extension 278 can have a cross-sectional shape of roughly a quarter-circle. The right extension 278 can rotate within the recess 262 of the vertically extending portion 240 as the pin 296 is rotated. The right extension 278 can rotate about the right hub 244 as the pin 296 is rotated. The right hub 244 can provide support to the right tip 260 as the pin 296 is rotated. The protrusion 272 and the hub recess 256 can maintain alignment of the right tip 260 as the right tip 260 is rotated. The right tip 260 can rotate about the right tip axis 258. The right tip 260 can rotate about the longitudinal axis 106.

[0118] The left extension 178 can have a cross-sectional shape of roughly a quarter-circle. The left extension 178 can rotate within the recess 162 of the vertically extending portion 140 as the pin 296 is rotated. The left extension 178 can rotate about

the left hub 144 as the pin 296 is rotated. The left hub 144 can provide support to the left tip 260 as the pin 296 is rotated. The protrusion 172 and the hub recess 156 can maintain alignment of the left tip 160 as the left tip 160 is rotated. The left tip 160 can rotate about the left tip axis 158. The left tip 160 can rotate about the longitudinal axis 106.

[0119] Both tips 160, 260 can rotate the same direction. In the illustrated embodiment, the right tip 260 rotates clockwise along the right hub 244 when the hand tool 100 transitions from the forceps configuration to the scissors configuration. The right tip 260 rotates counter-clockwise along the right hub 244 when the hand tool 100 transitions from the scissors configuration to the forceps configuration. In the illustrated embodiment, the left tip 160 rotates clockwise along the left hub 144 when the hand tool 100 transitions from the forceps configuration to the scissors configuration. The left tip 160 rotates counter-clockwise along the left hub 144 when the hand tool 100 transitions from the scissors configuration to the forceps configuration. The rotation in the clockwise direction is shown in Figures 7B and 8B. Other configurations are possible, where the mechanism rotates the tips clockwise to embody the transitions from the scissors configuration to the forceps configuration and counterclockwise to transitions from the forceps configuration to the scissors configuration.

[0120] In some embodiments, one mechanism 300 is provided. In the illustrated embodiment, the mechanism 300 is coupled to the right handle 232 and the pin 296 is provided on the right tip 260. The right tip 260 is the leader and the left tip 160 is the follower. The tips 160, 260 can be brought together and into contact in the intermediate configuration. In the intermediate configuration, movement of the right tip 260 can impart a force on the left tip 160 to cause rotation. In some embodiments, the mechanism 300 is coupled to the left handle 132 and the pin 296 is provided on the left tip 160. The left tip 160 can be the leader and the right tip 260 can be the follower. In some embodiments, more than one mechanism 300 is provided. One mechanism 300 is coupled to the right handle 232 and the pin 296 is provided on the right tip 260. Another mechanism is coupled to the left handle 132 and another pin is provided on the left tip 160. The user can move one or both mechanisms 300 to rotate the tips 160, 260.

[0121] The user selects the configuration of the hand tool 100 by movement of the mechanism 300. In some embodiments, the mechanism 300 is moved by a finger of the hand in which the hand tool 100 is held. In some embodiments, the mechanism 300 is moved by the thumb of the hand in which the hand tool 100 is held. In some

embodiments, the mechanism 300 is moved by a finger or thumb of the hand not holding the hand tool 100. The mechanism 300 allows the user to select between functional configurations with relative ease. The movement of the mechanism 300 can be intuitive to the user.

[0122] The hand tool 100 does not need to be removed from the surgical site to switch configurations. The mechanism 300 can be manipulated while the tips 160, 260 remain within the surgical site. The hand tool 100 requires the user to collapse the hand tool 100 in the intermediate configuration. This requires less space than either the forceps configuration or the scissors configuration. Once in the intermediate configuration, the user can transition between the forceps configuration and the scissors configuration. The hand tool 100 does not require any large movements to switch configurations.

[0123] Once the hand tool 100 is in the desired configuration, the scissors or forceps are operated conventionally. In the forceps configuration, movement of the handles 132, 232 causes the forceps to come together. The springs 124, 224 can return the handles 132, 232 to a neutral position. In the scissors configuration, movement of the handles 132, 232 causes the cutting edges of the tips 160, 260 to shear with respect to each other. The springs 124, 224 return the handles 132, 232 to a neutral position.

COMPONENT TO FACILITATE SCISSOR FUNCTION

[0124] The hand tool 100 can include a component to maintain alignment of the tips 160, 260 in the scissors configuration. This component can ensure engagement between the cutting edges 190, 290 to allow the tips 160, 260 to cut tissue. In the illustrated embodiment, the component is a sleeve 400. The sleeve 400 can extend along the length of one of the tips 160, 260 in the forceps configuration. The sleeve 400 can extend along the length of both tips 160, 260 in the scissors configuration. Other mechanisms are contemplated which function to hold the tips 160, 260 together in the scissors configuration.

[0125] Figures 9A-9D show an embodiment of the sleeve 400. Figure 9A shows the perspective view of the hand tool 100 with the sleeve 400. Figure 9B shows a top view and Figure 9C shows a side view. Figure 9D shows a cross-section view along line K-K. In Figure 9A, the right handle 232 is removed. The sleeve 400 is coupled to the left handle 132. The sleeve 400 can be coupled to the left handle 132 by welding, fasteners, glue, friction fit, pawl and ratchet, detent and protrusion, or other fixation

method. In the illustrated embodiment, the sleeve 400 is coupled to the vertically extending portion 140. The sleeve 400 extends from the vertically extending portion 140. The sleeve 400 extends along the left tip axis 158.

[0126] The sleeve 400 can include a proximal portion 402 near the vertically extending portion 140. The proximal portion 402 can be flat or substantially flat. The proximal portion 402 can be offset from the left tip 160. In some embodiments, the proximal portion 402 is not in contact with the left tip 160.

[0127] The sleeve 400 can include a distal portion 404. The distal portion 404 can have an internal surface 406 and an external surface 408. The internal surface 406 can be concave. The internal surface 406 can be sized to complement the external shape of the left tip 160. The diameter of the internal surface 406 can be equal or approximately equal to the diameter of the left tip 160. The diameter of the internal surface 406 can be slightly larger than the diameter of the external surface of the left tip 160 or a percentage thereof (e.g., 105%, 110%, 115%, 120%, 125%, 130%, 140%, 145%, 150%, etc.). The internal surface 406 can complement the external shape of the left tip 160 in the forceps configuration. The internal surface 406 can also complement the external shape of a portion of the left tip 160 and a portion of the right tip 260 in the scissors configuration. The external surface 408 of the distal portion 404 can be convex. The external surface 408 can have any shape (e.g., elliptical, oval, rectangular, square, etc.).

[0128] The sleeve 400 can include a middle portion 410 that transitions between the proximal portion 402 and the distal portion 404. The sleeve 400 can be tapered as shown in Figure 9B. The proximal portion 402 can surround a smaller portion of the left tip 160. The distal portion 404 can surround a larger portion of the left tip 160.

[0129] The sleeve 400 can extend along a portion of the tip 160. In the illustrated embodiment, the conical portion 186 extends distally from the sleeve 400 as shown in Figure 9C. The sleeve 400 is sized to permit movement of the tips 160, 260 in the forceps configuration and the scissors configuration.

[0130] In the forceps configuration (not shown), the distal portion 404 surrounds the left tip 160. The internal surface 406 can be adjacent to the left tip 106. The internal surface 406 can be in contact with or abut the left tip 106. The distal portion 404 can surround the entire left tip 160 or a portion thereof. The distal portion 404 can extend beyond the left tip 160. In the illustrated embodiment, the distal portion 404 can be semi-circular. The left tip 160 can be semi-circular.

[0131] In the scissors configuration shown in Figure 9D, the distal portion 404 surrounds a portion of the left tip 160 and a portion of the right tip 260. The internal surface 406 can be adjacent to a portion of the left tip 160 and a portion of the right tip 260. The internal surface 406 can be in contact with or abut a portion of the left tip 160 and a portion of the right tip 260. The distal portion 404 can surround a percentage of the left tip 160 (e.g., 30%, 40%, 50%, 60%, 70%, etc.). The distal portion 404 can surround a percentage of the right tip 260 (e.g., 30%, 40%, 50%, 60%, 70%, etc.). The distal portion 404 can surround half of the left tip 160 and half of the right tip 260. In the illustrated embodiment, the internal surface 406 can be semi-circular. The external surface of the left tip 160 and the right tip 260 can be semi-circular. The internal surface 406 allow the free rotation of the left tip 160 and the right tip 260 there within. The internal surface 406 can take other shapes or combination of shapes (e.g., semi-circular and flat, rectangular, circular, elliptical, square, rectangular, triangular, polygonal, sigmoid, etc.).

[0132] Figure 9D shows the sleeve 400 contacting both tips 160, 260 in the scissors configuration. The sleeve 400 can function to hold the tips 160, 260 together in the scissors configuration. The sleeve 400 can function to prevent separation of the tips 160, 260 in the scissors configuration. The sleeve 400 can function to prevent separation of the protrusion 294 and the recess 194 in the scissors configuration. The movement of the right tip 260 upward is reduced or prevented by the sleeve 400. The movement of the left tip 160 downward is reduced or prevented by the sleeve 400. Other mechanisms are contemplated which function to hold the tips 160, 260 together in the scissors configuration.

LOCKING COMPONENT TO MAINTAIN FUNCTIONAL CONFIGURATION

[0133] The hand tool 100 can include a locking mechanism 500. The locking mechanism 500 can function to reduce or prevent rotational movement of one or more of the extensions 178, 278. The locking mechanism 500 can function to reduce or prevent rotational movement of one or more of the tips 160, 260. The locking mechanism 500 can be locked when the hand tool 100 is in the forceps configuration, as shown in Figure 2A. The locking mechanism 500 can be locked when the hand tool 100 is in the scissors configuration, as shown in Figure 4. The locking mechanism 500 can be unlocked when the hand tool 100 is in the intermediate configuration, as shown in Figure 3.

[0134] Figures 10A-10C show an embodiment of the locking mechanism 500. The locking mechanism 500 can include a bar 502. The bar 502 can be any shape (e.g., straight, curved, bent, s-shape etc.). In the illustrated embodiment, the bar 502 has a bend. The bar 502 can be retained within a slot. The bar 502 can move within the slot in a direction perpendicular or substantially perpendicular to the right tip axis 258. The locking mechanism 500, including any components thereof, can move in any direction in order to prevent or allow rotation of the tips 160, 260 (e.g., rotating, parallel or substantially parallel to the longitudinal axis 106, parallel or substantially parallel to a tip axis 158, 258, perpendicular or substantially perpendicular to the longitudinal axis 106, perpendicular or substantially perpendicular to a tip axis 158, 258 etc.). In the illustrated embodiment, the slot can be located in the right hub 244. The slot can be located in the proximal portion 248 or the distal portion 252 of the right hub 244. In the illustrated embodiment, the slot can be located in the proximal portion 248. In some embodiments, the slot is within the right handle 232.

[0135] The bar 502 can be coupled to a pin 504. The pin 504 can be any shape (e.g., curved, straight, u-shaped, slanted, etc.). In the illustrated embodiment, the pin 504 is u-shaped. The pin 504 can include a proximal end which engages the bar 502. The pin 504 can include a distal end which engages the extension 278. In the illustrated embodiment, the pin 504 can engage a recess in the extension 278. In the illustrated embodiment, the pin 504 has two prongs. The upper prong of the pin 504 can engage the recess when the hand tool 100 is in the scissors configuration, as shown in Figures 10A-10C. The lower prong of the pin 504 can engage the recess when the hand tool 100 is in the forceps configuration. The pin 504 can prevent rotation of the extension 278 when a prong of the pin 504 engages the recess of the extension 278.

[0136] The bar 502 can extend from an internal surface of the handle 232 or hub with the hub installed in the handle. The action of abutting the handles 132, 232 can cause the bar 502 to move within the slot. This action can unlock the locking mechanism 500. The locking mechanism 500 can be unlocked when the handles 132, 232 are brought toward each other. In some embodiments, the left handle 132 will exert a force on the bar 502. In some embodiments, the hub 144 will exert a force on the bar 502. In some embodiments, the bar from the contralateral locking mechanism will exert force. The bar 502 can move outward from the longitudinal axis 106. The bar 502 can move toward the handle 232. The shape of the bar 502 can cause the pin 504 to be moved along the right

tip axis 258. The pin 504 can translate toward the proximal end 116 as the bar 502 is moved toward the handle 232. The pin 504 can disengage the recess of the extension 278 when the pin 504 translates proximally. The upper prong of the pin 504 can disengage the recess when the pin 504 translates proximally. The lower prong of the pin 504 can disengage the recess when the pin 504 translates proximally. The tips 160, 260 can be rotated when the pin 504 disengages the recess in the right extension 278.

[0137] The locking mechanism 500 can have a neutral position. The neutral position can be the locked position. In the neutral position, a prong of the pin 504 can engage the recess in the extension 278. The locking mechanism 500 can return to the neutral position via a spring. In other embodiments, the locking mechanism 500 can be returned to the neutral position by other means (e.g., magnets, gravity, manually force, etc.). The locking mechanism 500 can be manually moved by the user. The locking mechanism 500 can be returned to the neutral position by the action of separating the handles 132, 232.

[0138] In some embodiments, the locking mechanism 500 is placed within the recess 262 in the vertically extending portion 240. The locking mechanism 500 would block the rotational movement of the right extension 278 in the recess 262. In some embodiments, the locking mechanism 500 is placed within the recess 162 in the vertically extending portion 140. The locking mechanism 500 would block the rotational movement of the left extension 178 in the recess 162. In some embodiments, the locking mechanism 500 can remain in one recess 162, 262. In some embodiments, a locking mechanism 500 can be provided for each recess 162, 262. In some embodiments, the locking mechanism 500 can move between the recesses 162, 262. For instance, the locking mechanism 500 can be located in the recess 262 when the hand tool 100 is in the forceps configuration. The locking mechanism 500 can rotate into the recess 162 when the hand tool 100 is in the scissors configuration.

[0139] In the illustrated embodiment, the locking mechanism 500 can be included in the right section 202. In some embodiments, the locking mechanism 500 can be included in the left section 102. In some embodiments, the locking mechanism 500 can be included in both the left section 102 and the right section 202. Other embodiments are contemplated to prevent the extensions 178, 278 from rotating (e.g., spring, detent, magnet, etc.).

[0140] In other embodiments, the user can manipulate an interface (not shown) to unlock the locking mechanism 500. The neutral position can be that the locking mechanism 500 is locked. For instance, the interface (not shown) can be a button that when depressed would unlock the locking mechanism 500. The interface (not shown) can be a slide that can have a position when the locking mechanism 500 is locked and a position when the locking mechanism 500 is unlocked. Other configurations of interfaces (not shown) are contemplated.

[0141] The hand tool 100 can be generally composed of metal alloys, plastic, or other suitable biocompatible material. The hand tool 100 can be made by conventional machining and metal fabrication techniques, plastic fabrication techniques, and finishing processes including but not limited to milling, lathing, electrodischarge and welding, injection molding, powder coating and painting. The hand tool 100 can be optionally coated with one or more coatings, including but not limited to plastic, rubber, powder coat and paint or any combination thereof. The hand tool 100 can comprise multiple parts assembled and delivered to its intended user. The hand tool 100 can be sterilized before it is provided to the intended user.

[0142] Different methods of switching configurations, different mechanism for rotating the tips, different configurations of the pin are contemplated. Further, the hand tool 100 may be configured to provide different tool functions than forceps and scissors described herein. Further, the hand tool 100 may have additional functional configurations corresponding to different tools. The hand tool 100 may be used in conjunction with other tools, for instance an operating microscope.

[0143] Other embodiments of the hand tool are shown in U.S. Provisional Patent Application No. 61/906337 filed November 19, 2013, the disclosures of which is incorporated by reference herein in its entirety. The hand tool 100 described herein can have any of the features, components, or subcomponents described in the provisional application. In the illustrated embodiment of Figures 1-9 in the provisional application, the handle 132 can include an additional longitudinally extending portion located distal of the vertically extending portions 140, 240. This additional longitudinally extending portion is shown in Figures 1-3 of U.S. Provisional Patent Application No. 61/906337. The additional longitudinally extending portion of the left handle 132 can include the recess 162. The recess 162 can be enclosed or partially enclosed by the additional

longitudinally extending portion. The recess 162 can be semi-circular as described herein. The recess 162 can be sized to receive the left extension 178.

[0144] In some embodiments, the right handle 232 can be a mirror image of the left handle 132. The right handle 232 can include an additional longitudinally extending portion. The additional longitudinally extending portion can include the recess 262. The recess 262 can be enclosed or partially enclosed by the additional longitudinally extending portion. The recess 262 can be semi-circular as describe herein. The recess 262 can be sized to receive the right extension 278.

[0145] The tips 160, 260 can include a respective longitudinally extending portion 182, 282, as shown in Figure 5 of U.S. Provisional Patent Application No. 61/906337. The longitudinally extending portion 182, 282 can be semi-circular. The tips 160, 260 can include a respective conical portion 186, 286. The tips 160, 260 can include a respective extension 178, 278. The extensions 178, 278 can be quarter-circular. At least one of the extensions 178, 278 can include an engaging surface. The engaging surface can be a pin. The pin can extend parallel or substantially parallel to the tip axis 158, 258. The engaging surface can be rotated to the extensions 178, 278 within the recesses 162, 262. The engaging surface can be rotated to transition the hand tool between a forceps configuration and a scissors configuration.

[0146] The mechanism 300 can include a slide 302 as shown in Figure 6 of U.S. Provisional Patent Application No. 61/906337. The slide 312 can include a slot 314 configured to interact with the pin. The slide is configured to move upward and downward. The movement of the slide can rotate the engaging surface. The engaging surface can rotate the extension 178, 278 to which the engaging surface is attached. The extension can rotate one of the tips 160, 260 which can impart a force of the other of the tips 160, 260.

[0147] Although this disclosure has been described in the context of certain embodiments and examples, it will be understood by those skilled in the art that the disclosure extends beyond the specifically disclosed embodiments to other alternative embodiments and/or uses and obvious modifications and equivalents thereof. In addition, while several variations of the embodiments of the disclosure have been shown and described in detail, other modifications, which are within the scope of this disclosure, will be readily apparent to those of skill in the art. It is also contemplated that various combinations or sub-combinations of the specific features and aspects of the

embodiments may be made and still fall within the scope of the disclosure. For example, features described above in connection with one embodiment can be used with a different embodiment described herein and the combination still fall within the scope of the disclosure. It should be understood that various features and aspects of the disclosed embodiments can be combined with, or substituted for, one another in order to form varying modes of the embodiments of the disclosure. Thus, it is intended that the scope of the disclosure herein should not be limited by the particular embodiments described above.

WHAT IS CLAIMED IS:

1. A surgical tool comprising:
 - a first handle comprising a proximal portion and a distal portion and a first recess in the distal portion;
 - a second handle comprising a proximal portion and a distal portion and a second recess in the distal portion;
 - a first tip disposed in the first recess and extending distally therefrom, the first tip having a first external surface and a first internal surface; and
 - a second tip disposed in the second recess and extending distally therefrom, the second tip having a second external surface and a second internal surface;wherein the surgical tool has a first configuration wherein the first and second tips operate as forceps;
 - wherein the surgical tool has a second configuration wherein the first and second tips operate as scissors;
 - wherein rotation of the first tip and the second tip within their respective recesses transitions the surgical tool between the first configuration and the second configuration.
2. The surgical tool of Claim 1, wherein the first inner surface and the second inner surface are configured to abut each other during rotation of the first tip and the second tip within their respective recesses to transition the surgical tool between the first configuration and the second configuration.
3. The surgical tool of Claim 1, wherein the second tip comprises a pin extending from the second external surface, and rotation of the pin relative to the second handle causes rotation of the second tip relative to the second recess and transitions the surgical tool between the first configuration and the second configuration.
4. The surgical tool of Claim 3, wherein rotation of the pin relative to the second handle rotates the first tip relative to the first recess.
5. The surgical tool of Claim 3, wherein the pin is substantially perpendicular to a longitudinal axis of the second tip.
6. The surgical tool of Claim 1, wherein the first tip comprises a first electrode and the second tip comprises a second electrode.

7. The surgical tool of Claim 6, wherein the first tip and the second tip are configured to interact as electrocautery bipolar forceps in the first configuration.

8. The surgical tool of Claim 1, wherein in the second configuration, the first and second inner surfaces are configured to shear past each other.

9. The surgical tool of Claim 1, wherein one of the first tip and the second tip comprises a recess and the other of the first tip and the second tip comprises a protrusion, wherein the protrusion is configured to be received relative to the recess in the second configuration to provide an axis about which the tips can rotate.

10. The surgical tool of Claim 1, further comprising a sleeve surrounding at least a portion of the first tip.

11. The surgical tool of Claim 1, further comprising a locking mechanism configured to prevent rotation of the second tip.

12. The surgical tool of Claim 1, wherein the first handle is coupled to the second handle near a proximal end of the surgical tool.

13. The surgical tool of Claim 1, further comprising one or more springs attached to the handles to bias the first and second tips to a neutral position.

14. A method of using a surgical tool comprising:

providing a first handle and a second handle coupled to each other, the first handle having a first tip extending distally therefrom and the second handle having a second tip extending distally therefrom, wherein the first and second tips are configured for use as forceps; and

rotating the first tip relative to the first handle and rotating the second tip relative to the second handle, wherein the rotation reconfigures the first and second tips for use as scissors.

15. The method of Claim 14, further comprising bringing inner surfaces of the first and second tips into contact with each other so that longitudinal axes of the first and second tips are aligned, and then rotating the first tip relative to the first handle and rotating the second tip relative to the second handle.

16. The method of Claim 15, wherein after rotating the first tip relative to the first handle and rotating the second tip relative to the second handle, the inner surfaces of the first and second tips are configured to shear past each other.

17. The method of Claim 14, further comprising rotating a pin extending from one of the first tip and the second tip to rotate the first tip relative to the first handle and rotate the second tip relative to the second handle.

18. The method of Claim 14, further comprising applying electrical energy to tissue with the first tip and the second tip.

19. The method of Claim 14, wherein rotating the first tip relative to the first handle and the second tip relative to the second handle further comprises rotating the first tip ninety degrees and rotating the second tip ninety degrees.

20. A surgical tool comprising:

a first handle;

a first tip coupled to the first handle and configured to rotate relative to the first handle, the first tip having a first internal surface;

a second handle; and

a second tip coupled to the second handle and configured to rotate relative to the second handle, the second tip having a second internal surface,

wherein the surgical tool has a first configuration wherein the first internal surface and the second internal surface are generally vertical,

wherein movement of the first handle or the second handle changes the distance between the first tip and the second tip in the first configuration,

wherein the surgical tool has a second configuration wherein the first internal surface and the second internal surface are generally horizontal,

wherein movement of the first handle or the second handle shears an edge of the first tip past an edge of the second tip in the second configuration,

wherein the tips are configured to rotate to transition between the first configuration and the second configuration.

21. A surgical tool comprising:

a first handle and a second handle, wherein the first handle and the second handle are configured to have a first configuration and a second configuration;

wherein in the first configuration the tool operates as forceps and in the second configuration the tool operates as scissors.

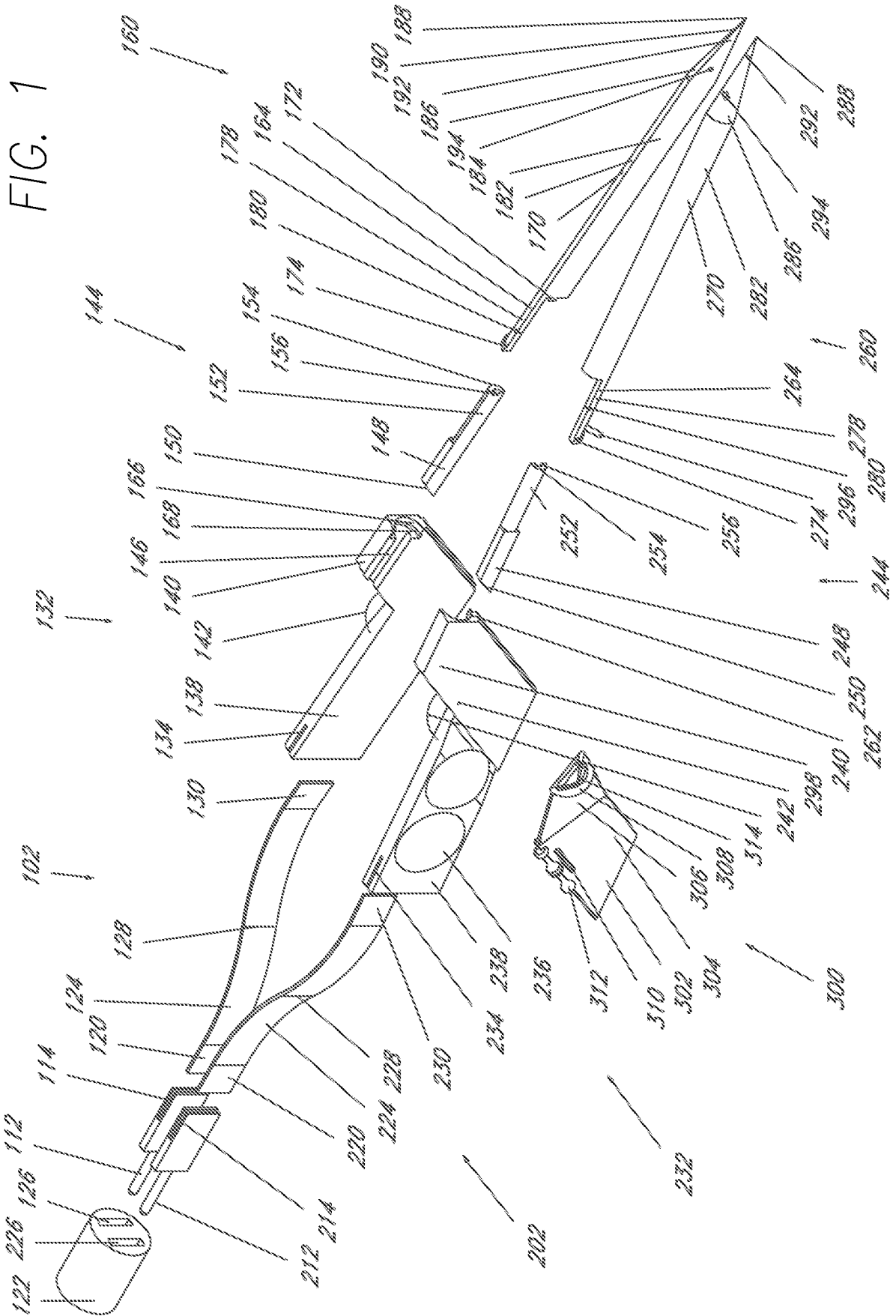

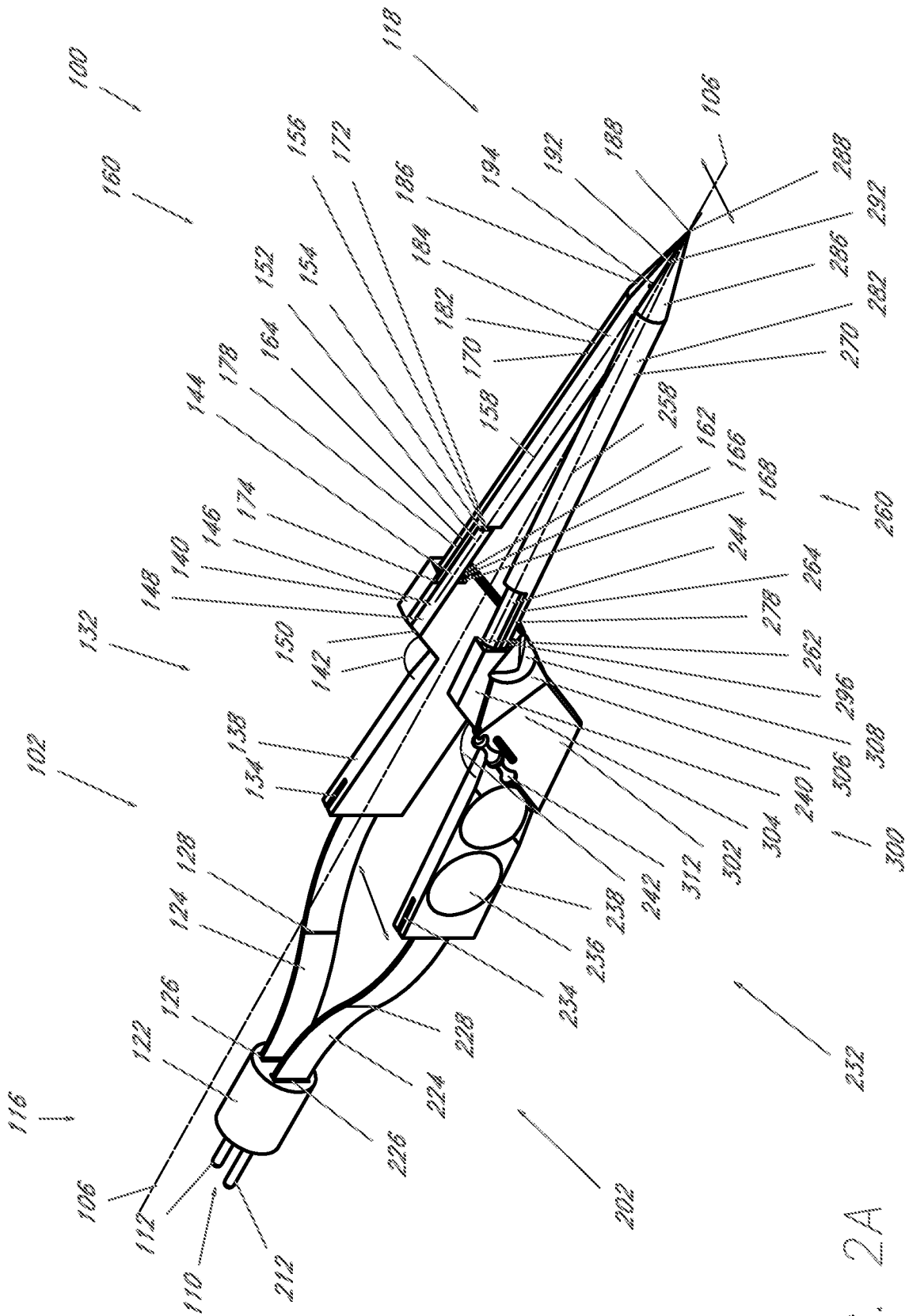

FIG. 2A

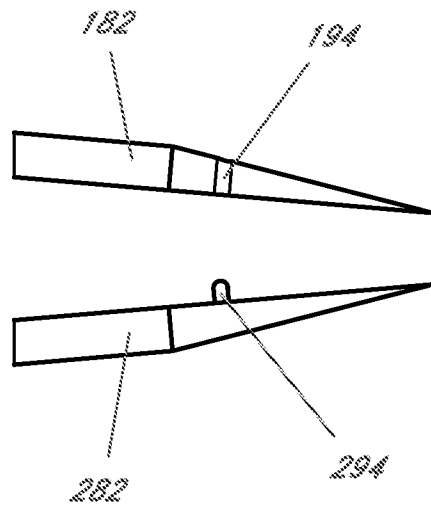
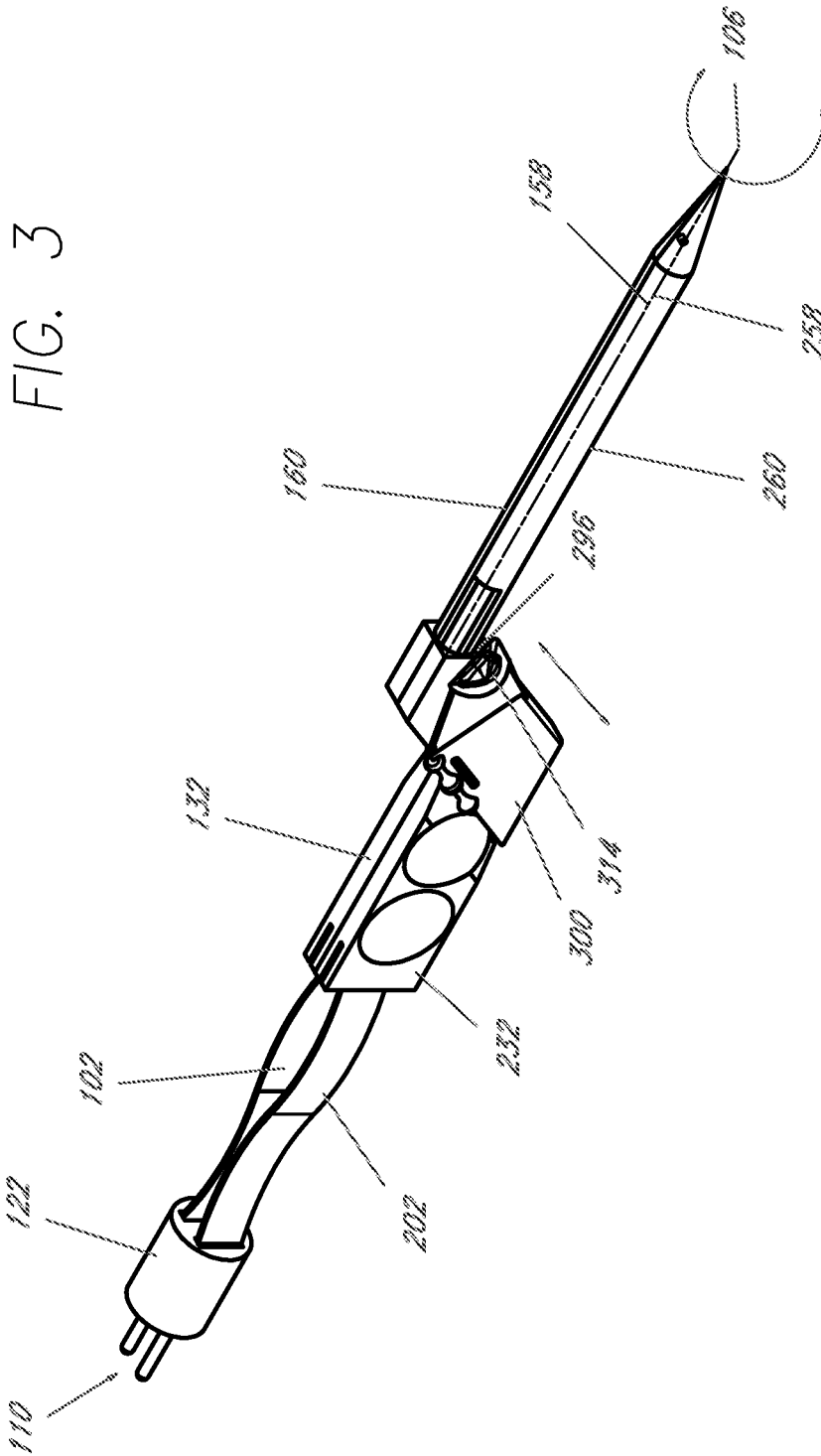

FIG. 2B



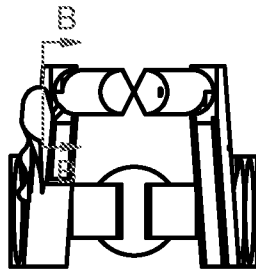
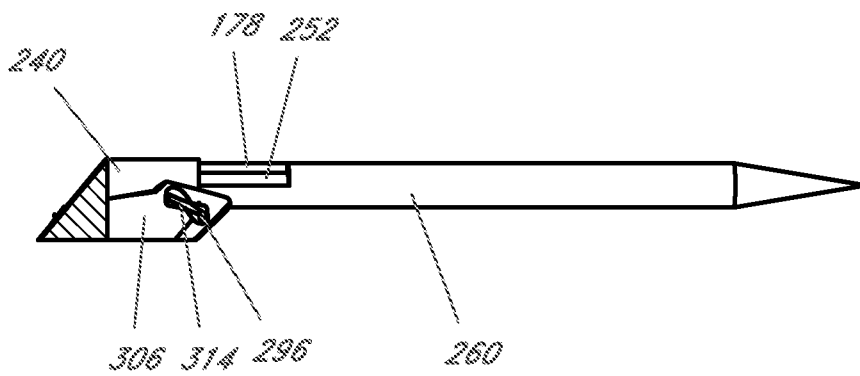

FIG. 5A



SECTION B-B
Scale 2:1

FIG. 5B

7/14

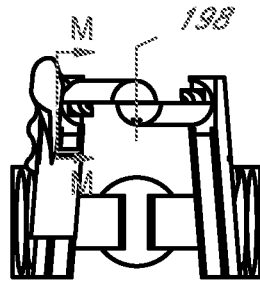

FIG. 6A

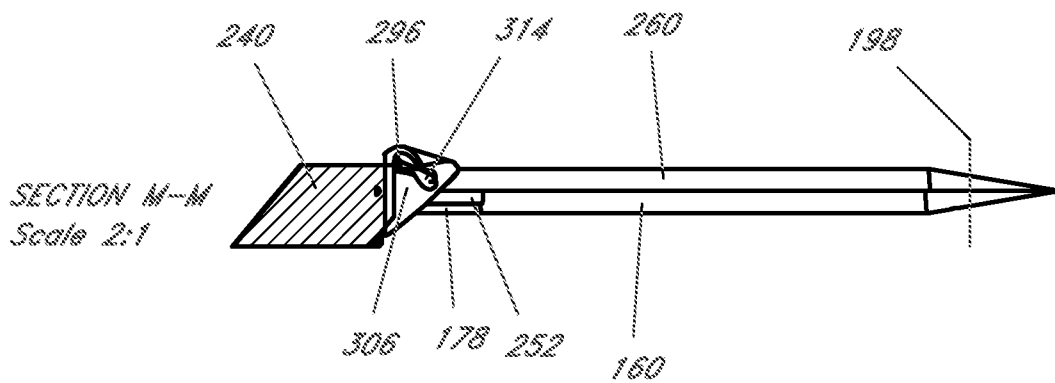

FIG. 6B

8/14

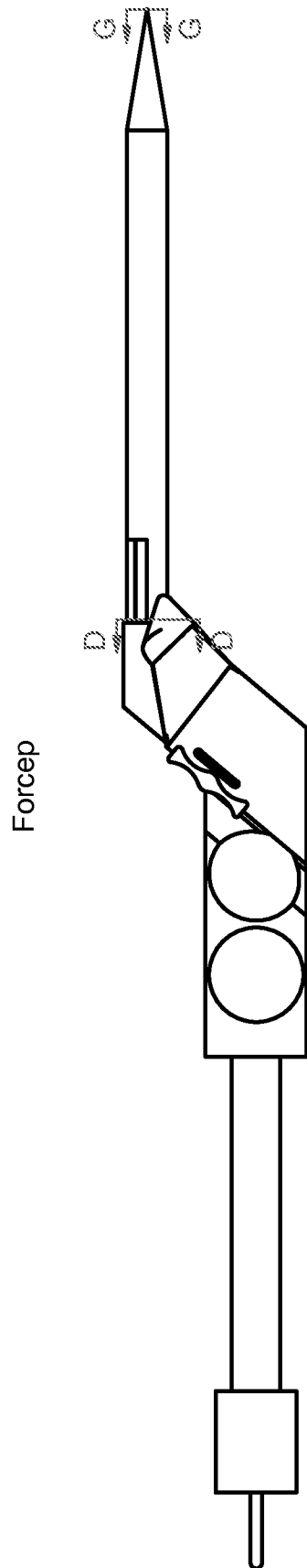
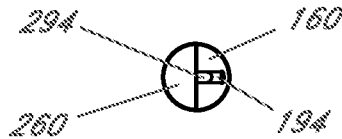

FIG. 7A

9/14

Forcep



VIEW G-G
Scale 2:1

FIG. 7C

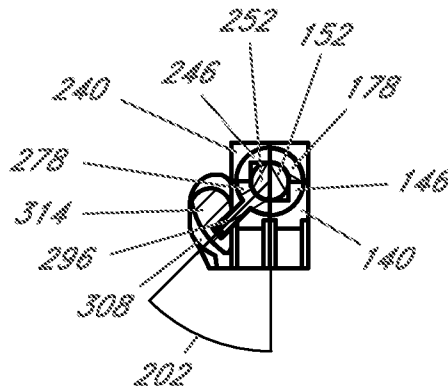

SECTION D-D
Scale 2:1

FIG. 7B

10/14

Scissor

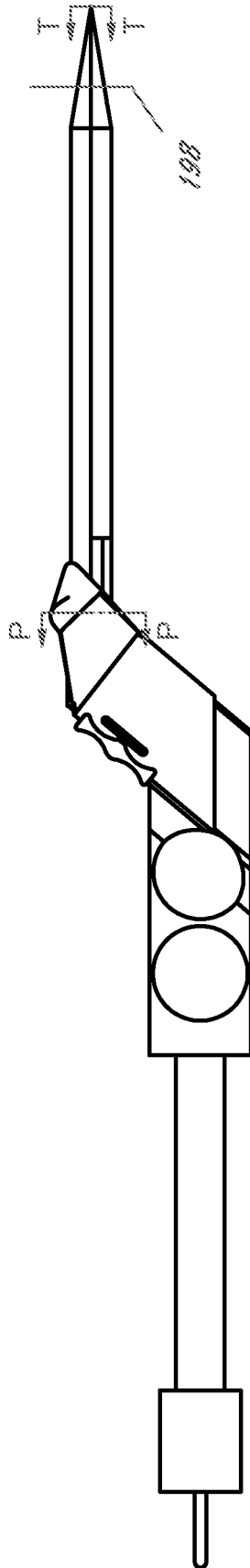
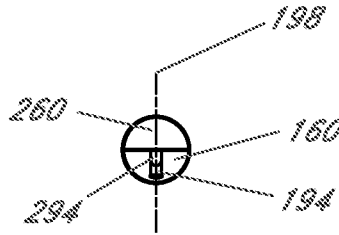

FIG. 8A

11/14

Scissor



VIEW T-T
Scale 2:1

FIG. 8C

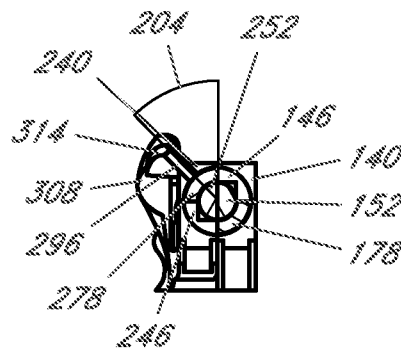

SECTION P-P
Scale 2:1

FIG. 8B

12/14

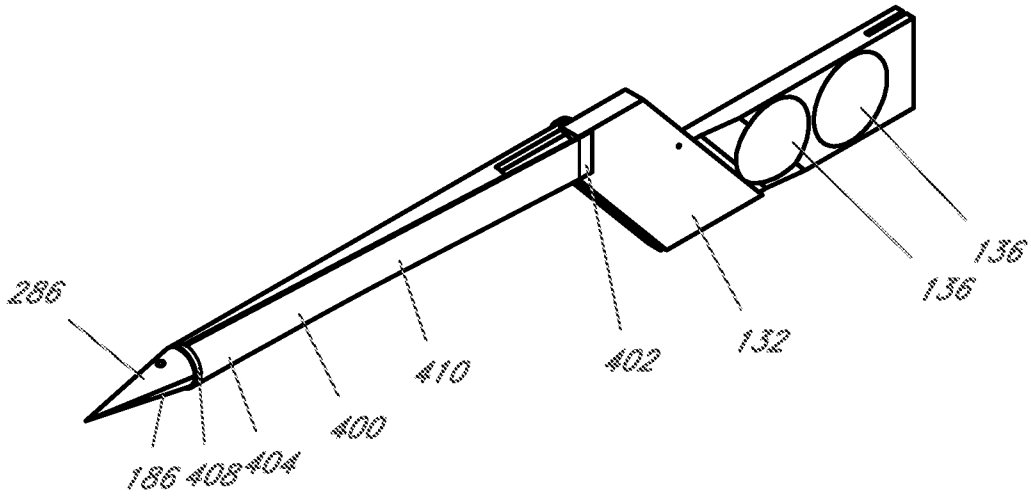

FIG. 9A

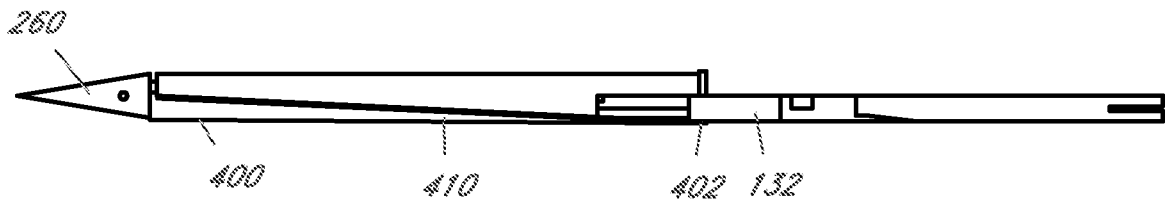

FIG. 9B

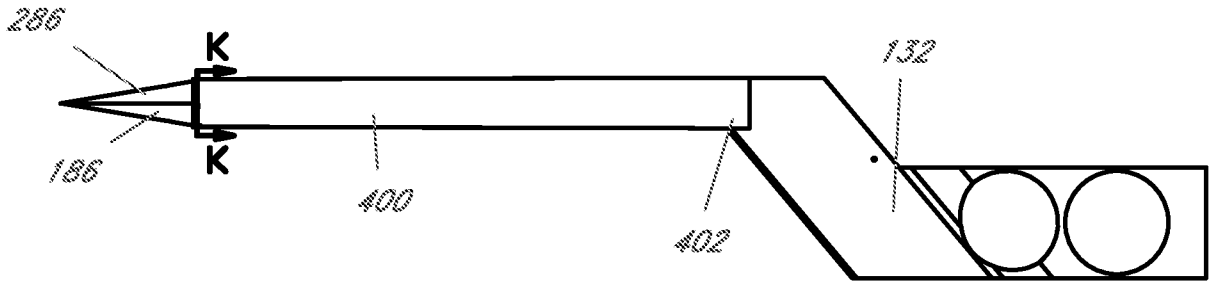
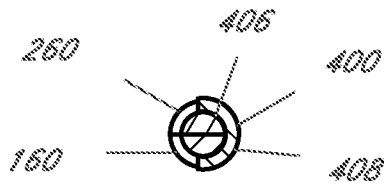

FIG. 9C



SECTION K-K
Scale 2:1

FIG. 9D

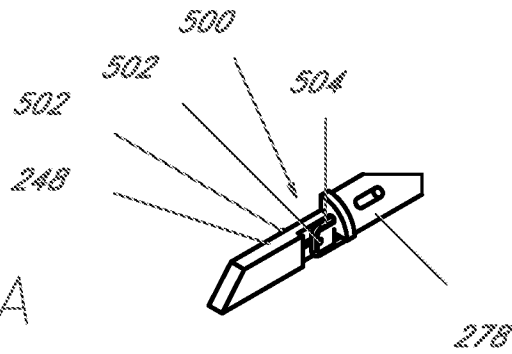

FIG. 10A

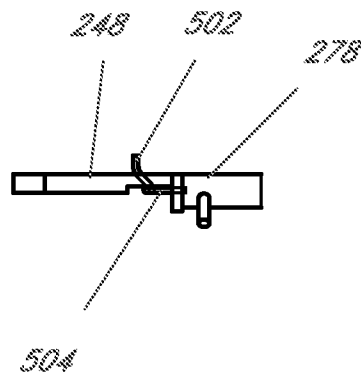

FIG. 10B

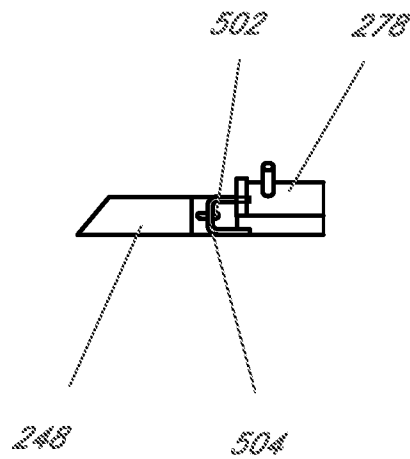

FIG. 10C

A. CLASSIFICATION OF SUBJECT MATTER**A61B 18/12(2006.01)i, A61B 18/14(2006.01)i, A61B 17/285(2006.01)i, A61B 17/3201(2006.01)i**

According to International Patent Classification (IPC) or to both national classification and IPC

B. FIELDS SEARCHED

Minimum documentation searched (classification system followed by classification symbols)

A61B 18/12; A61B 17/3201; A61B 18/14; A61B 18/04; A61B 17/295; A61B 18/18; A61B 17/285

Documentation searched other than minimum documentation to the extent that such documents are included in the fields searched

Korean utility models and applications for utility models

Japanese utility models and applications for utility models

Electronic data base consulted during the international search (name of data base and, where practicable, search terms used)

eKOMPASS(KIPO internal) & Keywords: surgical multi-tool, scissors, forceps

C. DOCUMENTS CONSIDERED TO BE RELEVANT

Category*	Citation of document, with indication, where appropriate, of the relevant passages	Relevant to claim No.
X	US 2012-0209305 A1 (DEODHAR, CHIMAY et al.) 16 August 2012 See abstract; claims 1-6; paragraphs [0006]-[0053]; and figures 4a-5c.	21
A		1-20
A	US 2010-0023001 A1 (HOSAKA, MAKOTO et al.) 28 January 2010 See abstract; claims 1-10; and figures 3-6.	1-21
A	US 2003-0073987 A1 (SAKURAI, TOMOHISA et al.) 17 April 2003 See abstract; claims 1-20; and figures 1 and 14-15.	1-21
A	US 6773434 B2 (CIARROCCA, SCOTT) 10 August 2004 See the whole document.	1-21
A	MATSUMURA, NOBUHISA, A new bayonet spring microsurgical instrument handle with a bar for microneurosurgery, Surgical Neurology International, 2012, Vol. 3, No. 152, pages 1-3(internal) See the whole document.	1-21

 Further documents are listed in the continuation of Box C. See patent family annex.

* Special categories of cited documents:

"A" document defining the general state of the art which is not considered to be of particular relevance

"E" earlier application or patent but published on or after the international filing date

"L" document which may throw doubts on priority claim(s) or which is cited to establish the publication date of another citation or other special reason (as specified)

"O" document referring to an oral disclosure, use, exhibition or other means

"P" document published prior to the international filing date but later than the priority date claimed

"T" later document published after the international filing date or priority date and not in conflict with the application but cited to understand the principle or theory underlying the invention

"X" document of particular relevance; the claimed invention cannot be considered novel or cannot be considered to involve an inventive step when the document is taken alone

"Y" document of particular relevance; the claimed invention cannot be considered to involve an inventive step when the document is combined with one or more other such documents, such combination being obvious to a person skilled in the art

"&" document member of the same patent family

Date of the actual completion of the international search

12 March 2015 (12.03.2015)

Date of mailing of the international search report

13 March 2015 (13.03.2015)

Name and mailing address of the ISA/KR

International Application Division
Korean Intellectual Property Office
189 Cheongsu-ro, Seo-gu, Daejeon Metropolitan City, 302-701,
Republic of Korea

Facsimile No. ++82 42 472 7140

Authorized officer

CHANG, Bong Ho

Telephone No. +82-42-481-3353



INTERNATIONAL SEARCH REPORT

Information on patent family members

International application No.

PCT/US2014/066432

Patent document cited in search report	Publication date	Patent family member(s)	Publication date
US 2012-0209305 A1	16/08/2012	CN 103547225 A	29/01/2014
		EP 2584980 A2	01/05/2013
		KR 10-2013-0109024 A	07/10/2013
		US 8870902 B2	28/10/2014
		WO 2011-161626 A2	29/12/2011
US 2010-0023001 A1	28/01/2010	AT 506905 T	15/05/2011
		CN 101553177 A	07/10/2009
		CN 101553177 B	07/03/2012
		DE 602007014245 D1	09/06/2011
		EP 2082694 A1	29/07/2009
		EP 2082694 A4	03/03/2010
		EP 2082694 B1	27/04/2011
		JP 5100661 B2	19/12/2012
		KR 10-1156817 B1	18/06/2012
		KR 10-2009-0077798 A	15/07/2009
		US 8313483 B2	20/11/2012
		WO 2008-056732 A1	15/05/2008
WO 2008-056732 A1	15/05/2008		
US 2003-0073987 A1	17/04/2003	JP 2003-116871 A	22/04/2003
		JP 2003-126110 A	07/05/2003
		US 2005-0101945 A1	12/05/2005
		US 7938779 B2	10/05/2011
US 6773434 B2	10/08/2004	DE 60210880 D1	01/06/2006
		DE 60210880 T2	10/05/2007
		EP 1293172 A1	19/03/2003
		EP 1293172 B1	26/04/2006
		ES 2262760 T3	01/12/2006
		US 2003-0055424 A1	20/03/2003