

S. SZUBERT.  
ELECTRIC ARC LAMP.  
APPLICATION FILED OCT. 18, 1899.

998,212.

Patented July 18, 1911.

Fig.1

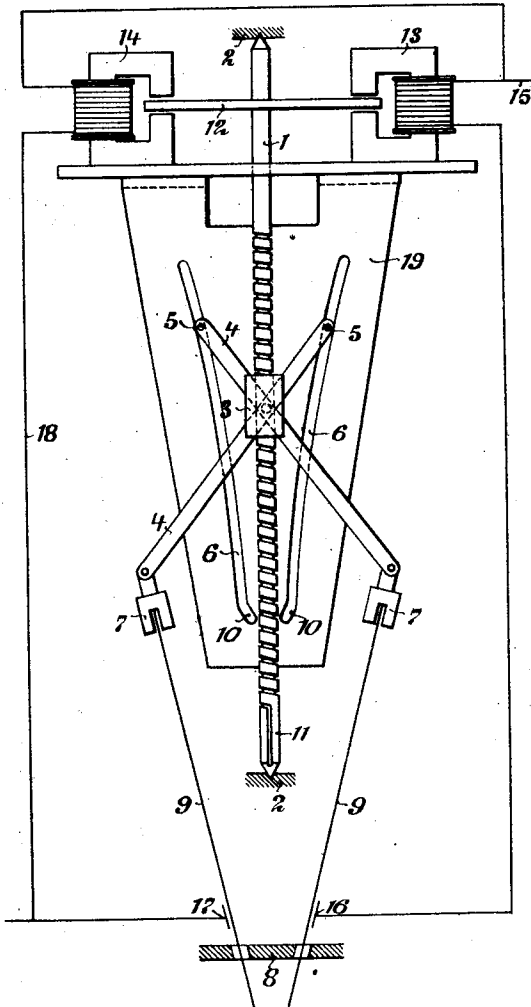

Fig.2

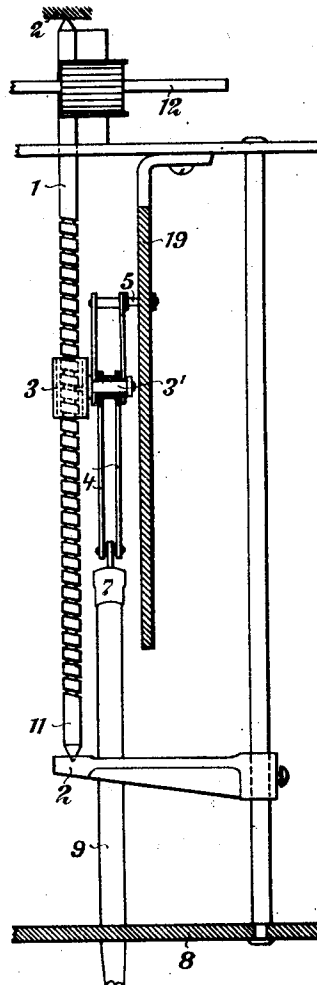

Fig.3



Witnesses:  
L. C. Barkley.  
E. M. Moore.

Inventor:  
Stanislaw Szubert,  
by Frank S. Hallman,  
attor.

# UNITED STATES PATENT OFFICE.

STANISLAW SZUBERT, OF PANKOW, NEAR BERLIN, GERMANY.

ELECTRIC-ARC LAMP.

998,212.

Specification of Letters Patent. Patented July 18, 1911.

Application filed October 18, 1909. Serial No. 523,227.

To all whom it may concern:

Be it known that I, STANISLAW SZUBERT, a subject of the Czar of Russia, and residing at Pankow, near Berlin, Germany, have invented certain new and useful Improvements in Electric-Arc Lamps, of which the following is a specification.

My invention relates to arc-lamps and a primary object is to provide an improved electric arc-lamp in which lazy-tongs or a scissor-like system of levers is employed carrying at one end the electrode-holders and at the other end members sliding in guides, whereas the member regulating the feed, *e. g.* a nut on a screw, engages at the point of intersection of the levers. Said members on the top ends of the levers are either guided rectilinearly or in such curves that the electrode-holders move exactly in the longitudinal direction of the electrodes. The guides are inwardly curved at their lower ends, and consequently when the guided ends of the levers are guided by these parts the lower ends of the electrodes are drawn apart and the arc ruptured.

One constructional form of my improved arc-lamp is represented diagrammatically by way of example in the accompanying drawing, wherein:—

Figure 1 is a diagrammatic front elevation, Fig. 2 a side elevation, partly in section, and Fig. 3 shows a modified detail.

Referring to the drawing, a spindle 1 having a helical groove or screw is journaled revolvably in bearings 2. On said spindle slides the sleeve 3 carrying a pin 3' driven by the screw and forming the fulcrum of the levers 4. The upper pair of ends of levers 4 has pins 5 sliding in the curved guides 6, whereas the lower pair of ends carries the holders 7 carrying the electrodes 9 guided in holes in the plate 8 above the arc. The guides 6 are provided in the plate 19 attached to the base-plate 20 of the lamp.

When the screw is rotated in the one sense, its sleeve and the levers 4 connected with it descend, and the electrode-holders move exactly in the longitudinal direction of the electrodes 9 in consequence of the curved guides 6. These guides, for the upper ends of the levers 4 suddenly change in direction and turn inward at their lower ends 10, and the corresponding end 11 of the spindle is without thread or the thread runs parallel to the longitudinal axis of the spindle. Now as soon as the pins 5 arrive at the inwardly-

directed portion of the guides, the sleeve 3 will fall down the portion of the spindle without thread, while the two pairs of ends of levers 4 come together so that the ends of the electrodes guided in the holes of plate 8 suddenly move apart and rupture the arc.

Current may be supplied by conductor 15 to the series electromagnet 13 and thence through contact 16 to the one carbon 9, and from the other carbon through contact 17 to the source of current. Electromagnet 14 is connected in shunt across the arc by conductor 16.

In an alternating current lamp, as shown in the drawing, spindle 1 is rotated by the disk 12 fixed on it and composed of a suitable metal, *as. e. g.* aluminum, moving to and fro between the poles of a series electromagnet 13 and a shunt electromagnet 14. When the lamp is started the disk rotates under the influence of the shunt electromagnet until the carbon tips contact one another. Then the series electromagnet rotates the disk so that the carbon tips go apart until the normal strength of current is obtained, whereas the shunt electromagnet moves the carbon tips together, in the case of too great tension, until the normal tension is brought about.

I claim:—

1. In an electric arc-lamp, the combination, with a system of levers pivotally connected together, holders attached to one end of the same, and electrodes sloping toward one another in said holders, of a fixed member having two guides, electromagnetically-operated means for moving the pivot of said system of levers rectilinearly, the other end of the system of levers being guided in said guides and causing said electrode-holders to move in the longitudinal direction of said electrodes.

2. In an electric arc-lamp, the combination, with a system of levers pivotally connected together, holders attached to one end of the same and electrodes sloping toward one another in said holders, of electromagnetically-operated means for moving the pivot of said system of levers rectilinearly, and curved guides guiding the other end of the system of levers and causing said electrode-holders to move in the longitudinal direction of said electrodes, the curves of said guides running in a direction opposite to the curves described by the ends of said system of levers carrying said holders.

3. In an electric arc-lamp, the combination, with a system of levers pivotally connected together, holders pivotally attached to one end of the same, a plate having holes, and electrodes sloping toward one another, guided in said holes and held in said holders, of a spindle provided with a helical groove, a sleeve slidable on said spindle, a pivot of said system of levers passing through said sleeve into said groove, and outwardly-curved guides bent suddenly inward at their lower ends guiding the other end of the system of levers.

4. In an electric arc-lamp, the combination, with a system of levers pivotally connected together, holders pivotally attached to one end of the same, a plate having holes, and electrodes sloping toward one another, guided in said holes and held in said holders, of an electromagnetically-operated spindle provided with an endless screw thread, a sleeve slidable on said spindle, a pivot of said system of levers passing through said sleeve into said screw thread, and outwardly-curved guides guiding the other end of the system of levers, said screw thread

running parallel with the axis of the spindle at the lower end of the same.

5. In an alternating current arc-lamp, the combination, with a system of levers pivotally connected together, holders pivotally attached to one end of the same, a plate having holes, and electrodes sloping toward one another, guided in said holes and held in said holders, of a spindle provided with a helical groove, electromagnetic means comprising a series electromagnet and a shunt electromagnet, a metal disk fixed on said spindle and revoluble between the poles of said electromagnets, a sleeve slidable on said spindle, a pivot of said system of levers passing through said sleeve into said groove, and outwardly-curved guides bent suddenly inward at their lower ends guiding the other end of the system of levers.

In testimony whereof, I affix my signature in the presence of two witnesses.

STANISLAW SZUBERT.

Witnesses:

WOLDEMAR HAUPT,  
HENRY HASPER.