

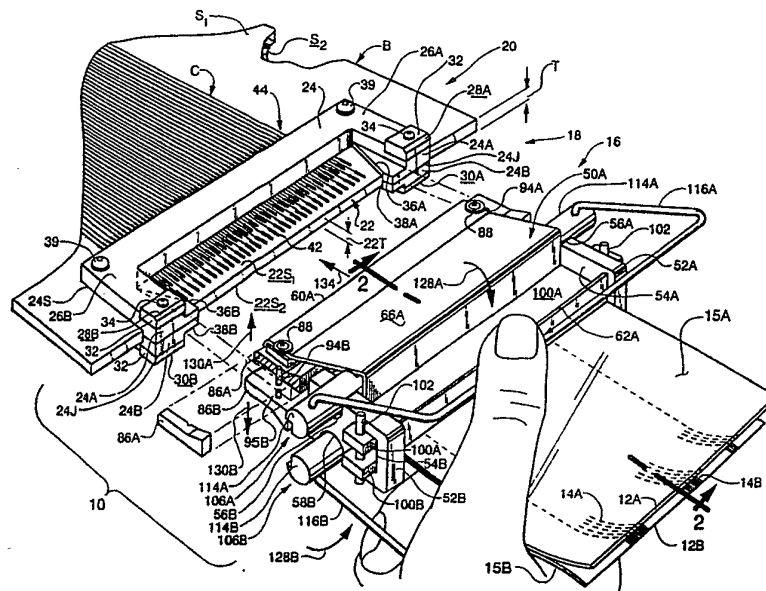

## INTERNATIONAL APPLICATION PUBLISHED UNDER THE PATENT COOPERATION TREATY (PCT)

<p>(51) International Patent Classification <sup>5</sup> : H01R 9/09, 9/07, 13/15 H01R 13/62, 23/66, 23/70</p>	A1	<p>(11) International Publication Number: <b>WO 93/10577</b></p> <p>(43) International Publication Date: 27 May 1993 (27.05.93)</p>
<p>(21) International Application Number: PCT/US92/09987</p> <p>(22) International Filing Date: 18 November 1992 (18.11.92)</p> <p>(30) Priority data: 07/793,513 18 November 1991 (18.11.91) US 07/946,003 15 September 1992 (15.09.92) US</p> <p>(60) Parent Application or Grant (63) Related by Continuation US 07/946,003 (CIP) Filed on 15 September 1992 (15.09.92)</p> <p>(71) Applicant (for all designated States except US): E.I. DU PONT DE NEMOURS AND COMPANY [US/US]; 1007 Market Street, Wilmington, DE 19898 (US).</p>	<p>(72) Inventors; and (75) Inventors/Applicants (for US only) : ELCO, Richard, Alva [US/US]; 26 Oakwood, Mechanicsburg, PA 17055 (US). WILLIAMS, Curt, Alan [US/US]; 10605 Dunhill Terrace, Raleigh, NC 27615 (US).</p> <p>(74) Agents: MEDWICK, George, M. et al.; E.I. du Pont de Nemours and Company, Legal/Patent Records Center, 1007 Market Street, Wilmington, DE 19898 (US).</p> <p>(81) Designated States: CA, JP, US, European patent (AT, BE, CH, DE, DK, ES, FR, GB, GR, IE, IT, LU, MC, NL, SE).</p> <p><b>Published</b> <i>With international search report.</i></p>	

## (54) Title: ZERO INSERTION FORCE CONNECTOR SYSTEM FOR A FLEXIBLE CIRCUIT



## (57) Abstract

A zero insertion force connector (16) includes a pair of spring clamp jaws (50A, 50B) each having a flexible circuit (12A, 12B) attached thereto. The clamp jaws are confrontationally arranged so that a portion of each clamp jaw adjacent to the rearward end thereof define a channel (98) through which the flexible circuits pass. Each flexible circuit (12A, 12B) is attached to a spring clamp jaw within a region on the circuit that is free of tracings (14A, 14B). An actuator (106A) provided within concave portions (99A, 99B) of each jaw to open the same and bring the conductive tracings into registration with the conductive tracings (C) on a substrate (B). Wiping action between the tracings is generated by engagement between an abutment surface (28A, 28B, 30A, 30B) on a fixture and a camming surface (124A, 124B) carried on the connector. A centering action to register the tracings is simultaneously generated.

*FOR THE PURPOSES OF INFORMATION ONLY*

Codes used to identify States party to the PCT on the front pages of pamphlets publishing international applications under the PCT.

AT	Austria	FR	France	MR	Mauritania
AU	Australia	GA	Gabon	MW	Malawi
BB	Barbados	GB	United Kingdom	NL	Netherlands
BE	Belgium	GN	Guinea	NO	Norway
BF	Burkina Faso	GR	Greece	NZ	New Zealand
BG	Bulgaria	HU	Hungary	PL	Poland
BJ	Benin	IE	Ireland	PT	Portugal
BR	Brazil	IT	Italy	RO	Romania
CA	Canada	JP	Japan	RU	Russian Federation
CF	Central African Republic	KP	Democratic People's Republic of Korea	SD	Sudan
CG	Congo	KR	Republic of Korea	SE	Sweden
CH	Switzerland	KZ	Kazakhstan	SK	Slovak Republic
CI	Côte d'Ivoire	LJ	Liechtenstein	SN	Senegal
CM	Cameroon	LK	Sri Lanka	SU	Soviet Union
CS	Czechoslovakia	LU	Luxembourg	TD	Chad
CZ	Czech Republic	MC	Monaco	TG	Togo
DE	Germany	MG	Madagascar	UA	Ukraine
DK	Denmark	ML	Mali	US	United States of America
ES	Spain	MN	Mongolia	VN	Viet Nam
FI	Finland				

TITLE  
ZERO INSERTION FORCE CONNECTOR SYSTEM FOR A FLEXIBLE  
CIRCUIT

BACKGROUND OF THE INVENTION

Field of the Invention The present invention relates to a connector system for a flexible circuit, and, in particular, to a zero insertion force connector system for interconnecting a flexible circuit to a substrate.

Description of the Prior Art In general, mechanical connector structures in the form of an insulated housing with individual spring contact beams cannot be effectively utilized when the desired spacing between the conductors to which interconnection is desired is less than 0.050 inches. For such circumstances it is believed necessary to utilize a flexible circuit arrangement.

A flexible circuit is an electrical conductor structure in which a base sheet of polyimide or polyester film material has conductive tracings photolithographed thereon. Suitable for use as the base sheet for such flexible circuit arrangement is the polyimide or polyester film material such as manufactured and sold by E. I. du Pont de Nemours & Co. under the trademarks "Kapton" or "Mylar", respectively.

Such a flexible circuit may be interconnected with either a conventional circuit board substrate or another flexible circuit using any one of a variety of known connector constructions. For example, the flexible circuit may be wrapped about a core and the core secured in proximity to a substrate in the manner disclosed and claimed in United States

Patent 4,552,420 (Eigenbrode), assigned to the assignee of the present invention.

5 In another implementation the member to which the flexible circuit is to be connected may be clamped between a pair of parallel beams. This arrangement is shown in United States Patent 4,647,125 (Landi et al.) and in the connector disclosed in United States Patent 4,690,472 (Elco et al.), assigned to the assignee of the present invention. This last-  
10 mentioned patent is also noteworthy for its disclosure of wedge-shaped positioning guides which align the conductive features of the circuits being interconnected.

As another alternative the end of the flexible circuit may  
15 be bent around a mantle or curved tongue and brought into sliding engagement with the member to which it is to be connected. Contact with the flexible circuit is made by spring members. The flexible circuit trails rearwardly from the connector. This arrangement is believed exemplified in the  
20 connectors disclosed in United States Patent 3,897,130 (Donnelley), United States Patent 3,941,448 (Evans), United States Patent 4,248,491 (Mouissie, also assigned to the assignee of the present invention), United States Patent 4,684,183 (Kinoshita et al.) or United States Patent 4,714,436 (Jones).

25 Still another form of flexible circuit connector utilizes a spring loaded clip arrangement in which the clips are opened to accept the end of the flexible circuit. When released the spring clips clamp the flexible circuit to the member to which it is to  
30 be interconnected. Representative of such connectors are those disclosed in United States Patent 4,111,510 (Zurcher) or United States Patent 4,252,389 (Olsson).

Yet another flexible circuit connector utilizes generally C-  
35 shaped spring clips in which the flexible circuit is brought to

the connector from the closed end of the C-shaped clip. The flexible circuit is looped around the arms of the clip and the ends of the flexible circuit enters between the open ends thereof. The connectors disclosed in United States Patent 5 3,614,707 (Zurcher), United States Patent 4,416,497 (Brandsness et al.), United States Patent 4,621,882 (Krumme), or Japanese Patent 3,069,171 (Fujitsu) are believed representative of this form of connector. Such an arrangement may be disadvantageous inasmuch as the looping of the flexible 10 circuit may engender stress in the conductive tracings thereon, leading to premature cracking of the material of the tracings.

#### SUMMARY OF THE INVENTION

15 The present invention relates to a zero insertion force connector and and a zero insertion force interconnection system for interconnecting conductive tracings on at least one, but preferably a pair, of flexible circuits to corresponding electrical conductive paths on respective surfaces of a 20 substrate.

The zero insertion force connector comprises a first and a second spring clamp jaw, each spring clamp jaw having a forward end and a rearward end thereon. Each flexible circuit 25 is attached to one of the clamp jaws adjacent the forward end thereof. The clamp jaws are confrontationally arranged so that a portion of each clamp jaw adjacent to the rearward end thereof cooperate to define a channel through which the flexible circuits pass. In the preferred case the flexible circuits 30 each have a region near the end thereof that is free of conductive tracings, and it is within this region that the flexible circuits are attached to the associated spring clamp jaw. Actuating means is provided for opening the spring clamp jaws to space the forward ends thereof apart a distance greater than 35 the thickness dimension of the substrate, thereby to permit the

conductive tracings on the flexible circuits into registration with the conductive paths on respective surfaces of the substrate.

5           Each of the spring clamp jaws has a concave portion intermediate the forward and the rearward ends thereof. The actuating means lies within the concave portion of the confrontationally arranged spring clamp jaws. In the preferred instance the actuating means comprises a first and a second  
10           actuator, with each actuator being respectively disposed within the concave portion of a respective one of the spring clamp jaws. Each actuator includes a bearing member having a bearing surface thereon, a rod rotationally received on the bearing surface, and an actuating handle for rotating the rod  
15           with respect to the bearing surface. Each rod has an actuating surface with an actuating edge defined thereon. Rotation of the rod by depressing the handles manually or with a remotely controlled device brings the actuating edge thereon into lifting engagement against the lifting surface on the concave portion  
20           of the spring clamp jaw within which it is disposed, thereby to impose an opening force on the spring clamp jaw to open the same against its spring bias. The opening of the spring clamp jaws urging the clamp jaws to the closed position. Preferably each of the actuating rods has a camming surface thereon.

25           The zero insertion force connector system additionally includes a fixture with respective upper and lower abutment edges thereon. In the preferred instance the fixture has a transition platform with conductive landings provided on both surfaces thereof. The landings are electrically connected to the  
30           conductive paths on respective surfaces of the substrate. In addition to generating the restoring force in the spring clamp jaws, rotation of the actuating rods presents the camming surface on each rod to the respective abutment edge on the fixture. When the connector is about to be joined to the fixture,  
35           the abutment edges on the fixture and the camming surfaces

on the rods are engaged such that a relative movement occurs therebetween in a rearward direction (i. e., toward the connector) in response to the restoring force in the spring jaws of the connector or to the restoring force provided by the  
5 remotely controlled device. This relative motion generates a wiping motion between the conductive landings on each surface of the transition platform of the fixture and the conductive tracings on each flexible circuit. The transition  
10 platform may be omitted, if desired, and the fixture attached directly to the substrate. In such an instance, the wiping action as above described is generated directly between the conductive paths on each surface of the substrate and the conductive tracings on each flexible circuit.

15 To insure registration between the tracings on the flexible circuits and the respective conductive landings on the transition platform (or the respective conductive paths on the substrate, if the fixture is omitted), both of the spring clamp  
20 jaws carry at least one positioning pin adjacent the forward end thereof. In addition, the fixture has an upper and a lower positioning ridge adjacent to each surface of the transition platform (or substrate, as the case may be). The positioning  
25 pin on each spring clamp jaw and its corresponding positioning ridge on the fixture are engageable to locate each spring clamp jaw with respect to the transition platform (or substrate) so that the conductive tracings on each flexible circuit register with the conductive landings (or conductive paths) on the  
30 corresponding surface of the transition platform (or substrate, as the case may be). Preferably, the positioning ridges are generally wedge-shaped, with the tip of the wedge pointing toward the spring clamp jaws and aligning with the rearward  
35 direction of the wiping motion. The positioning engagement between the positioning pins on the spring clamp jaws and the positioning ridges on the fixture occurs simultaneously with the generation of the wiping action.

BRIEF DESCRIPTION OF THE DRAWINGS

The invention will be more fully understood from the  
5 following detailed description thereof taken in connection with  
the accompanying drawings, which form a part of this  
application and in which:

Figure 1 is a perspective view of a zero insertion force  
10 connector system in accordance with the present invention for  
interconnecting conductive tracings on at least one flexible  
circuit to conductive paths on a substrate, with the clamping  
connector of the connector system about to be placed into  
operative association with a cooperating fixture secured to the  
15 substrate, portions of elements of the connector system being  
broken away for clarity of illustration;

Figure 2 is a sectional perspective view of the clamping  
connector of the zero insertion force flexible circuit connector  
20 system shown in Figure 1 taken along section lines 2-2 therein;

Figure 3A through Figure 3C are highly stylized pictorial  
representations illustrating steps during the mounting of the  
clamping connector to the cooperating fixture, these Figures  
25 particularly illustrating the generation of the wiping action  
between conductive tracings on the flexible circuit and  
conductive landings on the fixture; and,

Figure 4A through Figure 4C are highly stylized  
30 elevational (Figure 4A) or plan views (Figures 4B and 4C)  
respectively corresponding to Figures 3A through 3C,  
illustrating the registering action imparted by the interaction  
between positioning pins on the spring clamp jaws of the  
connector of the present invention and corresponding  
35 positioning ridges on the fixture, thereby to position the

conductive tracings on the flexible circuit and conductive landings on the fixture simultaneously with the generation of the wiping action.

5                    DETAILED DESCRIPTION OF THE INVENTION

Throughout the following detailed description similar reference numerals refer to similar elements in all figures of the drawings.

10

With reference to Figure 1 shown is a perspective view of a zero insertion force flexible circuit connector system generally indicated by the reference character 10 in accordance with the present invention. The connector system 10 is adapted to bring conductive tracings 14A disposed in a predetermined pattern on an operative surface of at least one flexible circuit 12A into electrical contact with conductive paths C disposed on a corresponding respective surface  $S_1$  of a substrate B, such as a rigid circuit board. It should be understood that although the substrate is shown in the Figures as a rigid circuit board, it lies within the contemplation of the invention for the substrate B to take the form of another flexible circuit. More preferably, the connector system 10 is adapted to bring conductive tracings 14A, 14B respectively disposed in a predetermined pattern on respective operative surfaces of each of a pair of flexible circuits 12A, 12B into electrical contact with conductive paths C disposed on a corresponding respective surfaces  $S_1, S_2$  of the substrate B. The board B has a thickness dimension T associated therewith. As is appreciated by those with skill in the art, the opposite surface 15A, 15B of one or both of the respective flexible circuits 12A, 12B may also have conductive traces (not shown) thereon which may, for example, carry ground currents. The ground traces can be connected through vias (not shown) to the traces 14A, 14B, respectively, on the first surfaces of the

flexible circuits 12A, 12B, respectively, or can be connected directly to the respective clamp jaws 50A, 50B.

5 The connector system 10 in accordance with this invention comprises a clamping connector member generally indicated by the reference character 16 and a cooperating fixture 18. The flexible circuits 12A (and 12B, if used) is(are) attached to the clamping connector 16 in a manner to be described, while the fixture 18 is attached to the substrate B.

10

In the most generalized embodiment, the fixture 18 includes a frame 20 supporting a transition platform 22. Preferably the frame 20 is a generally C-shaped member formed of a metallic material, although it may be fabricated from a suitable nonconductive material if desired. The frame 15 20 includes a main body portion 24 from which project extending arms 26A, 26B. The upper and lower surfaces of the end of the arm 26A are each provided with abutment surfaces 28A, 30A, while the upper and lower surfaces of the end of the 20 arm 26B is similarly provided with abutment surfaces 28B, 30B. As illustrated in the Figures the abutment surfaces 28A, 28B, 30A, 30B may be defined on inserts 32 secured to the arms 26A, 26B by any suitable expedient (such as the screws 34). Alternatively, however, the abutment surfaces 28A, 28B, 25 30A, 30B may be directly formed on the ends of the arms 26A, 26B. The purpose of the abutment surfaces 28A, 28B, 30A, 30B will become more clear herein. The confronting lateral surfaces of the arms 26A, 26B are provided with an upper pair of positioning ridges 36A, 36B. In the preferred instance the 30 arms 26A, 26B are similarly provided with a lower pair of positioning ridges 38A, 38B. The upper and lower pairs of positioning ridges are provided for a purpose to be later described.

In the preferred instance, the transition platform 22 is defined by the forward end region of the substrate B. In this event, the body portion 24 of the frame 20 is formed by upper and lower body sections 24A, 24B joined along a line of joinder  
5 24J and secured together by screws 39. Alternatively, the transition platform 22 may be formed from an insulated substrate member separate from the substrate B, in which event an integrally formed body portion 24 is slotted, as as 24S, whereby the substrate B may be edgewise engaged to the  
10 frame 20. Any suitable expedient may be used to secure the substrate B to the frame 20, with screws 39 again being illustrated for this purpose. The more general case in which the transition platform 22 is a member separate from the substrate B is discussed hereinafter.

15

The transition platform 22 is attached to the inner edge surfaces of the body 24 and of the arms 26A, 26B of the frame 20. When the transition platform 22 is formed of an insulating material, one or both of the surfaces 22S<sub>1</sub>, 22S<sub>2</sub> of the  
20 transition platform 22 is provided with conductive landings 42. The landings 42 may be arranged in any convenient pattern, with a two-row, staggered relationship being illustrated. The pattern of the landings 42 on the surfaces 22S<sub>1</sub>, 22S<sub>2</sub> of the transition platform 22 respectively matches the pattern of the  
25 tracings 14A, 14B on the flexible circuits 12A, 12B. The transition platform 22 has a thickness dimension 22T associated therewith.

The upper pair of positioning ridges 36A, 36B are  
30 adjacent to and communicate with the upper surface 22S<sub>1</sub> of the transition platform 22. Analogously, the lower pair of positioning ridges 38A, 38B are adjacent to and communicate with the lower surface 22S<sub>2</sub> of the transition platform 22. The ridges in each pair are arranged to lie in a generally wedge-  
35 like, or V-shaped, configuration, with the apex of the wedge

(i. e., the point of the V shape) being directed toward the clamping connector member 16.

To effect the interconnection of the landings 42 with the  
5 conductive paths C on the surface  $S_1$  of the substrate B at least  
a first array of spring contact fingers 44 extends rearwardly  
from the body 24 of the frame 20. The inward end of each of  
the spring contact fingers in the array 36 is disposed in  
electrical contact with a landing 42 on the first surface  $22S_1$  of  
10 the transition platform 22. Of course, in the preferred case,  
since landings 42 are also provided on the other surface  $22S_2$   
of the transition platform 22, a second array of spring contact  
fingers (not visible in the Figures) is provided to interconnect  
the landings 42 on the second surface  $22S_2$  of the transition  
15 platform 22 with the conductive paths on the second surface  $S_2$   
of the substrate B.

It should be noted that the transition platform 22 may be  
eliminated and the fixture 18 be directly mounted to the  
20 substrate B. In such an instance the resulting arrangement is  
generally similar to that shown in Figure 1, with a portion of  
the substrate B then being disposed between the arms 26 of  
the frame 20. The ridges 36A, 36B in the upper ridge pair  
would then lie adjacent to the upper surface  $S_1$  of the substrate  
25 B, while the ridges 38A, 38B in the lower ridge pair would then  
lie adjacent to the lower surface  $S_2$  of the substrate B. A  
suitable arrangement may be necessary to insulate the fixture  
18 from the conductive paths on the surfaces  $S_1$ ,  $S_2$  of the  
substrate B in the event the fixture is fabricated from a  
30 conductive material.

The clamping connector 16 is illustrated Figures 1 and 2.  
The clamping connector 16 is formed from a first, upper, and a  
second, lower, spring clamp jaw 50A, 50B, respectively. The  
35 clamp jaws are confrontationally disposed and are captured

between a pair of side plates 52A and 52B. Each side plate 52A, 52B has a window 54A, 54B formed therein. (The window 54B is not visible in Figure 2.) The upper edge of each of the side plates 52A, 52B is provided with a generally  
5 semicircular cutout 56A, 56B. A corresponding generally semicircular lower cutout 58A, 58B is provided in the lower edge of each of the side plates 52A, 52B. Again, owing to the perspective, the cutout 58A is not seen in Figures 1 and 2.

10 Generally speaking, in the preferred implementation each of the spring clamp jaws 50A, 50B has a first, forward, end 60A, 60B, respectively, and a second, rearward, end 62A, 62B respectively, thereon. Moreover, each of the spring clamp jaws 50A, 50B has a concave region 66A, 66B defined intermediate  
15 the respective forward ends 60A, 60B, and respective rearward ends 62A, 62B. The concave regions 66A, 66B are arranged in confrontational relationship with respect to each other.

More particularly, with reference to Figure 2, it may be  
20 seen that each spring clamp jaw 50A, 50B includes (beginning at the rearward end 62A, 62B thereof) a tail section (68A, 68B) bent at a line of bending (70A, 70B) from an adjacent linear section (72A, 72B). The linear section (72A, 72B) itself turns at a line of bending (74A, 74B) to form a linear backwall section  
25 (76A, 76B) that melds into a planar lifting wall section (78A, 78B). The backwall section (76A, 76B) and the lifting wall section (78A, 78B) together define the concave regions (66A, 66B) of the spring clamp jaws. The planar lifting wall section (78A, 78B) itself melds into a forward flange section (80A, 80B)  
30 that is terminated by a turned lip section (82A, 82B). The lip section (82A, 82B) lies at the forward edge 60A, 60B of the respective spring clamp jaws 50A, 50B. As noted earlier, if ground traces are provided on the opposite surface 15A, 15B of one or both of the flexible circuits 12A, 12B, such ground traces  
35 may be conveniently connected to the clamping jaw by direct

contact to the linear section 72A, 72B or a point near the forward end 60A, 60B of the respective jaw 50A, 50B.

5 The undersurfaces of the flange sections 80A, 80B of the spring clamp jaws 50A, 50B each receive an anvil 86A, 86B. The anvils are secured to their respective spring clamp jaw 50A, 50B by a screw 88. A brace bar 90A, 90B (Figure 2) is disposed between the one surface of each anvil 86A, 86B and the surface of the proximal flange sections 80A, 80B. The other  
10 surface of each anvil 86A, 86B is provided with load distributing elastomeric pad 92A, 92B. The ends of the anvils 86A, 86B extend laterally past the side edges of the spring clamp jaw 50A, 50B to which they are mounted, and thus laterally past the side edges of the spring clamp jaws 50A, 50B.

15 The laterally extending portion at each end of the anvil 86A has a respective positioning pin 94A, 94B thereon. Similarly, the laterally extending portion at each end of the anvil 86B has a positioning pin 95A, 95B. As will be developed,  
20 the positioning pins 94A, 94B interact with the upper pair of positioning ridges 36A, 36B to position the tracings 14A on the flexible circuit 12A with respect to the landings 42 on the surface 22S<sub>1</sub> of the transition platform 22 (if it is used) or, alternatively, with the conductive paths on the surface S<sub>1</sub> of  
25 the substrate B, if the platform 22 is omitted. In like manner, the positioning pins 95A, 95B are arranged to cooperate with the lower pair of positioning ridges 38A, 38B on the frame 20 of the fixture 18 thereby to position the tracings 14B on the flexible circuit 12B (if used) with respect to the landings 42 on  
30 the surface 22S<sub>2</sub> of the transition platform 22 (if present) or, alternatively, with the conductive paths on the surface S<sub>2</sub> of the substrate B.

In the assembled condition the spring clamp jaws 50A,  
35 50B of the clamping connector member 16 are arranged

between the side plates 52A, 52B. The confronting linear sections 72A, 72B of the spring clamp jaws 50A, 50B are spaced apart and thus cooperate to define a channel 98. The concave regions 66A, 66B are also confrontationally disposed, thereby to define an actuator receiving chamber 99A, 99B disposed beneath the respective spring clamp jaws 50A, 50B.

The spring clamp jaws 50A, 50B of the clamping connector member 16 are secured together by an upper and a lower transversely extending beam 100A, 100B. Each beam 100A, 100B lies between the exterior surface of the tail section 68A, 68B and the exterior surface of backwall section 76A, 76B of one its respective associated spring clamp jaw. When so positioned the jaws are held together by the action of each beam 100A, 100B acting against the exterior surface of the respective linear section 72A, 72B of one of the spring clamp jaws 50A, 50B. The ends of the beams 100A, 100B extend through the windows 54A, 54B in the side plates 52A, 52B. Adjacent lateral ends of the beams 100A, 100B are connected to each other by a post 102 at a point on the beams 100A, 100B just laterally past the end plates 52A, 52B, thus preventing the ends of the beams 100A, 100B from sliding out of the plates 52A, 52B. The beams may, alternatively, take the form of a U-shaped member, with one end of each of the tines of the member being integrally joined (and having exterior raised abutments to act against the lateral outside surface of one side plate). The other end of the tines are connected using a pin, similar to the arrangement shown in Figure 1.

Each of the flexible circuits 12A, 12B passes through the channel 98. The conductive tracings 14A, 14B on the respective flexible circuits 12A, 12B do not extend into a region 17A, 17B adjacent to the ends of the respective flexible circuits 12A, 12B. These end regions 17A, 17B of the respective flexible circuits 12A, 12B that are free of conductive tracings are attached to

the spring clamp jaws 50A, 50B, respectively. The end regions 17A, 17B preferably extend between and are captured by the undersurface of the jaws 50A, 50B and the confronting surface of the associated respective brace bar 90A, 90B. This  
5 arrangement is illustrated in Figure 2. However, as is illustrated in the Figures 3A through 3C and 4A, the end regions 17A, 17B should extend at least between the forward edge of the anvil 86A, 86B and the undersurface of the lip section 82A, 82B of each spring clamp jaws 50A, 50B. The  
10 point to note is that since the attachment of the flexible circuit to its respective jaw occurs in a region free of conductive tracings, damage to the tracings is not a consideration in a clamping connector in accordance with the present invention.

15 The clamping connector member 16 further includes actuating means 106, disposed in the actuator receiving chambers 99A, 99B provided respectively beneath the concave regions 66A, 66B of the jaws 50A, 50B, for opening the clamp jaws to space the forward ends 60A, 60B thereof apart a  
20 predetermined distance 108. In the implementation shown the distance 108 is measured between the tips of the positioning pins 94A, 94B (and, similarly, the the positioning pins 95A, 95B) and must be at least greater than the thickness dimension 22T of the transition platform 22. If the platform is omitted  
25 the distance 108, measured between the tips of the positioning pins 94A, 94B, must at least equal the thickness dimension T of the substrate B. Opening the jaws 50A, 50B also spaces apart the operative surfaces of the flexible circuits 12A, 12B in the vicinity of the forward end of the connector.

30

The actuating means 106 comprises a first and a second actuator 106A, 106B. The actuator 106A comprises a bearing block, or cradle, 110A having a generally cylindrically contoured bearing surface 112A thereon, a generally  
35 cylindrical elongated camming rod 114A, and an actuating

handle 116A attached to the camming rod 114A. The actuator 106B is similarly configured, and includes a bearing block, or cradle, 110B with a generally cylindrically contoured bearing surface 112B thereon, a generally cylindrical elongated camming rod 114B with an actuating handle 116B attached thereto.

Each bearing block 110A, 110B is respectively received in the chamber 99A, 99B beneath the respective concave region 66A, 66B of the spring clamp jaw 50A, 50B, as the case may be. Each block 110A, 110B is trapped between the rearward edge of the anvil 86A, 86B and the inner surface of the respective backwall section 76A, 76B of its associated spring clamp jaw. The bearing blocks 110A, 110B are laterally confined by the side plates 52A, 52B.

Each camming rod 114A, 114B is supported over the majority of its axial length by the bearing surface 112A, 112B on a respective one of the bearing blocks 110A, 110B. The lateral end of each camming rod 114A, 114B extends through the corresponding cutouts 56A, 58A and 58A, 58B in the side plates 52A, 52B. Each actuating handle 116A, 116B is connected to the ends of its associated camming rod 114A, 114B at points laterally past the side plates 52A, 52B.

As may be perhaps best seen in Figure 3A, each camming rod 114A, 114B has an axially extending notch 120A, 120B, respectively formed therein. The notches 120A, 120B are respectively defined by a generally planar surface 122A, 122B that communicates with a respective cam surface 124A, 124B. Further, the camming rods 114A, 114B are each provided with an axially extending lifting surface 126A, 126B each of which has a respective axially extending edge 127A, 127B. As will be seen the edges 127A, 127B define the operative portions of the respective lifting surfaces 126A, 126B. The lifting surface

126A, 126B matches the contour of the undersurface of the lifting wall section 78A, 78B of the spring clamp jaw 50A, 50B with which the camming rod 114A, 114B is associated. In the preferred embodiment illustrated the contour of lifting surface 5 126A, 126B and the undersurface of the lifting wall section 78A, 78B are both planar, although these surfaces may take other configurations and lie within the contemplation of the present invention.

10 Having described the structure of the connector system in accordance with the present invention, it is believed that the operation thereof may now be readily understood from the highly schematic side elevational and plan views shown in Figures 3A through 3C and Figures 4A through 4C.

15 In Figure 3A, respective movement of the actuating handles 116A, 116B in the directions 128A, 128B brings the edges 127A, 127B of the lifting surfaces 126A, 126B on the camming rods 114A, 114B, respectively, into lifting 20 engagement with the undersurface of the planar lifting wall section 78A, 78B of the clamp jaws 50A, 50B. Thus, the rotational motion of each camming rod 114A, 114B about its axis is converted a lifting action which opens the clamp jaws 50A, 50B against their spring bias and imparts opposed vertical 25 opening motions to the anvils 86A, 86B in the directions of the arrows 130A, 130B (Figure 1). The tips of the confronting pairs of positioning pins 94A, 95A and 94B, 95B respectively disposed on the anvils 86A, 86B, are thus spaced by at least the gap distance 108 (Figure 4A). The flexible circuits 12A, 12B 30 respectively attached to the jaws 50A, 50B are spaced apart as well.

As noted earlier, the required magnitude of the distance 108 depends upon the operational environment in which the 35 clamping connector member 16 is being used. In the event

that the clamping connector member 16 is being directly attached to a substrate B without the benefit of the fixture 18, or if the fixture 18 is being used without the transition platform 22, the distance 108 must at least equal the thickness dimension T of the substrate B (whether that substrate B is being implemented by a flexible circuit or a circuit board). However, when the clamping connector member 16 is being used with the cooperating fixture 18 having a transition platform 22 therein, the gap distance 108 must at least equal the thickness dimension 22T of the transition platform 22.

As may best be appreciated from Figures 3A and 3B, rotation of the rods 114A, 114B also has the effect of presenting a respective lateral end of the notch 120A on the rod 114A toward the upper abutment edges 28A, 28B (on the arms 26A, 26B, respectively) and a respective lateral end of the notch 114B toward the lower abutment edges 30A, 30B (on the arms 26A, 26B, respectively). The confrontation of the notch 120A, 120B with the surfaces 28A, 30A is illustrated in Figure 3B.

With the spring clamp jaws 50A, 50B still opened such that the confronting pairs of positioning pins 94A, 95A and 94B, 95B on the anvils 86A, 86B are spaced apart the gap distance 108, the connector 18 is advanced forwardly, in the direction of the arrow 134 (Figures 1, 3A, 3B, 4A, 4B), toward the transition platform 22. Forward advancement of the clamping connector member 16 toward the fixture 20 continues until the notches 120A, 120B on the camming rods 114A, 114B respectively engage against the upper camming edges 28A, 28B and the lower camming edges 30A, 30B (Figure 3B). In this disposition the tracings 14A, 14B on the flexible circuits 12A, 12B respectively vertically register with the landings 42 on the upper and lower surfaces 22S<sub>1</sub>, 22S<sub>2</sub> of the transition member 22. It should be readily appreciated that

such registration cannot be achieved unless the patterns of the tracings are matched. As will be more fully discussed hereinafter, at the time the engagement between the camming surfaces and the edges illustrated in Figure 3B is made, the upper and lower pairs of positioning pins on the spring clamp jaws have also been brought to a position where the pins lie within the confines of the wedge shaped configuration of the positioning ridges. This relationship is illustrated in Figure 4B for the case of the upper pair of positioning pins 94A, 94B and the upper positioning ridges 36A, 36B.

Release of the actuating handles 116A, 116B permits the restoring force due to the bias of the opened spring clamp jaws 50A, 50B to become dominant. The jaws close, in directions 132A, 132B (Figure 3C, these directions being counter to the opening directions 128A, 128B). The undersurfaces of the lifting wall sections 78A, 78B of the respective clamp jaws 50A, 50B act against the respective edges 127A, 127B of the lifting surfaces 126A, 126B on the rods 114A, 114B, causing the same to rotate about their axes. As the spring clamp jaws are closed, the tracings on the flexible circuit 12A, 12B are placed on the landings 42 on the respective surfaces 22S<sub>1</sub>, 22S<sub>2</sub> of the transition platform 22.

As may be seen in Figure 3C, the rotation of the camming rods 114A, 114B in these counter directions 132A, 132B brings the cam surface 124A on the rod 114A into operative engagement with the abutment edges 28A, 28B and the cam surface 124B on the rod 114B into operative engagement with the abutment edges 30A, 30B. The reaction between the cam surfaces and the abutment edges in response to the restoring force of the spring jaws imposes a force on the connector tending to move the same in the direction of the arrow 136, that is, in a direction rearwardly with respect to the connector 16. This motion of the clamping connector member 16 in the

direction 136 provides a wiping action in the direction 136 between the tracings 14A, 14B on the flexible circuits 12A, 12B and the corresponding landings 42 on the respective surfaces 22S<sub>1</sub>, 22S<sub>2</sub> of the transition platform 22.

5

The generation of the wiping action in the direction 136 has the simultaneous effect of self-aligning the tracings 14A, 14B on the flexible circuits 12A, 12B and the corresponding landings 42 on the respective surfaces 22S<sub>1</sub>, 22S<sub>2</sub> of the transition platform 22. The alignment is derived from the interaction between a pair of positioning pins on one of the anvils and the corresponding pair of positioning ridges on the fixture. As is best seen in Figure 4C, as the wiping action in the direction 136 is caused to occur, one of the positioning pins in the pair of pins 94A, 94B, (e. g., the pin 94A), is brought into abutting contact with one of the ridges 36A, 36B (e. g., the ridge 36A) in the upper ridge pair. As the pin moves in the wiping direction 136 and rides along the ridge 36A the constricting action imparted by the wedge shaped configuration of the ridges 36A, 36B serves to laterally shift the jaw 50A on which the pins 94A, 94B are disposed. Thus the appropriate ones of the tracings 14A on the flexible circuit 12A are caused to register with the corresponding landings 42 on the surface 22S<sub>1</sub> of the transition platform 22. A similar registering action is engendered on the lower surface 22S<sub>2</sub> of the platform 22, owing to the interaction between the pair of pins 95A, 95B and the ridges 38A, 38B in the lower ridge pair. It is, of course, to be understood that the same registering action between the positioning pins and the positioning ridges may occur in the event the platform 22 is omitted.

Those skilled in the art, having the teachings of the present invention as hereinabove set forth, may effect numerous modifications thereto. For example, it is again noted that the clamping connector member 16 may find utility when

only a single flexible circuit 12A is disposed on the clamping connector member 16. Further, also as noted earlier, the clamping connector member 16 may be used to directly connect tracings on one, or both, of the flexible circuit(s) directly to tracings on one, or both, surfaces of the substrate B. Moreover, if the fixture is used, thereby providing the benefits of the wiping action and the registering action discussed above, the fixture may be mounted directly to the substrate or may employ the transition platform, if desired. It should be appreciated that both the opening movement (i. e., in the direction 128) and/or the reverse movement of the actuating handles 116 (i. e., in the direction 132) may be imparted by a remotely controlled device, such as an air cylinder actuated from a remote location. This reverse movement of the actuating handles 116 may be used to cause the wiping action between the tracings discussed above. It should also be understood that these and such modifications lie within the contemplation of the present invention, as defined by the appended claims.

20

Figures 5A and 5B are perspective views illustrating the use of the connector system of the present invention in a board-to-board interconnection environment.

25 The connector system 10 of the present invention may also be used in an environment wherein one (or both) of the flexible circuits 12A, 12B is (are) themselves mounted to the surface of a rigid substrate (as a backplane or a motherboard) while the cooperating fixture 18 is attached to the board B (as a daughterboard). This board-to-board interconnection environment is illustrated in Figure 5A (although the flexible circuit 12B is not visible due to the perspective of Figure 5A). In Figure 5A the flexible circuit 12A is soldered or otherwise suitably affixed to pads (not shown) disposed on the surface of a second substrate B'. The flexible circuit(s) 12A (and 12B, if

35

provided) are attached to a clamping connector 16 in the manner discussed earlier herein. To facilitate this mounted disposition the extremities of the sideplates 52A, 52B of the clamping connector 16 are turned outwardly thereby to define mounting feet 53A, 53B. The feet 53A, 53B are suitably secured, as by respective screws 55A, 55B, to the substrate B'. The actuating handles 116A, 116B, are mounted in any convenient fashion to the respective ends of the camming rods 114A, 114B. Otherwise the structure and operation of the connector system 10 remains as discussed above.

The connector system 10 in accordance with this invention may also be used in a "ganged" fashion, as is illustrated in Figure 5B. In this arrangement an array of paired (or single) flexible circuits 12A, 12B are again affixed to pads on the surface of the second substrate B'. Each flexible circuit (or pair thereof) 12A (and 12B, if provided) is (are) attached to a corresponding clamping connector 16. The clamping connectors 16 are in turn mounted to the substrate B', using the mounting feet 53A, 53B defined by the out-turned ends of the sideplates 52A, 52B. The fixtures 18 associated with each clamping connector 16 are mounted to the board B. In this arrangement it may be desirable to orient the clamping connectors 16 on the substrate B' such that the camming rods 114A, 114B of each connector 16 may be connected in common, as in an end-to-end fashion. Alternately, the camming rod 114A, 114B may be defined by a unitary member. The actuating handle 116A, 116B of the respective common camming rods 114A, 114B are again conveniently positioned.

## WHAT IS CLAIMED IS:

1. A zero insertion force connector for interconnecting  
conductive tracings on at least a first flexible circuit to  
5 corresponding electrical conductive paths on a surface of a  
substrate, the substrate having a predetermined thickness  
dimension, the connector comprising:

10 a first and a second spring clamp jaw, each spring clamp  
jaw having a forward end and a rearward end thereon, the  
flexible circuit being attached to one of the clamp jaws adjacent  
to the forward end thereof, the clamp jaws being  
confrontationally arranged so that a portion of each clamp jaw  
adjacent to the rearward end thereof cooperate to define a  
15 channel through which the flexible circuit passes, and

actuating means for opening the spring clamp jaws to  
space apart the forward ends thereof.

20 2. The connector of claim 1 wherein the flexible circuit  
has an end thereon and wherein the conductive tracings on the  
flexible circuit terminate a predetermined distance from the  
end of the flexible circuit thereby to define on the flexible  
circuit a region that is free of conductive tracings, the flexible  
25 circuit being attached to the forward end of the one spring  
clamp jaw within the region on the flexible circuit that is free  
of conductive tracings.

30 3. The connector of claim 1 wherein each of the spring  
clamp jaws has a concave region intermediate the forward and  
the rearward ends thereof, and wherein the actuating means  
lies within the concave region of the confrontationally arranged  
spring clamp jaws.

4. The connector of claim 1 wherein each of the spring clamp jaws has a concave region intermediate the forward and the rearward ends thereof, the concave region of each jaw having a lifting surface thereon, and

5 wherein the actuating means comprises a first and a second actuator, each actuator being respectively disposed within the concave region of a respective one of the spring clamp jaws, each actuator comprising:

10 a bearing member having a bearing surface thereon,

a rod rotationally received on the bearing surface, the rod having an actuating surface with an actuating edge defined thereon, and

15 an actuating handle for rotating the rod with respect to the bearing surface to bring the actuating edge on the rod against the lifting surface on the concave region of the spring clamp jaw within which it is disposed thereby to impose an opening force on the spring clamp jaw to open the same against its spring

20 bias.

5. The connector of claim 4 wherein the rod is a generally cylindrical, and wherein the lifting surface on the concave region of each of the spring clamp jaws and the

25 actuating surface on each of the rods are generally planar.

6. The connector of claim 4 wherein at least one rod has a camming surface thereon,

30 the connector further comprising a fixture with an abutment edge thereon, the fixture having a transition platform with conductive landings thereon, the conductive landings being electrically connected to the conductive paths on the substrate

35 wherein rotation of the one rod to impose the opening force on its associated spring clamp jaw generates a restoring

force in the spring clamp jaw and simultaneously presents the camming surface on the rod to the abutment edge on the fixture,

5 the abutment edge and the camming surface being engageable such that relative movement therebetween in response to the restoring force in the spring clamp jaw generates a wiping motion acting in a predetermined wiping direction between the conductive landings on the fixture and the conductive tracings on the flexible circuit.

10

7. The connector of claim 6 wherein at least one spring clamp jaw has a positioning pin thereon, the positioning pin being disposed adjacent to the forward end thereof, and wherein the fixture has a positioning ridge thereon,

15

the positioning pin on the one spring clamp jaw and the positioning ridge on the fixture being engageable to locate the one spring clamp jaw with respect to the fixture so that the conductive tracings on the flexible circuit register with the conductive landings on the fixture.

20

8. The connector of claim 7 wherein positioning ridge on the fixture is generally wedge-shaped, with the closed end of the wedge aligning with the wiping direction and extending toward the connector.

25

9. The connector of claim 4 wherein at least one rod has a camming surface thereon,

the connector further comprising a fixture with an abutment edge thereon,

30

wherein rotation of the one rod to impose the opening force on its associated spring clamp jaw generates a restoring force in the spring clamp jaw and simultaneously presents the camming surface on the rod to the abutment edge on the fixture,

the abutment edge and the camming surface being engageable such that relative movement therebetween in response to the restoring force in the spring clamp jaw generates a wiping motion acting in a predetermined wiping direction between the conductive paths on the substrate and the conductive tracings on the flexible circuit.

10. The connector of claim 9 wherein at least one spring clamp jaw has a positioning pin thereon, the positioning pin being disposed adjacent to the forward end thereof, and wherein the fixture has a positioning ridge thereon, the positioning pin on the one spring clamp jaw and the positioning ridge on the fixture being engageable to locate the one spring clamp jaw with respect to the fixture so that the conductive tracings on the flexible circuit register with the conductive paths on the substrate.

11. The connector of claim 10 wherein positioning ridge on the fixture is generally wedge-shaped, with the closed end of the wedge aligning with the wiping direction and extending toward the connector.

12. The connector of claim 1 wherein at least one spring clamp jaw has a positioning pin thereon, the positioning pin being disposed adjacent to the forward end thereof, the connector further comprising a fixture attached to the substrate, the fixture having a positioning ridge thereon, the positioning pin on the one spring clamp jaw and the positioning ridge on the fixture being engageable to locate the one spring clamp jaw with respect to the fixture so that the conductive tracings on the flexible circuit register with the conductive paths on the substrate.

13. The connector of claim 12 wherein positioning ridge on the fixture is generally wedge-shaped, with the closed end of the wedge pointing toward the spring clamp jaws.

5 14. The connector of claim 1 wherein at least one spring clamp jaw has a positioning pin thereon, the positioning pin being disposed adjacent to the forward end thereof,  
the connector further comprising a fixture attached to the substrate, the fixture having a transition platform with  
10 conductive landings thereon, the conductive landings being electrically connected to the conductive paths on the substrate,  
the fixture also having a positioning ridge thereon,  
the positioning pin on the one spring clamp jaw and the  
15 one spring clamp jaw with respect to the fixture so that the conductive tracings on the flexible circuit register with the conductive landings on the transition platform.

15 15. The connector of claim 14 wherein positioning ridge on the fixture is generally wedge-shaped, with the closed end of the wedge pointing toward the spring clamp jaws.

20 16. A zero insertion force connector for interconnecting conductive tracings on each of a first and a second flexible circuit to corresponding electrical conductive paths on  
25 respective first and second surfaces of a substrate, the substrate having a predetermined thickness dimension, the connector comprising:

30 a first and a second spring clamp jaw, each spring clamp jaw having a forward end and a rearward end thereon, each of the flexible circuits being attached to a respective one of the clamp jaws adjacent to the forward end thereof, the clamp jaws being confrontationally arranged so that a portion of each

clamp jaw adjacent to the rearward end thereof cooperate to define a channel through which the flexible circuits pass, and

5           actuating means for opening the spring clamp jaws to space apart the forward ends thereof.

17. The connector of claim 16 wherein each flexible circuit has an end thereon and wherein the conductive tracings on each flexible circuit terminate a predetermined distance  
10 from the end thereof thereby to define on each flexible circuit a region that is free of conductive tracings, each flexible circuit being attached to the forward end of its respective spring clamp jaw within the region on the flexible circuit that is free of conductive tracings.

15

18. The connector of claim 16 wherein each of the spring clamp jaws has a concave region intermediate the forward and the rearward ends thereof, and wherein the actuating means lies within the concave region of the confrontationally arranged  
20 spring clamp jaws.

19. The connector of claim 16 wherein each of the spring clamp jaws has a concave region intermediate the forward and the rearward ends thereof, the concave region of each jaw  
25 having a lifting surface thereon, and

wherein the actuating means comprises a first and a second actuator, each actuator being respectively disposed within the concave region of a respective one of the spring clamp jaws, each actuator comprising:

30           a bearing member having a bearing surface thereon,

          a rod rotationally received on the bearing surface, the rod having an actuating surface with an actuating edge defined thereon, and

5 an actuating handle for rotating the rod with respect to the bearing surface to bring the actuating edge on the rod against the lifting surface on the concave portion of the spring clamp jaw within which it is disposed thereby to impose an opening force on the spring clamp jaw to open the same against its spring bias.

10 20. The connector of claim 19 wherein the rod is a generally cylindrical, and wherein the lifting surface on the concave region of each of the spring clamp jaws and the actuating surface on each of the rods are generally planar.

15 21. The connector of claim 19 wherein each rod has a camming surface thereon,  
the connector further comprising a fixture with first and a second abutment edge thereon, the fixture having a transition platform thereon, the transition platform having a first and a second surface, each surface of the transition platform having  
20 conductive landings thereon, the conductive landings on each respective surface of the transition platform being being electrically connected to the conductive paths on each respective surface of the substrate;

25 wherein rotation of the rod in each actuator to impose the opening force on its associated spring clamp jaw generates a restoring force in each of the spring clamp jaws and simultaneously presents the camming surface on each of the rods to one of the abutment edges on the fixture,

30 the abutment edges and the camming surfaces being engageable such that relative movement therebetween in response to the restoring force in the spring clamp jaws generates a wiping motion acting in a predetermined wiping direction between the conductive landings on the first and second surfaces of the transition platform of the fixture and the

conductive paths on respective first and second flexible circuits.

22. The connector of claim 21 wherein each spring clamp  
5 jaw has a positioning pin thereon, the positioning pin being  
disposed adjacent to the forward end of each spring clamp jaw,  
and wherein each of the first and second surface of the  
transition platform of the fixture has a positioning ridge  
thereon,

10 the positioning pin on each spring clamp jaw and the  
positioning ridge on respective surface of the transition  
platform of the fixture being engageable to locate the each  
spring clamp jaw with respect to the surface of the transition  
platform so that the conductive tracings on each flexible circuit  
15 register with the conductive landings on each respective  
surface of the transition platform.

23. The connector of claim 22 wherein positioning ridge  
on each surface of the transition platform is generally wedge-  
20 shaped, with the closed end of the wedge aligning with the  
wiping direction and extending toward the connector.

24. The connector of claim 19 wherein each rod has a  
camming surface thereon,  
25 the connector further comprising a fixture with first and  
a second abutment edge thereon,  
wherein rotation of the rod in each actuator to impose the  
opening force on its associated spring clamp jaw generates a  
restoring force in each of the spring clamp jaws and  
30 simultaneously presents the camming surface on each of the  
rods to one of the abutment edges on the fixture,  
the abutment edges and the camming surfaces being  
engageable such that relative movement therebetween in  
response to the restoring force in the spring clamp jaws  
35 generates a wiping motion acting in a predetermined wiping

direction between the conductive paths on the first and second surfaces of the substrate and the conductive tracings on the respective first and second flexible circuits.

5           25. The connector of claim 24 wherein each spring clamp  
jaw has a positioning pin thereon, the positioning pin being  
disposed adjacent to the forward end of each spring clamp jaw,  
and wherein the fixture has a first and a second positioning  
ridge thereon,  
10           the positioning pin on each spring clamp jaw and a  
respective one of the positioning ridges on the fixture being  
engageable to locate each spring clamp jaw with respect to the  
surface of the substrate so that the conductive tracings on each  
flexible circuit register with the conductive paths on each  
15           respective surface of the substrate.

26. The connector of claim 25 wherein each positioning  
ridge on the fixture is generally wedge-shaped, with the closed  
end of the wedge aligning with the wiping direction and  
20           extending toward the connector.

27. The connector of claim 16 wherein each spring clamp  
jaw has a positioning pin thereon, the positioning pin being  
disposed adjacent to the forward end of each spring clamp jaw,  
25           the connector further comprising a fixture, the fixture  
being attached to the substrate;  
            the fixture having a first and a second positioning ridge  
thereon,  
            the positioning pin on each spring clamp jaw and one of  
30           the positioning ridges on the fixture being engageable to locate  
the each spring clamp jaw with respect to a surface of the  
substrate so that the conductive tracings on each flexible circuit  
register with the conductive paths on each respective surface  
of the substrate.

35

28. The connector of claim 27 wherein positioning surface on each surface of the transition platform is generally wedge-shaped, with the closed end of the wedge pointing toward a respective spring clamp jaw.

5

29. The connector of claim 16 wherein each spring clamp jaw has a positioning pin thereon, the positioning pin being disposed adjacent to the forward end of each spring clamp jaw, the connector further comprising a fixture, the fixture having a transition platform thereon, the transition platform having a first and a second surface, each surface of the transition platform having conductive landings thereon, the conductive landings on each respective surface of the transition platform being electrically connected to the tracings on each respective surface of the substrate;

10  
15

each of the first and second surfaces of the transition platform of the fixture having a positioning surface thereon, the positioning pin on each spring clamp jaw and the positioning surface on each respective surface of the transition platform of the fixture being engageable to locate the each spring clamp jaw with respect to the surface of the transition platform so that the conductive tracings on each flexible circuit register with the conductive landings on each respective surface of the transition platform.

20  
25

30. The connector of claim 29 wherein positioning surface on each surface of the transition platform is generally wedge-shaped, with the closed end of the wedge pointing toward a respective spring clamp jaw.

30

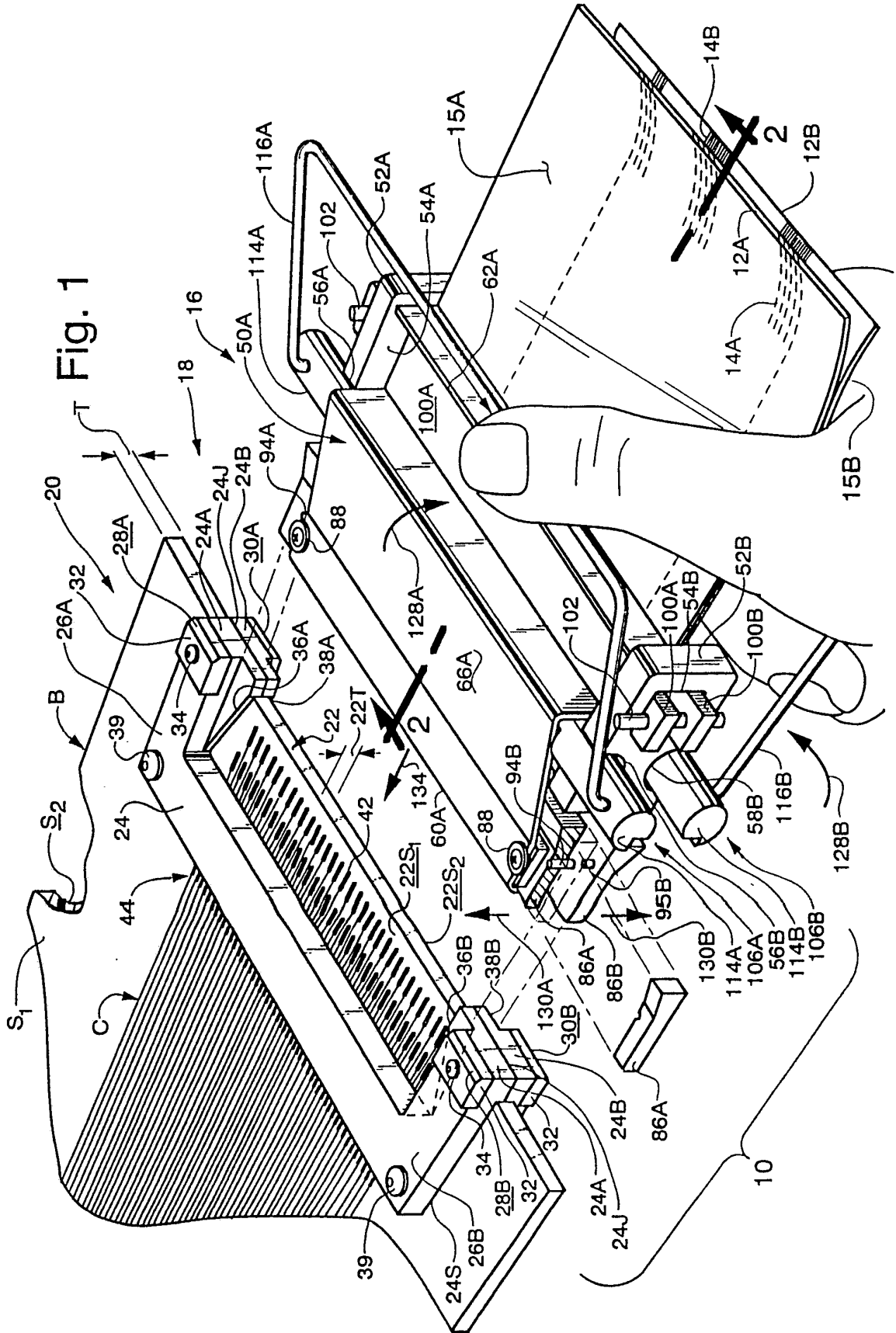

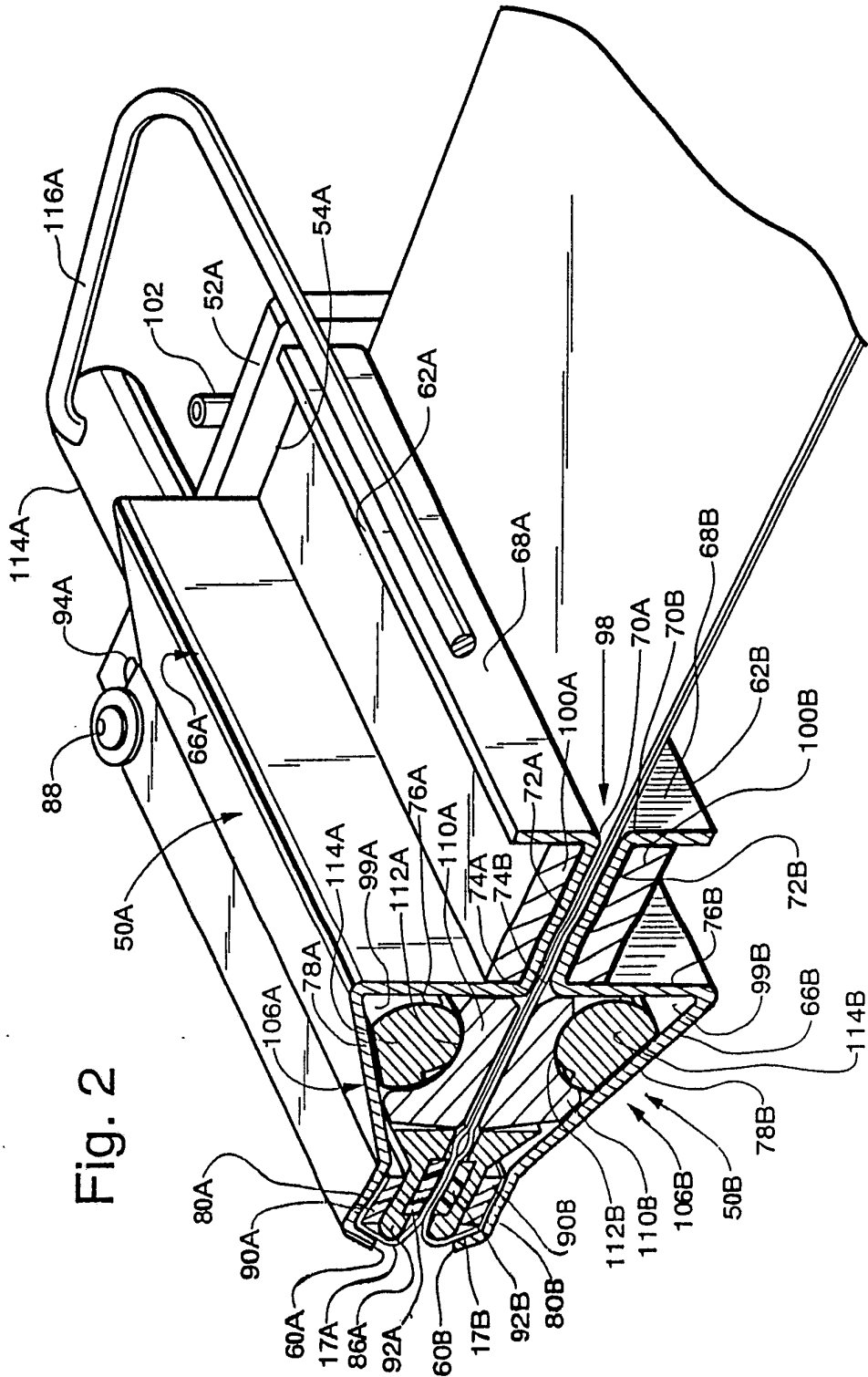

Fig. 2



Fig. 3B

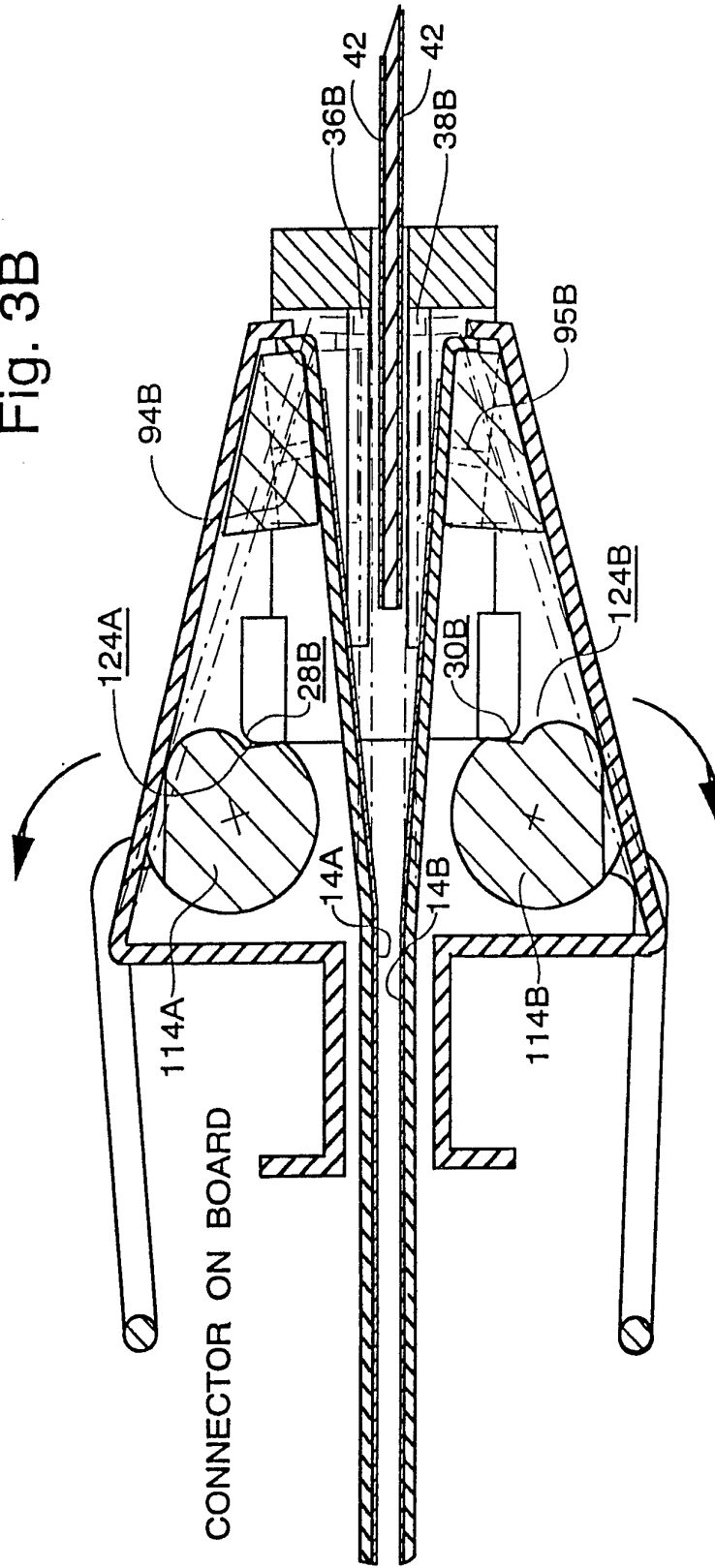

Fig. 3C

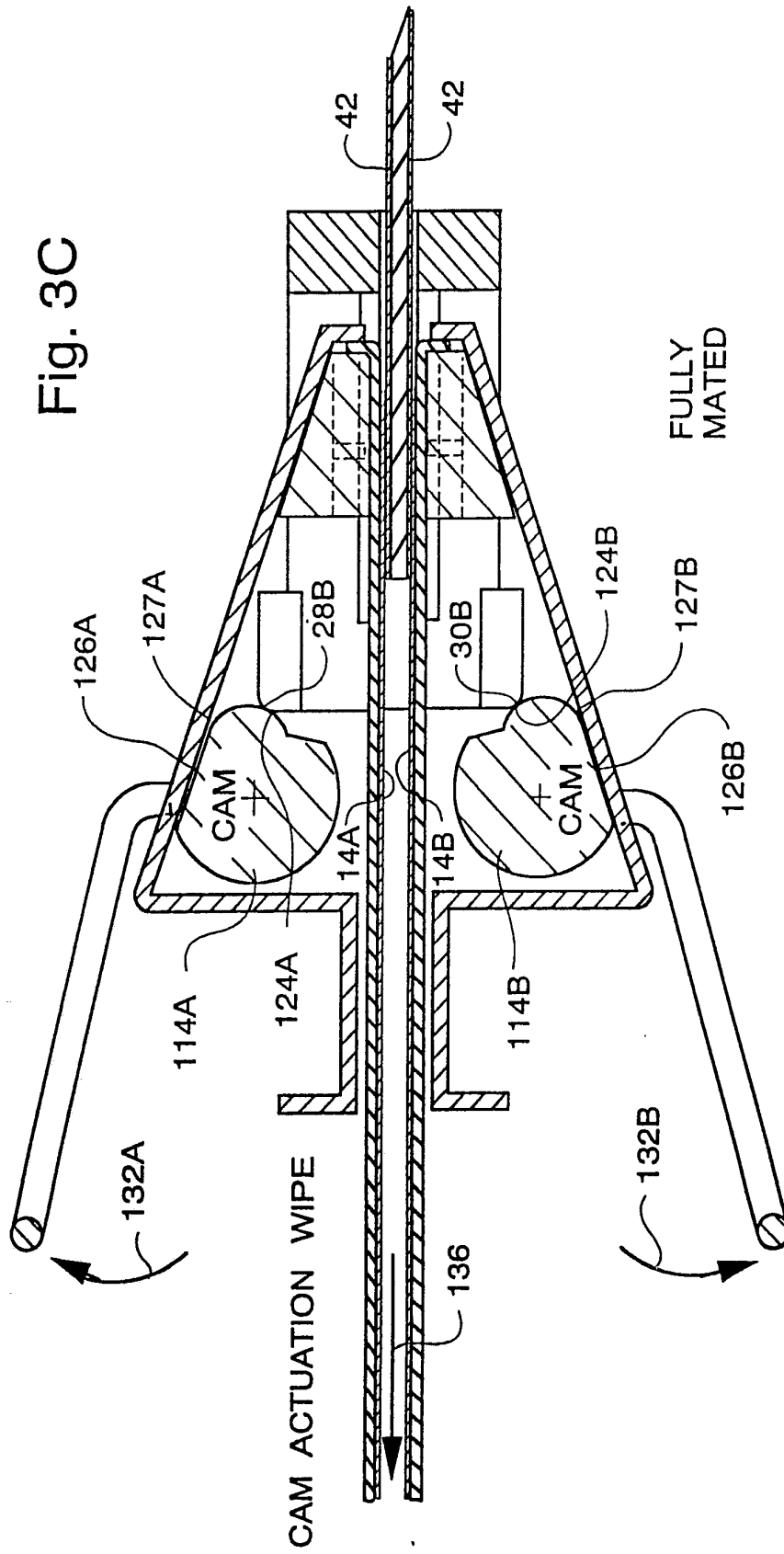

Fig. 4A

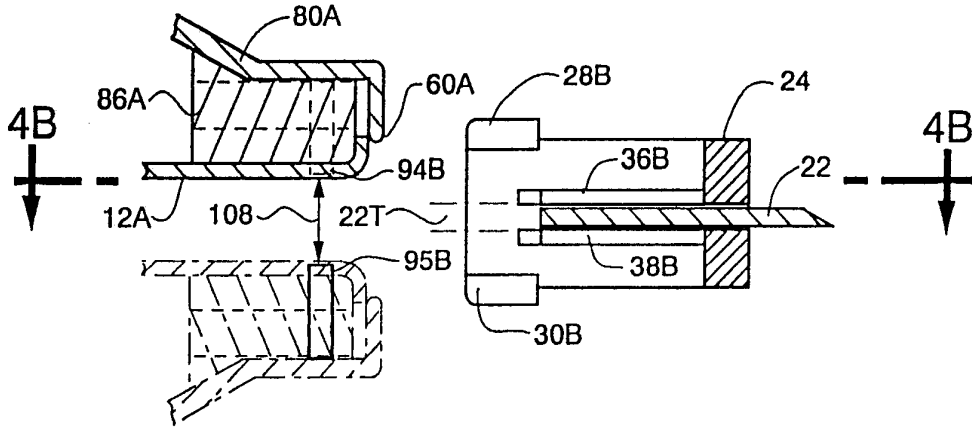

Fig. 4B

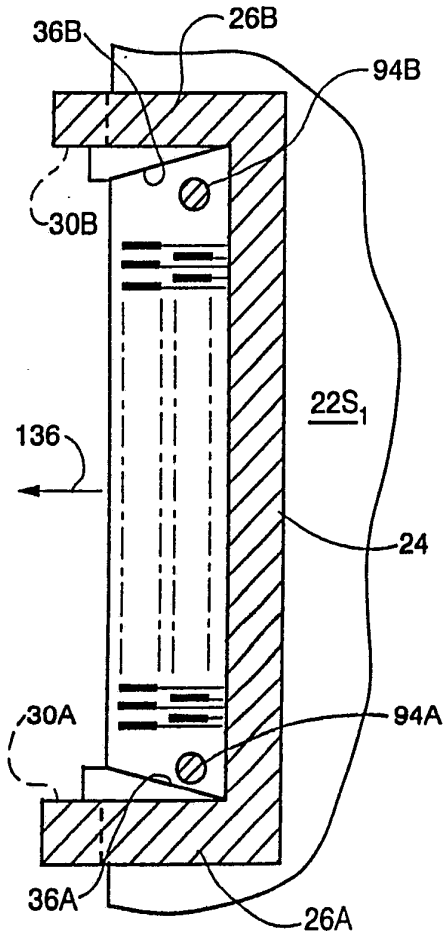
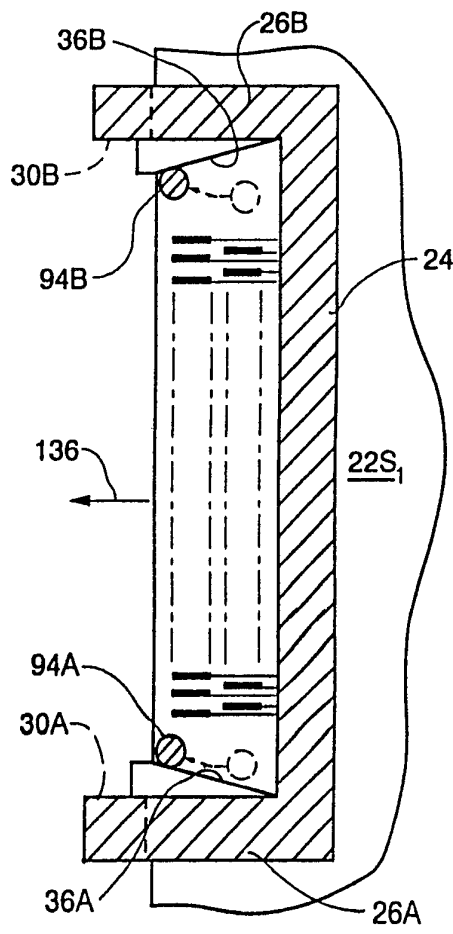

Fig. 4C



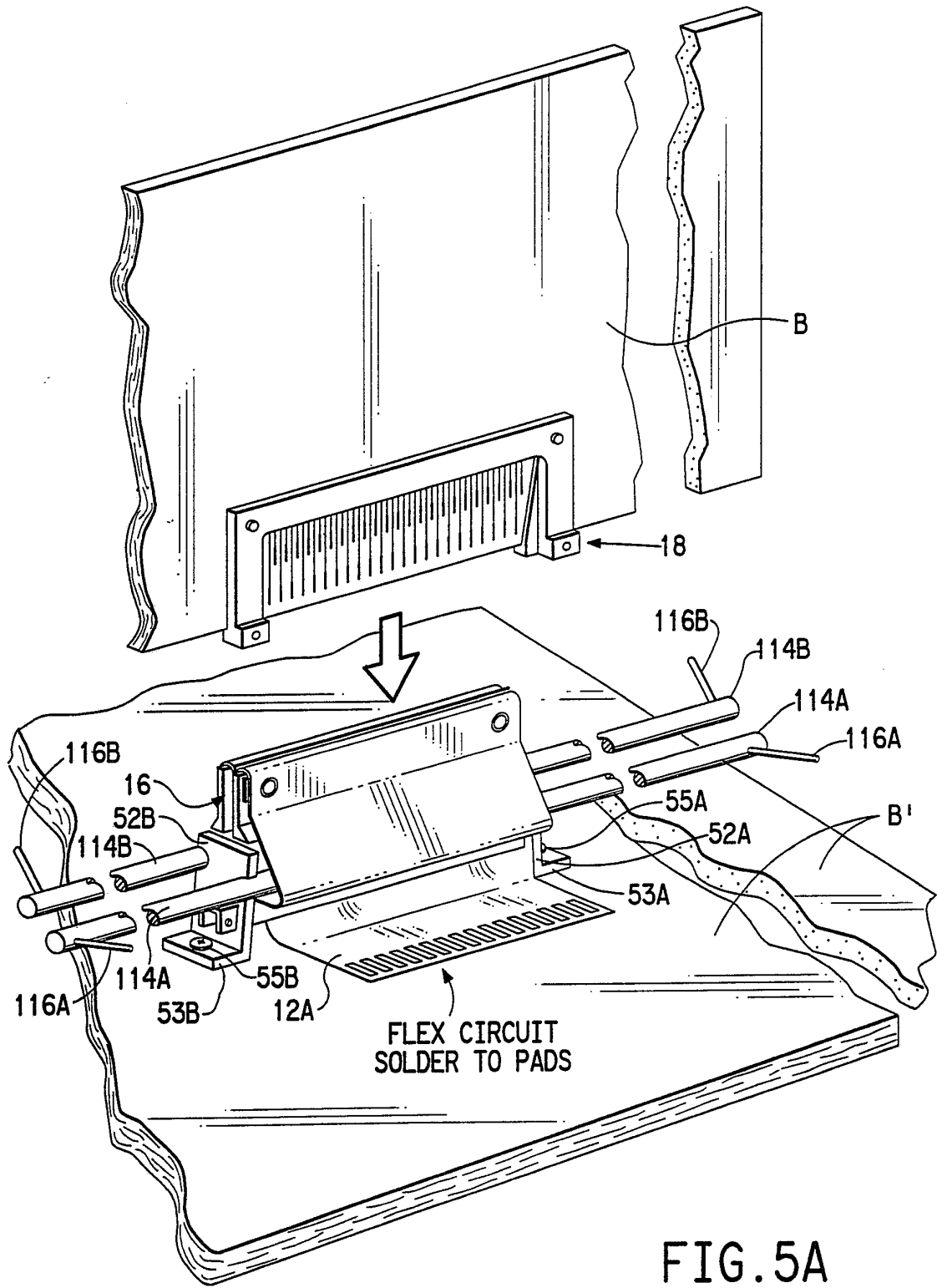

FIG. 5A

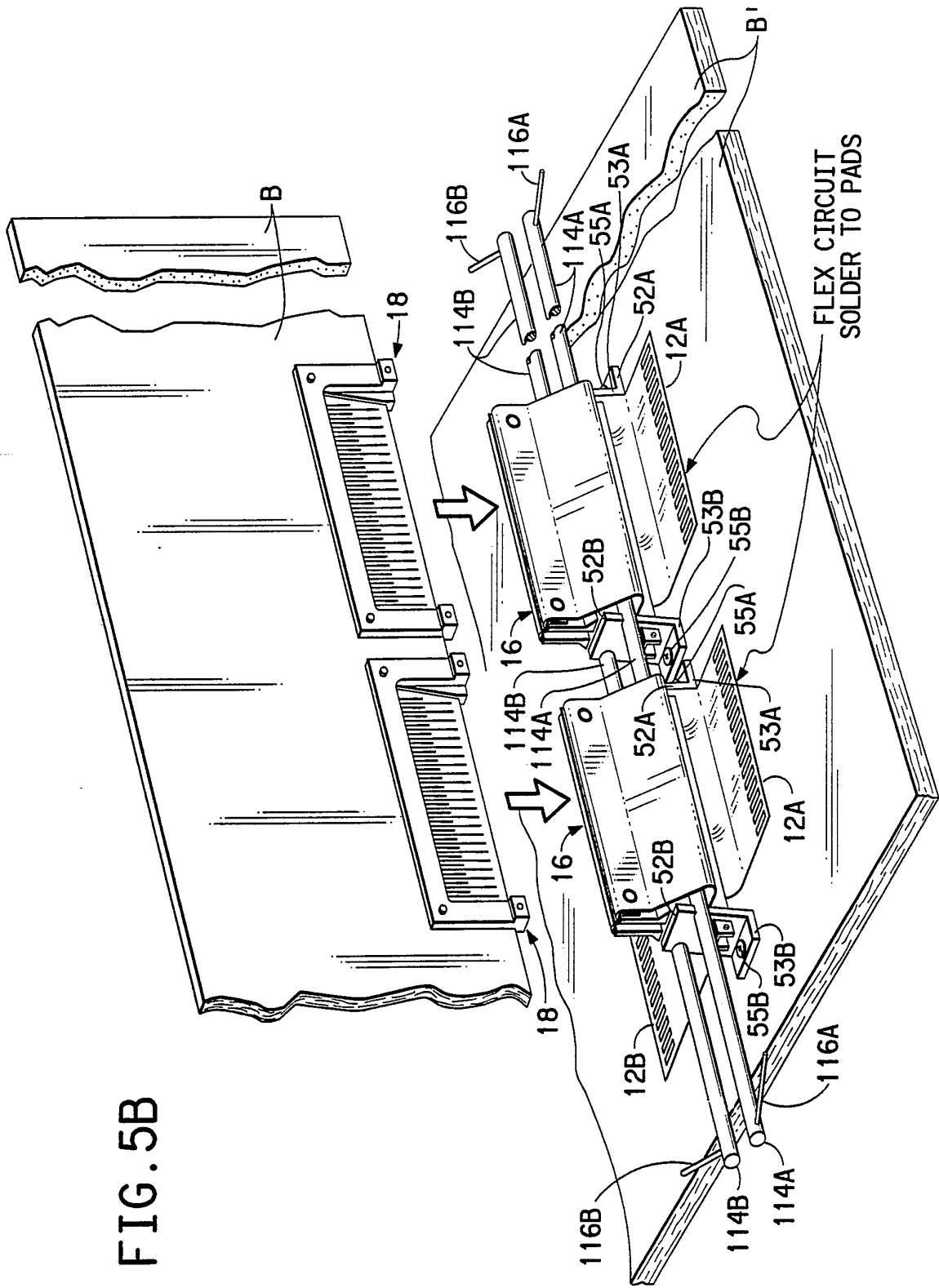

FIG. 5B

**INTERNATIONAL SEARCH REPORT**

PCT/US92/09987

**A. CLASSIFICATION OF SUBJECT MATTER**

IPC(5) :H01R 9/09,9/07,13/15,13/62,23/66,23/70

US CL :439/67,77,259-261,265,279,492,493,499,630,634-636

According to International Patent Classification (IPC) or to both national classification and IPC

**B. FIELDS SEARCHED**

Minimum documentation searched (classification system followed by classification symbols)

U.S. : 439/67, 77, 259-261, 265, 279, 492, 493, 499, 630, 634-636

Documentation searched other than minimum documentation to the extent that such documents are included in the fields searched

Electronic data base consulted during the international search (name of data base and, where practicable, search terms used)

**C. DOCUMENTS CONSIDERED TO BE RELEVANT**

Category*	Citation of document, with indication, where appropriate, of the relevant passages	Relevant to claim No.
A	US, A, 3,922,054 (DECHELETTE) 25 November 1975, See the entire document.	1-30
A	US, A, 4,798,541 (PORTER) 17 January 1989, See the entire document.	1-30
A	US, A, 4,850,883 (KABADI) 25 July 1989, See the entire document.	1-30
A	US, A, 4,871,315 (NOSCHESE) 03 October 1989, See the entire document.	1-30
A	US, A, 4,911,643 (PERRY ET AL.) 27 March 1990, See the entire document.	1-30

Further documents are listed in the continuation of Box C.  See patent family annex.

* Special categories of cited documents:	"T" later document published after the international filing date or priority date and not in conflict with the application but cited to understand the principle or theory underlying the invention
"A" document defining the general state of the art which is not considered to be part of particular relevance	"X" document of particular relevance; the claimed invention cannot be considered novel or cannot be considered to involve an inventive step when the document is taken alone
"E" earlier document published on or after the international filing date	"Y" document of particular relevance; the claimed invention cannot be considered to involve an inventive step when the document is combined with one or more other such documents, such combination being obvious to a person skilled in the art
"L" document which may throw doubts on priority claim(s) or which is cited to establish the publication date of another citation or other special reason (as specified)	"&" document member of the same patent family
"O" document referring to an oral disclosure, use, exhibition or other means	
"P" document published prior to the international filing date but later than the priority date claimed	

Date of the actual completion of the international search  
28 JANUARY 1993

Date of mailing of the international search report  
02 MAR 1993

Name and mailing address of the ISA/US  
Commissioner of Patents and Trademarks  
Box PCT  
Washington, D.C. 20231

Authorized officer

PAULA BRADLEY

Telephone No. (703) 308-1148

Facsimile No. NOT APPLICABLE

## INTERNATIONAL SEARCH REPORT

International application No.  
PCT/US92/09987

C (Continuation). DOCUMENTS CONSIDERED TO BE RELEVANT		
Category*	Citation of document, with indication, where appropriate, of the relevant passages	Relevant to claim No.
A	US, A, 4,917,613 (KABADI) 17 April 1990, See the entire document.	1-30
A	US, A, 4,934,942 (CASCIOTTI) 19 June 1990, See the entire document.	1-30
A	US, A, 4,938,702 (ENGLISH) 03 July 1990, See the entire document.	1-30
A	US, A, 4,969,824 (CASCIOTTI) 13 November 1990, See the entire document.	1-30
A	US, A, 5,044,980 (KRUMME ET AL.) 03 September 1991, See the entire document.	1-30
A	US, A, 5,047,895 (SASAKI) 10 September 1991, See the entire document.	1-30
A,P	US, A, 5,080,595 (MOUISSIE) 14 January 1992, See the entire document.	1-30
A,P	US, A, 5,102,343 (KNIGHT ET AL.) 07 April 1992, See the entire document.	1-30