



US00D596309S

(12) **United States Design Patent**  
**Tien et al.**

(10) **Patent No.:** **US D596,309 S**

(45) **Date of Patent:** **\*\* Jul. 14, 2009**

(54) **MAGNETIC STIRRER**

(76) Inventors: **Linsheng W. Tien**, 8 Arbusto, Irvine, CA (US) 92606; **Nick J. Manesis**, 2444 Camino de Jugar, San Ramon, CA (US) 94583; **Gene H. Huang**, 5131 Chateau Cir., Irvine, CA (US) 92604

(\*\*) Term: **14 Years**

(21) Appl. No.: **29/322,607**

(22) Filed: **Aug. 7, 2008**

(51) **LOC (9) Cl.** ..... **24-01**

(52) **U.S. Cl.** ..... **D24/220**

(58) **Field of Classification Search** ..... D24/216–226, D24/121; 422/99, 102; 366/243, 244, 247, 366/249, 251, 273, 274, 276–279

See application file for complete search history.

(56) **References Cited**

**U.S. PATENT DOCUMENTS**

- D231,981 S \* 7/1974 Paulsen ..... D24/219
- 3,850,580 A \* 11/1974 Moore et al. .... 422/99
- D343,904 S \* 2/1994 Silver et al. .... D24/219
- D358,659 S \* 5/1995 Rohrabacher ..... D24/220
- 5,934,179 A \* 8/1999 Schmid et al. .... 366/279
- 6,523,993 B2 \* 2/2003 Williams et al. .... 366/197
- D472,323 S \* 3/2003 Sand ..... D24/220
- 6,572,262 B1 \* 6/2003 Russel-Smith ..... 366/279
- D558,888 S \* 1/2008 Ware ..... D24/216

- D561,345 S \* 2/2008 Flick ..... D24/220
- D571,479 S \* 6/2008 Wagner ..... D24/220
- 7,396,153 B2 \* 7/2008 Andersson ..... 366/273

\* cited by examiner

*Primary Examiner*—T. Chase Nelson

*Assistant Examiner*—Anhdao Doan

(74) *Attorney, Agent, or Firm*—WPAT, P.C.; Anthony King

(57) **CLAIM**

The ornamental design for a magnetic stirrer set, as shown and described.

**DESCRIPTION**

The magnetic stirrer is typically used in a laboratory setting, and is placed inside of a beaker to stir liquid, or mixtures of liquid and solid. The magnetic stirrer comprises a main central body for enclosing a magnet within the main central body. The magnet within the main central body interacts with a magnetic stirrer plate, on which the beaker is placed. The magnetic stirrer plate causes the magnetic stirrer to spin inside of the beaker. The main central body of the magnetic stirrer is coupled with a plurality of protruding pieces.

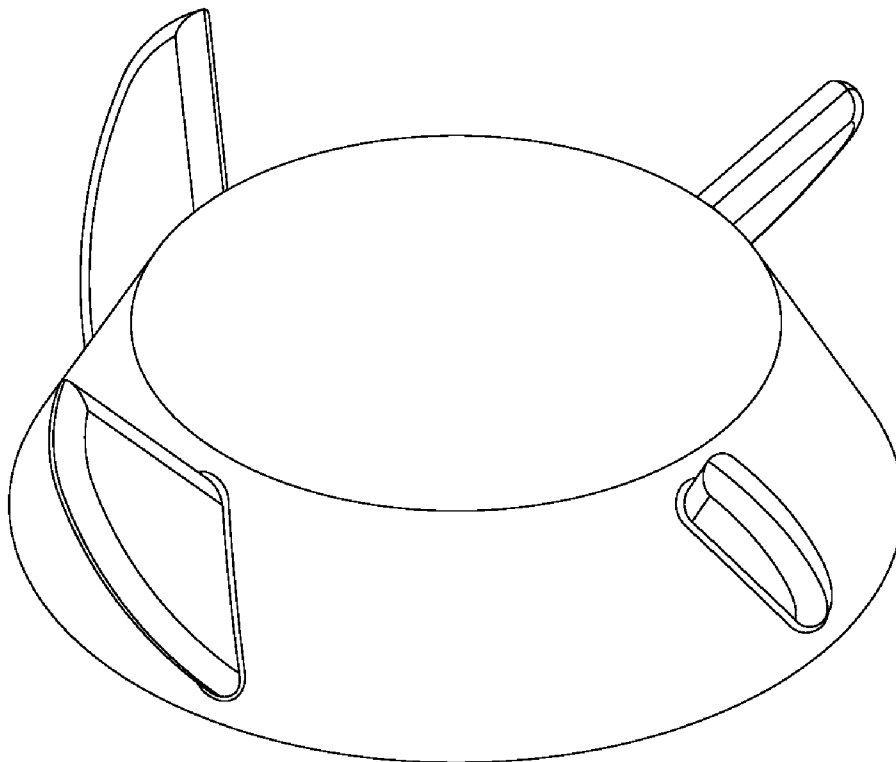
FIG. 1 is a top and side perspective view of a magnetic stirrer of the present invention;

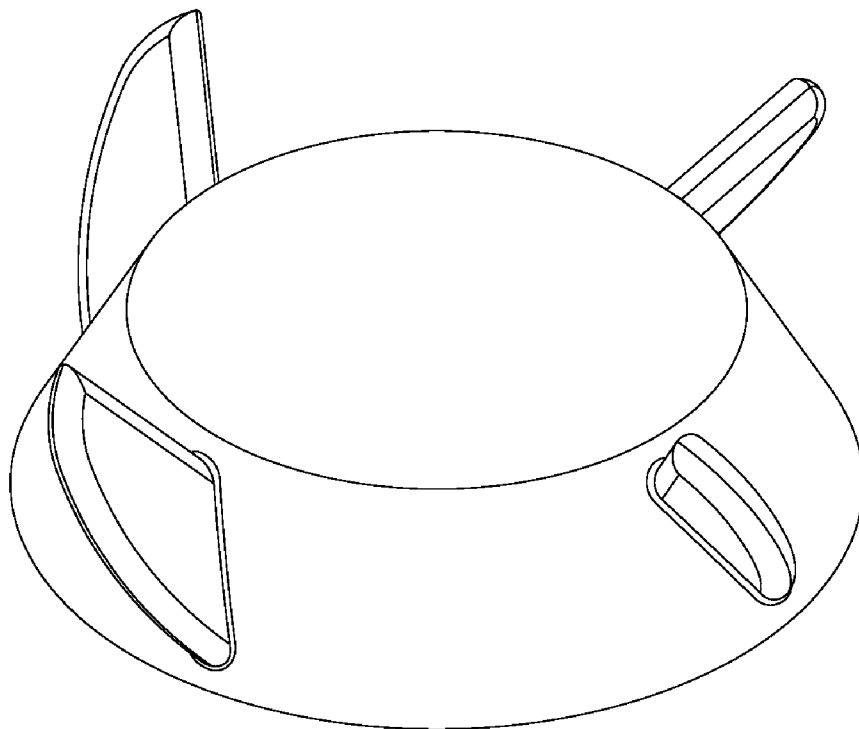
FIG. 2 is a side elevational view thereof;

FIG. 3 is a top plan view thereof; and,

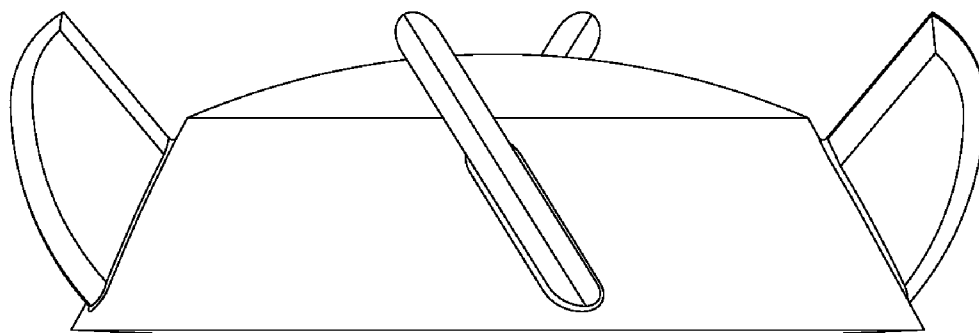
FIG. 4 is a bottom plan view thereof.

**1 Claim, 2 Drawing Sheets**

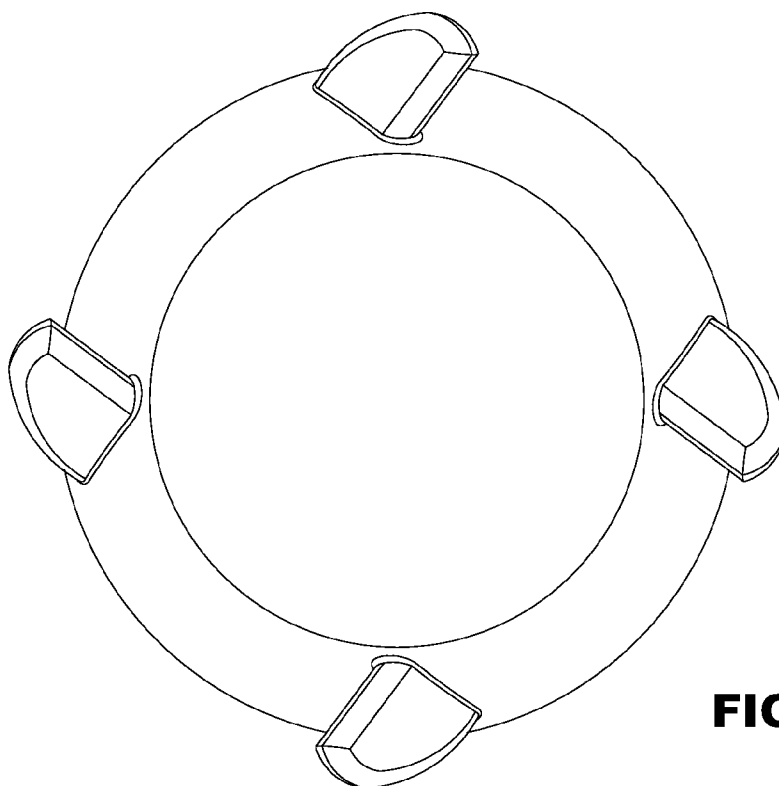




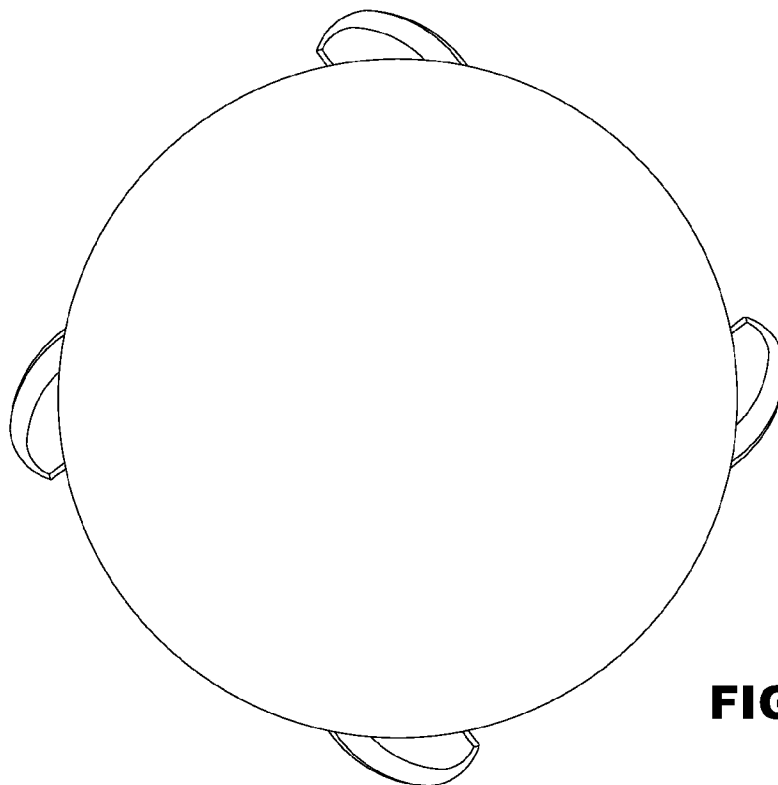
**FIG. 1**



**FIG. 2**



**FIG. 3**



**FIG. 4**