

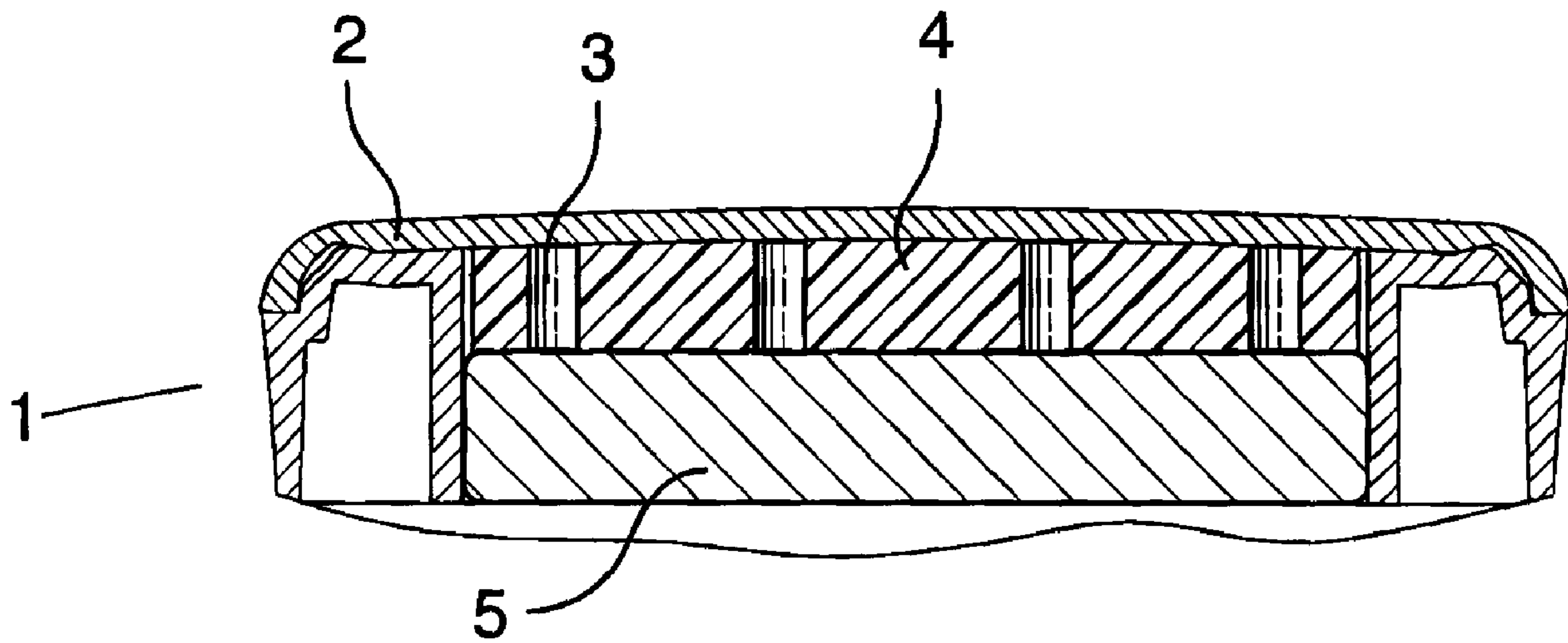

(22) Date de dépôt/Filing Date: 2006/08/25
 (41) Mise à la disp. pub./Open to Public Insp.: 2007/04/07
 (45) Date de délivrance/Issue Date: 2010/02/02
 (30) Priorité/Priority: 2005/10/07 (EP05109309.4)

(51) Cl.Int./Int.Cl. *H01M 2/10* (2006.01),
G06F 1/16 (2006.01), *H01M 2/02* (2006.01)
 (72) Inventeurs/Inventors:
LADOUCEUR, NORMAN M., CA;
GRIFFIN, JASON T., CA;
TYNESKI, FRANK, CA
 (73) Propriétaire/Owner:
RESEARCH IN MOTION LIMITED, CA
 (74) Agent: BORDEN LADNER GERVAIS LLP

(54) Titre : COMPARTIMENT DE BATTERIE A TAILLE ADAPTABLE POUR DISPOSITIFS ELECTRONIQUES
PORTATIFS
 (54) Title: EXPANDABLE BATTERY COMPARTMENT FOR HANDHELD ELECTRONIC DEVICES



(57) Abrégé/Abstract:
 In a portable electronic device having a battery compartment and a removable cover therefor, the battery compartment and cover are configured to accommodate batteries of at least two different sizes.

ABSTRACT

In a portable electronic device having a battery compartment and a removable cover therefor, the battery compartment and cover are configured to
5 accommodate batteries of at least two different sizes.

EXPANDABLE BATTERY COMPARTMENT
FOR HANDHELD ELECTRONIC DEVICES

BACKGROUND OF THE INVENTION

5 This invention relates to portable electronic devices, including but not limited to handheld wireless communication devices. More particularly, this invention relates to means of accommodating batteries of different sizes in such devices.

Certain portable electronic devices, handheld wireless communication devices in particular, are designed to provide various battery life options, depending on different capacity batteries being used. Batteries of different capacity tend to have different physical dimensions. These differences in dimension are typically compensated for by providing battery area access doors of varying dimension, i.e. a separate battery door for each possible battery. It would be preferable to avoid such separate battery doors.

15 **SUMMARY OF THE INVENTION**

The invention therefore provides various means for accommodating batteries of different dimensions, without requiring separate battery doors.

Reference will be made to “relatively thin” batteries, and “somewhat thicker” batteries. It should be understood that “relatively thin” means relative to the thickness of the “somewhat thicker” batteries, and is not intended to indicate that the “relatively thin” battery is in fact thin compared to batteries in general.

In the invention, a portable electronic device having a battery compartment and a removable cover therefor, has the battery compartment and cover being configured to accommodate batteries of at least two different sizes.

25 According to one exemplary embodiment, the cover has at least one elastomeric element beneath it to bear against an installed battery, the elastomeric element(s) being compressible from a position adapted to

accommodate a relatively thin battery, to a position where a somewhat thicker battery can be accommodated.

According to another exemplary embodiment, for the cover has a generally rigid outer frame and a generally rigid centre portion, the outer frame and
5 centre portion being connected by an elastomeric web portion whereby the centre portion may be displaced outwardly to accommodate a somewhat thicker battery.

According to yet another exemplary embodiment, the cover has a generally rigid outer frame and an elastomeric centre portion secured to the outer
10 frame, whereby the centre portion may be displaced outwardly to accommodate a somewhat thicker battery.

According to yet another exemplary embodiment, the cover has an outer surface and side walls configured to encompass an installed battery, the side
15 walls having flexible engagement means extending outwardly therefrom, to engage recesses in said battery compartment, the recesses being provided at at least two relative heights.

According to yet another exemplary embodiment, the cover has an outer surface and side walls configured to encompass an installed battery, the
20 battery compartment having flexible engagement means extending inwardly therefrom, to engage recesses in the battery cover side walls, the recesses being provided at at least two relative heights.

According to yet another exemplary embodiment, the cover has a generally rigid outer frame and a generally rigid centre portion, the outer frame and
25 centre portion being connected by a springy material biasing the centre portion to a position to accommodate a relatively thin battery, the centre portion being displaceable outwardly to accommodate a somewhat thicker battery.

According to yet another exemplary embodiment, the cover has a generally rigid outer frame and a generally rigid centre portion securable to the outer

frame in either one of at least two positions, each position corresponding to a different battery thickness.

The invention contemplates batteries not only of discrete sizes, but in at least some embodiments, sizes which may vary along a continuum of sizes.

- 5 Aspects of the invention will be described or will become apparent in the course of the following detailed description and drawings of specific embodiments of the invention, as examples only.

BRIEF DESCRIPTION OF THE DRAWINGS

Embodiments of the invention will now be described, by way of example only,
10 with reference to the attached drawings, in which:

Fig. 1 is a perspective view of a first exemplary embodiment;

Fig. 2 is a cross-sectional elevation view of the first embodiment, with a relatively thin battery;

15 Fig. 3 is a cross-sectional elevation view of the first embodiment, with a somewhat thicker battery;

Fig. 4 is a perspective view of a second embodiment, with a relatively thin battery;

Fig. 5 is another perspective view of the second embodiment, with a somewhat thicker battery;

20 Fig. 6 is a cross-sectional elevation view of the second embodiment, with a relatively thin battery;

Fig. 7 is a cross-sectional elevation view of the second embodiment, with a somewhat thicker battery;

25 Fig. 8 is a perspective view of a third embodiment, with a relatively thin battery;

Fig. 9 is another perspective view of the third embodiment, with a somewhat thicker battery;

Fig. 10 is a cross-sectional elevation view of the third embodiment, with a relatively thin battery;

5 Fig. 11 is a cross-sectional elevation view of the third embodiment, with a somewhat thicker battery;

Fig. 12 is a perspective view of a fourth embodiment;

Fig. 13 is a cross-sectional elevation view of the fourth embodiment, with a relatively thin battery;

10 Fig. 14 is a cross-sectional elevation view of the fourth embodiment, with a somewhat thicker battery;

Fig. 15 is a perspective view of a fifth embodiment, with a relatively thin battery;

15 Fig. 16 is another perspective view of the fifth embodiment, with a somewhat thicker battery;

Fig. 17 is a cross-sectional elevation view of the fifth embodiment, with a relatively thin battery;

Fig. 18 is a cross-sectional elevation view of the fifth embodiment, with a somewhat thicker battery;

20 Fig. 19 is a cross-sectional elevation view of a sixth embodiment, similar to the fifth embodiment, with a relatively thin battery;

Fig. 20 is a cross-sectional elevation view of the sixth embodiment, with a somewhat thicker battery;

Fig. 21 is a perspective view of a seventh embodiment;

25 Fig. 22 is a cross-sectional elevation view of a portion of the seventh embodiment;

Fig. 23 is a cross-sectional elevation view of the seventh embodiment, with a relatively thin battery;

Fig. 24 is a cross-sectional elevation view of the seventh embodiment, with a somewhat thicker battery;

5 Fig. 25 is a cross-sectional elevation view of an eighth embodiment, with a relatively thin battery;

Fig. 26 is a cross-sectional elevation view of a portion of the cover of the eighth embodiment;

10 Fig. 27 is a cross-sectional elevation view of the eighth embodiment, with a somewhat thicker battery;

Fig. 28 is a perspective view of the battery cover of a ninth embodiment, in a position for a relatively thin battery;

Fig. 29 is a cross-sectional elevation view the cover, corresponding to Fig. 28;

15 Fig. 30 is a perspective view of the battery cover of the ninth embodiment, in a position for a somewhat thicker battery; and

Fig. 31 is a cross-sectional elevation view the cover, corresponding to Fig. 30.

DETAILED DESCRIPTION OF THE INVENTION

The accompanying drawings illustrate various aspects and exemplary embodiments to accommodate batteries of different sizes.

20 According to a first exemplary embodiment, as shown in Figs. 1-3, the handheld device 1 with a cover 2 secured to the device by any suitable conventional means, over a battery compartment 3. Inside the battery compartment, under the cover, are one or more elastomeric elements 4 which bear against an installed battery, 5 or 5'. Fig. 2 shows a relatively thin battery
25 5, such that the elastomeric elements are not compressed, or are compressed only sufficiently to keep the battery in position. Fig. 3 shows a somewhat thicker battery 5', such that the elastomeric elements are somewhat

compressed, the compression creating more space to accommodate the larger battery.

According to a second exemplary embodiment, as shown in Figs. 4-7, the handheld device 1 has a cover 2 secured to the device by any suitable conventional means, over the battery compartment 3. The cover has a generally rigid outer frame 6, for example of hard plastic or metal, and a generally rigid centre portion 7, again for example of hard plastic or metal. The outer frame and centre portion are connected by an elastomeric web portion 8, molded with or otherwise connected to both the outer frame and the centre portion. As can be seen from a comparison between Figs. 4 and 5, or especially between Figs. 6 and 7, the centre portion 7 is in one position in Figs. 4 and 6, relatively flat or generally co-planar with the outer frame 6 for example, to accommodate a relatively thin battery 5. In Figs. 5 and 7, the elastomeric web 8 is stretched, and the centre portion 7 is displaced outwardly, thereby accommodating a somewhat thicker battery 5'.

A third exemplary embodiment, similar to the second embodiment, is shown in Figs. 8-11. In this embodiment, there is no generally rigid centre portion. Instead, there is an elastomeric portion 9 secured to the outer frame 6, spanning across the battery compartment. As can be seen from a comparison between Figs. 8 and 9, or especially between Figs. 10 and 11, the elastomeric portion 9 is in one position in Figs. 8 and 10, relatively flat or generally co-planar with the outer frame 6 for example, to accommodate a relatively thin battery 5. In Figs. 9 and 11, the elastomeric portion 9 is stretched, particularly towards outer edges thereof, thereby accommodating a somewhat thicker battery 5'.

A fourth exemplary embodiment, also similar to the second embodiment, is shown in Figs. 12-14. In this embodiment, the cover again has a generally rigid outer frame 6 and a generally rigid centre portion 7, and the outer frame and centre portion are again connected by an elastomeric web portion. However, the elastomeric web portion 8', is in the form of a flexible membrane, molded with or otherwise connected to both the outer frame and the centre portion. The membrane tucks into a small gap 10 between the

battery 5 or 5' and the side wall 11 of the battery compartment. As with the previous embodiments, Figs. 13 and 14 show the comparison between accommodating a relatively thin battery 5 and a somewhat thicker battery 5'.

A fifth exemplary embodiment is shown in Figs. 15-18. In this embodiment, a battery cover 12 has an outer surface 13 and side walls 14 encompassing the battery 5 or 5'. The battery cover preferably is generally rigid, but could be somewhat flexible. Extending outwardly from the side walls 14 are flexible engagement means 15 such as elastomeric or otherwise flexible tabs or a flange, which can engage corresponding recesses 16 or 16' at two or more relative heights. The battery cover is installed by pressing it downwardly into the battery compartment, such that the flexible engagement means snap or pop into the relevant recess or recesses. One recess height, shown in Fig. 17, corresponds to a relatively thin battery 5, while the other recess height, shown in Fig. 18, corresponds to a somewhat thicker battery 5'. There could be additional recess heights if desired. The flexible engagement means 15 could be tabs placed at several locations around the circumference of the battery cover, with recesses at corresponding locations, or could be in the form of a continuous flange extending all the way around the battery cover. The tabs or flange could be integral to the battery cover, or could be a separate piece. Although elastomeric tabs or an elastomeric flange are primarily contemplated, it should be appreciated that analogous means could be employed instead. For example, the battery cover could be provided with a ball-spring arrangement, to engage detents at different heights in the battery compartment, or the reverse could be provided, i.e. ball-spring arrangements in the battery compartment, engaging detents in the side walls of the battery cover.

Figs. 19 and 20 show a sixth exemplary embodiment, very similar to the preceding embodiment, in which the flexible engagement means 15' is in the form of elastomeric dimples engaging corresponding recesses. The ball-spring arrangement referred to above would be somewhat similar in concept and appearance.

Figs. 21-24 show a seventh exemplary embodiment, similar in concept to the second and fourth embodiments in particular. In this embodiment, the cover has a generally rigid outer frame **6**, for example of hard plastic or metal, and a generally rigid centre portion **7'**, again for example of hard plastic or metal.

5 The outer frame and centre portion are connected by a web portion **8'**, molded with or otherwise connected to both the outer frame and the centre portion. This web portion **8'** is of a springy material, biased to the position shown in Fig. 23. To accommodate a somewhat thicker battery **5'**, the web portion **8'** expands outwardly as shown in Fig. 24.

10 Figs. 25-27 show an eighth exemplary embodiment, in which the battery cover **20** itself, or a portion thereof, is reversible and has tabs or flanges **21** displaced from the centreline. As can be seen from comparing Figs. 25 and 27, flipping the cover or cover portion thus creates a smaller or larger space for the battery **5** or **5'**.

15 Figs. 28-31 show a ninth exemplary embodiment, in which the battery cover **2** is in two pieces, namely an outer frame **24**, and a central portion **25**. As can be readily seen from the drawings, the centre portion can be installed in one of two positions, according to a principle somewhat similar to the preceding embodiment. Depending on which orientation is used, a smaller or larger
20 space for the battery **5** or **5'** is created.

The preceding embodiments illustrate various aspects of the invention, but as examples only. It will be appreciated that many additional variations and examples are possible, and will be apparent to those knowledgeable in the field of the invention. Thus the scope of the invention, as defined in the
25 following claims, is not limited to these specific examples.

Without limiting the generality of the foregoing, further aspects may include, for example, any other obvious variations as to how the battery cover may be configured or installed to provide varying battery compartment sizes; any obvious variations in choices of materials, degree of flexibility or resilience, if
30 any, and any obvious variations in size, shape or other characteristics not relevant to the point of the invention. It should also be noted that although

certain of the exemplary embodiments above lend them selves to discrete battery sizes only, others (for example embodiments with elastomeric elements) may lend themselves to a variety of battery sizes, along a continuum).

What is claimed is:

1. A portable electronic device having a battery compartment and a removable cover therefor, the portable electronic device comprising at least one elastomeric element secured to said cover so as to permit said battery compartment to accommodate batteries of at least two different sizes, wherein said at least one elastomeric element permits said battery compartment to accommodate batteries of at least two different sizes without further adaptation of the battery compartment itself.
2. The portable electronic device of claim 1, wherein said cover has at least one said elastomeric element beneath said cover to bear against an installed battery, said elastomeric element(s) being compressible from a position adapted to accommodate a relatively thin battery, to a position where a somewhat thicker battery can be accommodated.
3. The portable electronic device of claim 1, wherein said cover has a generally rigid outer frame and a generally rigid centre portion, said outer frame and centre portion being connected by said elastomeric element in the form of a web portion whereby said centre portion may be displaced outwardly to accommodate a somewhat thicker battery.
4. The portable electronic device of claim 3, wherein said elastomeric web portion is a flexible membrane, configured to tuck into a gap between an installed battery and a side wall of the battery compartment.
5. The portable electronic device of claim 1, wherein said cover has a generally rigid outer frame and said elastomeric element in the form of a centre portion secured to said outer frame, whereby said centre portion may be displaced outwardly to accommodate a somewhat thicker battery.

6. The portable electronic device of any one of claims 1 to 5, wherein said at least two sizes are discrete sizes.

7. The portable electronic device of any one of claims 1 to 5, wherein said at least two sizes are various sizes along a continuum of sizes.

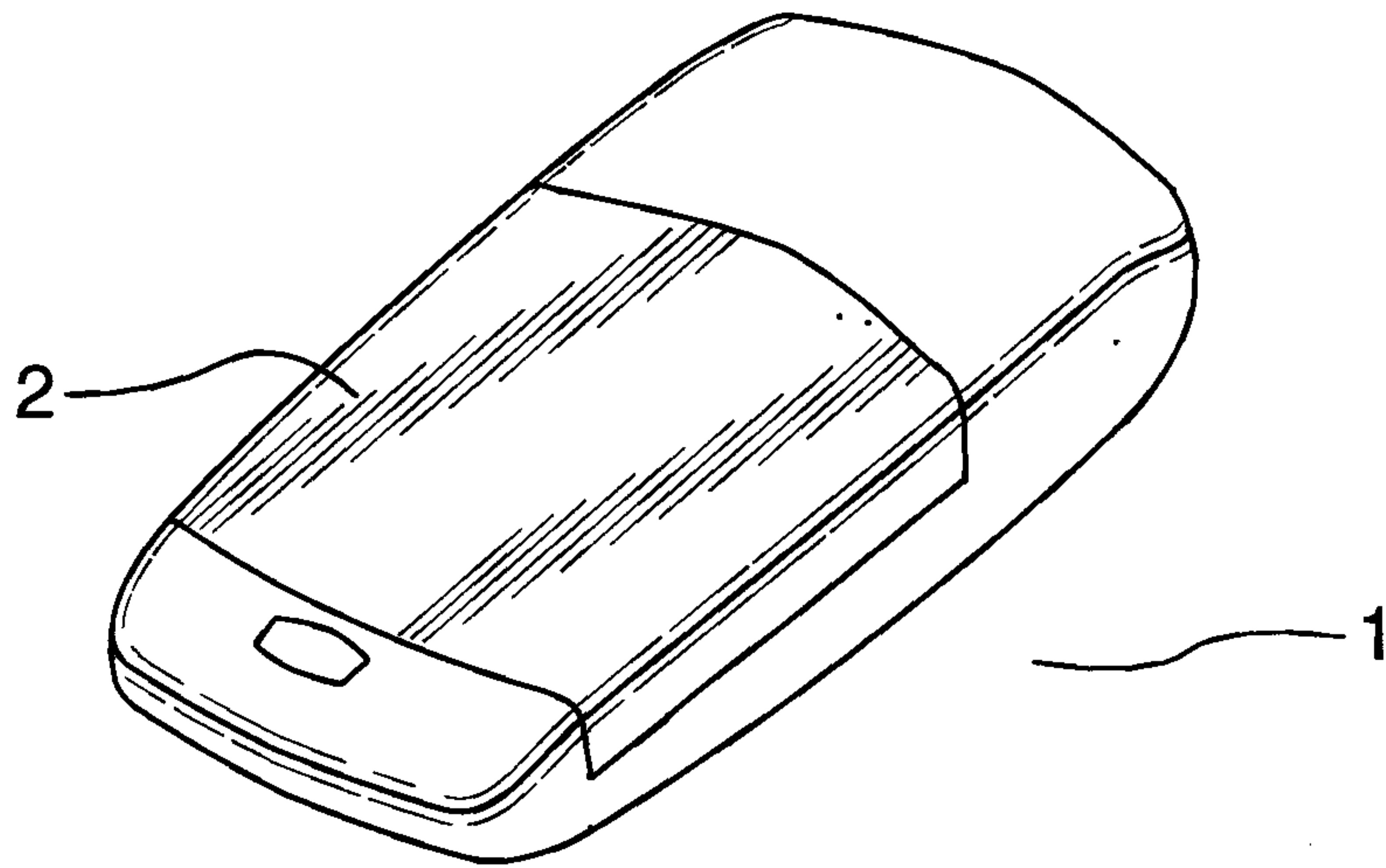

FIG. 1

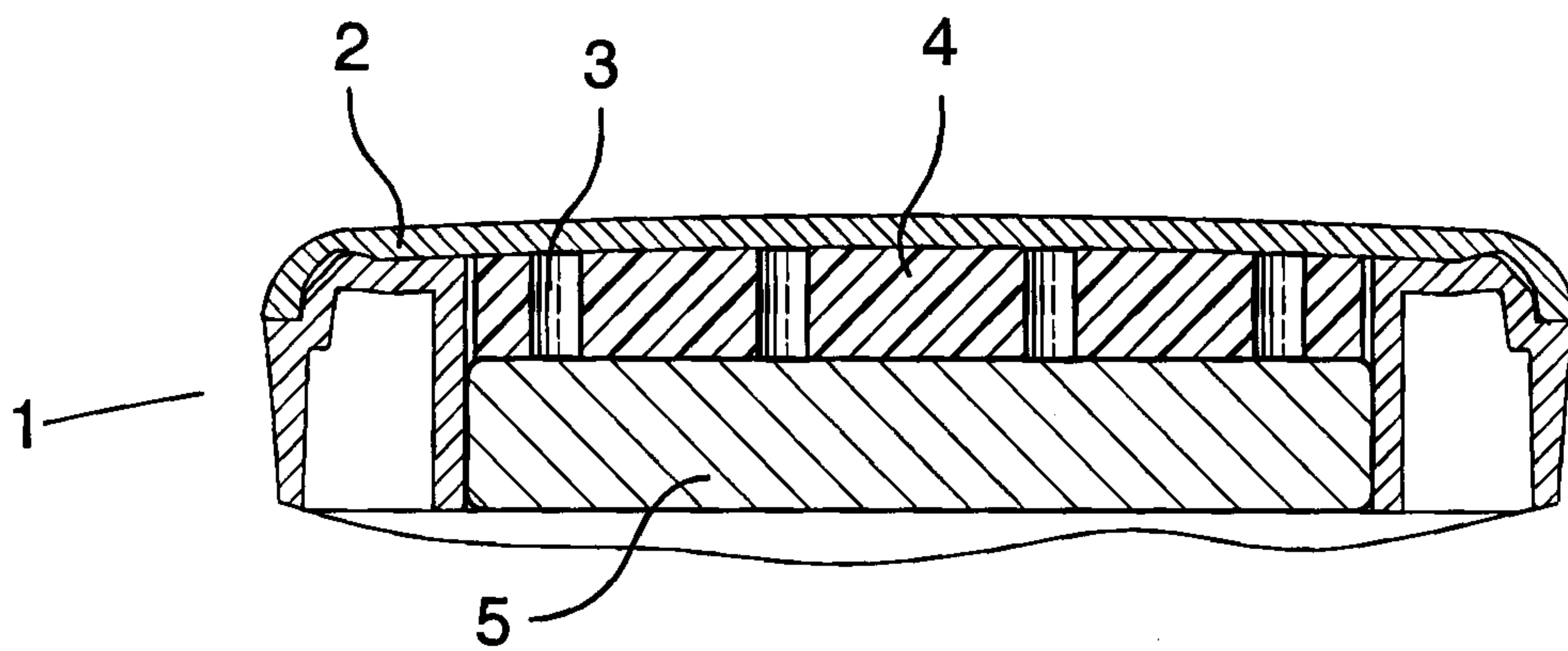

FIG. 2

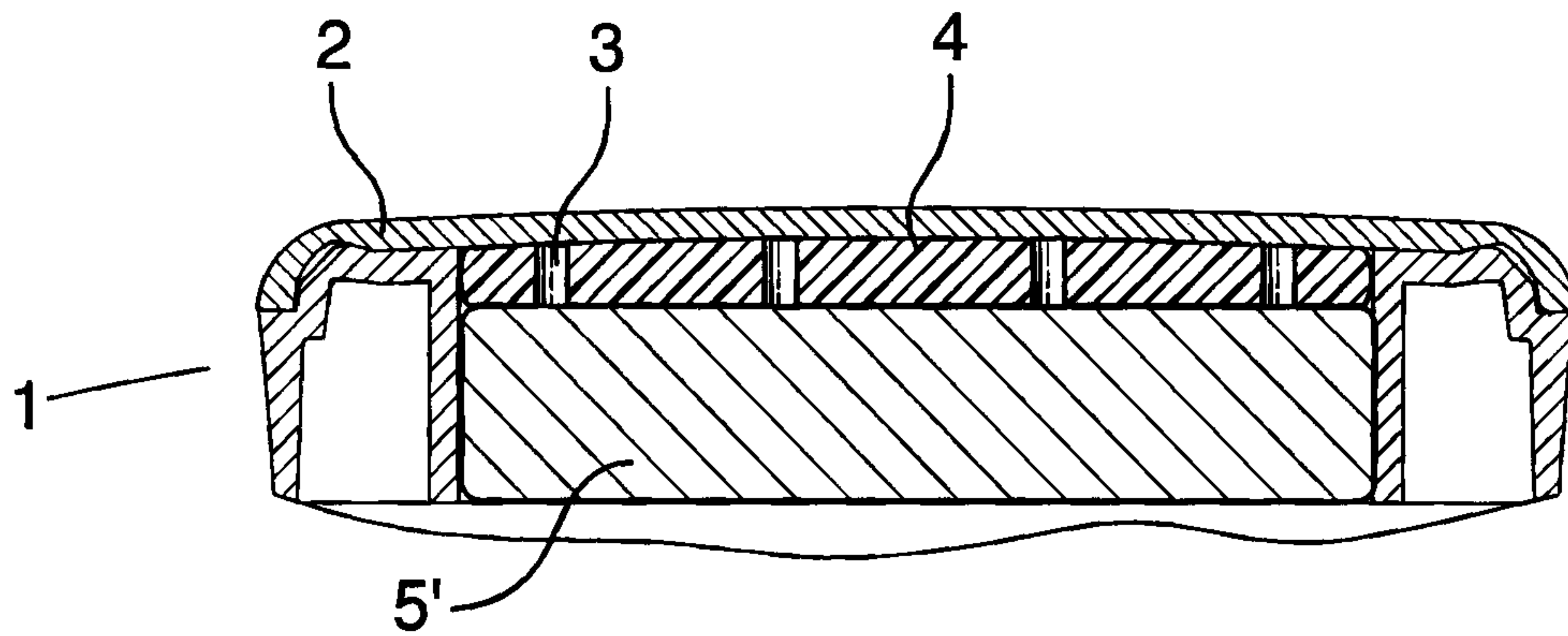

FIG. 3

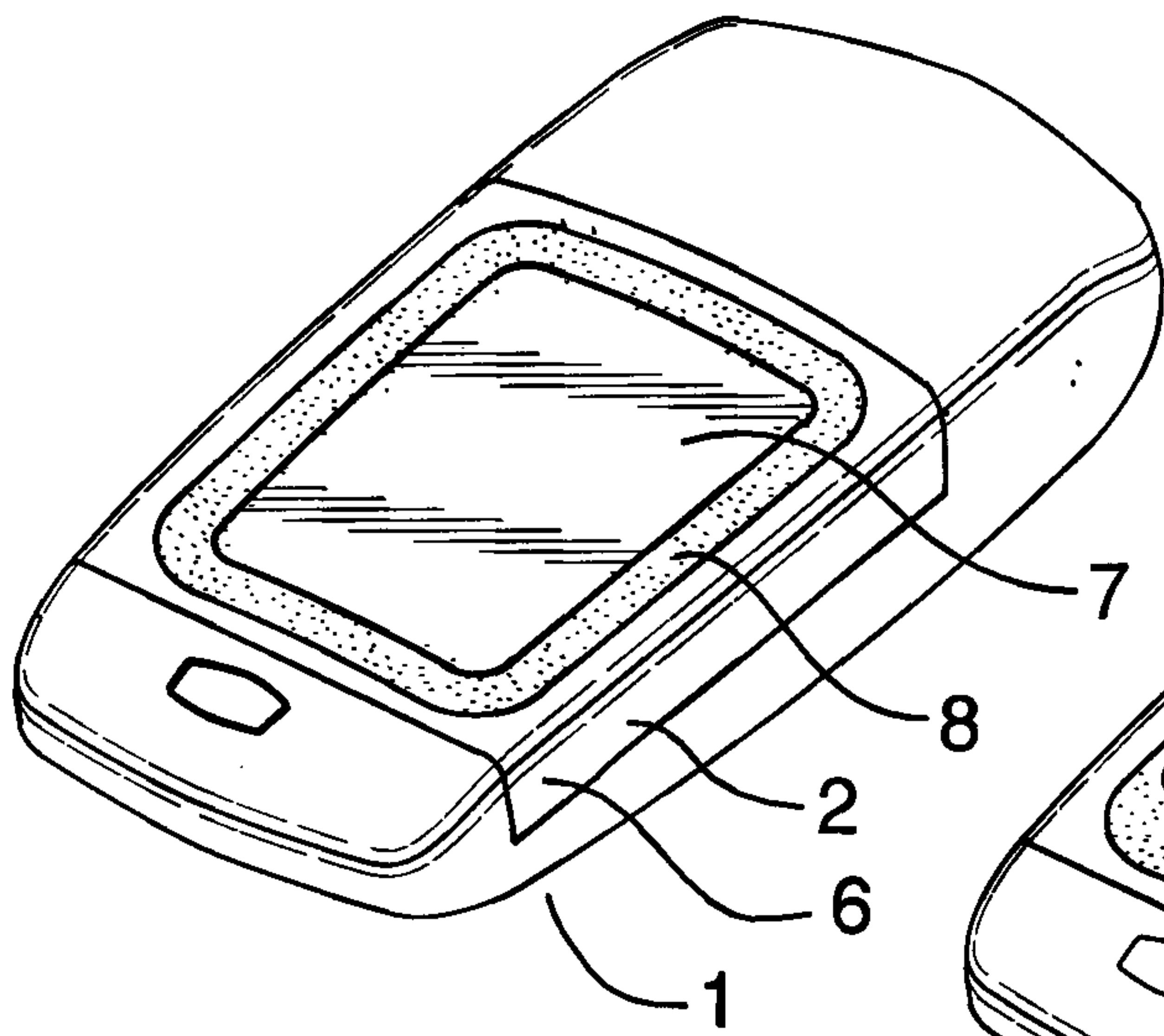

FIG. 4

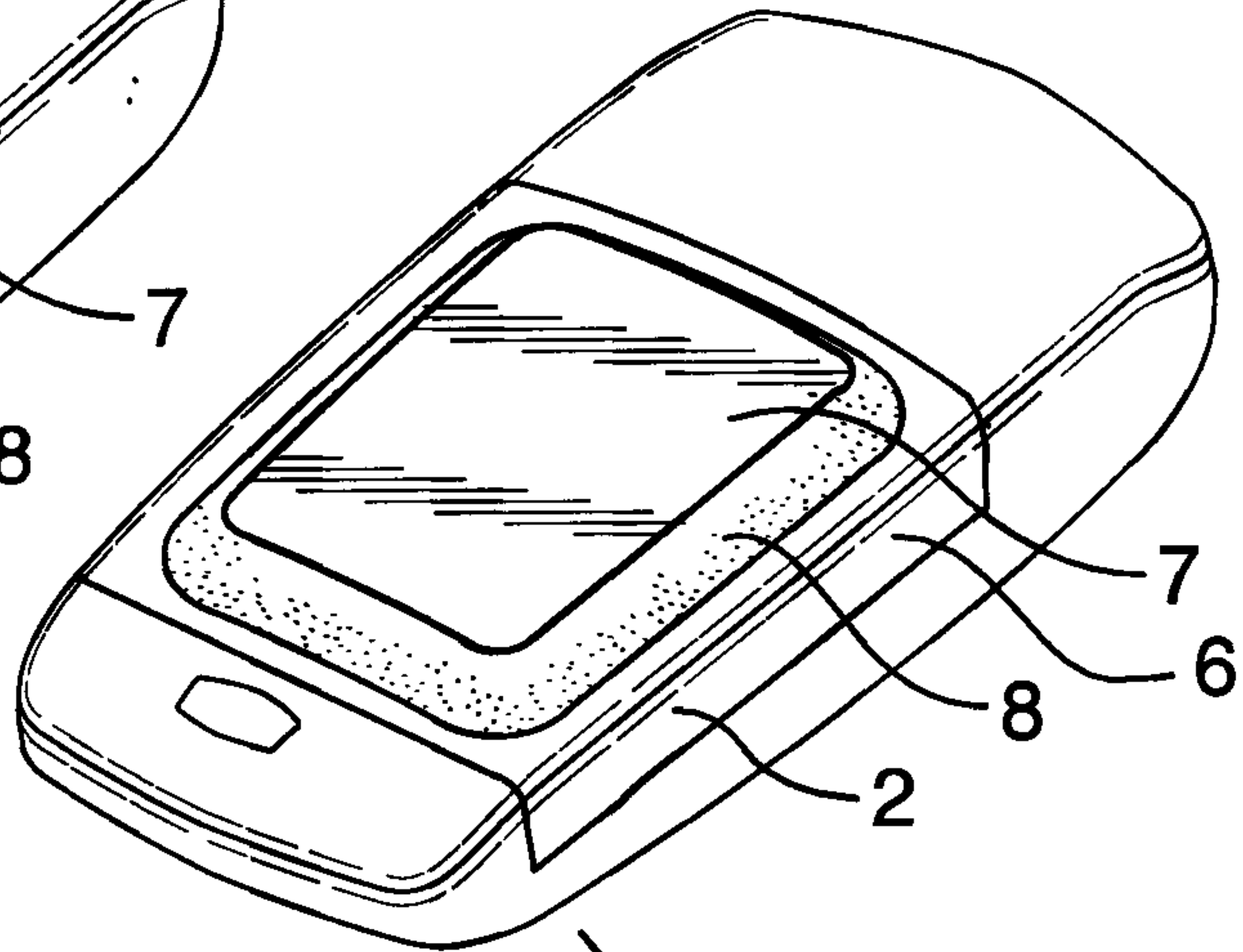

FIG. 5

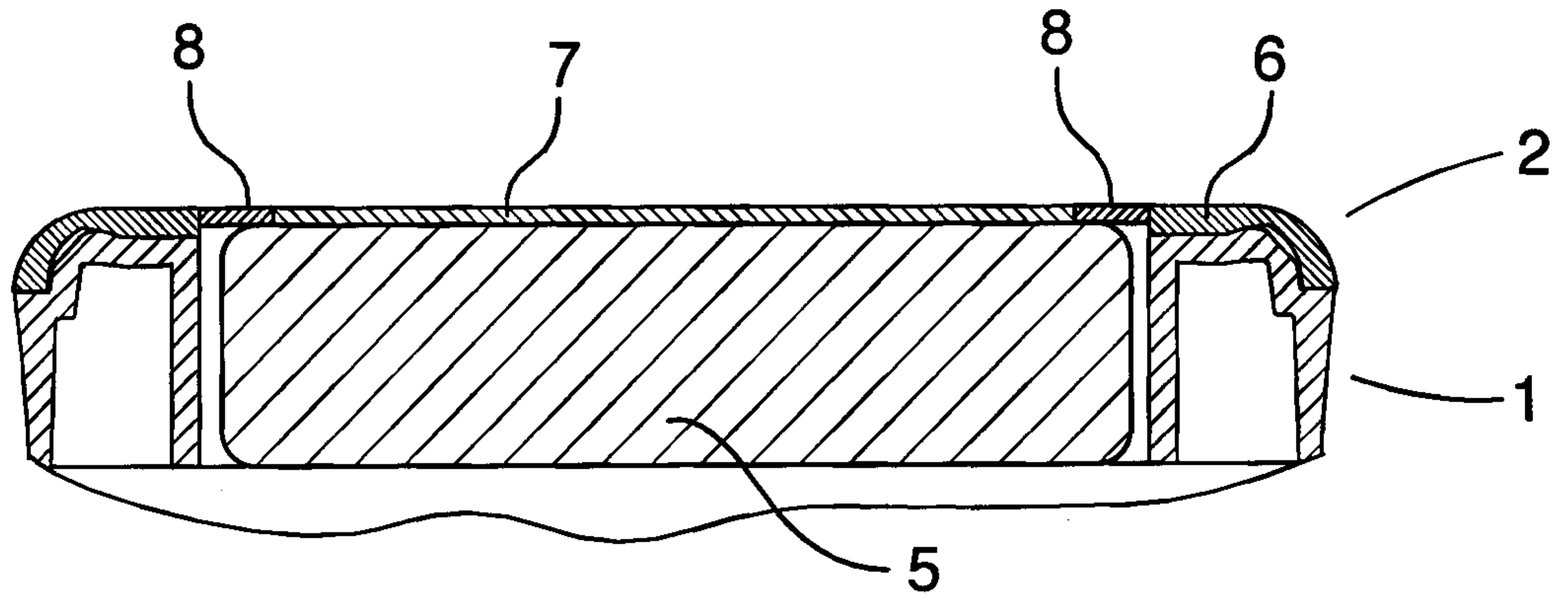

FIG. 6

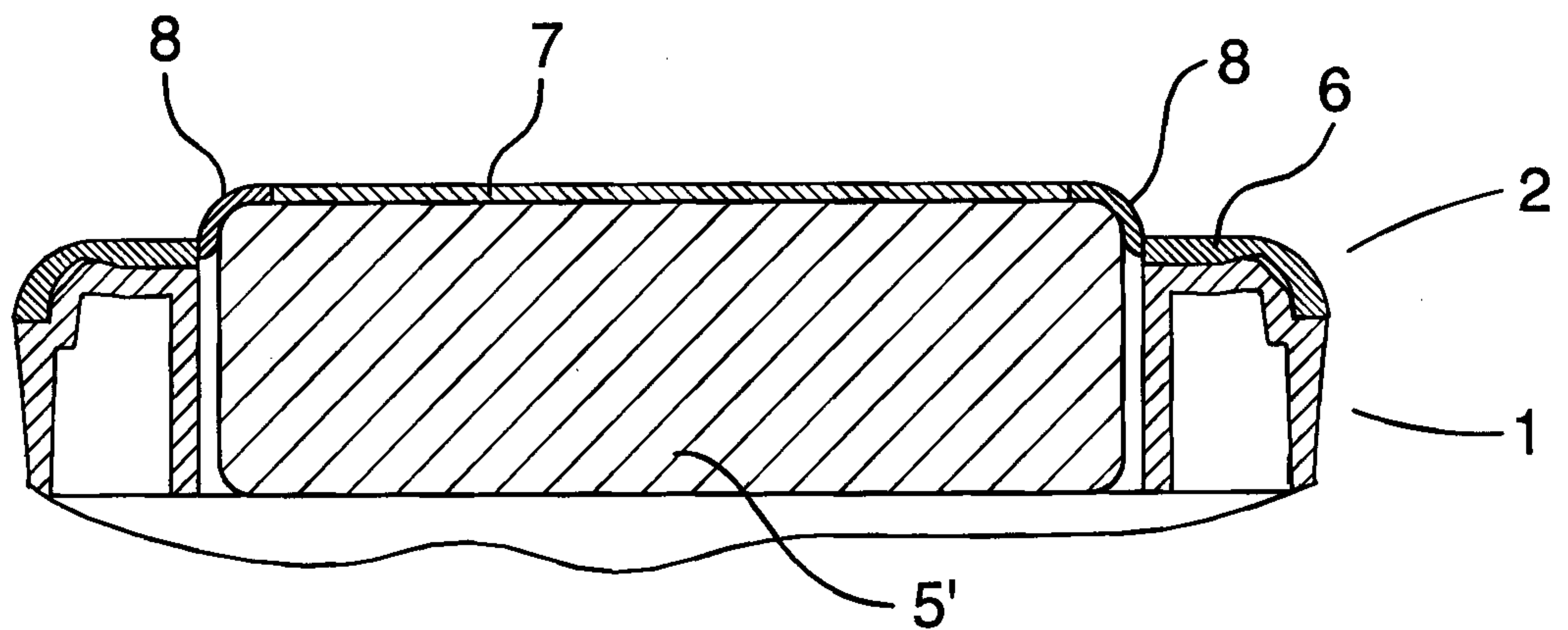

FIG. 7

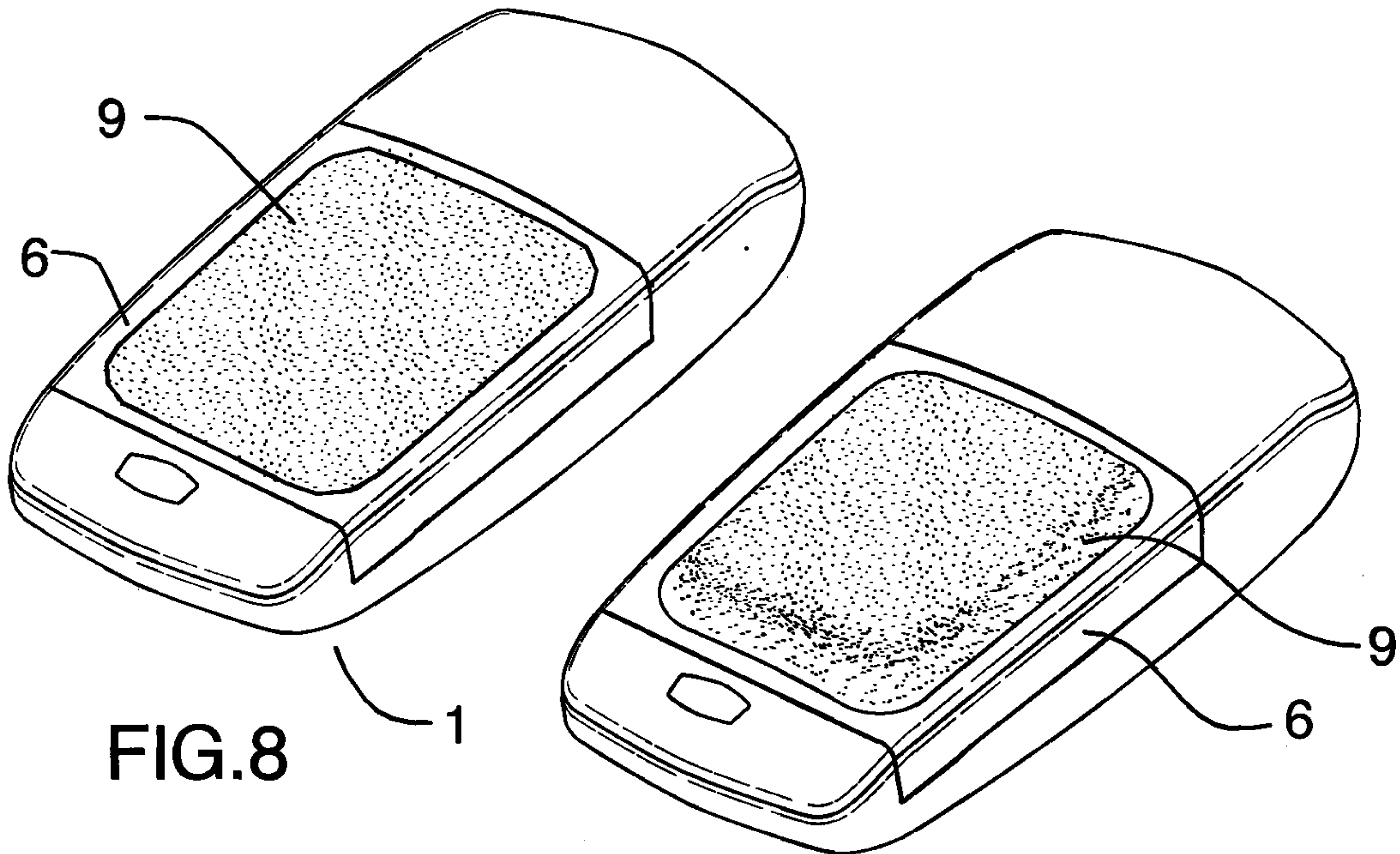

FIG. 8

FIG. 9

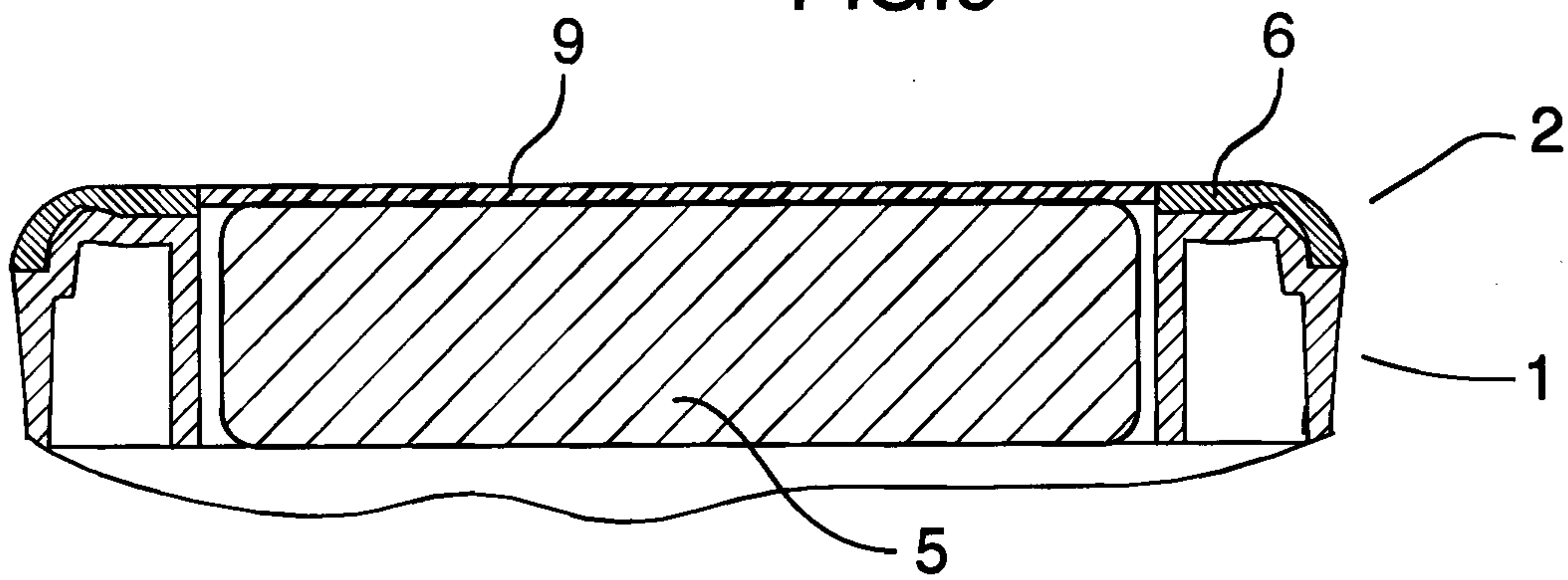

FIG. 10

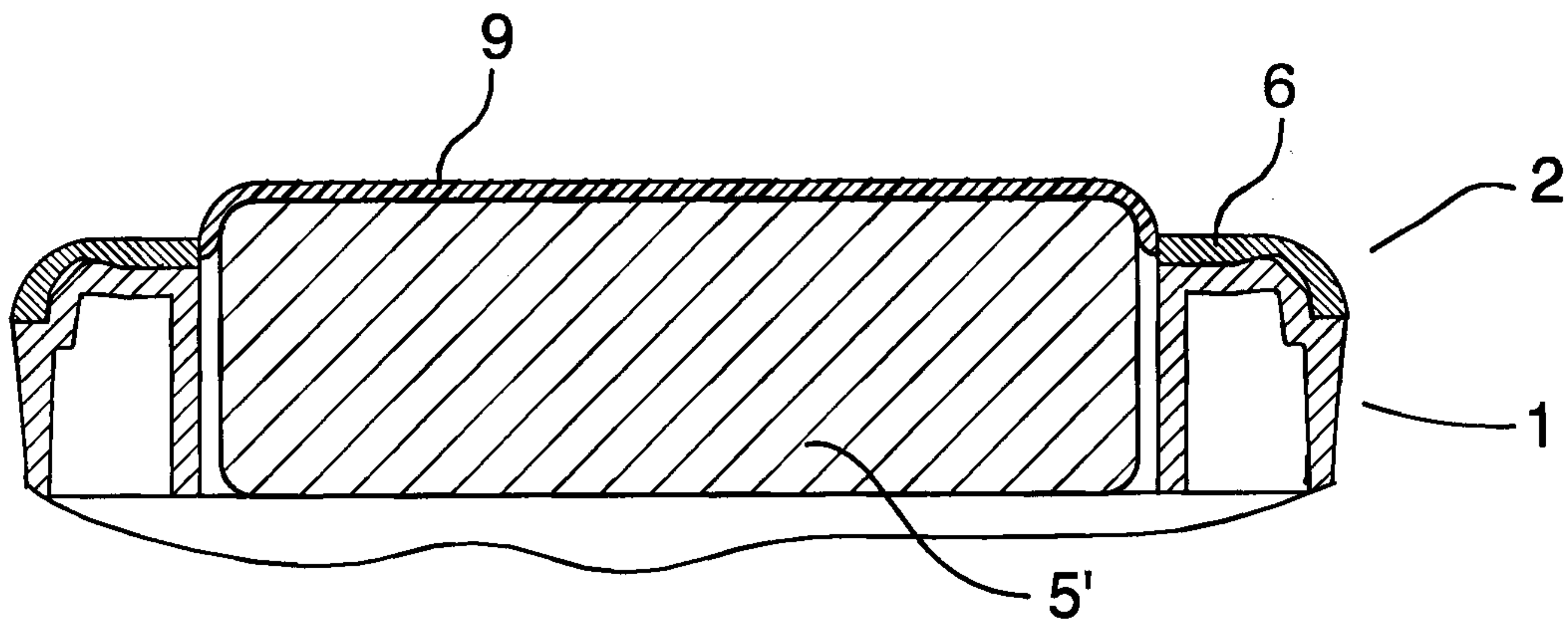

FIG. 11

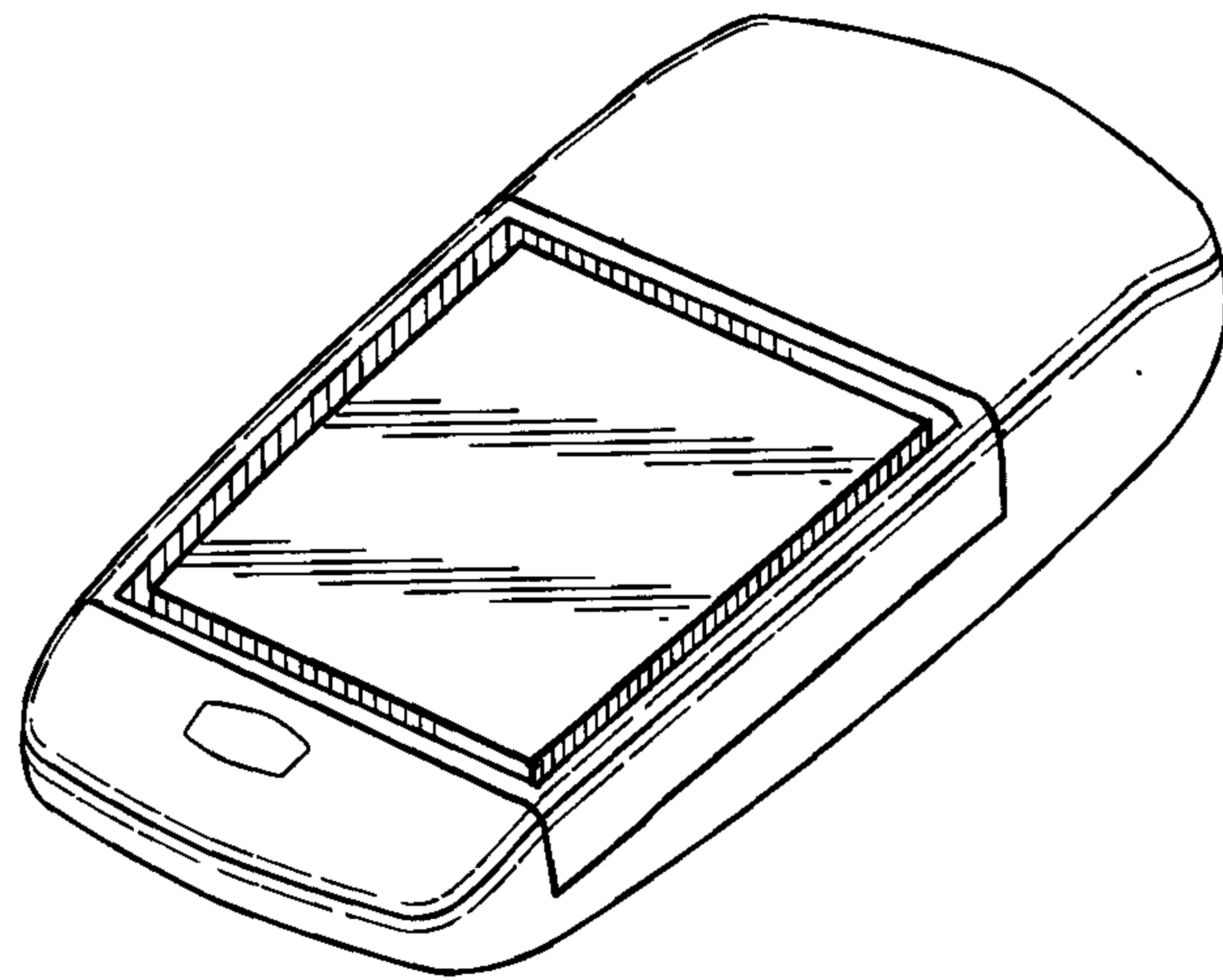

FIG. 12

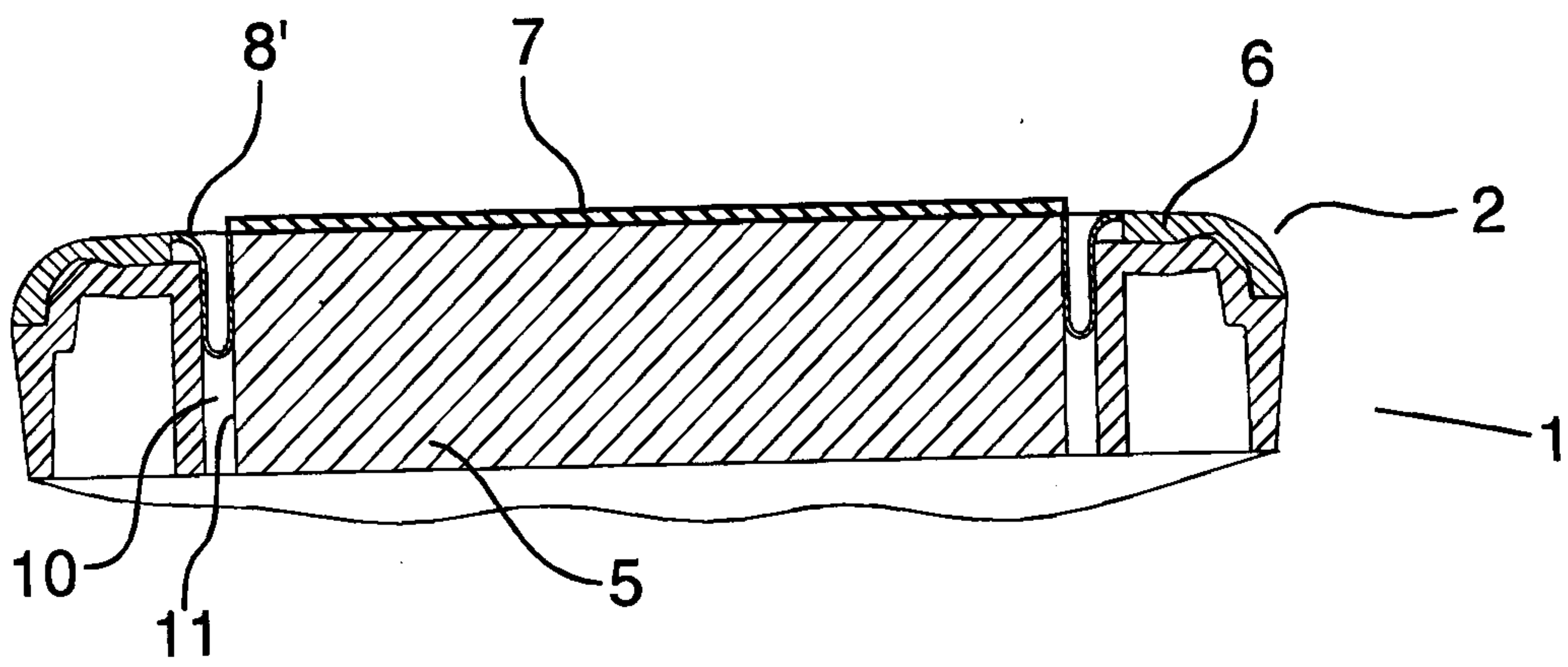

FIG. 13

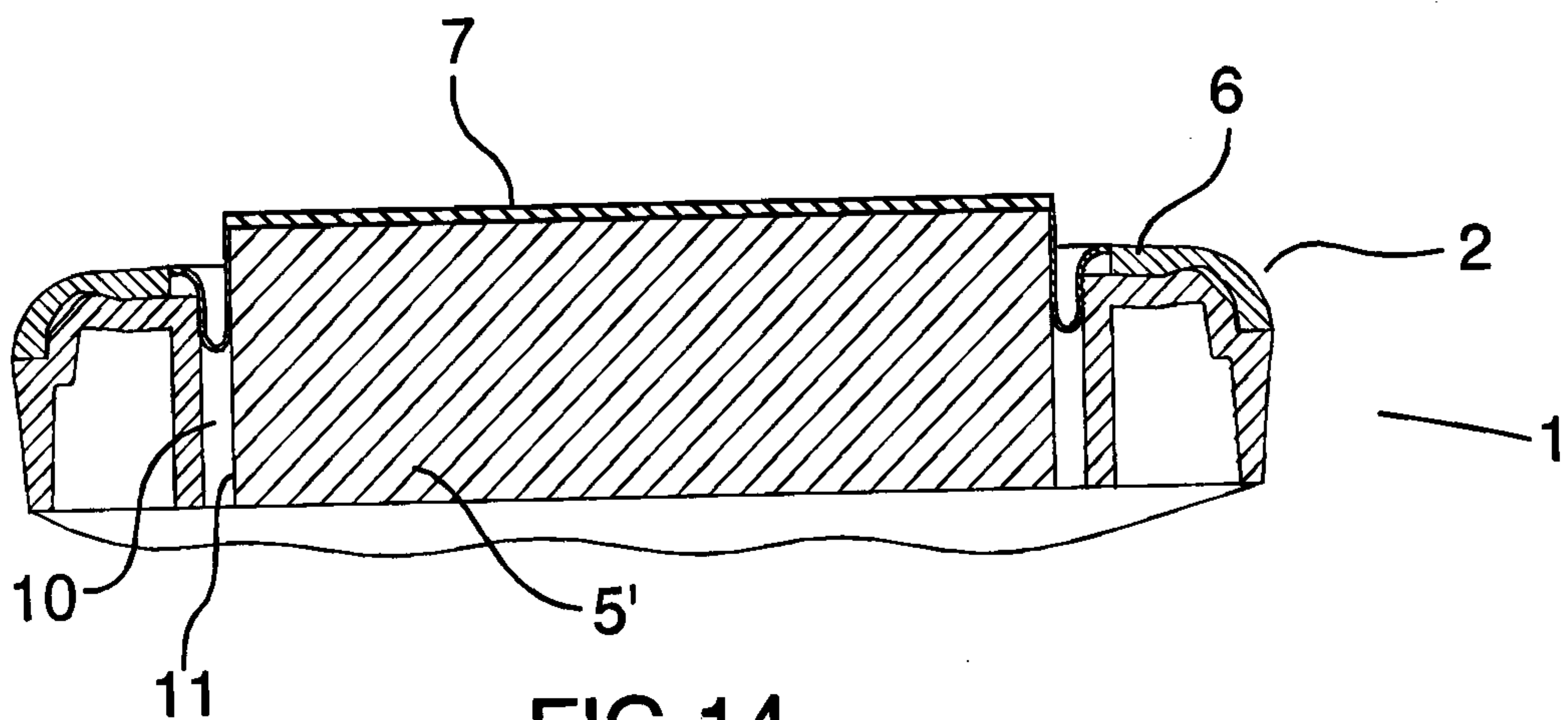

FIG. 14

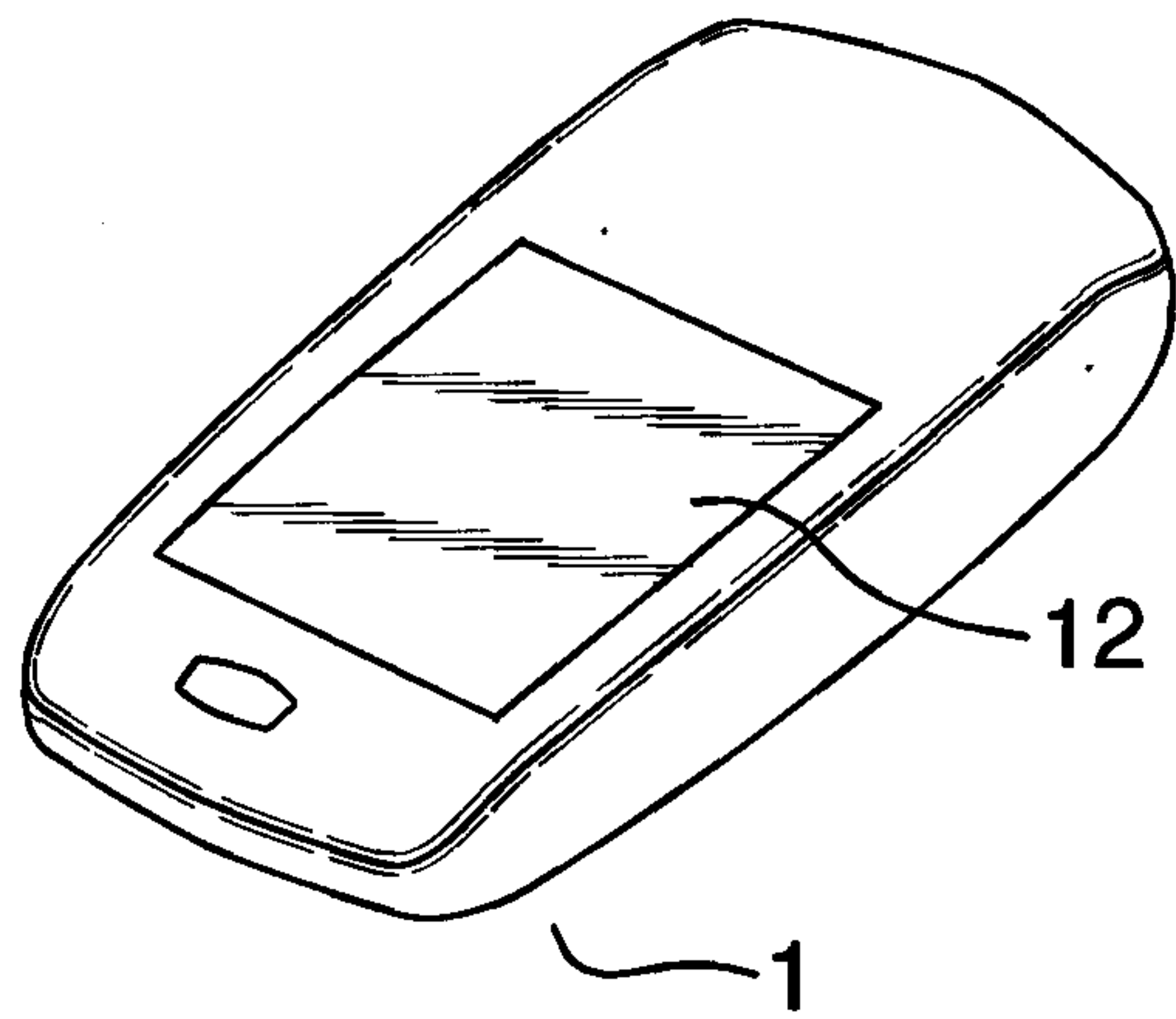

FIG. 15

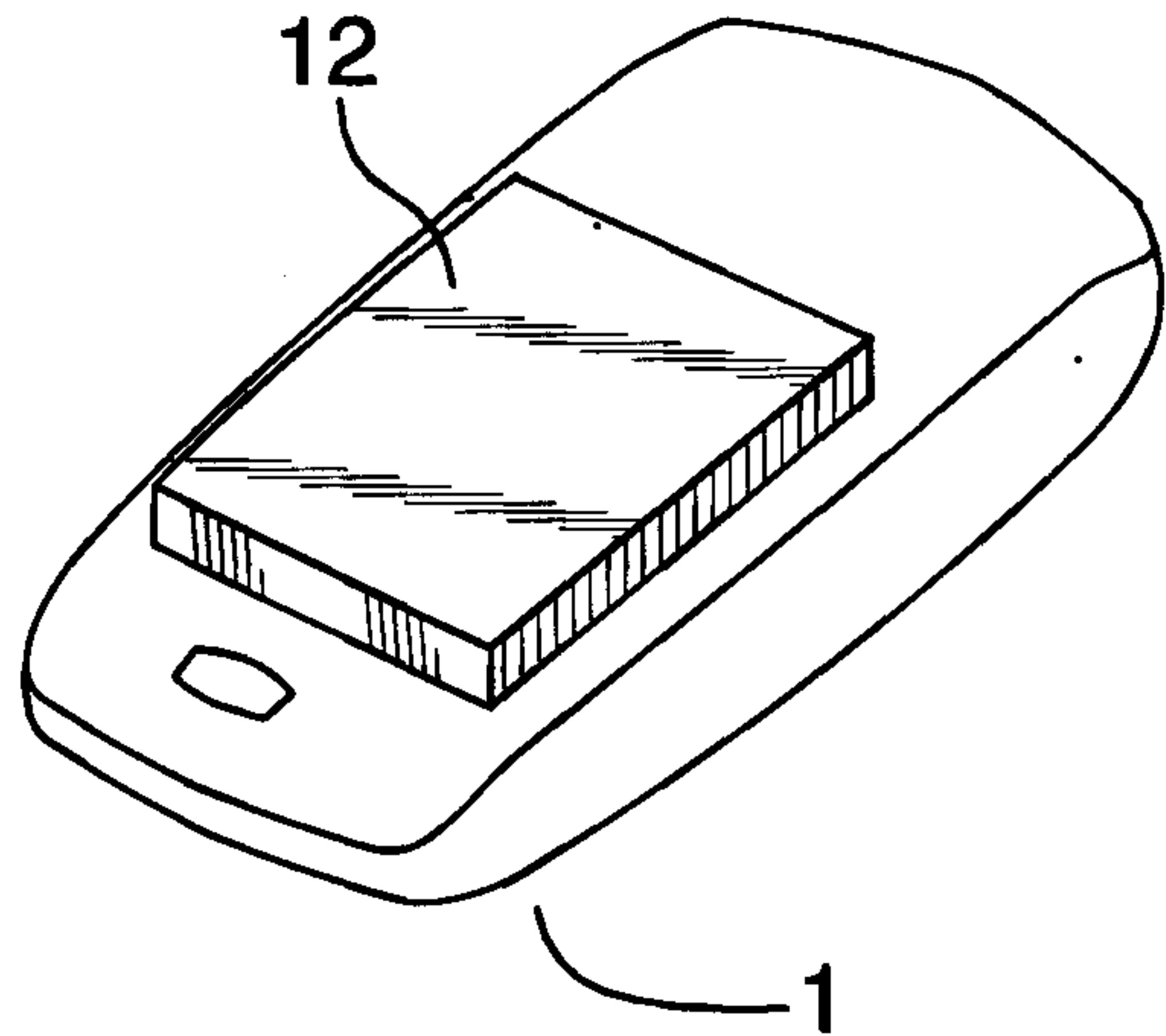

FIG. 16

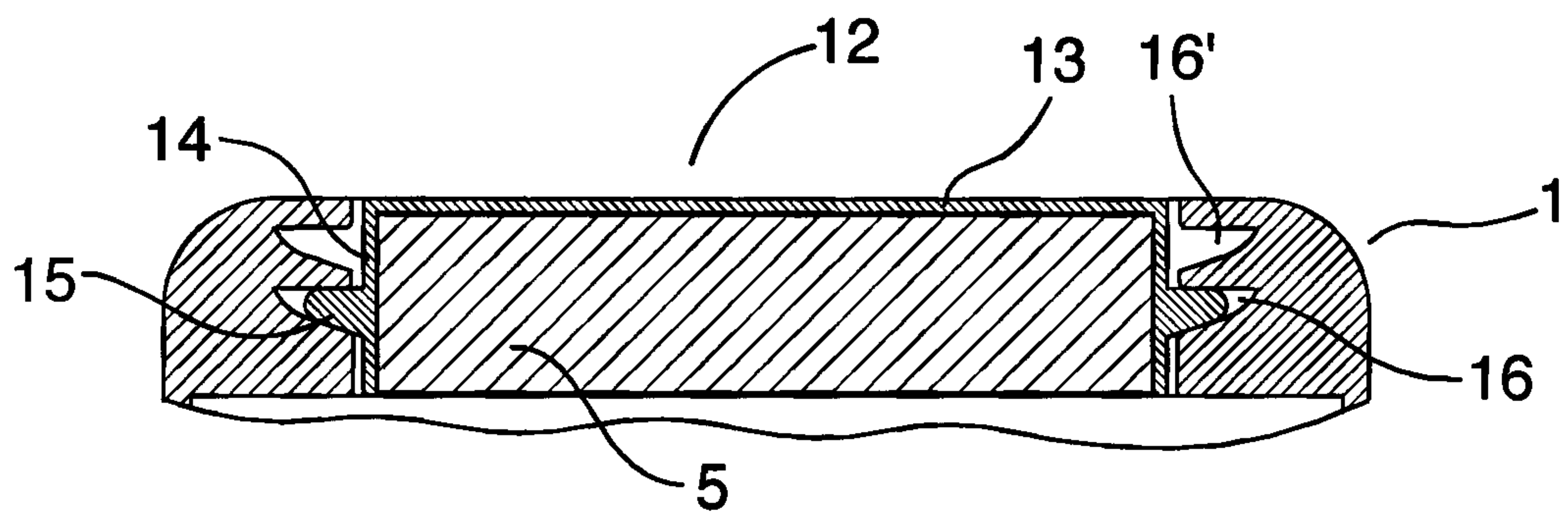

FIG. 17

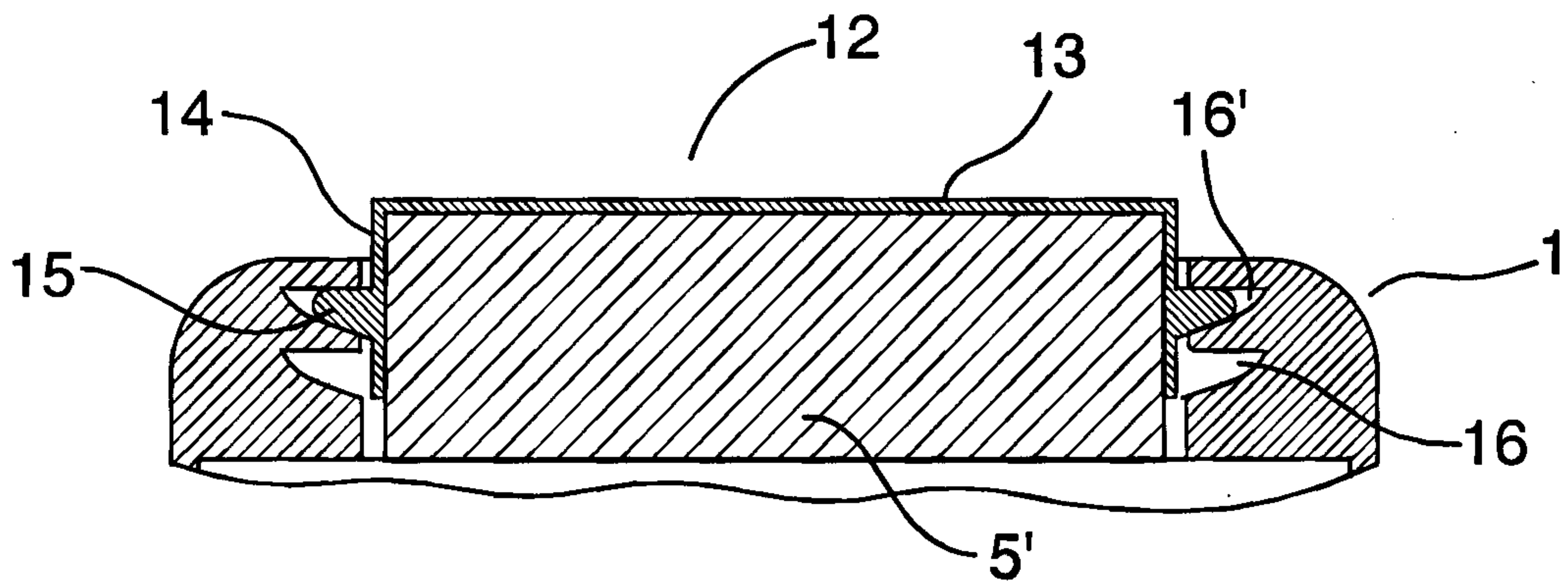

FIG. 18

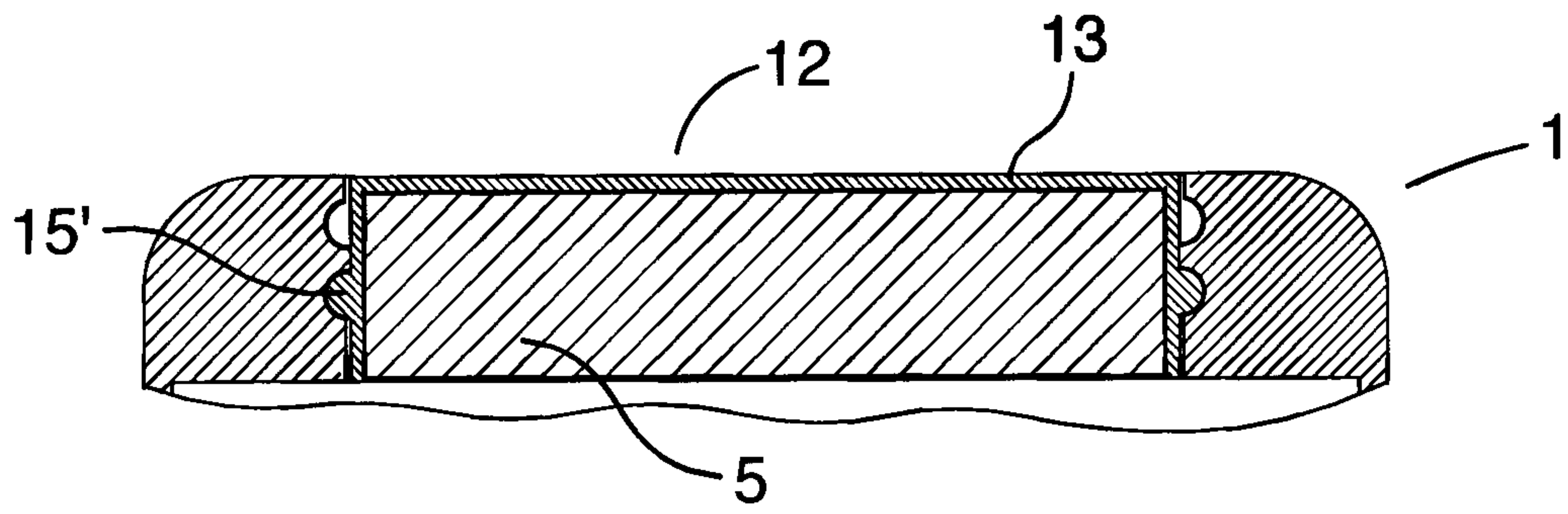

FIG.19

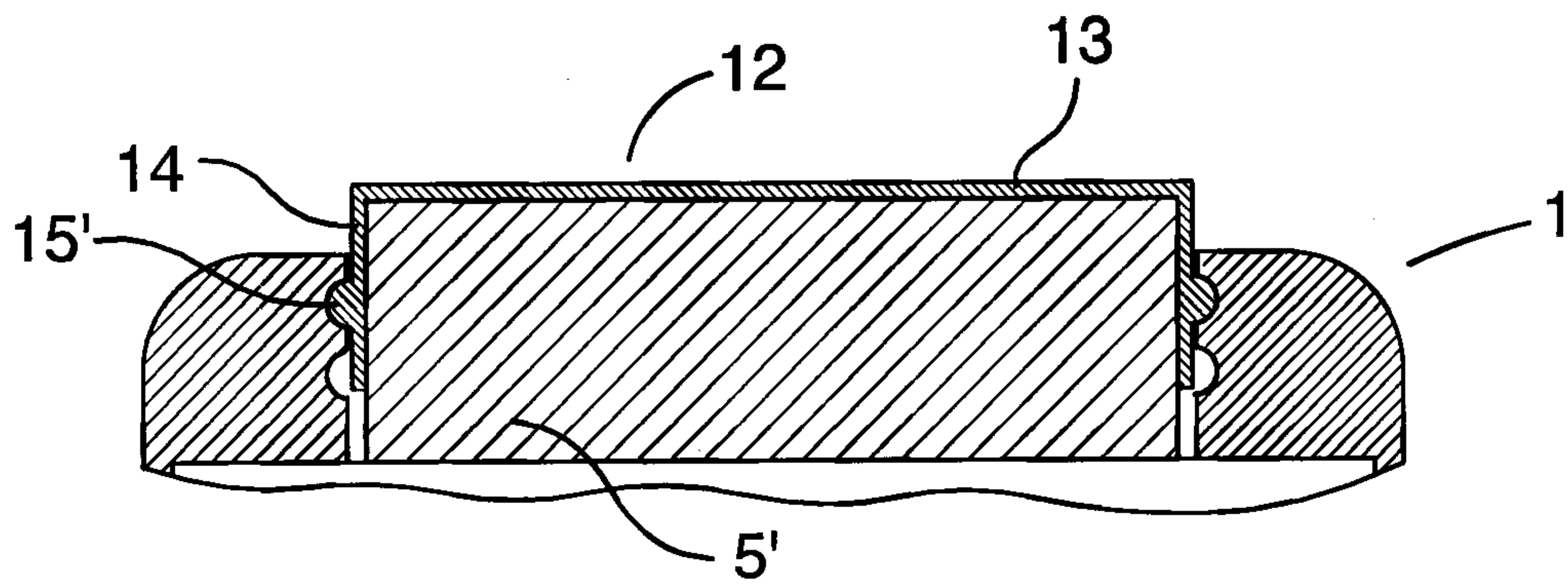

FIG.20

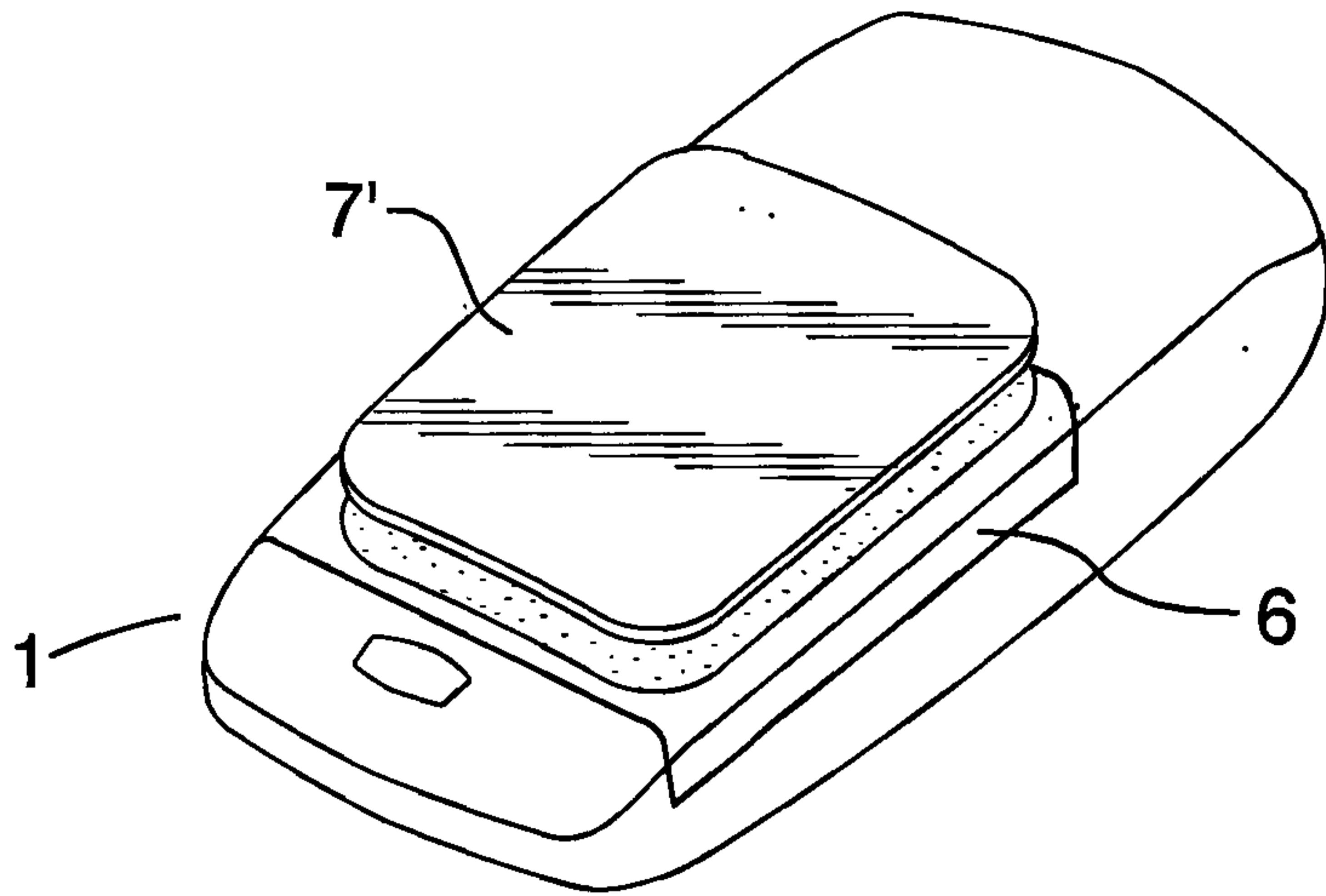

FIG. 21

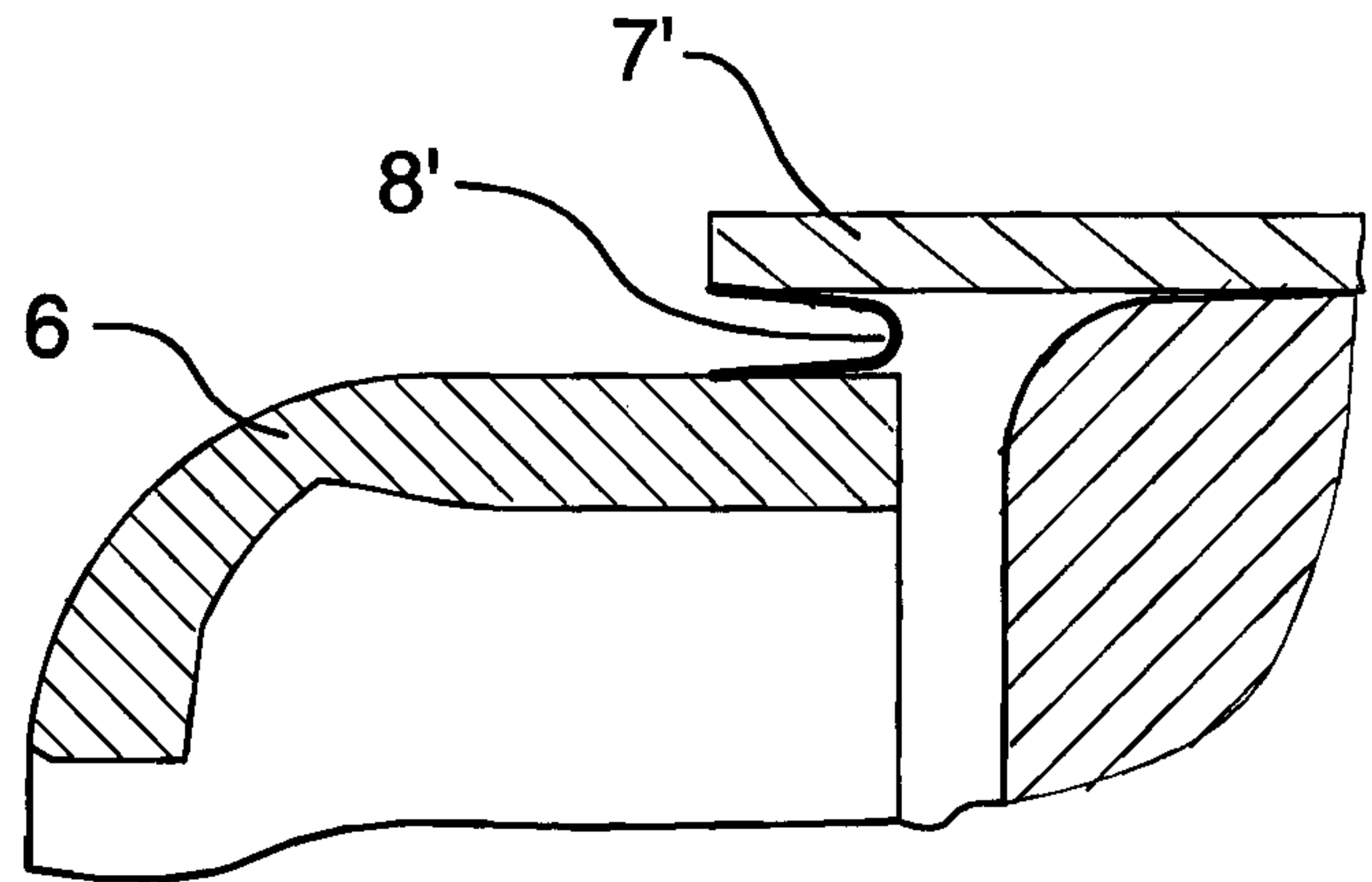

FIG. 22

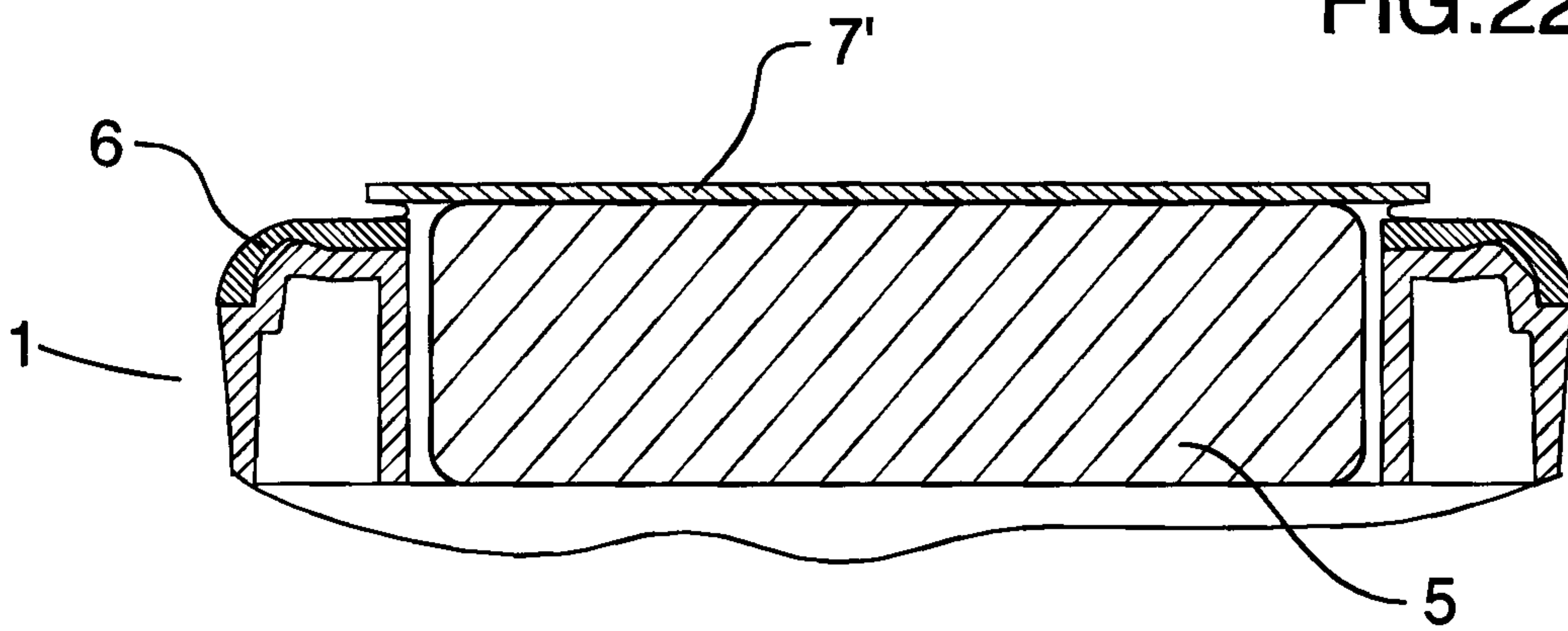

FIG. 23

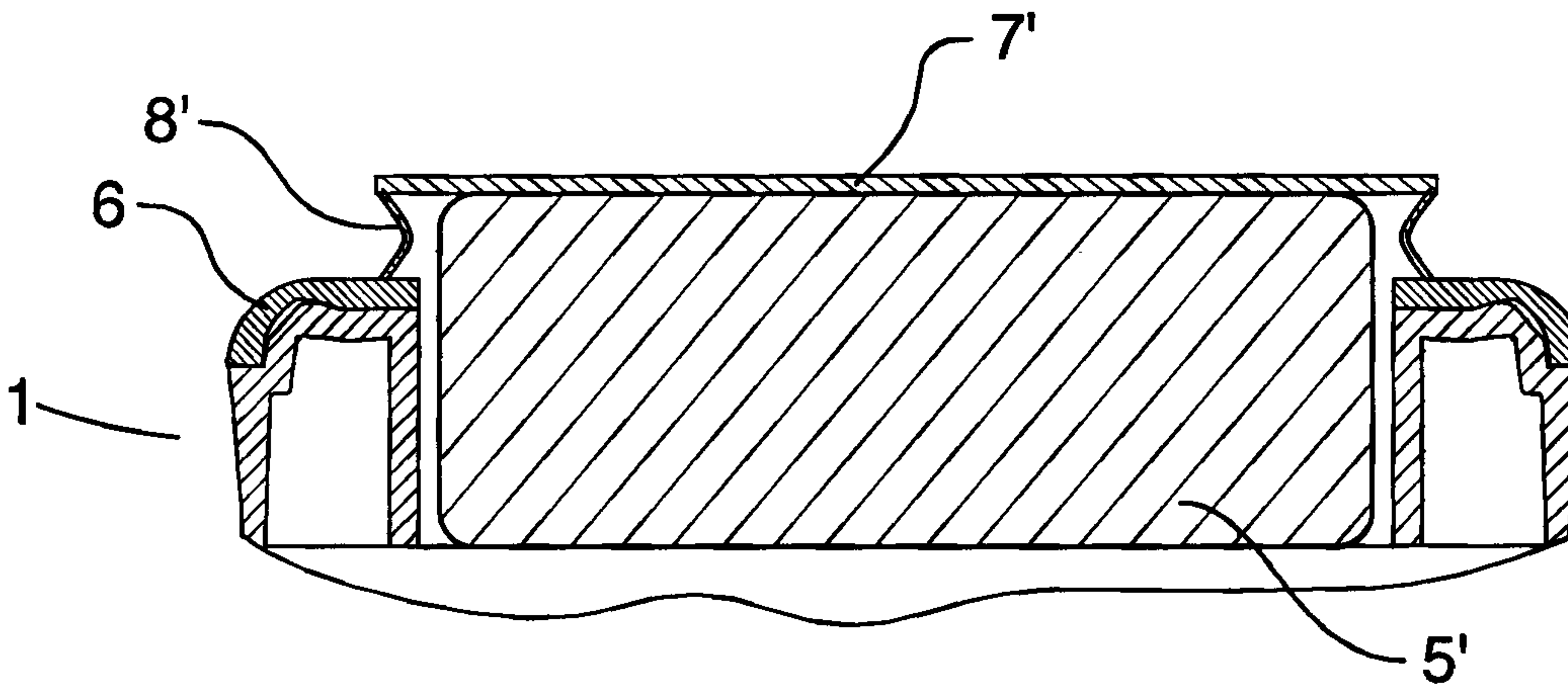

FIG. 24

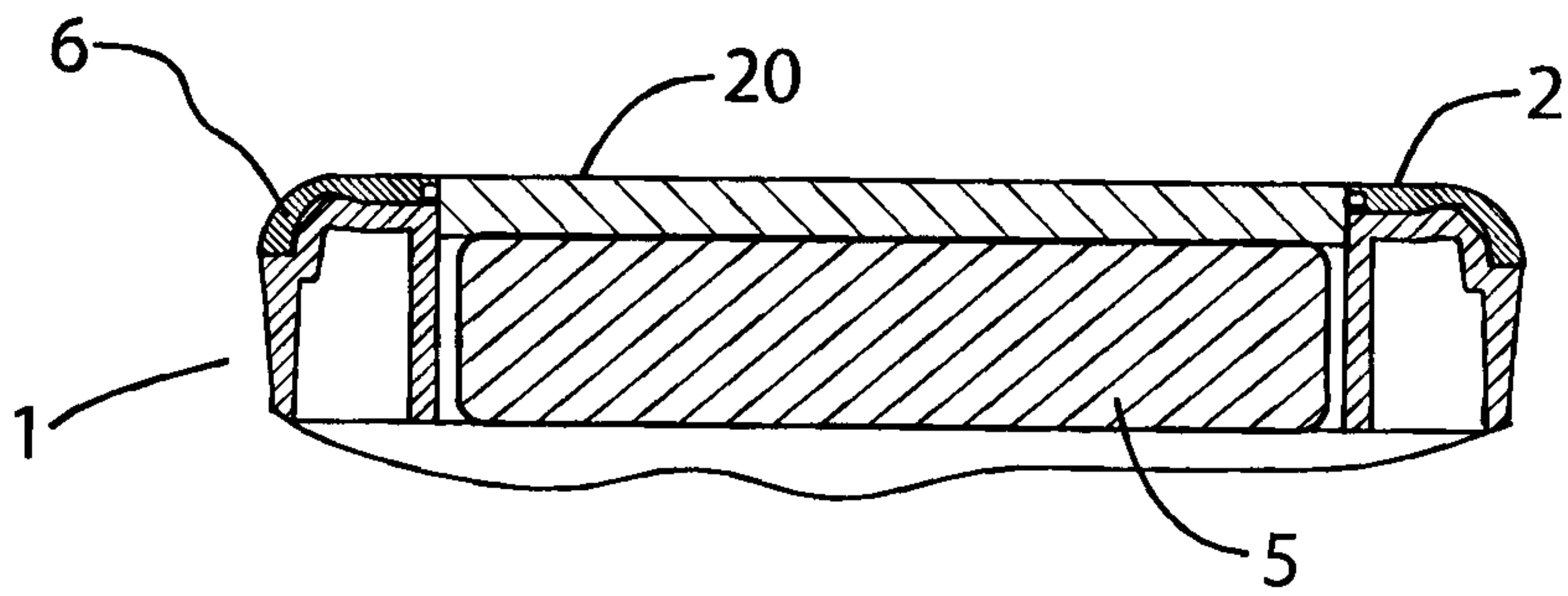

FIG. 25

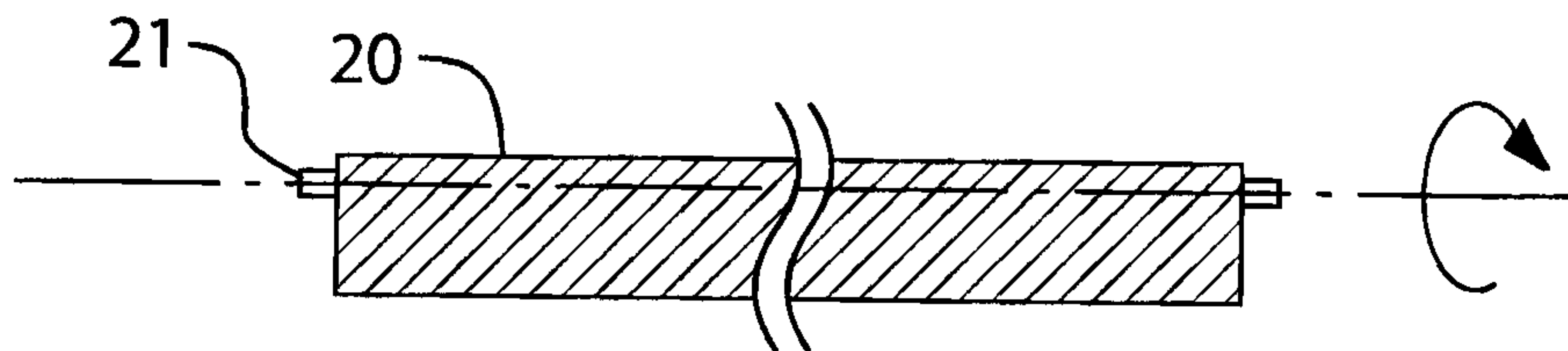

FIG. 26

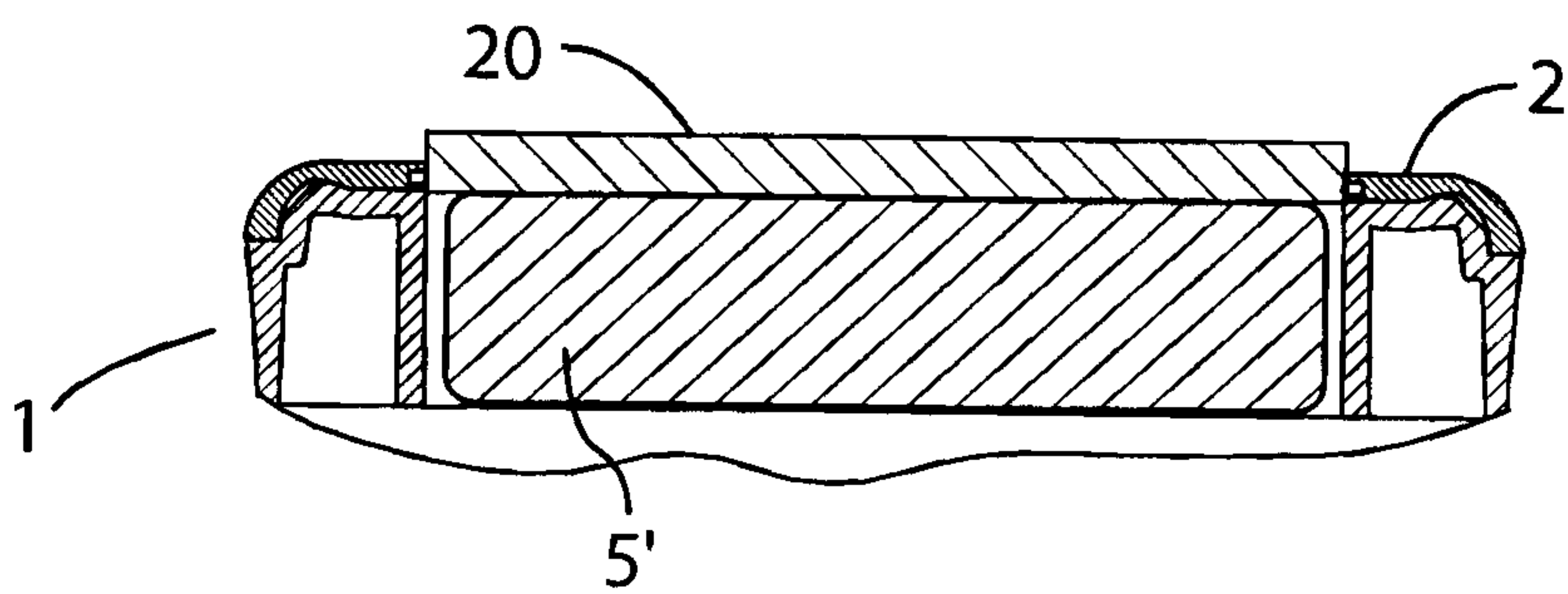

FIG. 27

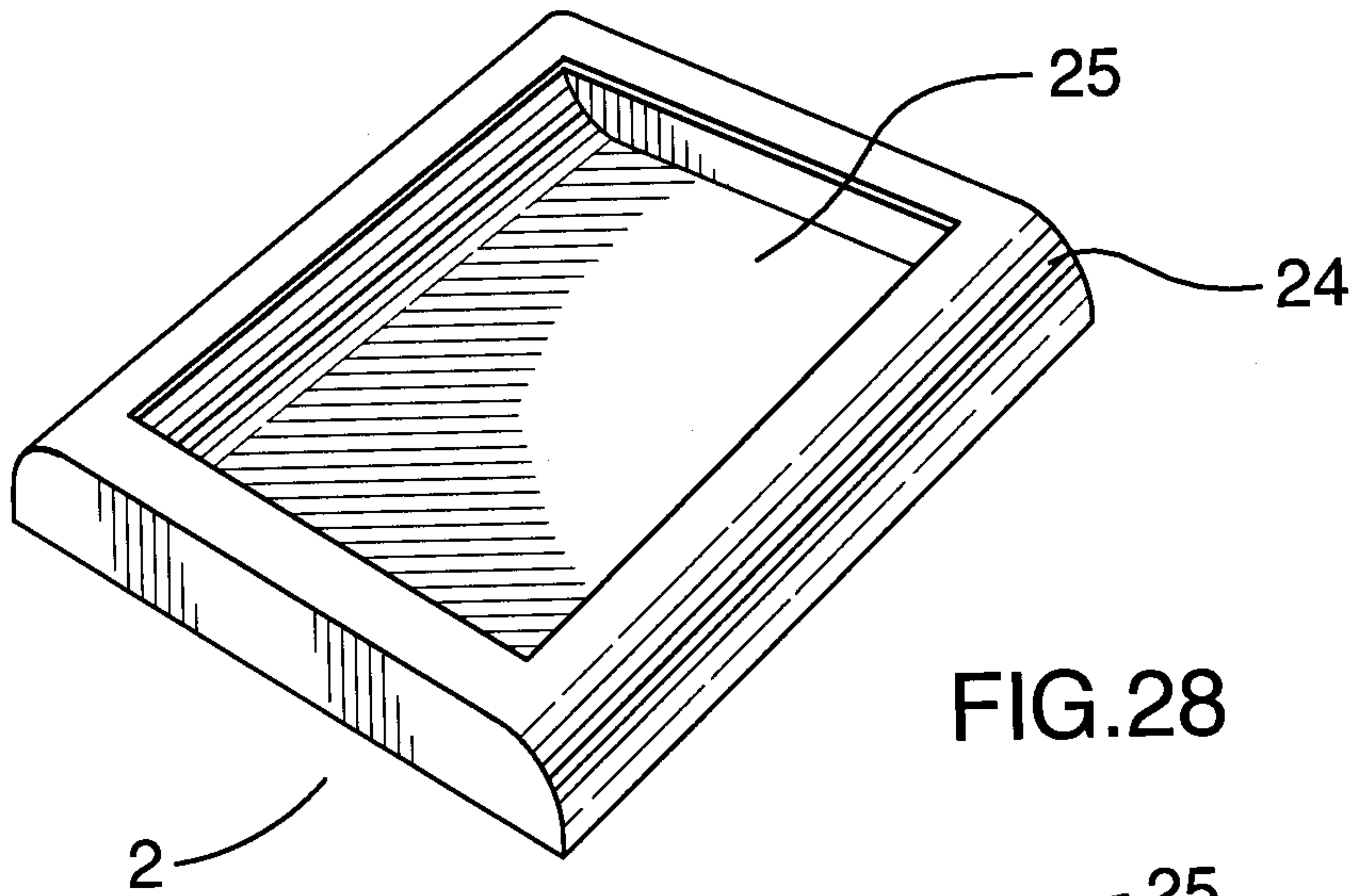

FIG. 28

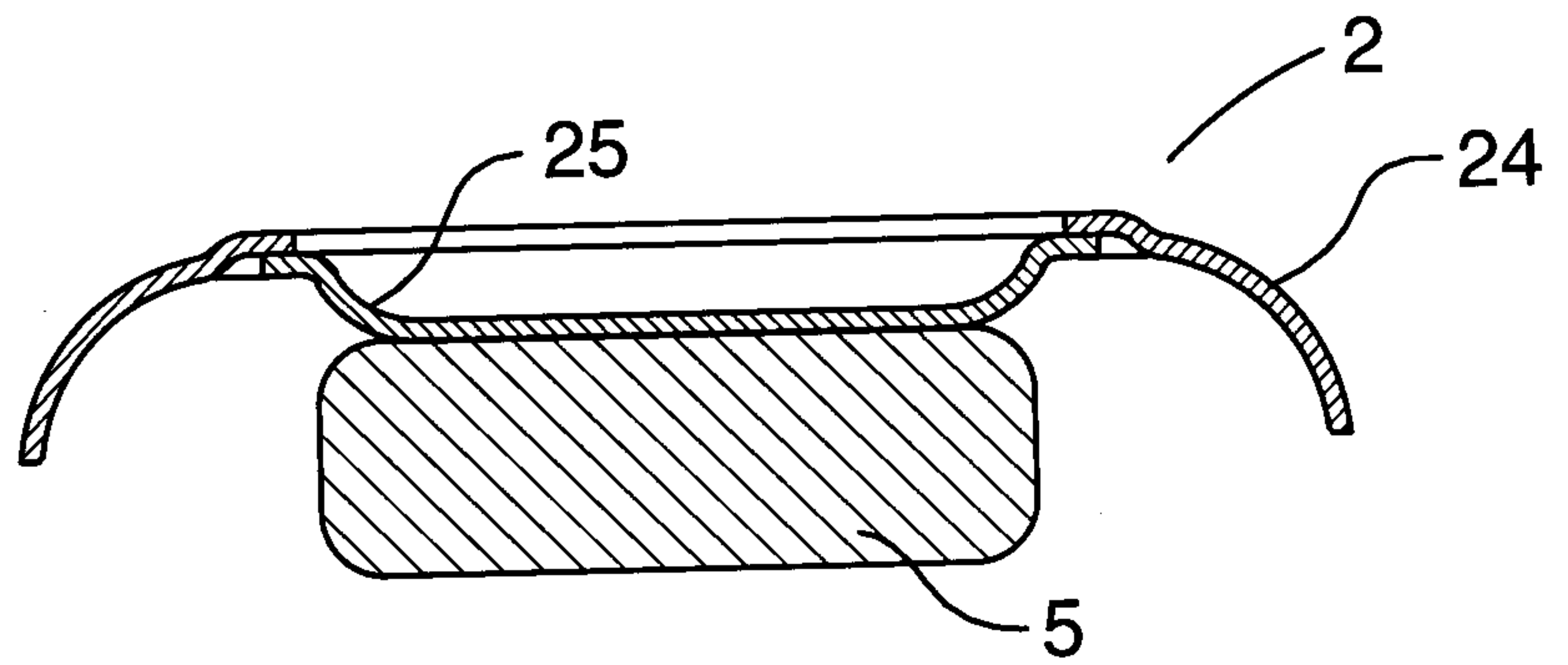

FIG. 29

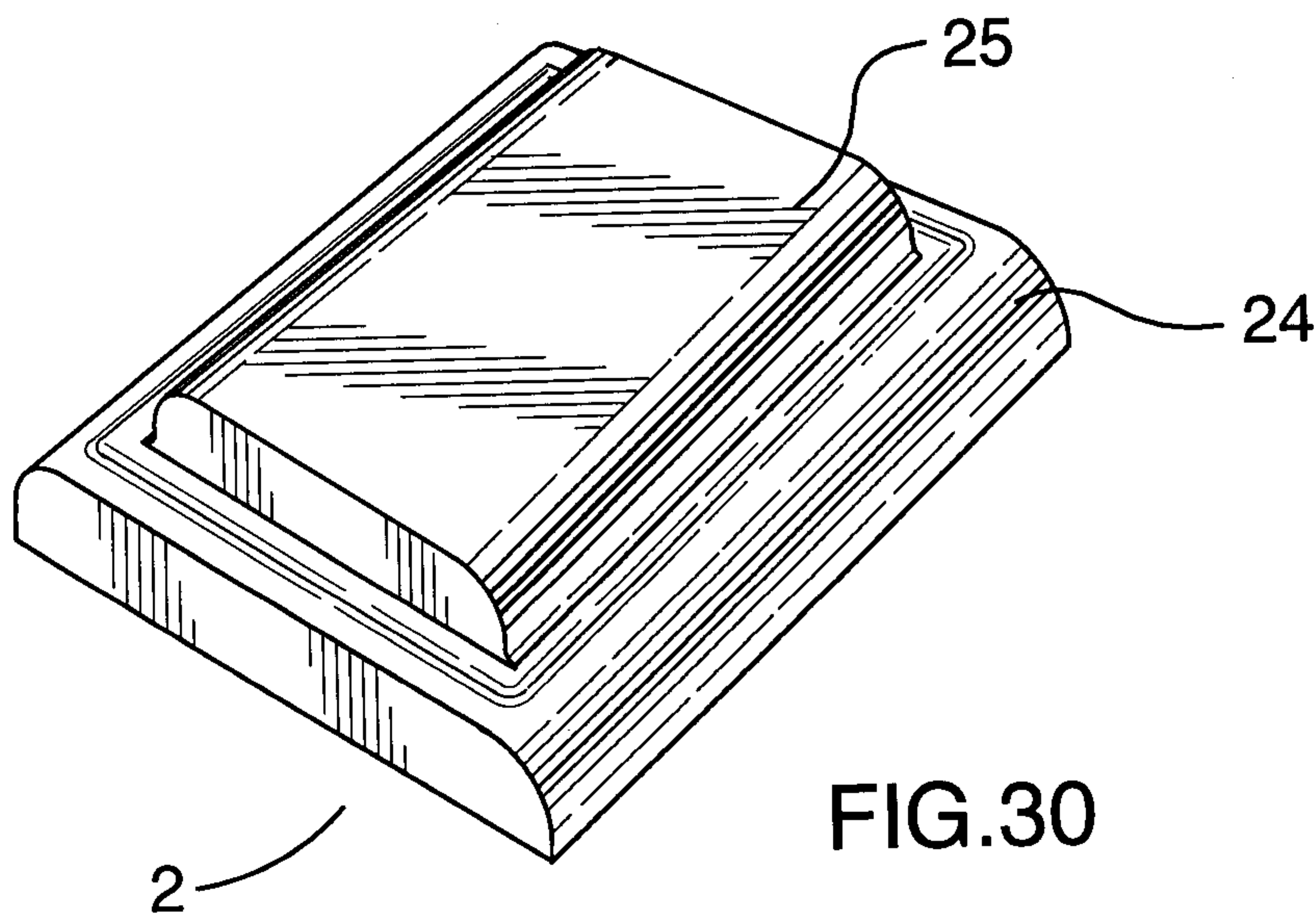

FIG. 30

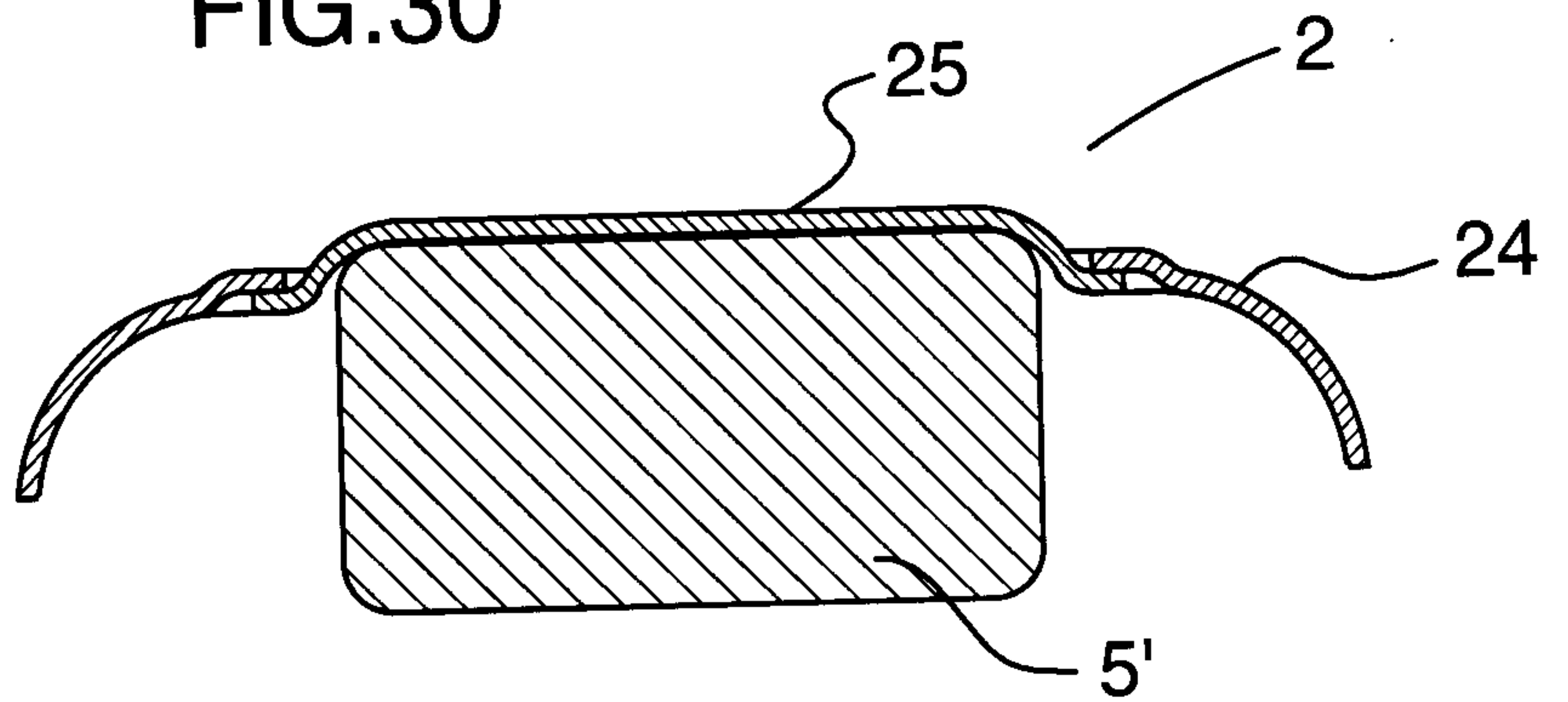

FIG. 31

