

(No Model.)

3 Sheets—Sheet 1.

# C. I. WALKER & F. J. JERVEY.

## PRESS FOR PLASTIC MATERIAL FOR BUILDING BLOCKS.

No. 323,757.

Patented Aug. 4, 1885.

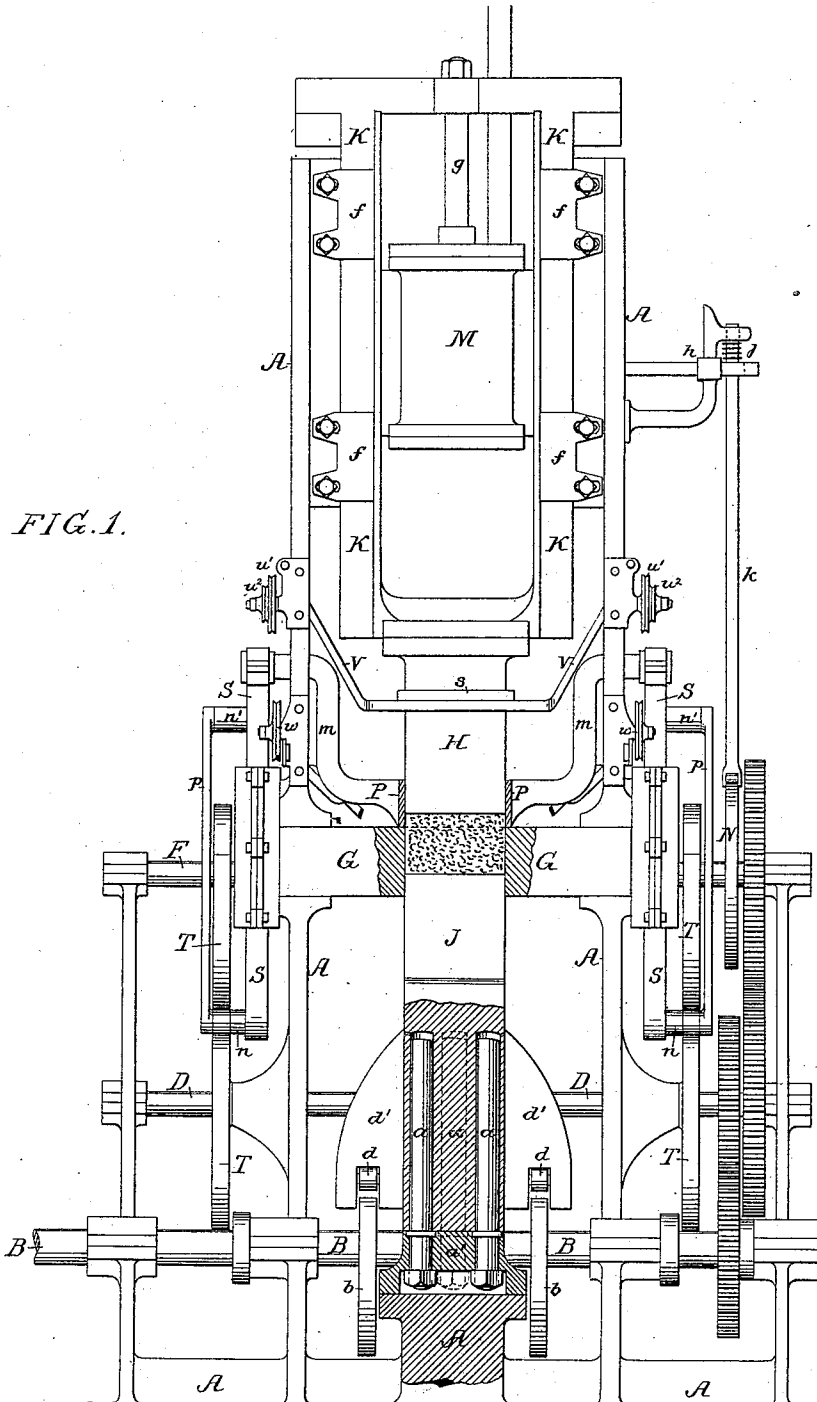

FIG. 1.

Witnesses:  
 William F. Davis  
 Harry Drury

Inventors:  
 C. I. Walker  
 and  
 F. J. Jervay  
 by their Attorneys  
 Howson and Sons

C. I. WALKER & F. J. JERVEY.  
PRESS FOR PLASTIC MATERIAL FOR BUILDING BLOCKS.

No. 323,757.

Patented Aug. 4, 1885.

FIG. 2.

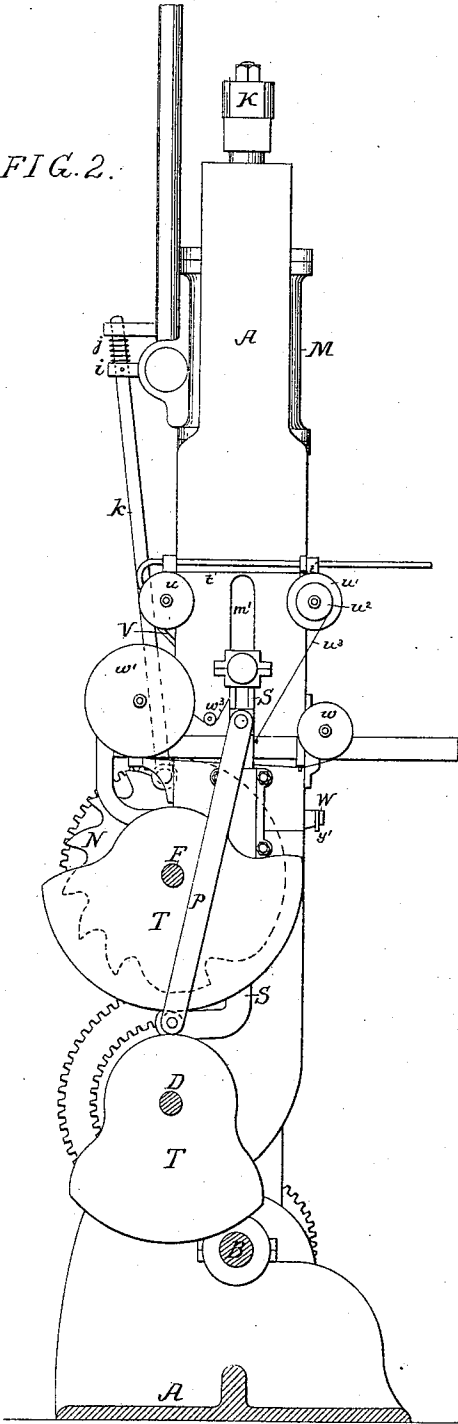
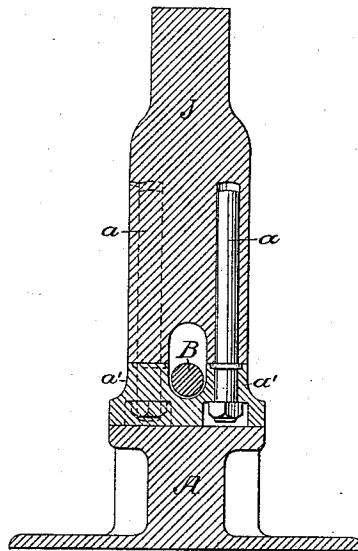

FIG. 6.



Witnesses:  
 William F. Davis  
 Harry Drury

Inventors:  
 C. I. Walker  
 and  
 F. J. Jervey  
 by their Attorneys  
 Howson and Co.

C. I. WALKER & F. J. JERVEY.

PRESS FOR PLASTIC MATERIAL FOR BUILDING BLOCKS.

No. 323,757.

Patented Aug. 4, 1885.

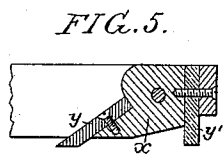
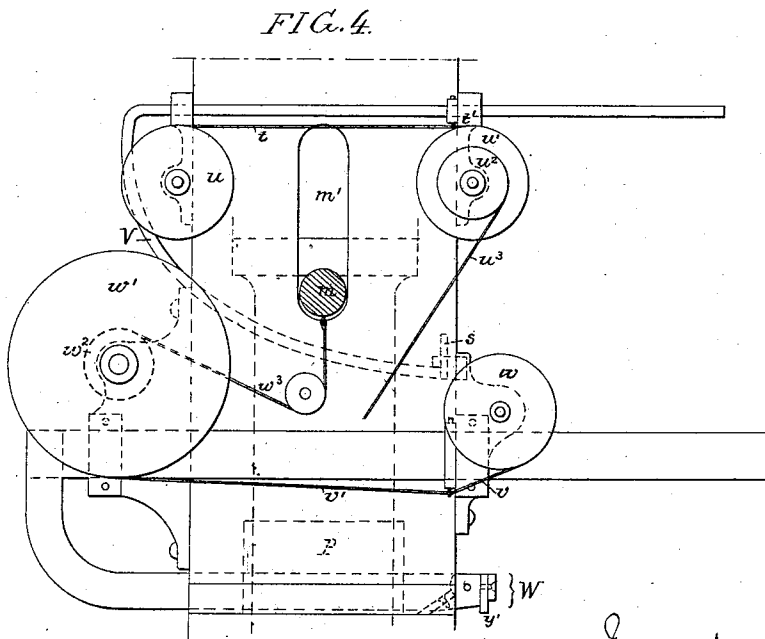
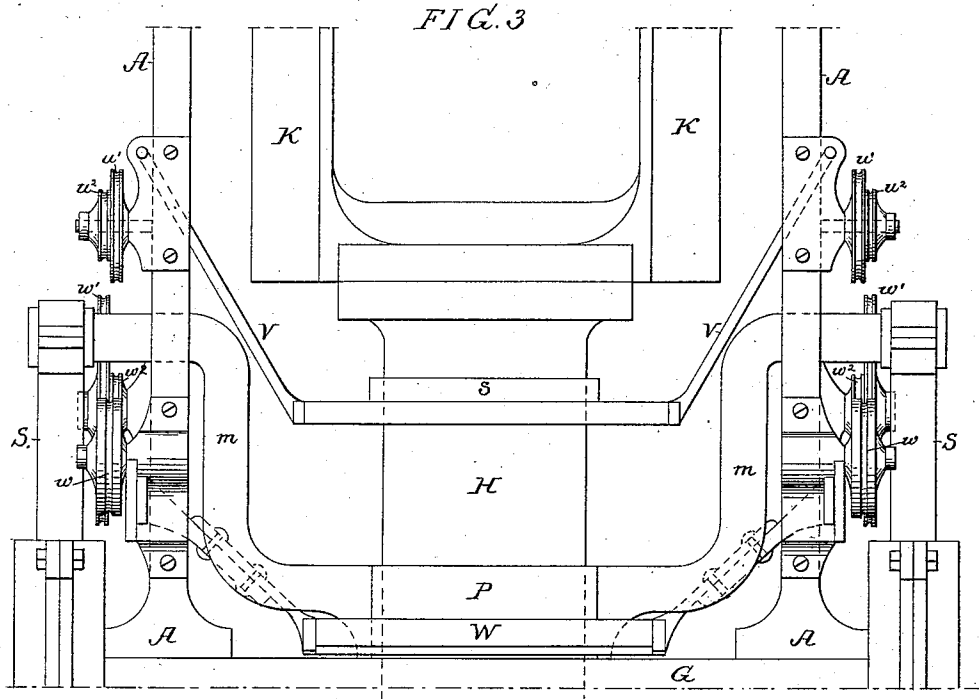

Witnesses:  
 William F. Davis  
 Harry Drury

Inventors:  
 C. I. Walker  
 and  
 F. J. Jervay  
 by their Attorneys  
 Howson and Low

# UNITED STATES PATENT OFFICE.

C. IRVINE WALKER AND FRANK J. JERVEY, OF CHARLESTON, S. C., ASSIGNORS TO THE STONEY LANDING COMPANY, OF SAME PLACE.

## PRESS FOR PLASTIC MATERIAL FOR BUILDING-BLOCKS.

SPECIFICATION forming part of Letters Patent No. 323,757, dated August 4, 1885.

Application filed March 16, 1885. (No model.)

*To all whom it may concern:*

Be it known that we, C. IRVINE WALKER and FRANK J. JERVEY, both citizens of the United States, and residents of Charleston, Charleston county, South Carolina, have invented certain Improvements in Presses for Plastic Material, of which the following is a specification.

Our invention relates to machinery for pressing, by percussion, plastic material into blocks for building or other purposes, the objects of our invention being to insure a thorough compacting of the material in the mold and the production of blocks with sharp clean edges, to provide for the ready discharge of the blocks from the mold, to permit the rapid operation of the machine, and to prevent the strain due to the blows of the plunger from injuriously affecting the working parts of the machine.

In the accompanying drawings, Figure 1 is a front view of our improved press for plastic material, part being in section; Fig. 2, a side view of the same, looking in the direction of the arrow, Fig. 1; Figs. 3 and 4, diagrams illustrating the construction of devices for operating the scraper and wiper plates; Fig. 5, a sectional view, on a larger scale, of the scraper; and Fig. 6, a detached sectional view of part of the machine.

A is the frame-work of the machine, to suitable bearings in which are adapted the operating-shafts, three of these shafts (lettered, respectively, B, D, and F) being shown in the drawings, although fewer shafts may be used, as described hereinafter.

The shaft B is the driving-shaft, and is geared by spur-wheels to the shaft D, similar wheels gearing the latter to the shaft F, so that all the shafts rotate at the same speed.

The mold-box is formed in a transverse plate, G, of the frame, and is adapted for the reception of the upper and lower plungers, H and J, between the ends of which the block is compressed in the mold. The plunger J is guided at the lower end upon a series of studs, *a*, secured to and projecting from pedestals *a'*, forming part of or directly connected to the foundation or base of the machine, as shown in Fig. 1, and said plunger is operated by

cams *b* on the shaft B, these cams acting upon anti-friction rollers *d*, carried by wings *d'* on the plunger J. The cams *b* are such that when the plunger J is at the limit of its descent it rests upon the pedestals *a'* and not upon the cams, so that the strain of the blows delivered upon the material in the mold is transmitted directly to the bed or foundation of the machine, and has no tendency to impair or destroy any of the working parts.

The upper plunger, H, is secured to the lower end of a frame, K, which is guided vertically in suitable bearings, *f*, on the frame A, these bearings being adjustable to compensate for wear. The upper end of the frame K is connected to the piston-rod *g* of a cylinder, M, which is secured to a suitable transverse bar of the frame A, and is provided with a valve—preferably a rotary valve—whereby steam or air under pressure may be admitted and exhausted from the cylinder, the steam or air being admitted under the piston, so as to cause the same to rise, and the weight of the piston-rod *g*, frame K, and plunger H causing them to fall when the steam or air is exhausted from the cylinder. The shank *h* of the valve-stem has an arm, *i*, upon which acts the rod *k*, the lower end of which is under the influence of a tappet-wheel, N, on the shaft F, a spring, *j*, serving to restore the arm *i* to its original position after it has been lifted by the action of the rod *k*, and the vibration of the arm *i* effecting such a movement of the valve as to alternately open the supply and exhaust port of the same. The number of strokes of the plunger H during each revolution of the shaft F is thus governed by the number of tappets on the wheel N, and the latter has a blank space of considerable length, as shown by dotted lines in Fig. 2, so that the hammer will be lifted and held in an elevated position long enough to permit the removal of the pressed block from the mold and the introduction of a fresh supply of material thereto.

It will be evident that a cam may be used instead of the tappet-wheel, and a weight instead of the spring *j*, and we therefore do not limit ourselves to the detailed construction of mechanism shown for operating the valve,

nor is any specific form of valve necessary, so long as it possesses the desired quickness of action.

We find that by using the cylinder and piston to elevate the plunger, and then allowing the same to drop, we can operate said plunger much more rapidly and with less expenditure of power than when cams are used for the purpose, the work of the machine being thus materially facilitated, while on the other hand the action of the plunger on the material in the mold is preferable, in many respects, to that of a plunger the impact of which is due to the pressure upon the piston, as in a steam-hammer. In order to distinguish our plunger-operating device from a steam-hammer, therefore, we have termed said device a "lifting-ram."

The material is directed to the mold, when the plunger H is elevated, by means of a feed-box, P, opposite arms *m* on which project through vertical slots *m'* in the sides of the frame of the machine, and are connected to the upper ends of rods S, guided in suitable boxes on the side frames, the lower end of each rod having a projecting stud, *n*, an anti-friction roller on which is contained between cams T T on the shafts D and F, these cams being so formed as to correspond with each other and impart a rapid motion to the feeding-box, with a long dwell at the upper and lower limits of its movement. The cams T are so timed in respect to the tappets or cams which operate the valve of the lifting-ram that the feed-box will be raised from the mold before the plunger strikes the last blow upon the material, and there is a slight dwell before the plunger is raised to deliver the last blow, so that the feed-box rises in advance of the plunger.

The lower ends of the rods S are bent rearward, so as to bring the studs *n* in line with the shafts D and F, and in order to brace the rods the studs *n* are connected to studs *n'*, near the upper ends of said rods, by means of bars *p*.

It should be understood that the means for operating the feed-box are capable of material modification within the limits of our invention. For instance, instead of two shafts with two cams for each rod S, a single shaft, with slotted or grooved cam, may be used; or the box may be moved in one direction by a cam, and in the opposite direction by a weight or spring.

In the operation of our machine, the amount of material supplied to the feed-box is somewhat in excess of that necessary to fill the mold when properly compacted; hence after the upper plunger, H, has delivered upon the material the number of blows necessary to thoroughly compact the same, a portion of the material is still contained in the feed-box. Before the plunger H delivers its last blow the feed-box rises, this movement being more rapid than that of the plunger, so that the latter presses the surplus material out of the feed-

box, and when the plunger has been elevated a scraper is drawn across the top of the mold, so as to shave off the surplus material in the mold, which, however, is not compressed therein by the blow, as it has been already compacted to the full extent, the final blow of the plunger serving only to perfect the surface of the block and insure the formation of sharp clean edges upon the same. Before descending to deliver the last blow, the lower face of the plunger H is cleaned of all adhering particles by means of a wiper drawn across the same.

In Figs. 3 and 4 we have shown mechanism which may be employed for operating the wiper and scraper; but our invention is not limited to the mechanism there shown, the latter being introduced simply to show one way in which the said wiper and scraper may be operated.

The wiper *s* consists of a transverse bar carried by a bent frame, V, adapted to suitable guides on the frame. To a collar, pin, or other suitable attachment on the opposite bars of this frame are connected one end of each of two cords, *t t'*. The opposite end of the cord *t* is connected to a spring-drum, *u*, hung to a bearing on the frame A, and the opposite end of the cord *t'* is connected to a pulley, *u'*, the shaft of which has another pulley, *u''*, to which is connected one end of a cord, *w''*, the opposite end of the latter being attached to the rod which lifts the feed-box. As the hammer rises to deliver the next to the last blow, the wiper *s* is drawn against the side of the hammer, owing to the action of the spring-drums *u* upon the cords *t*, connected to the guided bars of the wiper-frame, the cords *w''* having been slackened by the rise of the feed-box. As soon as the bottom of the hammer is in line with the upper edge of the wiper the latter is drawn rapidly across the face of the hammer, and the latter is cleaned of any material which may be adhering thereto. As the hammer rises again after the last blow, the feed-box falls, the cord *w''* is subjected to tension, and the pulleys *u''* and *u'* are turned so as to wind up the cord *t'* and effect the restoration of the wiper, which remains in the position shown in Fig. 3 until the feed-box is again raised. A similar arrangement of cords *v*, *v'*, and *w''*, pulleys *w'* *w''*, and spring-drums *w* is used for causing the reciprocation of the scraper W.

As the feed-box rises, the cord *v'* is wound upon the pulley *w'* and the drum *w* is turned, so as to wind up its spring, the recoil of which effects the backward movement of the scraper on the descent of the feed-box. The scraper is constructed as shown in Fig. 5, and consists of a pivoted block, *x*, having on one face a blade, *y*, of metal or other rigid material, and on the other face a strip, *y'*, of rubber, leather, or other like yielding material. The scraper is drawn across the top of the mold as the feed-box rises, and the blade *y* removes the surplus material which has been left by the feed-box; but as the block *x* is free to tilt on

the backward movement of the scraper, the strip *y* is during this movement caused to bear upon and cleanse the upper surface of the lower plunger, *J*, which has meantime been raised slightly above the surface of the mold, in order to permit the ready removal of the pressed block.

We have shown in the drawings a mold with a single opening; but it will be evident that the mold may have two or more openings, if desired, the number of plungers or the molding extremities thereof being increased to accord with the increased number of openings in the mold.

As before remarked, we use the term "lifting-ram" to distinguish our machine from those in which the air or steam under pressure acts upon the hammer or plunger to deliver the blow, and the term is also used to distinguish our improved method of operating the plunger from the usual plan of lifting the same by cams, tappets, or toes upon a rotating shaft.

We claim as our invention—

1. A press for plastic material, in which are combined a mold, a dropping plunger, and a plunger-lifting ram acted upon by fluid under pressure, substantially as specified.

2. A press for plastic material, in which are combined a fixed mold, a movable ejector-plunger, a dropping compacter-plunger, and a plunger-lifting ram acted upon by fluid under pressure, substantially as set forth.

3. A press for plastic material, in which are combined a mold, a compacting-plunger, and a feed-box movable vertically from and toward the mold and in line with the same, substantially as specified.

4. A press for plastic material, in which are combined a mold, a compacting-plunger, a feed-box movable from and toward the mold, and a cut-off or scraper working between the mold and feed-box when the latter is moved away from the mold, substantially as specified.

5. The combination, in a press for plastic material, of a mold, a compacting-plunger, a feed-box movable vertically from and toward the mold, and operating mechanism whereby the feed-box is moved away from the mold, while the compacting-plunger presses the surplus material from said feed-box, all substantially as set forth.

6. The combination of the mold, the lower ejector-plunger, the upper compacting-plunger, the feed-box movable from and toward the mold, and the scraper working between the mold and feed-box, all substantially as specified.

7. The combination of the mold and the compacting-plunger with a scraper and the wiper independent thereof, and movable across the acting face of the plunger to clean the same, all substantially as specified.

8. The combination of the mold, the ejector-plunger, the compacting-plunger, the feed-box movable from and toward the mold, and the scraper working between the mold and the feed-box, and having a strip whereby the face of the ejector-plunger is cleaned on the backward movement of the scraper, all substantially as set forth.

9. The combination, in a press for plastic material, of the mold, the compacting-plunger, and the ejecting-plunger, the latter having a seat upon the frame of the machine during the compacting of the block in the mold, all substantially as set forth.

In testimony whereof we have signed our names to this specification in the presence of two subscribing witnesses.

C. IRVINE WALKER.  
FRANK J. JERVEY.

Witnesses:

H. LILIENTHAL, Jr.,  
U. R. JOHNSON.