



US006339591B1

(12) **United States Patent**
Migimatsu

(10) **Patent No.:** **US 6,339,591 B1**
(45) **Date of Patent:** **Jan. 15, 2002**

(54) **SYSTEM AND METHOD FOR TRANSMITTING VOICE MESSAGES THROUGH THE INTERNET**

5,689,550 A * 11/1997 Garson et al. 379/89
5,768,513 A * 6/1998 Kuthyar et al. 395/200.34

(75) Inventor: **Taka Migimatsu**, San Rafael, CA (US)

FOREIGN PATENT DOCUMENTS

(73) Assignee: **Eletel, Inc**, San Francisco, CA (US)

WO WO 97/28628 * 7/1997

(*) Notice: Subject to any disclaimer, the term of this patent is extended or adjusted under 35 U.S.C. 154(b) by 0 days.

OTHER PUBLICATIONS

(21) Appl. No.: **08/831,790**

C. Yang, "INETPhone: Telephone Services and Servers on Internet," <http://ds.internic.net/rfc/rfc1789.txt>, pp. 1-6, Apr. 1995.*

(22) Filed: **Apr. 9, 1997**

* cited by examiner

Related U.S. Application Data

(60) Provisional application No. 60/033,416, filed on Nov. 15, 1996.

(51) Int. Cl.⁷ **H04L 12/56**

(52) U.S. Cl. **370/352; 370/401; 379/220; 709/331**

(58) **Field of Search** 370/352, 358, 370/400, 401, 402, 403, 404, 405, 406, 465, 463, 356, 353, 354, 389; 395/227, 228, 229, 237, 238, 249, 250; 358/425; 379/219, 220, 88.17, 88.18, 88.19; 709/249, 250, 251, 311, 312

Primary Examiner—Ricky Ngo

(74) *Attorney, Agent, or Firm*—Townsend and Townsend and Crew

(57) **ABSTRACT**

A system for transmitting messages from a caller location to a receiver location using a plurality of computers **11** each coupled to another such as the Internet. The system also has a plurality of access devices **13a-13l**, which are coupled to the network through a telecommunication line. These access devices include computers, workstations, and the like. Each access device includes a voice conversion board **17, 19** into digital data for transmission through the network.

(56) **References Cited**

U.S. PATENT DOCUMENTS

5,608,786 A * 3/1997 Gordon 370/401

19 Claims, 12 Drawing Sheets

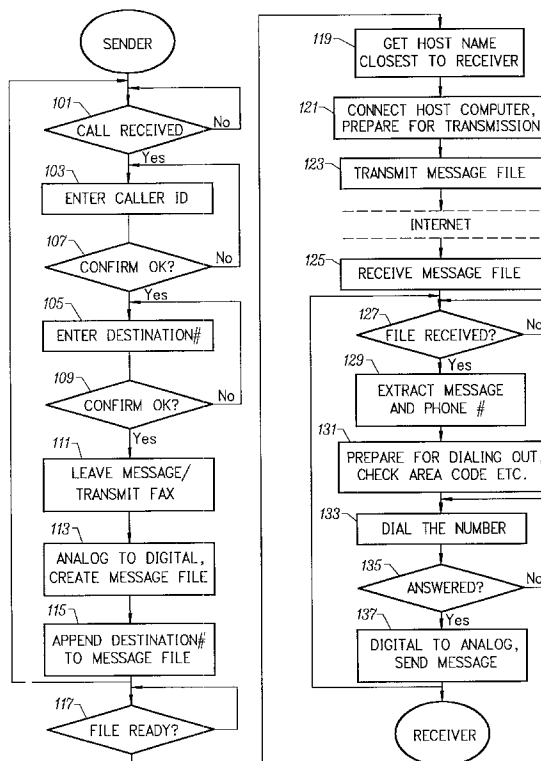

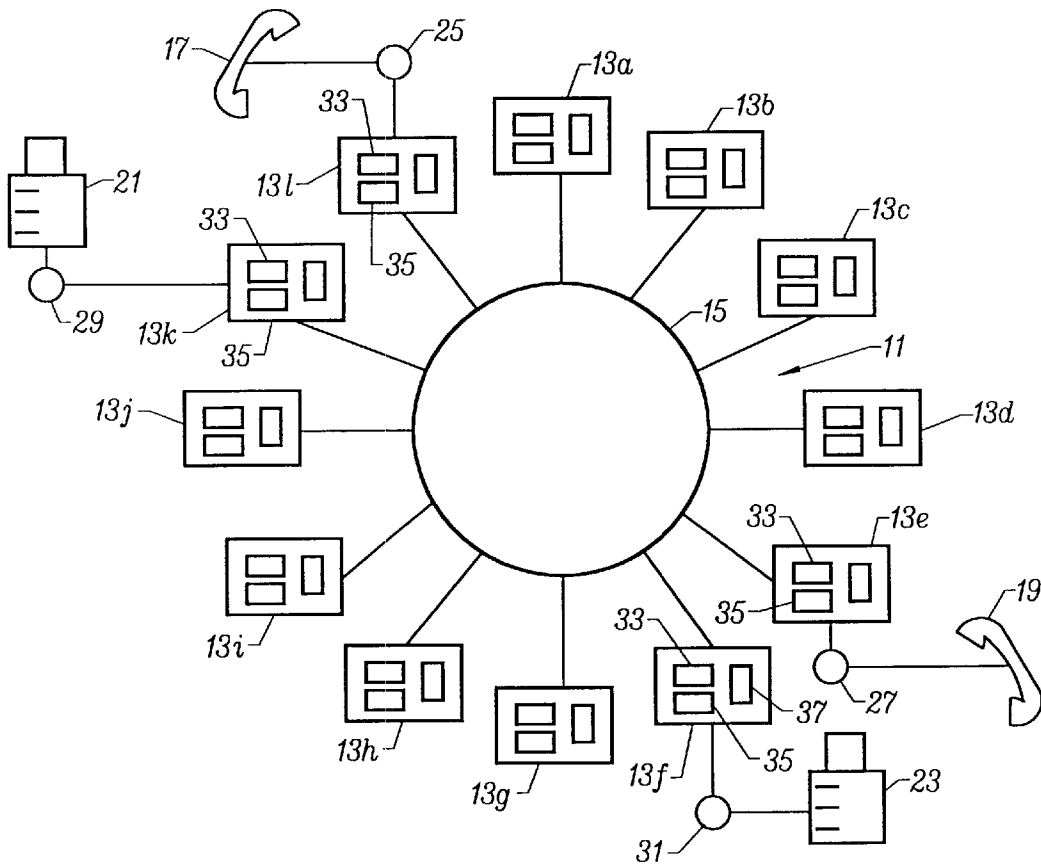

FIG. 1

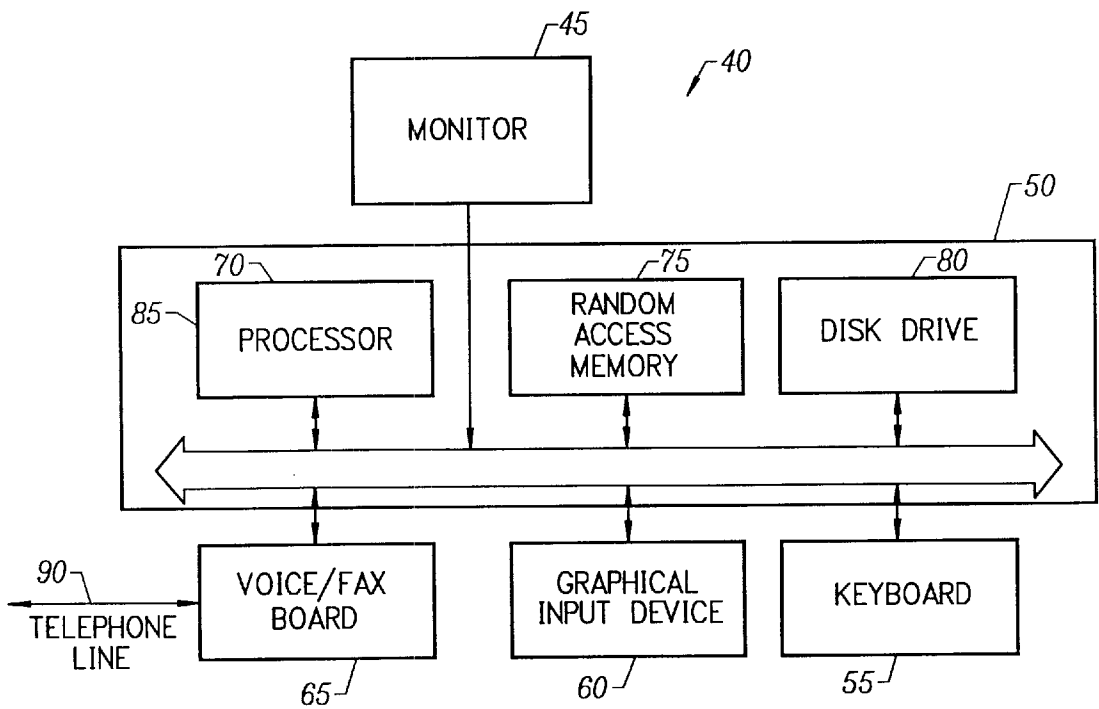

FIG. 2

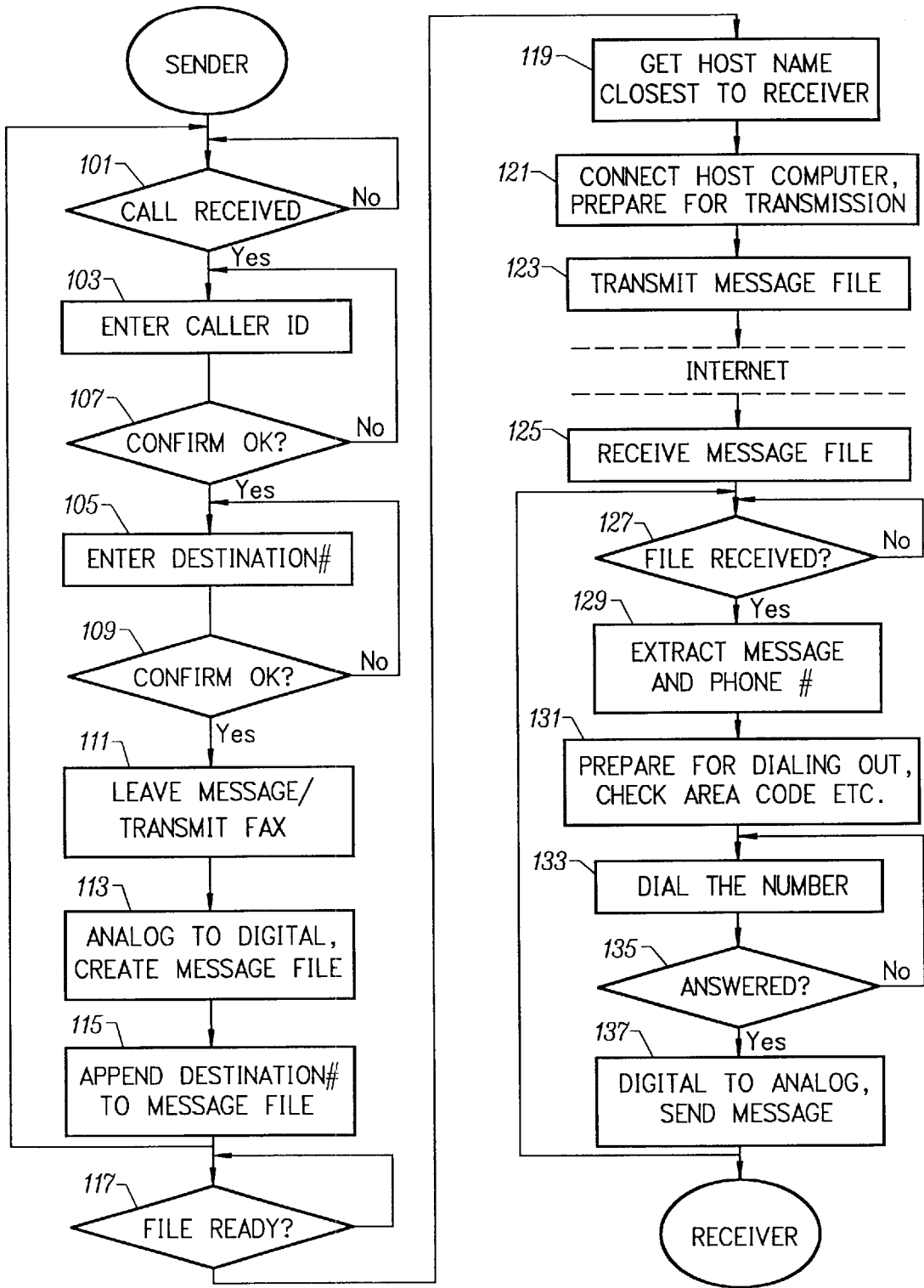

FIG. 3

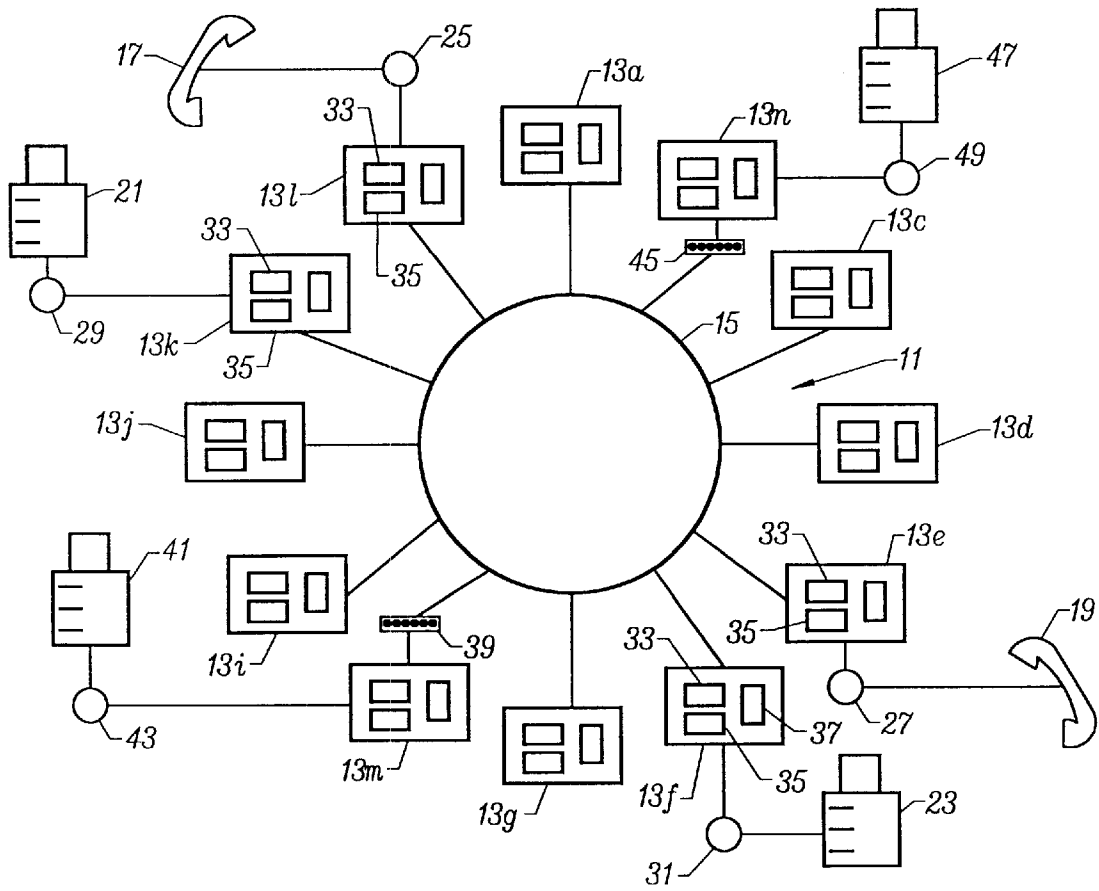

FIG. 4

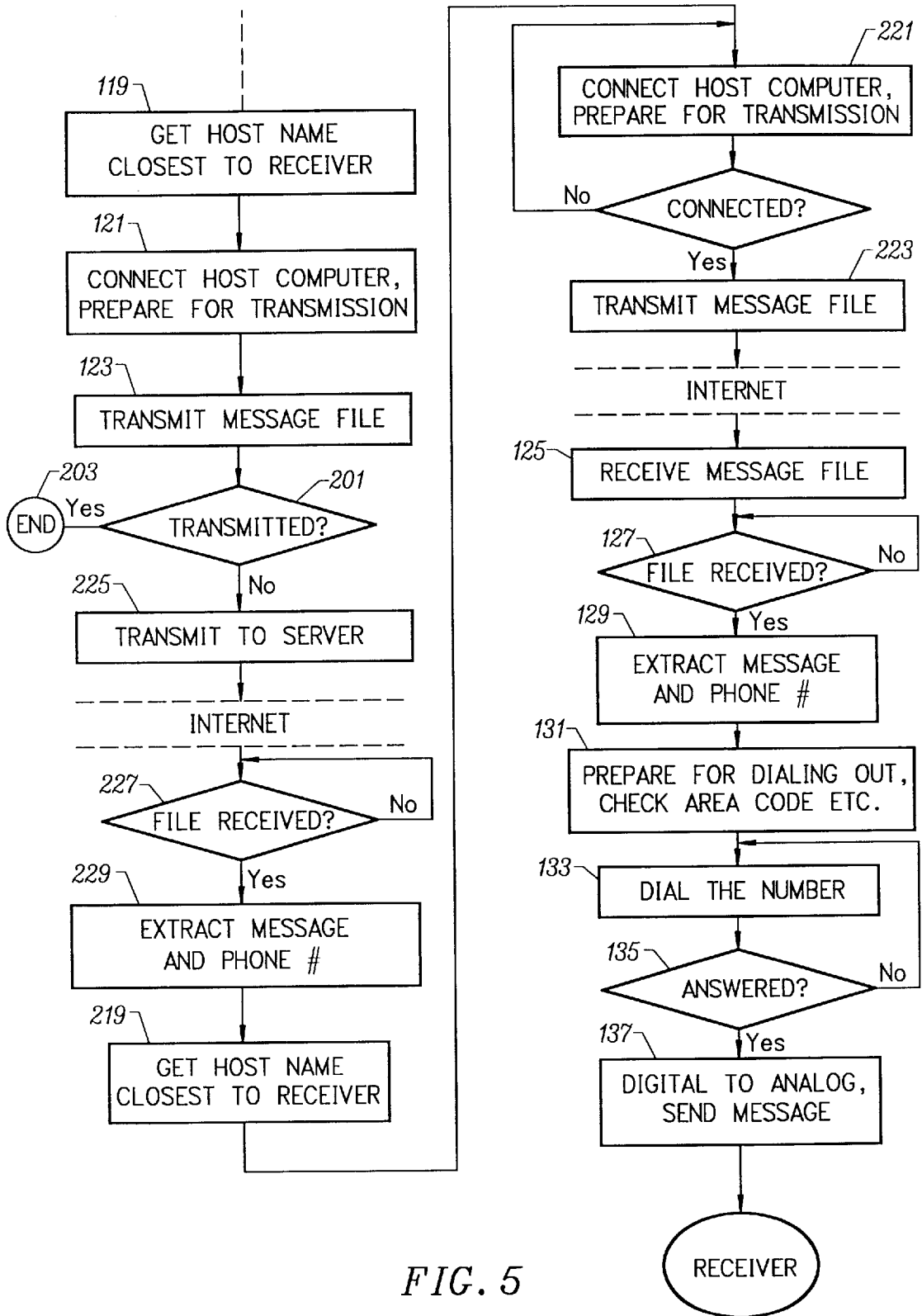

FIG. 5

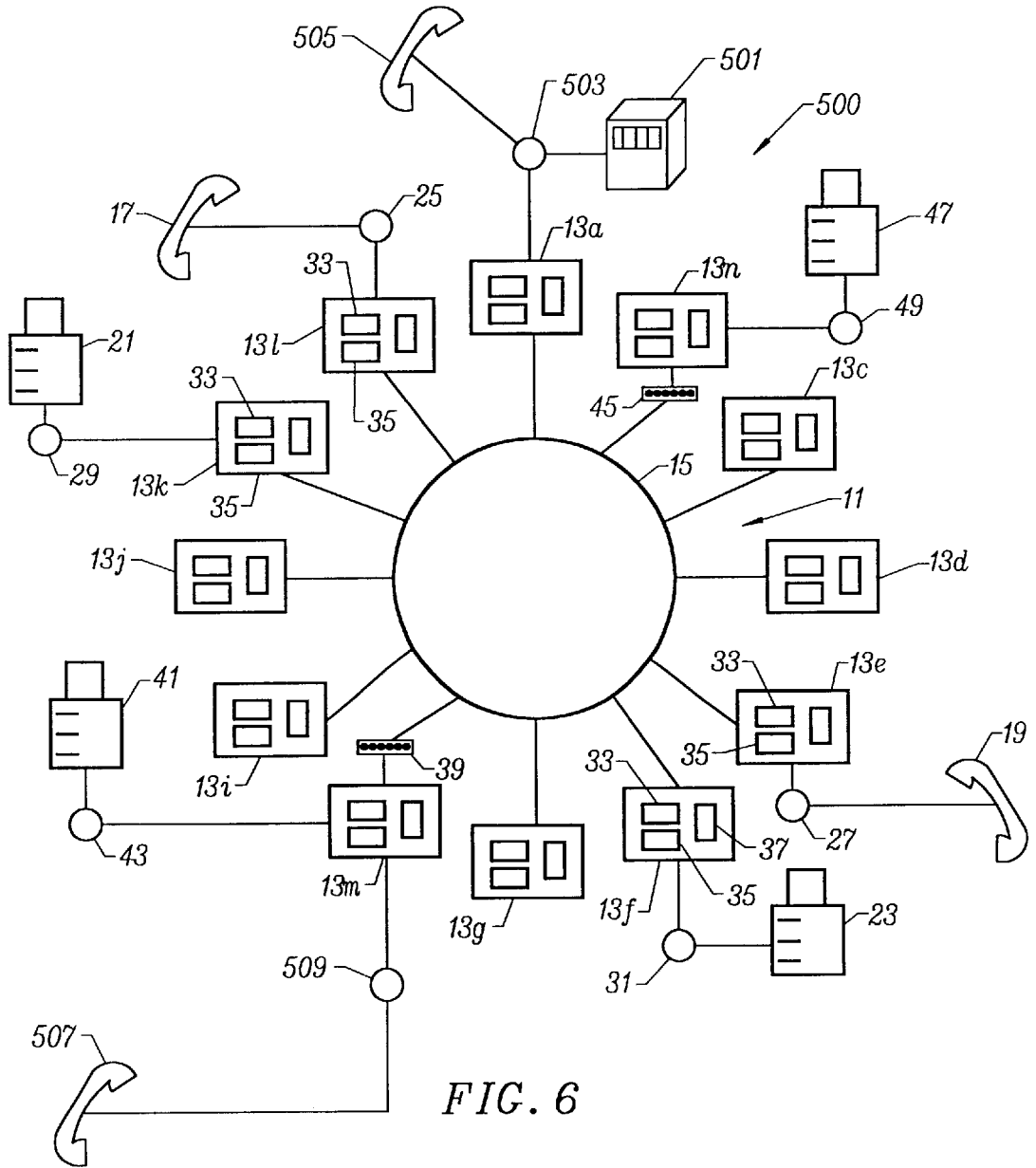

FIG. 6

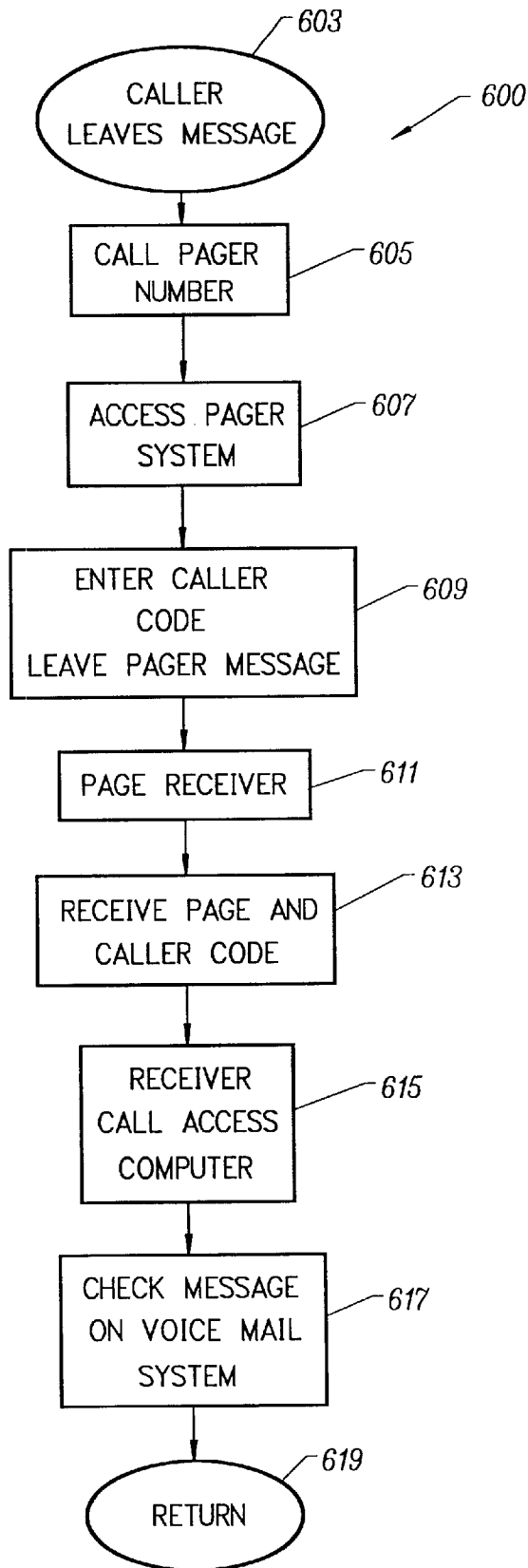

FIG. 7

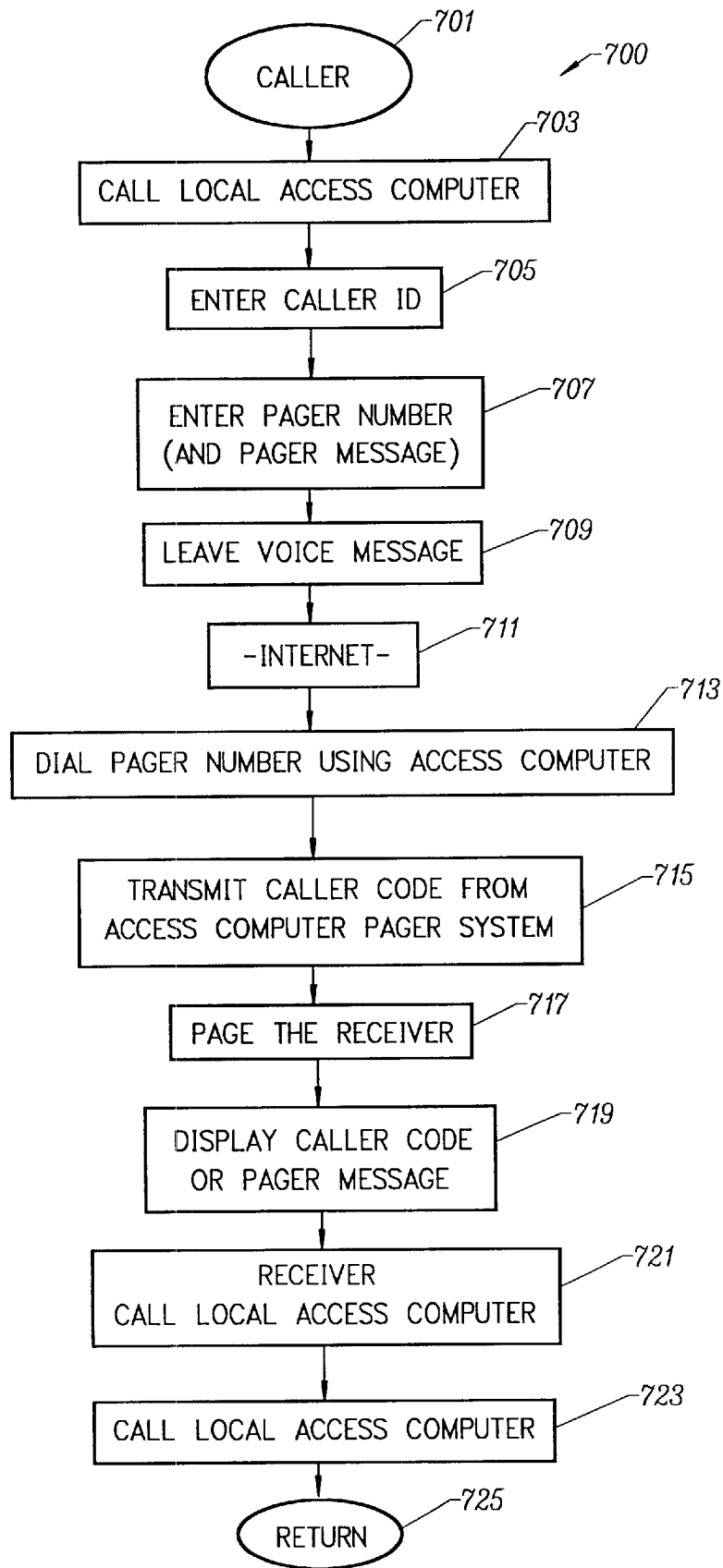

FIG. 8

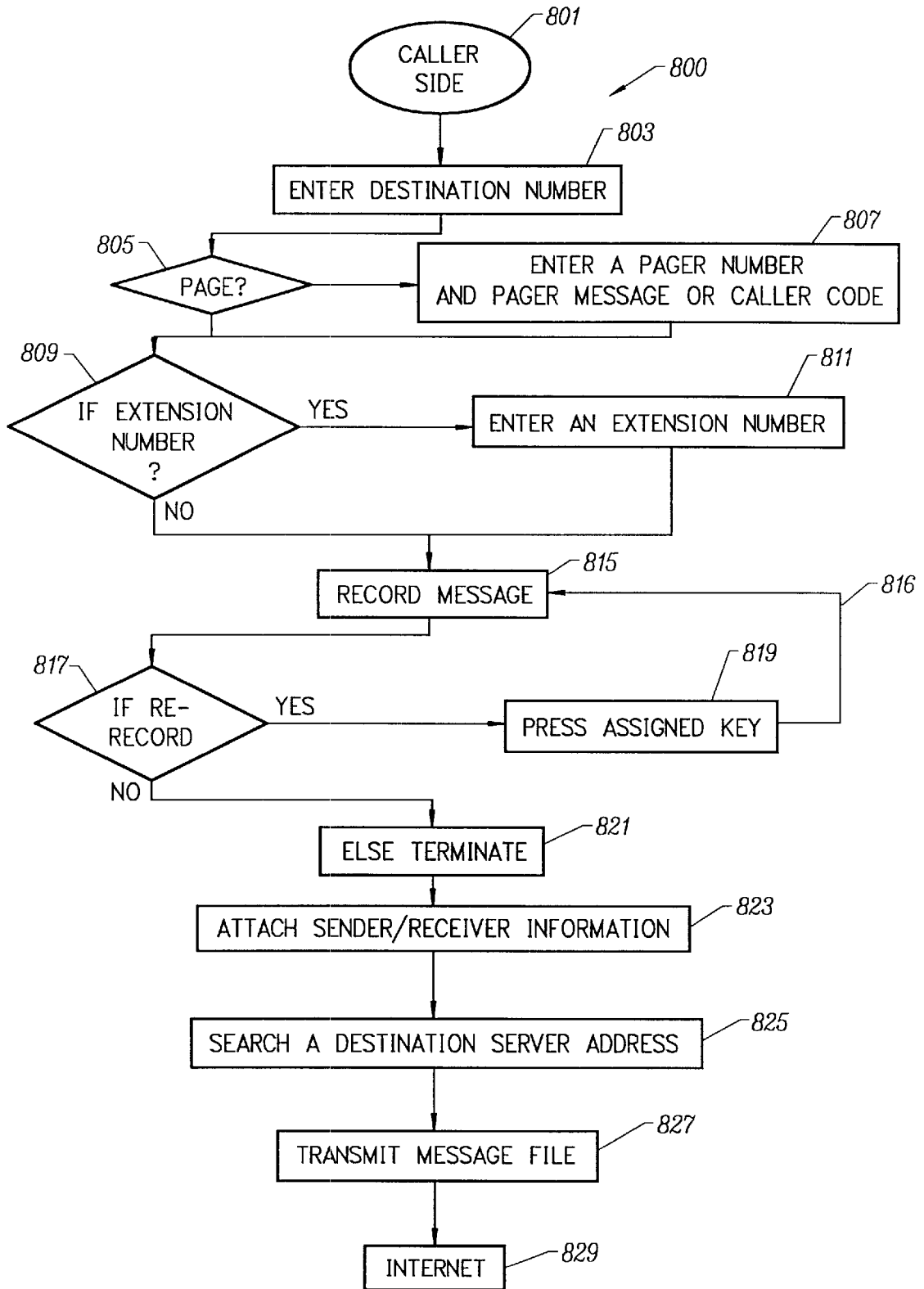
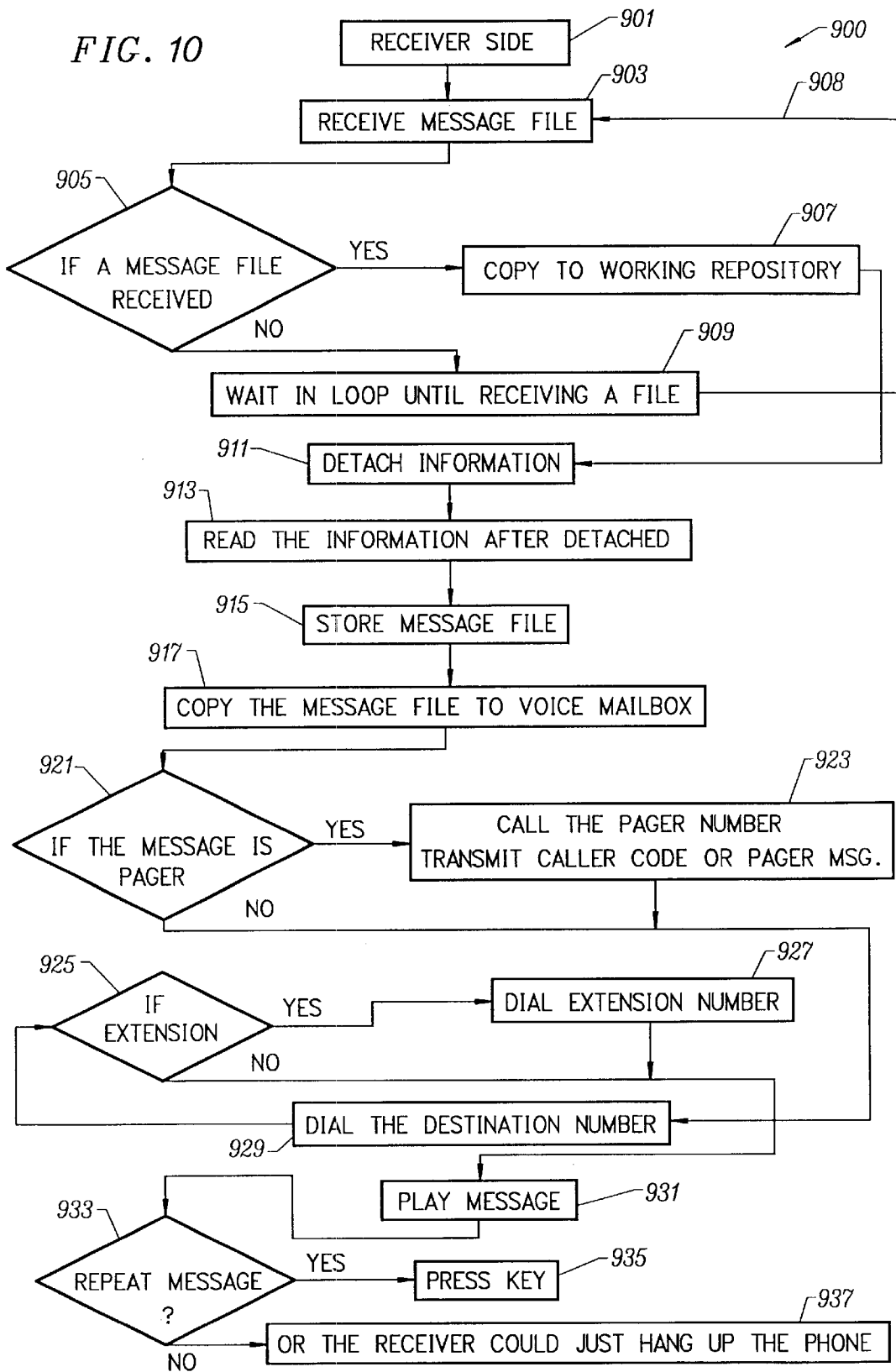

FIG. 9



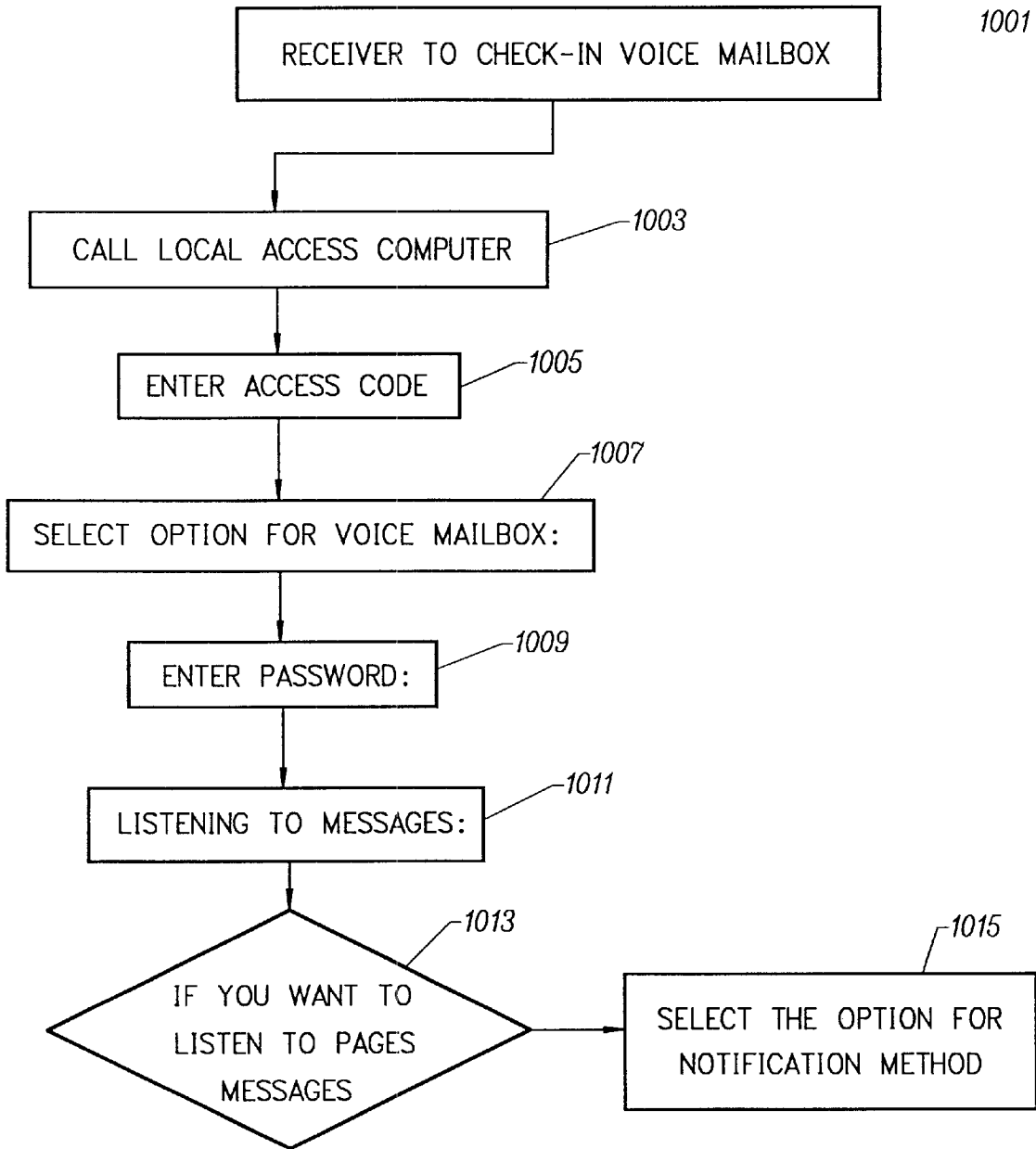

FIG. 11

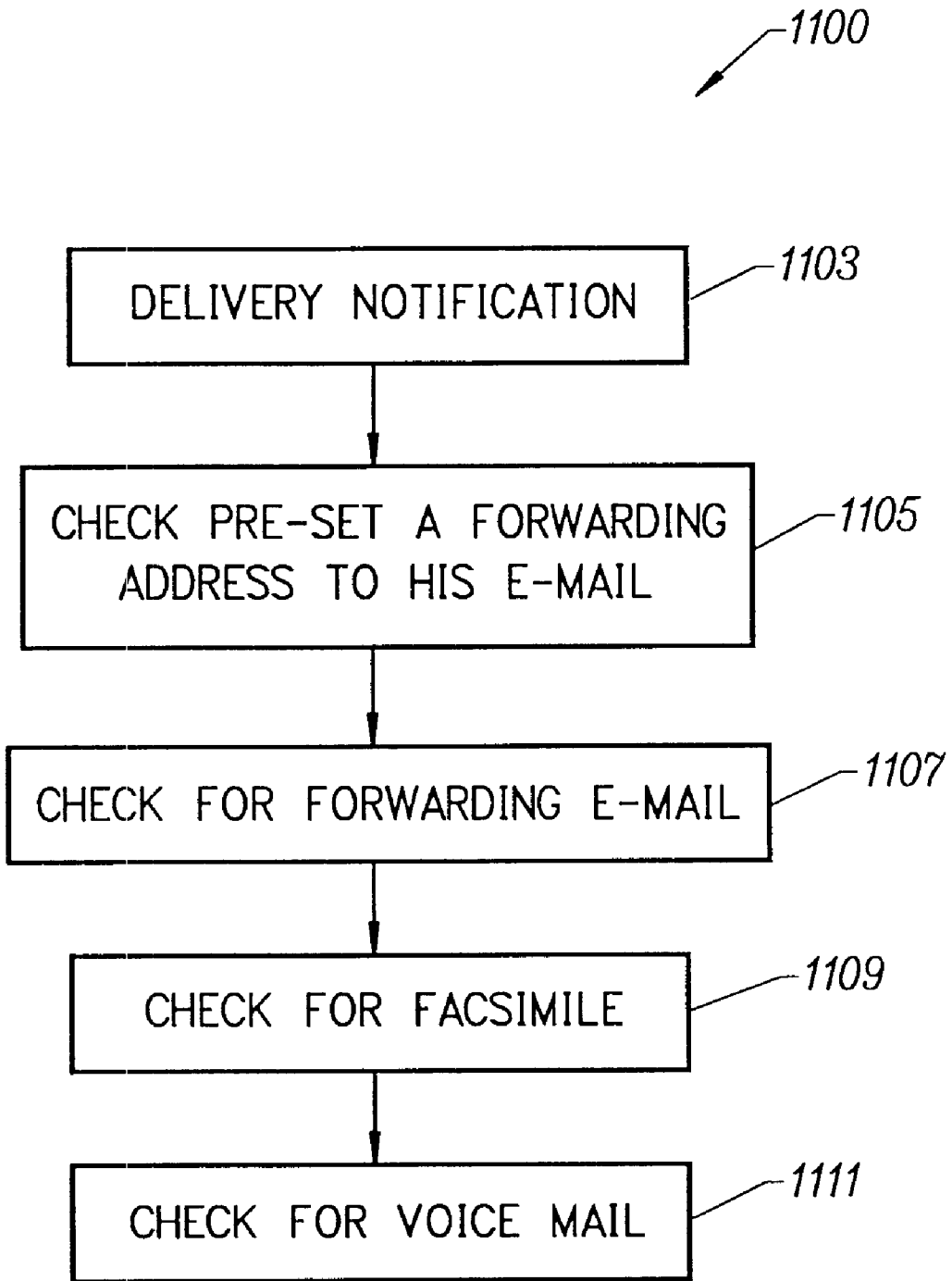

FIG. 12

SYSTEM AND METHOD FOR TRANSMITTING VOICE MESSAGES THROUGH THE INTERNET

This application claims benefit to Provisional Application No. 60/033,416 filed Nov. 15, 1996.

BACKGROUND OF THE INVENTION

The present invention relates generally to communication techniques. The techniques include a system and method of communicating telephone messages, such as voice, paging, and facsimile (fax) messages, by way of the Internet or any other network system having some form of transmission control protocol and not necessarily the TCP/IP protocols. More specifically, the invention relates to communicating such messages from and to stations which need not themselves require a computer or, in the case of voice transmission, any other form of central processing unit or digital signal processor.

Conventional telephone and facsimile communication involves real time communication and is often directly between calling and receiving parties. These conventional techniques generally require a telephone and/or a facsimile machine. As numerous countries industrialize, telephones and facsimile machines are becoming more available worldwide. As the number of users increases, the amount of traffic generated by telephones and/or facsimile machines also increases proportionately. Telephone calls between users in different countries such as Japan and the United States, however, continue to be quite expensive. For instance, a typical week-long business trip in Japan from the United States can incur hundreds of U.S. dollars worth of telephone services. Increased traffic generated by telephones and/or facsimile machines also leads to "jams" in the communication lines, thereby leading to calls that never reach the receiving party.

In attempts to resolve some of these limitations, communication techniques have been proposed to use the Internet as a real time communication means. These communication techniques generally require at least two computers, where one computer is at the caller site and the other computer is at the receiver site. These computers, however, require a modem, which is connected to the Internet using a TCP/IP transmission protocol. A limitation with these techniques is that computers connected to the Internet are not generally available at easy to use locations. In addition, the servers on the Internet often malfunction, which lead to less than real time communication between calling and receiving parties.

From the above, it can be seen that a technique for communication that is easy-to-use and cost effective is highly desirable.

SUMMARY OF THE INVENTION

According to the present invention, a technique for providing voice messages and paging functions using a system of "networked" computers is provided. This technique, including a method and system, uses existing telephones and pagers which are coupled to the Internet system for transmitting and receiving voice messages to a receiver from a caller.

In a specific embodiment, the present invention provides a system for transmitting messages from a caller location to a receiver location using a plurality of computers each coupled to another such as the Internet. The system also has a plurality of access devices, which are coupled to the network through a telecommunication line. These access

devices include computers, workstations, and the like. Each access device includes a voice conversion board for converting a voice message from a telephone device into digital data for transmission through the network.

In an alternative embodiment, a method for telecommunication is provided. The method includes transmitting information from a first telephone device at a receiver location in a first service area through a telecommunication medium (i.e., telephone line, etc.), and receiving at the first service area the information in a first access device. The method also includes converting the information into a digital signal, and transmitting the digital signal over the Internet to a second access device at a second service area. Further steps of converting the digital signal into data for storage into a memory, and retrieving the data from the memory at the second service area using a second telephone device are provided.

A system for transmitting messages from a caller location to a receiver location using a paging system is also provided according to the present invention. The system has a plurality of computers, each of the computers being coupled to each other through a network such as the Internet. The system also has a plurality of access devices which are each coupled to the network through a telecommunication line. A paging device is also provided. This paging device is coupled to the access device using a paging system, which is adapted to receive paging data from a caller which will be sent to a receiver. The access device includes a processor coupled to a memory. The processor is also coupled to a voice conversion board for converting a voice message from a telephone device into digital data for transmission through the network. The processor also oversees receiving first paging data from the caller and transmitting paging data to the receiver through the telecommunication line.

In yet an alternative embodiment, a method of telecommunication using a paging system is provided. The method includes receiving at an access computer voice message data and paging data from a telecommunication line coupled to the Internet, where the paging data includes a paging number and a caller code. The method also includes converting the paging data and the caller code into telephone key codes at the access computer and calling a paging unit at a receiver location using a paging system, and transmitting the caller code to the paging unit at the receiving location, which calls the receiver using a local number.

Benefits of the invention include an easy-to-use voice mail and paging system. In particular, a caller of the present invention can rely upon almost any telephone to leave a voice mail for a receiver at a non-local mailbox using a local call or the like, which reduces costs associated with any conventional long distance telephone calls. Additionally, a caller can also page and leave a voice mail for a receiver at a non-local mailbox using a local call, further reducing costs associated with conventional long distance telephone calls. The page attracts the attention of the receiver, who can then call at that time, or some other time. Since these calls are generally all local in nature, the caller does not incur the costs associated with long distance calls. These long distance calls can be quite substantial when calling from countries outside the United States such as Japan, Korea, Europe, and others to the United States, for example.

The present invention achieves these benefits and others in the context of known telephone and computer technology. A further understanding of the nature and advantages of the present invention, however, may be realized by reference to the latter portions of the specification and attached drawings.

BRIEF DESCRIPTION OF THE DRAWINGS

FIG. 1 is a simplified block diagram of access computers coupled to a network of computers according to an embodiment of the present invention;

FIG. 2 is a block diagram of a system 40 according to a preferred embodiment of the present invention.

FIG. 3 is a simplified flow chart of a process according to an embodiment of the present invention;

FIG. 4 is a simplified block diagram of an alternative embodiment of access computers coupled to a network of computers according to an embodiment of the present invention;

FIG. 5 is a simplified flow chart of a further process according to still another embodiment of the present invention;

FIG. 6 is a simplified block diagram of access computers coupled to a network of computers and a paging system according to the present invention;

FIG. 7 is a simplified flow chart of a process using the paging system with the access computers according to the present invention;

FIG. 8 is a simplified flow chart of an alternative process using the paging system with the access computers according to the present invention; and

FIGS. 9–12 are simplified flow chart diagrams of system software according to embodiments of the present invention.

DESCRIPTION OF THE SPECIFIC EMBODIMENTS

FIG. 1 is a simplified representation of a network of computers, e.g., Internet, etc. The simplified representation of computers is merely an illustration and should not limit the scope of the claims defined herein. The network of computers 11 can be the Internet 11. The Internet includes representative computers 13*a* through 13*l* interconnected with each other, as well as with many other computers (not shown), by means of the usual telephone lines and/or gateways 15. Each of the computers 13*a* through 13*l* serve as an access point in the system of the invention. The computers are merely illustrative, there can be hundreds, thousands, or even millions of these access point computers or access devices. The computers can be any suitable computer or workstation capable of coupling to the Internet. Examples of these computers include personal computers, computers sold under the tradename of Apple™, workstations, network computers, and others. These computers can also run a variety of operating systems and have various browsers or the like. Additional features of the computer will be discussed by way of the description below.

In addition to the access point computers 13*a* through 13*l*, there are shown representative telephone sets 17 and 19 and fax machines 21 and 23. The telephone 17 may be selectively coupled through its own central office 25, and possibly others, to various telephone units throughout the world. Similarly, the telephone 19 and faxes 21 and 23 may be selectively coupled through their respective central stations 27, 29 and 31 to other telephone units. The telephone units can be any device capable of transmission of voice signals into the telephone lines of telephone companies. These telephones include conventional analog phones, digital phones, computer phones, cellular phones, and the like. As for the facsimile machines, they can be almost any suitable machine capable of transmitting facsimile data via telephone lines. The telephones and facsimile machines are merely illustrative, literally hundreds, thousands, millions, and even billions of these units may be coupled to the access point computers.

So that all of the access computers 13*a* through 13*l* are capable of communicating on the Internet, they should each usually include a modem. So that computers 13*l*, 13*k*, 13*e*, 13*f*, for example, can communicate with telephones 17, 19, and fax 21, 23, they should each include a voice/fax board 33. The voice/fax board can be a single unit or multiple units, depending upon the application. An example of a preferred voice/fax board is one sold by a company called Rhetorix, Model RDSP. Of course, other boards can be used depending upon the application.

In addition, each of the access point computers 13*a* through 13*l* includes two types of control, one for telephone/fax communication and one for Internet communication. Such controls are known in the art and are software controllable, but can be hardware controllable too. Furthermore, each of the access computers 13*a* through 13*l* should be capable of performing the functions of a host computer; that is, it should be capable of transmitting and receiving data from and to other access computers by using a communication protocol. In order for the system to operate automatically, at least one access computer must be a server in the sense that it has a dedicated Internet connection. If non-automatic operation is acceptable, no server at all is necessary so long as both the sending and receiving access computers and their modems are up and running at the time of transmission.

FIG. 2 is a block diagram of a system 40 according to a preferred embodiment of the present invention. System 40 includes a monitor 45, a computer 50, a keyboard 55, a graphical input device 60, and a voice/fax board 65. Computer 50 includes familiar computer components such as a processor 70, and memory storage devices, such as a random access memory (RAM) 75, a disk drive 80, and a system bus 85 interconnecting the above components. A telephone line 90 is coupled to voice/fax board 65.

A mouse is but one example of a graphical input device, also known as a pointing device, a trackball is another. RAM 75 and disk drive 80 are examples of tangible media for storage of computer programs such as embodiments of the herein described methods. Other types of tangible media include floppy disks, removable hard disks, optical storage media such as CD-ROMS and bar codes, and semiconductor memories such as flash memories, read-only-memories (ROMS), and battery-backed volatile memories.

In a preferred embodiment, System 40 includes a IBM PC compatible computer having a '586-class based microprocessor, such a Pentium™ from Intel Corporation, running WindowsNT™ from Microsoft Corporation, and Callex™ software from Tokis Inc. Voice/fax board 65 is preferably a RDSP board from Rhetorix. Inc.

FIG. 2 is a representative of one type of system embodying the present invention. It will be readily apparent to one of ordinary skill in the art that many system types, hardware and software configurations are suitable for use with the presently described embodiments.

Referring to FIGS. 1 and 3 together, the operation of a system in accordance with the invention may be better understood. This operation is merely an example and should not limit the scope of the claims. One of ordinary skill in the art would recognize other modifications, variations, and alternatives.

In an embodiment, when a user of telephone 17, located for instance in the United States in the "415" telephone area code and the "472" service area, desires to send a voice mail message to someone in London, England having the telephone number 44-181-456-1234, he need merely telephone an access computer 13*l* in his own local telephone area.

5

The access computer 13/ is configured to periodically operate in its telephone/fax control mode and, in that mode, to poll the incoming telephone lines to determine whether a call is being received as shown in FIG. 3 at step 101. When the incoming call from telephone 17 is recognized, the program configuration of the computer 13/ causes to be generated a recognizable tone signal or a prerecorded or digital voice statement asking the caller to identify himself, step 103, and to provide the destination telephone number, including all necessary country and area codes, step 105.

In response to these inquiries, the caller need merely key the requested identification and destination information through his telephone handset. Upon confirmation of valid responses to these inquiries, steps 107 and 109, another recognizable tone signal or prerecorded or digital voice statement may be generated asking the caller to then speak the voice message or to start the fax to be forwarded to the destination number, step 111. The caller then merely speaks his message.

The caller's message is received by the access computer 13/ through its voice/fax board 33 where it is converted from analog to digital format, creating a message file, step 113. The destination telephone number is appended to the message file, step 115. In the event that no country or area code was keyed in, indicating a "local" message, the access computer will add default country and/or area codes for its own location. The message file is then stored in an outgoing repository memory 35 in the access computer 13/ and the file is considered "ready".

In the Internet mode of operation, the access computer 13/ is programmed to periodically poll the outgoing repository memory 35 to determine whether a message to be communicated has been stored, step 117. Upon recognizing that the message from telephone 17 has been stored in the repository memory, the access computer 13/ will compare the destination telephone number, 44-181-456-1234, with a host computer name look-up table and determine the Internet address of the access computer nearest to that of the destination telephone number, step 119. A drastically abridged version of such a table is shown in the table below:

Country Code	Area Code	Service Area Code	Name of Nearest Host Computer
01	408	526	sanjose.newnet.com
01	408	791	southbay.newnet.com
01	415	472	northbay.calnet.com
01	415	591	sfpenninsula.newnet.com
01	415	781	sanfran.calnet.com
01	510	323	eastbay.calnet.com
01	703	305	northvirgina.vanet.com
01	052	124	parma.co.it
44	173	928	uknet.co.uk
44	181	456	londonnet.co.uk
61	3	817	melbourn.co.au
81	03	3475	tokyonet.co.jp
886	035	732	taipei.co.tw

In the example being considered, the look-up table indicates that the Internet address of the nearest access computer is "londonnet.co.uk", which for the purpose of this example may be considered the access computer 13e. The access computer 13/ then preferably via Internet (step 121), transfers the message file to that computer, step 123, where it is stored in an incoming repository memory 37. This is typically performed by sending an e-mail message to the appropriate internet e-mail typically includes the voice message as an embedded attachment.

6

Access computer 13e, operating in its Internet mode, receives the e-mail message, step 125. In its telephone/fax mode, computer 13e is programmed to periodically poll its memory to determine if an incoming message file has been received, step 127. Once it has determined that such a message has been received, it detaches the destination telephone number from the file, step 129; prepares the number for dialing by eliminating all unnecessary country and area codes which are no longer necessary, step 13/ and dials the number of the desired telephone 19, step 133. The access computer determines if the telephone 19 is answered, step 135 and, if so, converts the message to analog format and sends it, step 137. If the telephone 19 is answered by a message recorder, the message is sent as voice mail.

When a fax message, rather than a voice message, is to be sent, the operation is only slightly different. When a user of a fax machine 21, located for instance in the United States in the "415" telephone area code and the "591" service area, desires to send a fax to a machine in Northern Virginia having a telephone number (703) 305-6789, he may proceed in a manner similar to that for a voice message. He may, by way of his fax telephone line, telephone an access computer 13k in his local telephone area and respond to the identification and destination address inquiries as set forth above with respect to voice mail messages. However, in response to the signal or statement asking the caller to speak the message or start the fax, the caller need merely to start his fax machine 21.

As with the voice message, the fax message is received by the computer 13k through its voice/fax board 33 and is converted to a digital format, creating an outgoing message file, step 113, including the destination fax phone number. The remainder of the fax transmission is identical to voice transmission, it being understood that when the fax is finally sent to the receiving fax machine 23, the access computer 13f is configured to determine that the answer inquiry in step 135 requires recognition of a fax machine.

In an alternative embodiment of the invention as shown in FIG. 4, a computer connected to the network only by a modem can be used as the sending and/or receiving access computer. The access computer 13m is not a server in that it does not have a dedicated Internet connection line. Rather, it is connected to the Internet 11 by means of a modem 39. With such an arrangement, a user of the fax machine 41 uses the same procedures as set forth above with respect to the embodiment of FIG. 1. If the fax is to be sent to a fax machine available to a receiving access computer which is a server, such as the access computer 13f, the overall operation will also be as described above in connection with FIGS. 1 and 3.

However, if the fax is to be sent to a fax machine 47 economically available only through a non-server receiving access computer, such as access computer 13n, a somewhat different procedure is required if the computer 13n is not connected to the Internet through its modem 45 when the fax is being sent. This different procedure requires the availability of an intermediary access computer which is a server.

Referring to FIGS. 3 and 5 together, the operation of a system in accordance with this embodiment of the invention may be understood. In FIG. 4, any of the access computers having a dedicated access to the telephone lines and gateways 15 of the Internet 11, such as the computer 13g, may serve as the intermediary access computer. When a user of fax machine 41 desires to send a fax to the fax machine 47, he proceeds as in the embodiment of FIG. 1 but placing his original telephone call to access computer 13m. The opera-

tion of the computer **13m** is identical to steps **101** through **123** of FIG. **3** (only steps **119** through **123** are shown in FIG. **5**). As shown in FIG. **5**, the computer **13m** is configured to query whether the transmission is completed, step **201**.

If the host computer **13n** is up and running, the computer **13m** can transmit the message as in the previous embodiment and an affirmative response to the "Transmitted?" query **201** causes the computer **13m** to end its operation on the fax, step **203**. However, if the receiving access computer **13n** is not up and running, the transmission will not be completed but will be transmitted to a server such as the access computer **13g**, acting as an intermediary access computer, step **225**.

The access computer **13g**, operating in its Internet mode of operation, senses the incoming file, step **227** and extracts the fax message and destination fax phone number, step **229**. The access computer **13g**, acting as an intermediary, is further configured to then operate much as sender access computer in that it determines the host computer name nearest to that of the destination fax telephone number, step **219** and attempts to connect and transmit to the receiving access computer **13n**, step **221**. If the connection and transmission are not successful, the access computer **13g** repeats the attempt. If the log on is successful, the message is transmitted, step **223**. Once the message is successfully received by the access computer **13n**, the remainder of the operation is identical to that described with respect to FIGS. **1** and **3**.

In an even broader scope, a single access computer having a dedicated access to the telephone lines and gateways **15** of the Internet could service the entire system. Moreover, a computer dedicated to the intermediary function and with no telephone/fax mode of operation could be employed to serve as the repository memory for the entire system.

A further embodiment provides a paging system **500** coupled to any of the above systems, as illustrated by FIG. **6**. This paging system is generally used by a caller to page a receiver using the present invention. This allows the caller to page a receiver to retrieve voice messages, fax messages, and the like that should be brought to the attention of the receiver in an efficient manner. Other benefits of the paging system will be better understood by way of the following descriptions.

As previously described, the system includes computers **11** on the Internet **11**. The Internet includes representative computers **13a** through **13l** interconnected with each other, as well as with many other computers not shown, by means of the usual telephone lines and gateways **15**. Each of the computers **13a** through **13l** serve as an access point in the system of the invention.

In addition to the access point computers **13a** through **13l**, there are shown representative telephone sets **17** and **19** and fax machines **21** and **23**. The telephone **17** may be selectively coupled through its own central office **25**, and possibly others, to various telephone units throughout the world. Similarly, the telephone **19** and faxes **21** and **23** may be selectively coupled through their respective central stations **27**, **29** and **31** to other telephone units.

So that all of the access computers **13a** through **13l** are capable of communicating not only on the telephone/fax line but also on the Internet line, they should each usually include a modem. So that computers **13l**, **13k**, **13e**, **13f**, for example, can communicate with telephones **17**, **19**, and fax **21**, **23**, they should each include a voice/fax board **33**. The voice/fax board can be a single unit or multiple units, depending upon the application.

Each of the access point computers **13a** through **13l** also includes two types of control, one for telephone/fax communication and one for Internet communication. Such controls are often software controllable, but can be hardware controllable too. Furthermore, each of the access computers **13a** through **13l** should be capable of performing the functions of a host computer; that is, it should be capable of transmitting and receiving data from and to other access computers by using a communication protocol. In order for the system to operate efficiently, at least one access computer must be a server in the sense that it has a dedicated Internet connection. Alternatively, no server is necessary so long as both the sending and receiving access computers and their modems are up and running at the time of transmission.

These access point computers **13a** through **13l** are each also coupled to a paging system. The paging system can be any suitable system capable of being coupled to any of the above access computers in any of the above service areas. As an example, the paging system includes both local and wide area paging networks **503**.

Local area networks generally provide paging services using one or more transmitters operating on a single or multiple frequencies, which cover all or a portion of a metropolitan area. Wide area networks encompass several overlapping areas of a large metropolitan area or a number of non-overlapping metropolitan areas. Paging occurs by using a variety of local transmitters, and broadcasting the paging message from all transmitters to an intended receiver who may be anywhere within the wide area network. Preferably, the paging system includes features of both local and wide area networks or the like. This paging system allows a receiver to receive pages or messages within the service area or outside the service area in an efficient manner.

The paging system **500** includes a plurality of paging units **501** or the like. Each of these paging units **501** is attached to or held by the receiver. An example of a paging unit is from Pacific Bell, which is a product manufactured by Motorola. Of course, other paging units can be used depending upon the application.

Referring to FIGS. **6**, **7**, and **8**, aspects of operating the paging system according to the present invention are described. Of course, these operating aspects are merely examples and should not limit the scope of the claims herein. One of ordinary skill in the art would recognize other variations, modifications, and alternatives.

In an embodiment, the system uses a calling procedure for paging a receiver as illustrated by the simplified flow diagram **600** of FIG. **7**. The caller (step **603**) first places a voice message from a receiver into the system by way of any of the embodiments described herein. For instance, the caller makes a local call to a local access computer and provides a voice message or facsimile message for the receiver. Any of the above techniques among others can be used.

Rather than allowing the receiver to select the time for accessing the voice message without any notification from the caller, the caller pages the receiver by way of this embodiment to notify the receiver of the voice or facsimile message. For instance, the caller picks up a conventional telephone **505** and dials a phone number **605** which access a paging system **607**. The phone number corresponds to the paging unit held by the receiver.

After accessing the paging system, the caller enters a code **609** using the telephone keypad in the form of a numeric or alphanumeric message to complete the paging process from the caller side. The receiver receives the page (step **611**) and

the code from the caller (step 613). Based upon the code from the caller, the receiver is now notified that a voice message or facsimile message waits in the receiver's voice mail or facsimile machine. The receiver calls using a conventional phone the voice mail or facsimile machine to check for the caller's message (step 617). The operation then returns (step 619) to step 603.

An alternative embodiment 700 allows the caller to place the voice message and the page into the access computer during a single phone connection, as illustrated by FIG. 8. The caller (step 701) calls (step 703) via telephone 507 to a local access computer 13*m*, for example, without paying for long distance services by the telephone company or the like. The caller waits for the proper prompt on the telephone from the access computer and then accesses the access computer by entering his/her identification number 705. Upon receiving the proper prompt from the access computer, the caller enters a pager phone number 707 for the receiver. A further prompt from the access computer indicates that a voice mail message is ready to be transmitted by the caller. The caller provides the voice mail message into the access computer by speaking into the telephone (step 709). Details of providing and converting the voice mail message were described in the preceding embodiments. The voice mail message and pager phone number are converted into a digital format for transmission over the Internet 711 to the receiver's voice mail destination.

At this destination at another access computer, the pager number for the receiver is dialed (step 713) using the access computer. The access computer connects to the paging system. Once connected, the caller code is transmitted to the paging system (step 715) from the access computer. The receiver is paged (step 717) by the paging system. The receiver receives the page and the code from the caller on a display (step 719) on the paging unit, thereby notifying the receiver of the receiver voice mail message or facsimile message. The caller calls (step 721) via telephone to an access computer having the voice message by the caller. The receiver retrieves the voice message (step 725) deposited by the caller. Details of this operation were described above and are further described below.

These descriptions for sending voice messages and paging are merely examples of the types of functions that can be performed on the present system for telecommunications. Various modifications, alternatives, and variations can also be used. Accordingly, the above descriptions should not limit the scope of the claims herein.

System Software

An embodiment any of the above systems can be implemented on a computer or computers using processing functions which are carried out using computer software. This software is programmed into a memory of one of the computers or more than one computer or other portions of the system. The software can be programmed using a suitable code such as C, C++, and others.

The software is merely an example of a medium used for implementing embodiments of the present invention. The software can be combined or separated using software features and hardware. Additionally, features in the software can also be implemented using objects or the like. Of course, one of ordinary skill in the art would recognize other modifications, alternatives, and variations. Details of the software are described by way of the Figures below.

FIGS. 9-12 are simplified illustrations of methods or processes implemented using computer software and system hardware. Of course, other processes or methods can be used depending upon the application.

The simplified flow diagram 800 of FIG. 9 illustrates a process leaving a message with a receiver according to an embodiment of the present invention. The process generally involves steps of destination number entry 803, message recording 815, information attachment 823, searching destination server address 825, transmitting the message file 827 over the Internet 829, and others.

A destination telephone number from the caller side or caller (step 801) can be entered (step 803) using these following steps according to the present invention. If a pager for the receiver is used (step 805), the process allows the caller to enter a pager telephone number for the pager of the receiver through a telephone followed by a key assigned for allowing entry of the caller code for the pager (e.g., "**"), which allows the caller to enter a number (i.e., caller code) to be appeared on the pager display or screen. The caller then enters a destination telephone number (step 811) using the telephone keypad.

Alternatively, if a destination telephone number with an extension of the receiver (step 809) is used, the process allows the caller to enter the destination number with the extension (step 811) for the receiver through the telephone keypad. In particular, the caller enters the destination number into the access computer via telephone followed by a key (e.g., "**" on the telephone assigned for prompting entry of the extension number, which allows the caller to enter the extension number into the access computer. Alternatively, the caller merely enters the destination telephone number (step 803) for the receiver on the telephone keypad.

After entering the destination telephone number (and pager number in some embodiments), the process allows the caller to record a voice message (step 815) to be sent to a voice mailbox in memory of the access computer or other location. Alternatively, the process allows the caller to record a message which will be sent via facsimile to the receiver. Details of recording the voice message are described throughout the specification.

If the caller wants to re-record (step 817) the message, a key (e.g., "1") assigned to this function is depressed (step 819) on the telephone, which allows the caller to re-record the message (step 815) via branch 816. Alternatively, the caller presses a key assigned for termination (step 821) of the voice message. Upon terminating the voice message, the phone is placed back on the hook, which also can terminate the message in this process.

The voice message (or facsimile message) and destination (and pager number in some embodiments) are placed into memory of the access computer. The process attaches (step 823) sender/receiver information (e.g., e-mail address, phone number) to the message file. It searches (step 825) a destination server address, which is closest to the destination number. Preferably, the destination server address is in the same calling code (or area code) as the destination number to reduce any costs associated with conventional long distance calling, which is a benefit of the present invention. This occurs by matching the destination address to the destination server address in a look-up table or the like. Details of this procedure were previously described.

The message file with sender/receiver information (step 827) is transmitted to the destination server (or access computer) for storage (or retrieval) purposes. Any of the above embodiments and others can be used for preparing the sender/receiver information and message file and transmitting them over the Internet (step 829) to a destination access computer. The destination access computer can dial the destination telephone number and forward the voice message to a voice mail box, facsimile machine, or the like.

The above descriptions of the caller side process are merely examples of functions performed by computer software and the like. As is known to one of ordinary skill in the art, the above functions could be combined or even separated using either or both hardware and software or the like.

FIG. 10 is a simplified flow diagram of a process 900 performed on the receiver side (step 901) according to the present invention. The process begins by performing steps for receiving a message file (step 903), which includes at least the voice message, the destination number, and in some embodiments the pager number and caller code. If the message file is received from the Internet (step 905), a copy of the message file is placed into a working repository (step 907). Alternatively, the process waits in a loop (step 909) to receive the message file via branch 908.

Upon receiving the message file, which is kept in a working repository, the process detaches (step 911) the voice message from the sender/receiver information. The sender/receiver information is read by the process (step 913). This reading step allows the process to designate the destination number and paging instructions, if any. The process stores (step 915) the message file into a memory of the access computer. In an embodiment, the process copies (step 917) the message file to a voice mailbox in the access computer or system from the working repository.

The process via read destination number step dials the destination number (step 919). Depending upon the type of delivery designated, the process performs the following steps. If the sender/receiver information designates a pager number (step 921) for the receiver, the process via access computer dials and calls (step 923) the pager number and, after the appropriate prompt, enters the number to be appeared on the pager display, as often necessary by the paging system. The process then dials the destination number (step 929) to connect the access computer to the device (e.g., voice mailbox, facsimile, etc.) at the destination number to deliver the message.

Alternatively, if the voice message is to be delivered at the receiver's destination phone number extension (step 925), the process via access computer dials (step 929) the destination number and, after receiving the appropriate prompts after a successful connection, enters the extension number of the receiver (step 927). Alternatively, the process via access computer merely dials the destination number (step 929) before proceeding to the remaining steps. These remaining steps can include transferring the voice message to a voice mailbox, a facsimile machine, or the like, such as those shown in the embodiments herein.

Upon successful connection, the access computer plays (step 931) the voice message. The voice message can be played directly to the receiver, to a voice mailbox, or to a facsimile machine. If the message is needed to be repeated by the receiver (step 933), the receiver presses (step 935) a key assigned (e.g., "1") for such a repeat operation or the receiver hangs up (step 937) the phone to terminate the operation.

The above descriptions of a receiver side process are merely examples of functions performed by computer software and the like. As is known to one of ordinary skill in the art, the above functions could be combined or separated using either or both hardware and software or the like.

FIG. 11 is a simplified flow diagram 1000 illustrating a process for users (or receivers) of the present system to retrieve messages from an access computer, rather than a personal facsimile machine or voice mailbox. The process begins at step 1001. The user dials a telephone to call (step 1003) the local access computer. Upon connection and

receiving a selected prompt asking the user for an access code, the user enters the access code (step 1005) through the keys of the telephone, which is received by the process. The user is now logged on.

The process prompts to the user a variety of options that could be performed by the present system. In an embodiment, the user selects a voice mailbox (step 1007), which can be password protected (step 1009) for the user. In these embodiments, the user enters a password. The process checks the password for verification or validation. Once verification or validation is made, the user selects a prompt for listening (step 1011) to voice messages, if they have been left.

Depending upon the type of delivery attached to the message, the user can select any one of a variety of messages. For instance, the user can select messages left using solely the destination number. Alternatively, messages prompted by a pager (step 1013) can be selected. Of course, the type of message selected depends upon whether any one is available.

The process for retrieving messages in the preceding description is merely an example of numerous functions performed by computer software and the like. As is known to one of ordinary skill in the art, the above functions could be combined or separated using either or both hardware and software or the like.

FIG. 12 is a simplified flow diagram 1100 of a process for delivery notification to a receiver. The process begins at step 1103. When a message file is transmitted to the receiver side of the access computer, the receiver can check for notification of messages from a caller using a variety of techniques. These techniques include notification by way of e-mail, facsimile, or phone mail. If the receiver would like notification from a personal e-mail box (step 1105), the caller must specify or set the e-mail notification to the voice message on the present system. The caller can also specify a notification to the receiver's facsimile, voice mailbox, or the like.

Alternatively, the receiver can ask for notification by forwarding all messages from callers to an e-mail box (step 1107) or a voice mailbox (step 1111) or facsimile machine (step 1109). The receiver can also change the designation of the notification by simply calling the access computer and providing the designation.

In other embodiments, the process notifies to the receiver the arrival of e-mail messages to a receiver by way of transmitting the notification to the receiver's voice mailbox, facsimile machine, or e-mail box. Voice messages can also be transmitted to an e-mail box or voice mailbox or facsimile machine using the appropriate conversions. Of course, the type of delivery notification will depend upon the application.

While the present invention has been described with reference to a few specific embodiments, the description is illustrative of the invention and is not to be construed as limiting the invention. Various modifications may occur to those skilled in the art without departing from the true spirit and scope of the invention as defined by the appended claims. For instance, each access computer may actually comprise two separate computers, one for incoming messages and the other for outgoing messages. In such a case each individual computer need only be configured for its specific function.

In the claims:

1. A method for telecommunication, said method comprising:

transmitting a message and paging data from a first telephone device located in a first service area through

13

a telecommunication medium, said paging data comprising a destination telephone number;

receiving at said first service area said message and said paging data in a first access device, said first access device being my computer capable of coupling to a network;

converting said message into a first digital signal in said first access device;

converting said paging data into a second digital signal in said first access device;

comparing said destination telephone number with a look-up table to determine a network address of a second access device, said second access device being any computer capable of coupling in to a network;

transmitting said first digital signal and the second digital signal over a network of interconnected computers to said second access device at a second service area;

converting said first digital signal into data for storage into a memory at said second access device;

converting said second digital signal into telephone key codes at said second access device and dialing a paging unit at a receiver location using a paging systems, said paging unit being able to receive pages or messages, said paging system comprising both local and wide area paging networks; and

retrieving said data from said memory at said second service area using a second telephone device.

2. The method of claim 1 wherein said telecommunication medium is a telephone line.

3. A computer program product for a computer system coupled to a network, for paging a user when an incoming message is received, the computer program product comprising:

- a computer readable memory comprising;
- code that retrieves the incoming message from the network;
- code that directs a processor coupled to said memory to determine a pager number in response to the incoming message;
- code that directs the processor to contact a paging system in response to the pager number;
- code that directs the processor to transmit a paging message to the paging system;

14

code that directs the memory to store an outgoing message, the outgoing message including an outgoing pager number and a paging message; and

code that directs the processor to transmit the outgoing message from the memory to the network;

wherein the computer readable memory further comprises a database including the particular pager number for the user.

4. The computer program product of claim 3 wherein the incoming message further comprises an incoming E-mail message.

5. The computer program product of claim 3 wherein the incoming message further comprises an incoming voice message.

6. The computer program product of claim 3 wherein the incoming message further comprises an incoming facsimile message.

7. The computer program product of claim 3 wherein the outgoing message further comprises an E-mail message.

8. The computer program product of claim 3 wherein the outgoing message further comprises a voice message.

9. The computer program product of claim 3 wherein the outgoing message further comprises a facsimile message.

10. The computer program product of claim 3 wherein the outgoing message is an incoming message for another user.

11. The method of claim 1 wherein the message comprises an e-mail message.

12. The method of claim 1 wherein the data comprise a voice message.

13. The method of claim 1 wherein the data comprise an e-mail including a voice message.

14. The method of claim 1 wherein the data comprise a facsimile.

15. The method of claim 4 wherein the data comprise a paging message.

16. The computer program product of claim 3 wherein the outgoing message comprises an E-mail including a voice message.

17. The computer program product of claim 3 wherein the outgoing message comprises an E-mail message.

18. The computer program product of claim 3 wherein the outgoing message comprises a voice message.

19. The computer program product of claim 3 wherein the outgoing message comprises a facsimile message.

* * * * *