

19



LE GOUVERNEMENT
DU GRAND-DUCHÉ DE LUXEMBOURG
Ministère de l'Économie

11

N° de publication :

LU101005

12

DEMANDE DE BREVET D'INVENTION**A1**

21

N° de dépôt: LU101005

51

Int. Cl.:
F16L 17/00, F16L 37/00

22

Date de dépôt: 20/03/2018

30

Priorité:
21/03/2017 IN IN201711009888

72

Inventeur(s):
SHRIVASTAVA Anurag – Gurgaon Haryana (Inde),
RAJASEKARAN V. – Gujarat 370415 (Inde), BOSE
Partha – Gujarat 370415 (Inde), SUBRAMONIAN K. –
Gujarat 370415 (Inde)

43

Date de mise à disposition du public: 26/03/2019

73

Titulaire(s):
JINDAL SAW LTD – New Delhi 110066 (Inde)

74

Mandataire(s):
Patent42 SA – 4081 Esch-sur-Alzette (Luxembourg)

54

Positive Lock system for Restrained Joints of Ductile Iron Spun Pipes and Fittings.

57

ABSTRACT: This present invention relates to novel positive lock system for restrained joints of ductile iron spun pipes and fittings which are able to take all the thrust loads produced due to transmitting fluids pressure and provide certain angular deflections to the axis of two pipes. For ductile iron pipe to be joined, a socket (bell shape) and a spigot (plain end) sections are provided in pipes. For joining plain end is inserted in bell shape end. As the water pressure surges, the joint tends to disengage due to increasing axial loads. To take these axial loads, a circumferential chamber is provided in bell shape end and plain end is provided with a weld bead of suitable size. Axial forces generated due to water pressure is transmitted to pipe socket through welding via locking segments. Locking segments are inserted in circumferential chamber and they stays between chamber and welding bead. Circumferential chamber has suitable clearances to provide the required angular deviations at the joint. Figure 3 LU101005

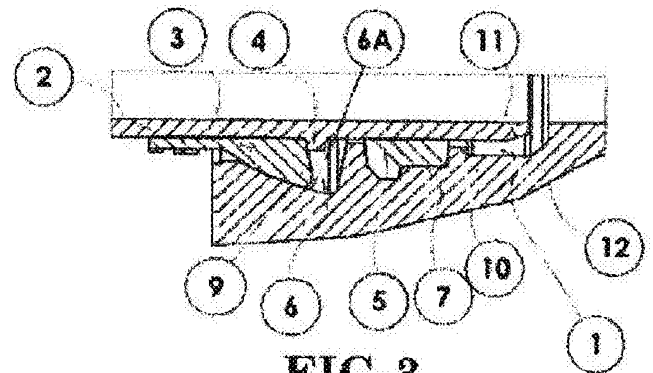
**FIG-3**

Title: Positive Lock system for Restrained Joints of Ductile Iron Spun Pipes and Fittings**Description****Field of the invention:**

The present invention relates to positive lock jointing system for ductile iron spun pipe and fittings. More particularly the invention relates to positive lock system for restrained joints of ductile iron spun pipes and fittings and its assembling process thereof.

Background of the invention:

Ductile iron spun pipes are being used for distribution of drinking and sewerage water since late 1950s. This type of pipe is a direct development of earlier cast iron pipe because of its better structural properties and various other features.

Ductile iron pipes are manufactured by centrifugal casting of molten metal. Several types of rubber-gasket joints are available with ductile-iron pipe and fittings to accommodate a wide variety of applications. In addition to the flanged joints following two type of joints are possible:

- a. Push-on joint,
- b. Restrained Joints

Most widely used joint is normal-push-on joint. Ductile iron pipes comprise of socket and spigot ends. The inside surface of the socket has grooves to hold the rubber gasket. The gasket has a hard part called the 'heel' which gets engaged in the groove of the socket to firmly hold the gasket. The other part of the gasket is the bulb portion which is comparatively softer than the heel portion of the gasket. Both softer bulb and the harder heel portions of the gaskets are vulcanized to form a circular single part. The spigot of the next pipe will have a taper portion to facilitate smooth insertion of the spigot end in to the socket of the pipes. The spigot is inserted into the socket holding the rubber gasket. The spigot exerts uniform circumferential pressure over the soft portion of the rubber gasket and the pipe is pushed in to the socket until one line of the insertion mark gets into the socket and the other insertion mark is visible.

The internal hydrostatic pressure acts perpendicularly on any plane with a force equal to the pressure times the area of the plane. All components of these forces acting radially within a pipe are balanced by circumferential tension in the wall of the pipe. Axial components acting on a plane perpendicular to the pipe through a straight section of the pipe are balanced internally by the force acting on each side of the plane.

However, in the case of a bend, the forces acting axially along each leg of the bend are not balanced. The vector sum of these forces is the thrust force. To prevent separation of the joints, a reaction equal to and in the opposite direction of thrust force must be established.

Conventional ductile iron pipe joints are push-on type joints. These joints do not offer any significant resistance to joint separation.

The unbalanced thrust forces are generated in following conditions:-

- Change in directions
- Thrust at Bends – Horizontal/Vertical
- Thrust at a Tee or Wye
- Thrust at a Reducer
- Thrust at a Dead End or Valve.

There are two ways to take care the unbalancing above thrust load:

- a) Using thrust block/ concrete block;
- b) Using restrained pipe.

Thrust Block is one of the most common methods of providing resistance to thrust forces is the use of thrust blocks. Resistance is provided by transferring the thrust force to the soil through the larger bearing area of the block such that the resultant pressure against the soil does not exceed the bearing strength of the soil. Design of thrust blocks consists of determining the appropriate bearing area of the block for a particular set of conditions.

An alternative method of providing thrust restraint is the use of restrained joints. A restrained joint is a special type of push-on joint that is designed to provide longitudinal restraint.

Restrained-joint systems function in a manner similar to thrust blocks, insofar as the reaction of the entire restrained unit of piping with the soil balances the thrust forces.

Thus, alternate to above concrete thrust block concepts is to use restrained pipe solutions like mechanical bolted restrained joint with gland and tensioning ring, K-type joint etc. However, the existing restrained joints are having limitations in terms of ease and speed of assembly, requirement of huge number of components, pressure rating of the joint.

Therefore, there is need of technically advanced restrained jointing system in ductile iron pipe jointing which can decrease the assembly timing and difficulties as well widen the scope of ductile iron pipe applications areas.

Object of the invention

In order to obviate the drawbacks of the prior art, the present invention aims to provide lock jointing system for ductile iron spun pipe and fittings.

Further object of the present invention is to provide a positive lock system for restrained joints of ductile iron spun pipes and fittings.

Further object of the present invention is to provide a positive lock system for restrained joints of ductile iron spun pipes and fittings, which are easy to assemble and can be used in restrained conditions.

Further object of the present invention is to a process of assembling positive lock system for restrained joints of ductile iron spun pipes and fittings.

Summary of the Invention:

In order to obviate the drawbacks of the prior art and achieve the afore-said objectives the present invention a novel positive lock system for restrained joints of ductile iron spun pipes. The positive locked joint between two ductile iron pipes is obtained by inserting the plain end of one pipe into the bell end of the other pipe. Positive locking is obtained by inserting series of lock segments in between the weld bead available on plain end and circumferential chamber of the bell socket of other pipe. The joint comprises of a

- a. Bell shape socket 1 of a pipe made of ductile iron,
- b. Plain end 2 of another pipe made of ductile iron,
- c. Radially compressed elastomer gasket 5 inserted between the outer peripheries of plain end and inner peripheries 7 of socket 1
- d. Weld bead 4 which is made on plain end of pipe at suitable location and
- e. Series of lock segments 3, inserted through the cutout window 8 and rotated in between the weld bead and circumferentially protruded downwards chamber 6.

The new pipe is having one additional chamber to conventional ductile iron pipe socket. This chamber acts as 'locking chamber'. A weld bead is made on the spigot of the pipe. In assembly the total thrust load produced in the pipe line is transferred to the locking chamber of the socket from weld bead through specially designed ductile iron lock segments. The chamber is designed in such a way as to absorb all the axial loads generated by the internal pressure or the pulling forces, therefore the desired angular deflections can be achieved. In this manner all the thrust load are converted to axial load which is shared by series of pipes along the subject joint and finally transferred to its surrounding external soil/earth by its bearing resistance.

The complete assembly form the self-restraining joint, thus eliminating the need for thrust blocks. Apart from above the invention permits the use of such pipe joints in trenchless method of pipeline laying by horizontal drilling of bore and pulling of pipelines due to its capacity to sustain very high traction forces. These invented Ductile iron pipes with a positive lock jointing system are quick to assemble and well suited to be used in seismic zones, fault crossings, liquefaction zones, and connections to structures, floating pipelines, across river sea or water bodies, laying on steep slopes, mine dewatering and tailings pipelines without thrust blocks or external restraining requirements, snow making application.

The positive locking system can be prepared in various size ranges from DN100 to DN1800 as per EN545/ISO10804-1 with a suitable range of fittings. However, the construction of the socket locking chamber varies as per size with respect to pressure rating design traction forces.

The new positive locking system has widened the scope for ductile iron pipe application thus proved to be an advanced restrained jointing system.

Detailed description of the drawings:

The foregoing and further objects, features and advantages of the present subject matter will become apparent from the following description of exemplary embodiments with reference to the accompanying drawings, wherein like numerals are used to represent like elements.

It is to be noted, however, that the appended drawings illustrate only typical embodiments of the present subject matter, and are therefore, not to be considered for limiting of its scope, for the subject matter may admit to other equally effective embodiments.

For a fuller understanding of the nature and object of the present invention, reference is made to the accompanying drawings, wherein:

Figure 1 illustrates longitudinal section of the joint on axis A-A in accordance with an embodiment of the present invention.

Figure 2 illustrates front face view of the assembly in accordance with an embodiment of the present invention.

Figure 3 illustrates detailed view of the assembly parts in aligned position of both pipes in accordance with an embodiment of the present invention.

Figure 4 illustrates side view of lock segment showing protruded block for locking in accordance with an embodiment of the present invention.

Figure 5 illustrates front face of the lock segment in accordance with an embodiment of the present invention.

Figure 6 illustrates isometric view of Lock segment in accordance with an embodiment of the present invention.

Detailed description of the invention:

The following presents a detailed description of various embodiments of the present invention with reference to the accompanying drawings.

The embodiments of the present invention are described in detail with reference to the accompanying drawings. However, the present invention is not limited to these embodiments which are only provided to explain more clearly the present subject matter to a person skilled in the art of the present disclosure. In the accompanying drawings, like reference numerals are used to indicate like components.

The specification may refer to "an," "one," "different" or "some" embodiment(s) in several locations. This does not necessarily imply that each such reference is to the same embodiment(s), or that the feature only applies to a single embodiment. Single features of different embodiments may also be combined to provide other embodiments.

As used herein, the singular forms "a," "an" and "the" are intended to include the plural forms as well, unless expressly stated otherwise. It will be further understood that the terms "includes", "comprises", "including" and/or "comprising" when used in this specification, specify the presence of stated features, integers, steps, operations, elements, and/or components, but do not preclude the presence or addition of one or more other features, integers, steps, operations, elements, components, and/or groups thereof. It will be understood that when an element is referred to as being "attached" or "connected" or "coupled" or "mounted" to another element, it can be directly attached or connected or coupled to the other element or intervening elements may be present. As used herein, the term "and/or" includes any and all combinations and arrangements of one or more of the associated listed items.

The figures depict a simplified structure only showing some elements and functional entities, all being logical units whose implementation may differ from what is shown.

Unless otherwise defined, all terms (including technical and scientific terms) used herein have the same meaning as commonly understood by one of ordinary skill in the art to which this disclosure pertains. It will be further understood that terms, such as those defined in commonly used dictionaries, should be interpreted as having a meaning that is consistent with their

meaning in the context of the relevant art and will not be interpreted in an idealized or overly formal sense unless expressly so defined herein.

The present invention described herein relates to a restrained semi flexible joint for ductile iron pipes. It is a self-restrained, semi-flexible jointing system of socket and spigot pipe. The joint can be deflected up to the designed angle as a function of the size range. Water or other fluids passing through the pipeline exert an internal pressure on the walls of the pipe barrel and the same force is transferred to the adjacent pipe. Said locking system helps in transferring the thrust forces generated to the next pipe through a welded bead shaped on the spigot of each pipe via lock segments. The complete jointing assembly forms the self-restraining joint, thus eliminating the need for thrust blocks, and facilitates trenchless laying of ductile iron pipelines. Ductile iron pipes with the present jointing system are quick to assemble and well suited to be used in seismic zones, fault crossings, liquefaction zones, and connections to structures, floating pipelines, hydro power plants, laying on steep slopes, firefighting water mains, and mine dewatering pipelines without thrust blocks or external restraining requirements.

According to an embodiment of the present invention, locking is achieved between the pipe socket and the weld bead, made on the other pipe spigot, with the help of specially manufactured locks. The chamber is designed in such a way as to absorb all the axial loads generated by the internal pressure or the pulling forces, therefore the desired angular deflections can be achieved.

According to an embodiment of the present invention, the ductile iron pipes are designed in such a way that individual pipes are connected using the lock system to form one complete system without need of welding, screwing, testing, surface treatment or without having problem of loosening.

According to conventional design, the ductile iron pipes are supplied to suit and facilitate restrained jointing in which the axial Movement of the pipe is arrested by mechanical means. The ductile iron pipes with these joints are ideally suitable for the pipe line to be laid over loose soil or marshy land where one cannot provide anchor blocks at Tee points, or bends etc. This joint comprises an assembly two pipes of socket and spigot type with glands, split ring, and a

set of hook bolts, nuts, and washers. The spigot end of the pipe is to be provided with a weld bead. The socket of the pipe to be joined will have a circumferential projected collar.

In accordance with an embodiment, present invention relates to novel positive lock system for restrained joints of ductile iron pipes and ductile iron fittings which are able to take all the thrust loads produced due to transmitting fluids pressure and provide certain angular deflections to the axis of two pipes. Each ductile iron pipe suitable for this type of joint is provided with a bell shape socket 1 and a plain ended spigot 2. Normally plain ended spigot 2 is pushed in pipe socket 1 to do the jointing of two pipes. An elastomeric/rubber gasket 5 is placed in a gasket chamber 7 provided in bell socket 1. The inner diameter of the gasket 5 is less than the plain end 2 outer diameter. So during assembly the plain end 2 of a pipe compresses the gasket 5 radially to make the joint water tight. For the positive locking joint a weld bead 4 is made on the circumferential periphery of the plain end 2 of the pipe. A series of lock segments 3 are inserted in the circumferential chamber 6. The lock segments 3 are always staying between the weld bead 4 and the circumferential chamber 6 inner surface 9. The lock segment 3 is designed in such a way that it has a front face 15 at a suitable angle to dissipate all the axial forces in required direction and a rear circular face 14 so that it can match to the socket chamber face 9 to have smooth sliding during axial angular deflection at the joint. The radius and center of the circumferential face 9 and 14 is calculated so that the maximum axial forces can be transferred to pipe socket 1 at the required angular deflection of two axis. As per invention the thrust loads generated due to transmitting fluid pressure should be transferred from weld bead 4 to the lock segment 3 and from lock segment 3 to the circumferential chamber 6 of the socket 1.

In accordance with another embodiment, the positive locked joint between two ductile iron pipes as shown in FIG-1 is similar to the type of joint explained in US3684320 and other referred patent are EP1460325A2, US6062611, US28883899, US7806445B2 except the structure of the lock segment 3, center and radius of the circular face 14 of lock segment and 9 of pipe socket 1.

In accordance with another embodiment, as shown in FIG-3, the joint comprises of a bell shape socket 1 of a pipe, a plain end 2 of another pipe, radially compressed elastomer gasket 5 between the outer peripheries of plain end 2 and inner peripheries of socket 1, a weld bead 4 which is made on plain end 2 of pipe at suitable location and series of lock segments 3 inserted

through the cutout window **8** shown in FIG-2 and rotated in between the weld bead **4** and circumferentially protruded downwards chamber **6**. Lock segment **3** always remain on the outer periphery of the plain end **2** of the pipe. The radius of the face **16** in FIG-5 of lock segment **3** should be equal or under required limits to the outer radius of the plain end **2** periphery. Both the plain end **2** and bell shape socket **1** are made of ductile iron. The lock segment **3** are casted from ductile iron as well. The joint is water sealed with the help of elastomer gasket **5** by its compressible property. The inner diameter of the gasket **5** is less than the outer diameter of the plain end **2** of the pipe to be inserted in the gasket **5**. So after insertion the gasket **5** got compressed between the plain end **2** of one pipe and the gasket chamber **7** of the socket **2** of other pipe.

During water or other fluid transmission the pressure inside the pipe body increases. It leads to generation of circumferential loads and axial loads. Circumferential loads are taken care by the pipe body itself. Due to axial loads the joint tends to dismantle itself. The axial load produced due to water pressure transmits to the plain end **2** of the pipe. In positive locking joint the axial load from plain end **2** is perceptible in weld bead **4** as it is bonded to the former. This axial load produced is transmitted to the lock segment **3** from weld bead **4** as both have a face contact with each other. The face **15** in FIG-4 of the lock segment **3** is in contact with the weld bead **4**. The inclination the lock segment **3** face **15** is designed in such a way the axial load can be transmitter in required direction towards rear circular face **14** of the lock segment **3**. Axial load transmitted to lock segment **3** from weld bead **4** is then transmitted to the socket **1** of the pipe. This load is transmitted through rear face **14** of the lock segment **3** to radial face **9** of circumferential chamber **6** socket **1**. Socket **1** of pipe is to be designed in such a way that it should be able to take all the axial force transmitted to it whether it is due to working pressure of transported fluid, loads due to surge etc.

Both the face **14** and **9** should have same radii for better match and smooth sliding during the joint axial deflection and load transmission at the same time. The clearance is provided between front face **15** of the lock segment and chamber **6** starting position to facilitate the angular deflection of the joint. The width of the face **14** of the lock segment **3** is calculated to have maximum contact during the highest angular deflection of the joint so that maximum axial loads can be transmitted. The height of the protruded block and face **14** of lock segment **3** is calculated so that it may be sufficient to transmit the loads in required direction and minimum

magnitude. A proper combination of height and width of the face **14** results to optimize the axial loads transmission to the pipe socket **1** and reactions of these loads to plain end **2** of the pipe so that pipe can be produced with optimum body thickness.

Chamber **12** is provided to have clearance of the plain end **2** of pipe and chamber **11** with the socket **1** inner wall.

Ring **10** will act like a mechanical stopper to the higher angular deflections than recommended.

According to another embodiment of the invention, a series of lock segments **3** as a part of joint always remain on the outer periphery of the plain end **2** of the pipe with the help of tying belt **18**. The radius of the bottom face **16** of the lock segment **3** is kept equal or under required limits to the outer radius of the plain end periphery. Lock segments **3** are provided with end stoppers **17** (FIG-6) projected outwards to give housing for tying belt and help in lock rotation during assembly. Lock segments **3** are provided with rear spherical face **14** with highest sphere diameter to get maximum tangential angle. Highest spherical diameter of the rear spherical face **14** of lock segment **3** as part of the joint assembly leads to higher axial load absorption capacity of socket. Lock segments are provided with front face **15** which is at some inclination with the horizontal to direct the axial loads in required direction.

Socket is having clearance **6A** between the lock face **15** and chamber **6** end face to give enough room for the lock segment during angular deflection of the joint. Each lock segment is a sector of certain angle in circular ring with protruded projection designed in such a way that uniform load distribution achieved on socket circumferential chamber **6** and can be rotated freely during assembly.

Bell shape socket **1** is provided with ring **10**, which work as mechanical stopper to limit the angular deflection at maximum allowed and work as a design safety feature at higher fluid pressures. The diameters are selected as such to achieve the maximum allowable angular deflection in any case.

In accordance with another embodiment, the present invention provides procedure for assembly installation of the positive lock system for restrained joints of ductile iron spun pipes and fittings. Said procedure involving following steps:

1. **Socket preparation:** Keeping the lock insertion chamber on the top side to facilitate the easy insertion of locks. Cleaning the socket internal grooves such as gasket seating groove, lock retaining chamber, etc. Removing all the dust and foreign particles. Fixing the gasket by lubricating the gasket groove with suitable lubricant. For this purpose, carefully wipe a thin film of lubricant supplied with the pipes by the manufacturer over the sealing groove surface. A loop is made in the gasket and said gasket is fixed into the socket so that the hard-rubber claw on the outside engages in the retaining groove in the socket. The lower part is first inserted in the retaining chamber of the gasket groove and then unlooping the heart shaper part to fix it into the gasket seating groove. Ram the gasket softly to fix the gasket in groove properly. Once the gasket is proper seated, a thin layer of lubricant is applied on the top face of the gasket.

2. **Preparation of spigot:** Cleaning the surface of spigot end with soft wire brush/ paint brush. Putting thin layer of lubricant on the spigot end of the pipe with weld bead particularly at the chamfer / bevel area just before assembly.

3. **Assembly of the joint:** once the spigot is ready, it seated in the socket. The pipes must not be at an angular deflection when being pulled in and till the lock segments are being fitted. Inserting the lock segments one by one through the window provided in the socket face and distributing them along the circumference of the pipe, working alternately left and right. Then moving all the segments round in one direction until the last segment can be inserted through the openings in the end-face of the socket and can be moved to a position where it provides secure locking. Only a small part of the humps on the last locking segment should be visible through the opening in the end-face of the socket. Should any segments jam, they should be moved to their intended position by gentle taps with a hammer by moving the pipe as it hangs on the sling.

4. **Locking:** all the lock segments are pulled back in the outward direction until they are in contact and pressed against the slope of the retaining chamber. Cable ties / nylon strap are clamped around outside periphery of lock segments as shown in the image and

tightened sufficiently far enough to still allow the lock segments to be moved. Lock segments are lined up such that they are resting against the barrel of the pipe over their full circumference area without overlapping. One end of pipe is pulled (axially) towards the side under laying such that weld bead comes into contact with all lock segments. Ensuring that all lock segments are in line uniformly and tighten the clamping strap until the lock segments are bearing firmly against the pipe around the whole of its circumference. Now, further movement of the locking segments should not be possible. When the pipe is in an un-deflected state, all the lock segments should be approximately same longitudinal distance away from the socket face. Once the joint is fully assembled in aligned condition, pull the spigot outwards to maximum and set the angular deflection according to the requirement.

5. **Disassembly:** Ensure the assembly to be in aligned condition before disassembly. After aligned condition push the pipe into the socket along its axis until it is in abutment and remove the lock segments through the opening in the socket face. Remove all lock segments one by one and joints shall be disassembled with the help of tools and tackles.

Advantages over existing Restrained Joint:

1. High pressure ratings can be achieved, thus making this product to be used for high pressure lines without thrust blocks constructions.
2. Low assembly time: - The new designed joint can be assembled in 20-30 minutes (for average DN 1000 size) whereas the conventional restrained joint take 120-180 minutes for the assembly, thus enhancing speed of pipeline laying.
3. Less number of assembly parts: - The newly designed joint assembly is having much less number of assembly parts. Thus making the assembly process more efficient and convenient.
4. The higher permissible angular deflection of the invented joint design reduces the number of fittings requirements for the same pipeline. The combination of invented positive lock system for restrained joint DI Pipes with same joint fittings make entire pipeline system highly flexible and convenient in design as well laying.
5. Wider Area of Application: - New joint has widen the scope of application of restrained DI pipes. Due to positive locking system in DI pipes, these pipes can be laid by dragging techniques, such as Horizontal Directional Drilling, Floating pipe

lines on through water bodies and laying pipes by dragging technique. Conventional restrained pipes or standard push on joint di pipes cannot be laid by these methods.

6. The invented product significantly reduces total cost of complete pipeline.

Areas of Application:-

1. Ductile iron pipe lines without thrust blocks.
2. High pressure applications.
3. Pipe lines on steep slopes.
4. Trenchless Ductile Iron pipe lines.
5. Bridge pipelines.
6. Snow making pipelines.
7. Firefighting mains.
8. Laying by horizontal directional drilling.
9. Floating Pipelines in marshy area / river or water bodies.

Although the invention has been described with reference to specific embodiments, this description is not meant to be construed in a limiting sense. Various modifications of the disclosed embodiments, as well as alternate embodiments of the invention, will become apparent to persons skilled in the art upon reference to the description of the invention. It is therefore contemplated that such modifications can be made without departing from the spirit or scope of the present invention as defined.

Revendications

1. Système de verrouillage positif pour des joints auto-retenus de tuyaux et de raccords en fonte ductile repoussée, comprenant :
- une douille (1) en forme de cloche et un embout à extrémité lisse (2) prévus sur des tuyaux en fonte ductile, de sorte que l'embout à extrémité lisse (2) soit enfoncé dans la douille (1) de tuyau pour permettre l'assemblage de deux tuyaux ;
 - un joint en élastomère/caoutchouc (5) placé dans une chambre à joint (7) prévue dans la douille (1) en forme de cloche ;
 - un cordon de soudure (4) prévu sur la périphérie circonférentielle de l'extrémité lisse (2) du tuyau ;
 - une série de segments de verrouillage (3) insérés à travers la fenêtre découpée (8) et entraînés en rotation entre le cordon de soudure (4) et la surface (9) interne de la chambre circonférentielle (6) ;
 - une chambre (12) est prévue pour avoir un jeu de l'extrémité lisse (2) du tuyau et de la chambre (11) avec la paroi interne de la douille (1) ;
- dans lequel le diamètre interne du joint (5) est inférieur au diamètre externe de l'extrémité lisse (2) pour permettre à l'extrémité lisse (2) du tuyau de comprimer le joint (5) radialement pour rendre la jointure étanche à l'eau ;
- dans lequel la douille (1) en forme de cloche est en outre munie d'une bague (10) agissant comme un obturateur mécanique afin de limiter la déviation angulaire au maximum autorisé et fonctionnant comme une caractéristique de sécurité de conception à des pressions de fluide plus élevées ;
- dans lequel le segment de verrouillage (3) a une face avant (15) à un angle approprié pour dissiper toutes les forces axiales dans la direction requise et une face (14) arrière circulaire/sphérique correspondant à la face (9) de la chambre de douille pour un glissement doux lors de la déviation angulaire axiale au niveau de la jointure ;
- dans lequel le rayon et le centre de la face (9) et (14) circonférentielle sont calculés de telle sorte que les forces axiales maximales puissent être transférées à la douille (1) de tuyau à la déviation angulaire requise de deux axes ; et
- dans lequel les efforts de poussée générés par la pression du fluide transmetteur sont transférés du cordon de soudure (4) au segment de verrouillage (3) et du segment de verrouillage (3) à la chambre circonférentielle (6) de la douille (1).

2. Système de verrouillage selon la revendication 1, dans lequel le segment de verrouillage (3) est toujours à la périphérie externe de l'extrémité lisse (2) du tuyau.
- 5 3. Système de verrouillage selon la revendication 1, dans lequel le rayon de la face inférieure (16) du segment de verrouillage (3) est inférieur ou égal aux limites requises par rapport au rayon extérieur de la périphérie de l'extrémité lisse (2).
- 10 4. Système de verrouillage selon la revendication 1, dans lequel les deux faces (14) et (9) ont les mêmes rayons pour permettre un meilleur ajustement et un glissement doux lors de la déviation axiale de la jointure et de la transmission de la charge.
- 15 5. Système de verrouillage selon la revendication 1, dans lequel le jeu (6A) est prévu entre la face avant (15) du segment de verrouillage (3) et la face d'extrémité de la chambre (6) pour faciliter la déviation angulaire de la jointure.
- 20 6. Système de verrouillage selon la revendication 1, dans lequel la hauteur du bloc en saillie et de la face (14) du segment de verrouillage (3) est calculée de manière à ce qu'elle soit suffisante pour transmettre les charges dans une direction requise et à une intensité minimale.
- 25 7. Système de verrouillage selon la revendication 1, dans lequel une série de segments de verrouillage (3) demeurent sur la périphérie externe de l'extrémité lisse (2) du tuyau à l'aide d'une courroie de liage (18).
- 30 8. Système de verrouillage selon la revendication 1, dans lequel les segments de verrouillage (3) sont munis de butées d'extrémité (17) faisant saillie vers l'extérieur pour donner un logement à la courroie de liage (18) et faciliter la rotation de verrouillage pendant l'assemblage.
9. Système de verrouillage selon la revendication 1, dans lequel l'extrémité lisse (2) et la douille (1) en forme de cloche sont en fonte ductile.

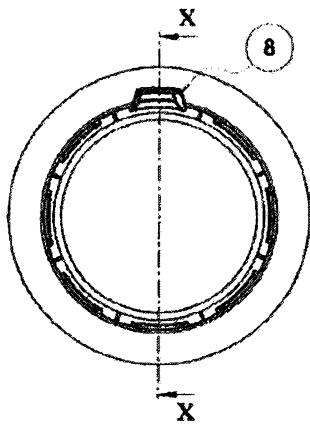

FIG-2

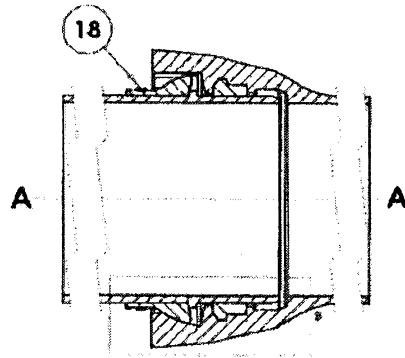

FIG-1
SECTION X-X

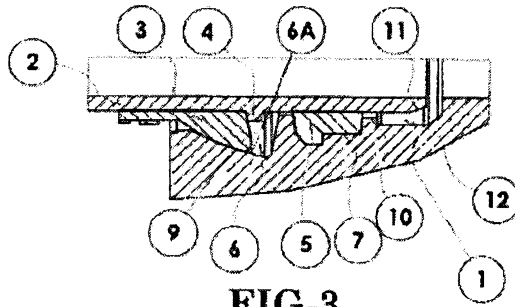

FIG-3

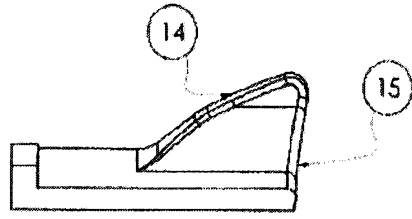

FIG-4

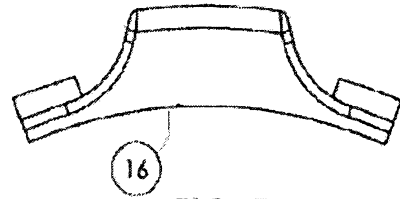

FIG-5

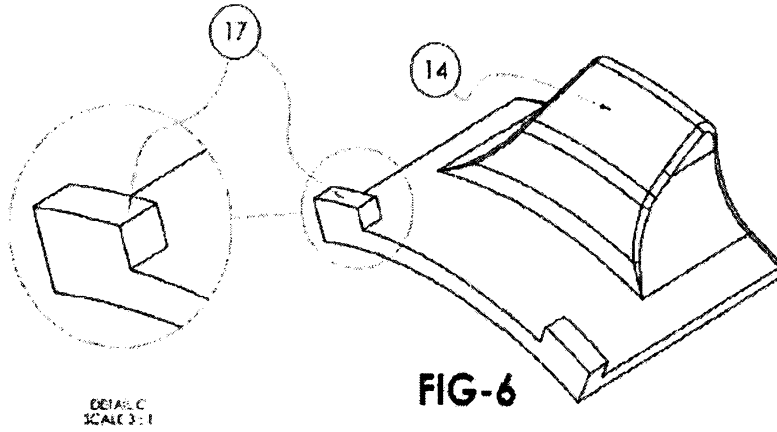

FIG-6

DETAIL C
SCALE 3:1

ABSTRACT**Positive Lock system for Restrained Joints of Ductile Iron Spun Pipes and Fittings**

This present invention relates to novel positive lock system for restrained joints of ductile iron spun pipes and fittings which are able to take all the thrust loads produced due to transmitting fluids pressure and provide certain angular deflections to the axis of two pipes. For ductile iron pipe to be joined, a socket (bell shape) and a spigot (plain end) sections are provided in pipes. For joining plain end is inserted in bell shape end. As the water pressure surges, the joint tends to disengage due to increasing axial loads. To take these axial loads, a circumferential chamber is provided in bell shape end and plain end is provided with a weld bead of suitable size. Axial forces generated due to water pressure is transmitted to pipe socket through welding via locking segments. Locking segments are inserted in circumferential chamber and they stays between chamber and welding bead. Circumferential chamber has suitable clearances to provide the required angular deviations at the joint.

Refer to figure 3

PATENT COOPERATION TREATY

PCT

INTERNATIONAL SEARCH REPORT

(PCT Article 18 and Rules 43 and 44)

Applicant's or agent's file reference 25063-P1PCT	FOR FURTHER ACTION	see Form PCT/ISA/220 as well as, where applicable, item 5 below.
International application No. PCT/IB2018/051843	International filing date (day/month/year) 20-03-2018	(Earliest) Priority Date (day/month/year) 21-03-2017
Applicant JINDAL SAW LTD		

This international search report has been prepared by this International Searching Authority and is transmitted to the applicant according to Article 18. A copy is being transmitted to the International Bureau.

This international search report consists of a total of 3 sheets.

It is also accompanied by a copy of each prior art document cited in this report.

1. Basis of the report

a. With regard to the **language**, the international search was carried out on the basis of:

- the international application in the language in which it was filed.
- a translation of the international application into _____ which is the language of a translation furnished for the purposes of international search (Rules 12.3(a) and 23.1(b)).

b. This international search report has been established taking into account the **rectification of an obvious mistake** authorized by or notified to this Authority under Rule 91 (Rule 43.6bis(a)).

c. With regard to any **nucleotide and/or amino acid sequence** disclosed in the international application, see Box No. I.

2. **Certain claims were found unsearchable** (see Box No. II).

3. **Unity of invention is lacking** (see Box No. III).

4. With regard to the **title**,

- the text is approved as submitted by the applicant.
- the text has been established by this Authority to read as follows:

5. With regard to the **abstract**,

- the text is approved as submitted by the applicant.
- the text has been established, according to Rule 38.2, by this Authority as it appears in Box No. IV. The applicant may, within one month from the date of mailing of this international search report, submit comments to this Authority.

6. With regard to the **drawings**,

a. the figure of the **drawings** to be published with the abstract is Figure No. 3

- as suggested by the applicant.
- as selected by this Authority, because the applicant failed to suggest a figure.
- as selected by this Authority, because this figure better characterizes the invention.

b. none of the figures is to be published with the abstract.

INTERNATIONAL SEARCH REPORT

International application No.

PCT/IB2018/051843

A. CLASSIFICATION OF SUBJECT MATTER
F16L17/00,F16L37/00 Version=2018.01

According to International Patent Classification (IPC) or to both national classification and IPC

B. FIELDS SEARCHED

Minimum documentation searched (classification system followed by classification symbols)

F16L

Documentation searched other than minimum documentation to the extent that such documents are included in the fields searched

Electronic data base consulted during the international search (name of data base and, where practicable, search terms used)

TotalPatent One, IPO Internal Database, Google Patents (LOCK, PIPE, LOCKING SEGMENT, TYING BELT, END SUPPORT, CLEARANCE, GASKET, RING, WELD
BRAD)

C. DOCUMENTS CONSIDERED TO BE RELEVANT

Category*	Citation of document, with indication, where appropriate, of the relevant passages	Relevant to claim No.
X	OA4282 A (SOCIETE BDITE: PONT-A-MOUSSON S.A.) 31 DECEMBER 1979 (31.12.1979) Abstract; Page-2-Line-2-6; Page 8-Line 25-27; Page 12-Line-6-10 ;Figure 1-18	1, 2, 3, 5
Y	Abstract; Page-2-Line-2-6; Page 8-Line 25-27; Page 12-Line-6-10 ;Figure 1-18	7, 8, 9
A	Abstract; Page-2-Line-2-6; Page 8-Line 25-27; Page 12-Line-6-10 ;Figure 1-18	4, 6
Y	EP0455490 B1 (AMSTED INDUSTRIES INC) 27 SEPTEMBER 1995 (27.09.1995) Abstract; Column-4-Line 13-21; Figure 1; Claim 1, 6	7, 8, 9

Further documents are listed in the continuation of Box C.

See patent family annex.

* Special categories of cited documents:

"A" document defining the general state of the art which is not considered to be of particular relevance

"E" earlier application or patent but published on or after the international filing date

"L" document which may throw doubts on priority claim(s) or which is cited to establish the publication date of another citation or other special reason (as specified)

"O" document referring to an oral disclosure, use, exhibition or other means

"P" document published prior to the international filing date but later than the priority date claimed

"I" later document published after the international filing date or priority date and not in conflict with the application but cited to understand the principle or theory underlying the invention

"X" document of particular relevance: the claimed invention cannot be considered novel or cannot be considered to involve an inventive step when the document is taken alone

"Y" document of particular relevance: the claimed invention cannot be considered to involve an inventive step when the document is combined with one or more other such documents, such combination being obvious to a person skilled in the art

"&" document member of the same patent family

Date of the actual completion of the international search

06-07-2018

Date of mailing of the international search report

06-07-2018

Name and mailing address of the ISA/

Indian Patent Office
Plot No.32, Sector 14, Dwarka, New Delhi-110075
Facsimile No.

Authorized officer

Anurag Singh

Telephone No. +91-1125300200

INTERNATIONAL SEARCH REPORT

Information on patent family members

International application No.

PCT/IB2018/051843

Citation	Pub.Date	Family	Pub.Date
EP 455490 B1	27-09-1995	CA 2036785 C	13-08-1996
		DE 69113315 T2	07-03-1996
		JP 06089868 B2	14-11-1994
		BR PI9101747 A	10-12-1991

PATENT COOPERATION TREATY

From the
INTERNATIONAL SEARCHING AUTHORITY

To:
GARG, VIDISHA
ANAND AND ANAND ADVOCATES, B-41,
NIZAMUDDIN EAST, NEW DELHI-110013
INDIA

PCT

WRITTEN OPINION OF THE
INTERNATIONAL SEARCHING AUTHORITY

(PCT Rule 43bis.1)

Date of mailing (day/month/year) 06-07-2018
--

Applicant's or agent's file reference 25063-P1PCT	FOR FURTHER ACTION See paragraph 2 below
--	--

International application No. PCT/IB2018/051843	International filing date (day/month/year) 20-03-2018	Priority date (day/month/year) 21-03-2017
--	--	--

International Patent Classification (IPC) or both national classification and IPC
F16L17/00, F16L37/00 Version=2018.01

Applicant
JINDAL SAW LTD

1. This opinion contains indications relating to the following items:

- Box No. I Basis of the opinion
- Box No. II Priority
- Box No. III Non-establishment of opinion with regard to novelty, inventive step and industrial applicability
- Box No. IV Lack of unity of invention
- Box No. V Reasoned statement under Rule 43bis.1(a)(i) with regard to novelty, inventive step and industrial applicability; citations and explanations supporting such statement
- Box No. VI Certain documents cited
- Box No. VII Certain defects in the international application
- Box No. VIII Certain observations on the international application

2. **FURTHER ACTION**

If a demand for international preliminary examination is made, this opinion will be considered to be a written opinion of the International Preliminary Examining Authority ("IPEA") except that this does not apply where the applicant chooses an Authority other than this one to be the IPEA and the chosen IPEA has notified the International Bureau under Rule 66.1bis(b) that written opinions of this International Searching Authority will not be so considered.

If this opinion is, as provided above, considered to be a written opinion of the IPEA, the applicant is invited to submit to the IPEA a written reply together, where appropriate, with amendments, before the expiration of 3 months from the date of mailing of Form PCT/ISA/220 or before the expiration of 22 months from the priority date, whichever expires later.

For further options, see Form PCT/ISA/220.

Name and mailing address of the ISA/ Indian Patent Office Plot No. 32, Sector 14, Dwarka, New Delhi-110075 Facsimile No.	Date of completion of this opinion 06-07-2018	Authorized officer Anurag Singh Telephone No. +91-1125300200
--	--	--

WRITTEN OPINION OF THE
INTERNATIONAL SEARCHING AUTHORITY

International application No.
PCT/IB2018/051843

Box No. I Basis of this opinion

1. With regard to the **language**, this opinion has been established on the basis of:
 - the international application in the language in which it was filed.
 - a translation of the international application into _____ which is the language of a translation furnished for the purposes of international search (Rules 12.3(a) and 23.1(b)).
2. This opinion has been established taking into account the **rectification of an obvious mistake** authorized by or notified to this Authority under Rule 91 (Rule 43bis.1(a)).
3. With regard to any **nucleotide and/or amino acid sequence** disclosed in the international application, this opinion has been established on the basis of a sequence listing:
 - a. forming part of the international application as filed:
 - in the form of an Annex C/ST.25 text file.
 - on paper or in the form of an image file.
 - b. furnished together with the international application under PCT Rule 13ter.1(a) for the purposes of international search only in the form of an Annex C/ST.25 text file.
 - c. furnished subsequent to the international filing date for the purposes of international search only:
 - in the form of an Annex C/ST.25 text file (Rule 13ter.1(a)).
 - on paper or in the form of an image file (Rule 13ter.1(b) and Administrative Instructions, Section 713).
4. In addition, in the case that more than one version or copy of a sequence listing has been filed or furnished, the required statements that the information in the subsequent or additional copies is identical to that forming part of the application as filed or does not go beyond the application as filed, as appropriate, were furnished.
5. Additional comments:

WRITTEN OPINION OF THE
INTERNATIONAL SEARCHING AUTHORITY

International application No.
PCT/IB2018/051843

Box No. V Reasoned statement under Rule 43bis.1(a)(i) with regard to novelty, inventive step and industrial applicability; citations and explanations supporting such statement

I. Statement

Novelty (N)	Claims	<u>4, 5, 6, 7, 8, 9</u>	YES
	Claims	<u>1, 2, 3</u>	NO
Inventive step (IS)	Claims	<u>4, 6</u>	YES
	Claims	<u>1, 2, 3, 5, 7, 8, 9</u>	NO
Industrial applicability (IA)	Claims	<u>1-9</u>	YES
	Claims	<u>NONE</u>	NO

2. Citations and explanations:

D1: OA4282 A (SOCIETE BDITE: PONT-A-MOUSSON S.A.) 31 DECEMBER 1979
(31.12.1979)

D2: EP0455490 B1 (AMSTED INDUSTRIES INC) 27 SEPTEMBER 1995
(27.09.1995)

Novelty under PCT Article 33(2)

D1 disclose a pipe coupling, a counter flange (8) is locked in position on a socket (3) before a spigot (1) is pushed finally home into the socket. A stop ring (31, 32) secures the spigot against withdrawal. When the stop ring is a rigid ring on a split ring, the spigot may be kept separate from the parts, until the latter has been locked in position. When the stop ring is not self-supporting, the tip of the spigot lies within the parts while part is being locked in position. Thereafter the spigot is pushed home into the socket (Abstract; Figure 1-18). D1 also disclose that there are a series of segments, provided with a toothing (26) saw tooth oriented opposite to the direction of the movement that can execute the male end under internal pressure. In the case where the stop ring segments with gear, the segments can be permanently attached to the stop ring or be movable in said ring (Page 12-Line-6-10) and in addition to this stopper ring is nested the companion flange, and can be secured on the socket of the other pipe by one of the means. D1 also disclose that the spigot is supported against the stop ring; itself stops against the companion flange. It should be noted that, since the snap ring (5) is slotted and resiliently expandable and retractable, this ring squeezes onto the spigot and thus relieves the weld bead (2) of support forces and shear (Page 8-Line 25-27). D1 also disclose that the gasket formed thereby - is rigid and does not allow angular displacement between the longitudinal axes; of the two connected tubes; further, for high pressures in service, there is risk of damage to the cutting edges. Another known device for

Supplemental Box

In case the space in any of the preceding boxes is not sufficient.

Continuation of:

Continuation of Citation and Explanation(Box5)

locking the seal includes grooves cut into the spigot and in which can find a retaining ring, which is supported on a counter-ring secured in the nest (Page-2-Line-2-6).

With respect to claim 1, D1 disclose a lock system for joining the pipes and the joining is in between the socket and the spigot wherein the spigot is pushed into the socket for joining the two pipes and gasket and weld bead are also there and provided on the socket and pipe respectively and a series of lock segments with the configuration of the tooth shape is also there and the shape of the lock segment is same as disclosed in present invention. The socket is also provided with the ring in order to limit the angular displacement between the longitudinal axis and the transfer of the load will also be from weld bead to the lock segment and from lock segment to the circumferential chamber of the socket.

With regard to claim 2, D1 disclose that the segments or the locking segments of toothed shape are provided on the outer side of the surface of the pipe.

With regard to claim 3, Figure 17 of D1 disclose that the inner radius of the lock toothed segment limits is in between the outer radius limits of the pipe and from common general knowledge it is inherent that the limit of radius of locking segment and that of the outer radius of the pipe should be in limits.

Thus the subject matter of claims 1, 2, 3 fails to meet the requirements of PCT Article 33(2) as it does not involve novelty in view of disclosure of document d1 of particular relevance when taken alone.

With regard to claims 4-9, D1 is not disclosing their technical features i.e. tying belt, end supports, height calculation for the locking segment and protruding block. Thus subject matter of claims 4-9 is novel and fulfills the requirements of PCT Article 33(2).

INVENTIVE STEP under Article 33(3)

The subject matter of claims 1-3 fails to meet the requirements of PCT Article 33(3) as it does not involve inventive step in view of disclosure of documents D1 when taken alone.

D2 disclose pipe joint for joining the spigot end (12) of a first ductile iron pipe to the socket end (10) of a second ductile iron pipe, said pipe joint comprising: a retainer ring (34) having locking means (38, 94) for engaging the spigot end (12) of the first pipe; a restraining ring (34) coupled to the socket end of the second pipe and extending around the spigot end (12) of the first pipe in use, the restraining ring being arranged to be movable in the axial direction of said joint relative to the retainer ring and having an inclined surface for cooperating with said retainer ring; and urging means (31, 44, 93, 98) for urging said locking means into engagement with said spigot end of the first pipe (Abstract; Figure 1; Claim 1). D2 also disclose that the first pipe, comprises a groove ring having a plurality of locking segments each of said locking segments having protruding teeth (40) and said groove ring (36) also has a top surface which engages the inclined inner surface of said circular restraining ring (claim 6). D2 disclose that upon tightening of threaded bolt (44) against front face of circular restraining ring, the outer or top surface of locking segment groove ring contacts the inclined inner surface of circular restraining ring. Top surface is usually convex. This action forces teeth of locking segment against and into a secure abutment with outer surface of spigot end of the first pipe (Column-4-Line 13-21).

With regard to claim 5, D1 discloses a clearance between the front face of the lock segment and chamber and this feature is inherent from common general knowledge.

With regard to claim 7, 8, D2 disclose a restraining ring which is obvious that it is a tying belt supporting the locking segment and these lock segments are also remain on the outer periphery of the plain end with the help of the belt or the restraining means and in addition to this the end stoppers or the bolts are also attached with the restraining means or the tying belt.

With regard to claim 9, both D1 and D2 discloses a coupling between the pipes and it is also obvious to a person skill in the art that the material can be any material to perform the joint between the pipes and the same claim is not disclosing technical feature of the present invention.

Thus the subject matter of claims 5, 7-9 fails to meet the requirements of PCT Article 33(3) as it does not involve inventive step in view of disclosure of documents D1 and D2.

However Claims 4,6 disclose the radii to be same for the sliding surface of the locking segment and that of the sprocket surface and the calculation of the height of the protruding block and that of the lock segment and D1-D2 defines only the general state of the

WRITTEN OPINION OF THE INTERNATIONAL SEARCHING AUTHORITY

art about the pipe connection with respect to claims 4, 6 which is not considered to be of particular relevance and thus the subject matter of claims 4, 6 meets the requirements of PCT Article 33(2), 33(3) and involves both novelty and inventive step in view of disclosure of documents D1-D2.

Industrial Applicability under PCT Article 33(4)

The subject matter of claims 1-9 is considered to be industrially applicable and meets the requirements of Article 33(4) PCT.