

Feb. 2, 1960

G. H. RODGERS

2,923,091

SPINNING WHEEL MUSIC TOY

Filed June 24, 1958

FIG. 1.

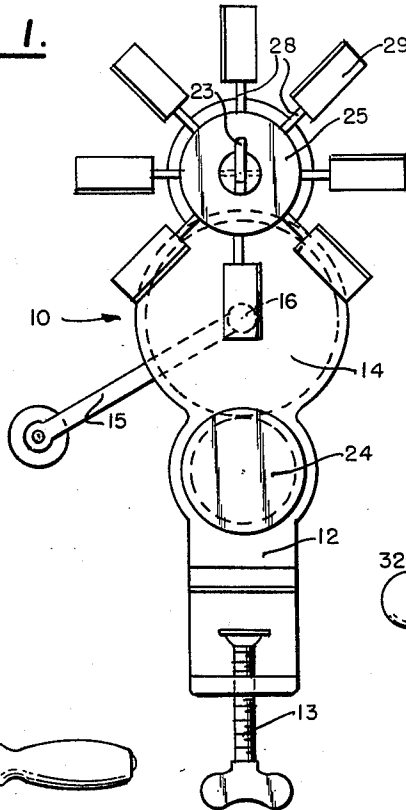

FIG. 2.

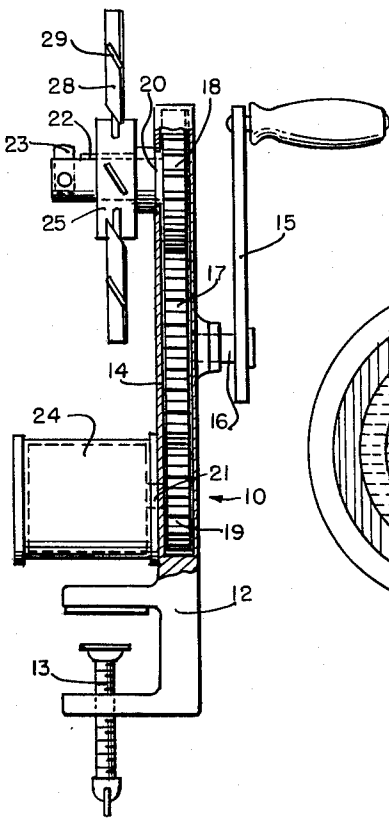

FIG. 3.

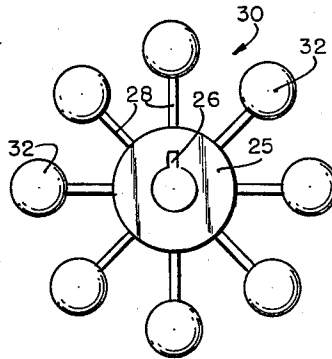

FIG. 4.

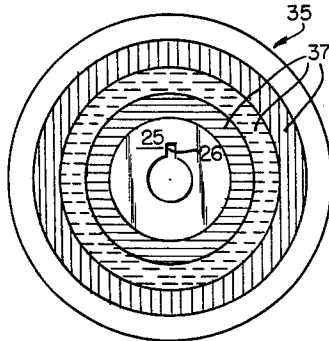
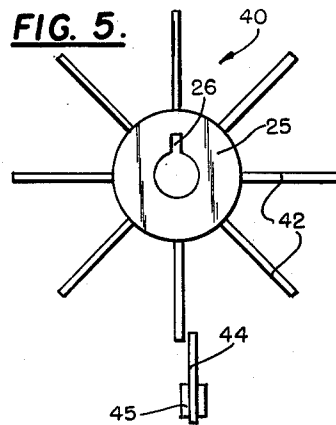

FIG. 5.



INVENTOR

Georgia H. Rodgers

1

2,923,091

SPINNING WHEEL MUSIC TOY

Georgia H. Rodgers, Corning, Calif.

Application June 24, 1958, Serial No. 744,171

5 Claims. (Cl. 46—175)

This invention relates to amusement devices and more particularly to a toy for children.

It is an object of the present invention to provide an animated and audible toy for children that will produce both an entertaining audible effect and an animated visible effect that is amusing, fascinating, and colorful.

Another object of the present invention is to provide a spinning wheel music toy of the above type that is completely manually operated from a single drive means to simultaneously actuate both the audible and visible elements thereof.

Other objects of the invention are to provide a spinning wheel music toy bearing the above objects in mind which is of simple construction, has a minimum number of parts, is inexpensive to manufacture and efficient in operation.

For other objects and for a better understanding of the invention, reference may be had to the following detailed description taken in conjunction with the accompanying drawing, in which:

Figure 1 is a front elevational view of a spinning wheel music toy made in accordance with the present invention;

Figure 2 is a side elevational view of the device shown in Figure 1, with parts broken away;

Figure 3 is a front elevational view of a modified form of visible spinning element;

Figure 4 is a view similar to Figure 3, showing a still further modified visible spinning element; and

Figure 5 is a fragmentary front elevational view of a still further modified form of spinning element made in accordance with the present invention.

Referring now more in detail to the drawing, and more particularly to Figures 1 and 2 thereof, an amusement device 10 made in accordance with the present invention is shown to include a frame 12 having a clamp screw 13 supported at the lower end for attaching the device to any support. The frame 12 includes a housing 14 through which a transverse shaft 16 extends that rotatably supports a drive gear 17 within the housing. A handle 15 is secured to the outer end of the shaft 16 for effecting rotation of the drive gear 17 which is in meshing engagement with an upper driven pinion 18 and a lower driven pinion 19. The lower pinion 19 is secured to a lower transverse shaft 21 that is in driving engagement with a music box 24 secured to the outside of the housing. The upper drive pinion 18 is secured to an upper transverse shaft 20 that has a radially outwardly extending key 22 and a pivotable stop element 23. The upper shaft 20 and key 22 are slidably received within the central bore and keyway 26 of a hub 25 that is releasably secured thereon by means of the stop 23 which is pivotable out of blocking engagement in the path of movement of the hub 25 whenever it is desired to remove or mount the hub relative thereto.

In all embodiments of the present invention, the hub 25 forms a base of the spinning wheel. In the embodiments illustrated in Figures 1 and 2, a plurality of radially outwardly extending rigid rods 28 are attached at their inner ends to the hub 25, while multi-color cards 29 are secured to the outer free ends thereof. As a result, upon rotation of the handle 15, the colored cards 29 will be rotated at a high speed by the aforementioned gears 17, 18, and the music box 24 will be driven by the lower pinion 19. In

2

the embodiment illustrated in Figure 3 of the drawing, the operation is substantially the same except that multi-color balls 32 are secured to the outer ends of the rigid rods 28 in place of the cards 29, whereby the resulting spinner 30 will produce a slightly different visible effect when rotated.

In Figure 4 of the drawing, a further modified form of construction is shown wherein a disc 35 is carried by the hub 25 and has a plurality of different colored bands 37 which tend to blend with each other as the device is operated. If desired, a spiral band having a plurality of different colors may be used instead of the concentric band relationship illustrated in Figure 4 to produce a still different visible effect.

In Figure 5 of the drawing, a still further modified form of construction 40 is shown wherein the hub 25 supports a plurality of radially outwardly extending flexible rods 42 that sequentially engage with a rigid stop 44 secured to a mounting 45. This stop 44 is disposed in the path of rotation of the flexible rods 42 which may also be of different colors, so as to produce a still further visible and audible effect. If desired, the rods 42 may be rigid and the stop 44 may be flexible to produce slightly different, but substantially similar results. The mounting 45 may be secured to the housing 14 intermediate the shaft 20 and the music box 24.

While various changes may be made in the detail construction, it shall be understood that such changes shall be within the spirit and scope of the present invention as defined by the appended claims.

What I claim as new and desire to protect by Letters Patent of the United States is:

1. An amusement device comprising a main frame, releasable means for securing said main frame to a support, an audible sounding device secured to one end of said main frame, a visible associated device secured to an opposite end of said main frame, said visible associated device including a shaft rotatably supported upon the main frame, said visible associated device having a hub supported upon said shaft for rotation therewith, said audible sounding device and said hub shaft respectively having pinion gears thereon, a large drive gear rotatably supported upon said main frame in driving engagement with said pinion gears of said audible sounding device and said hub shaft and a handle carried by said drive gear for effecting rotation thereof.

2. The combination as defined in claim 1, and said shaft having releasable means thereon for retaining said visible associated device upon said shaft whereby said visible associated device may be easily removed for replacement by another such device.

3. The combination according to claim 2, wherein said visible associated device has a plurality of radially outwardly extending rigid rods on said hub, and a plurality of multi-colored markers secured to the outer ends of said rods.

4. The combination according to claim 2, wherein said visible associated device has a disc extending from the hub, and a plurality of concentric multi-colored bands carried by said disc.

5. The combination according to claim 2, wherein said visible associated device has a plurality of radially outwardly extending flexible elements on said hub, and a fixed element carried by said fame in the path of movement of said flexible elements for engagement therewith.

References Cited in the file of this patent

UNITED STATES PATENTS

| | | | |
|----|-----------|---------|---------------|
| 70 | 1,175,372 | Newcomb | Mar. 14, 1916 |
| | 1,522,472 | Sundell | Jan. 6, 1925 |
| | 1,821,184 | Langos | Sept. 1, 1931 |